

A340E (2JZ-GE) AUTOMATIC TRANSMISSION

OPERATION

FUNCTION OF COMPONENTS

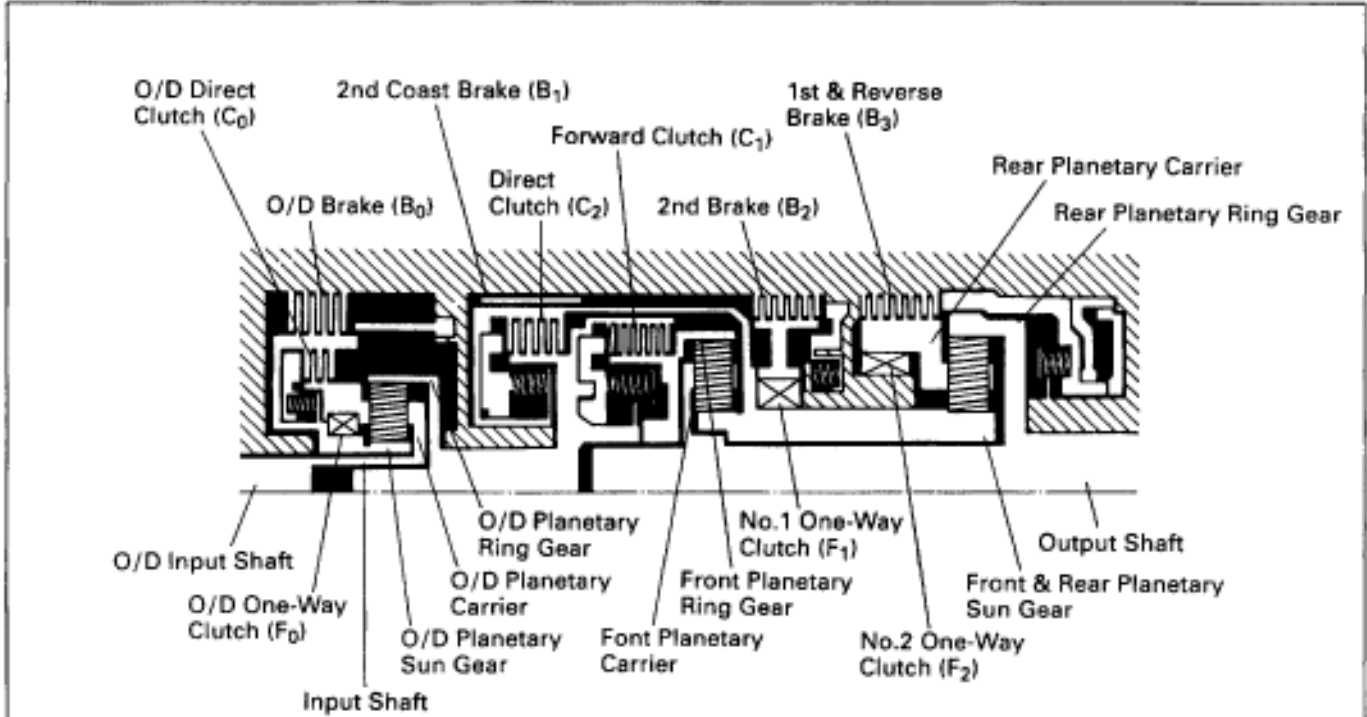

AT2157

○ Operating

Shift lever position	Gear position	C ₀	C ₁	C ₂	B ₀	B ₁	B ₂	B ₃	F ₀	F ₁	F ₂
P	Parking	○									
R	Reverse	○		○				○	○		
N	Neutral	○									
D	1st	○	○						○		○
	2nd	○	○				○		○	○	
	3rd	○	○	○			○		○		
	O/D		○	○	○		○				
2	1st	○	○						○		○
	2nd	○	○			○	○		○	○	
	*3rd	○	○	○			○		○		
L	1st	○	○					○	○		○
	*2nd	○	○			○	○		○	○	

* Down-shift only-no up-shift

COMPONENT	FUNCTION
O/D Direct Clutch (C ₀)	Connects overdrive sun gear and overdrive carrier
O/D Brake (B ₀)	Prevents overdrive sun gear from turning either clockwise or counterclockwise
O/D One-Way Clutch (F ₀)	When transmission is being driven by engine, connects overdrive sun gear and overdrive carrier
Forward Clutch (C ₁)	Connects input shaft and front planetary ring gear
Direct Clutch (C ₂)	Connects input shaft and front & rear planetary sun gear
2nd Coast Brake (B ₁)	Prevents front & rear planetary sun gear from turning either clockwise or counterclockwise
2nd Brake (B ₂)	Prevents outer race of F ₁ from turning either clockwise or counterclockwise, thus preventing front & rear planetary sun gear from turning counterclockwise
1st & Reverse Brake (B ₃)	Prevents rear planetary carrier from turning either clockwise or counterclockwise
No. 1 One-Way Clutch (F ₁)	When B ₂ is operating, prevents front & rear planetary sun gear from turning counterclockwise
No. 2 One-Way Clutch (F ₂)	Prevents rear planetary carrier from turning counterclockwise

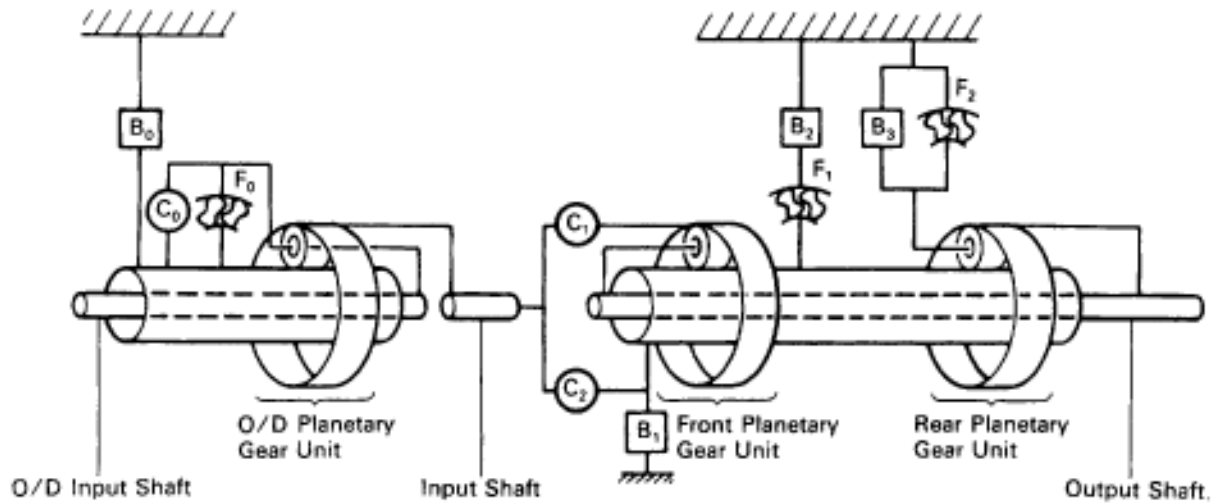

A78024

D or 2 Position 1st Gear

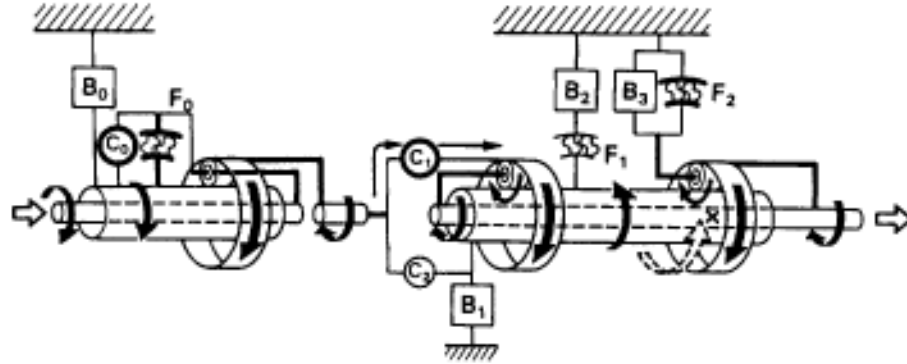

AT8675

D Position 2nd Gear

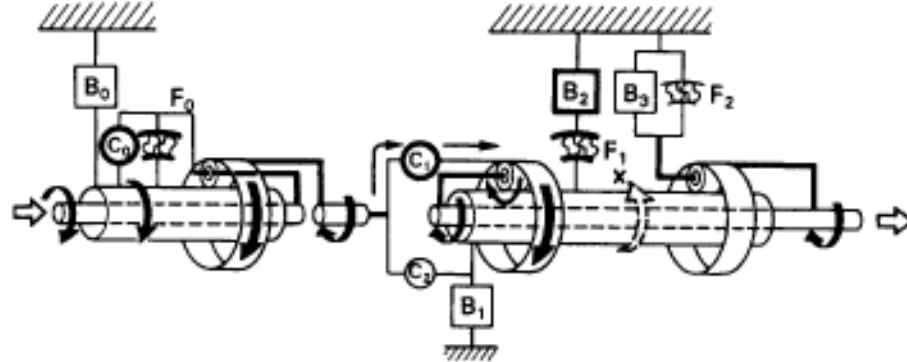

AT8676

D or 2 Position 3rd Gear

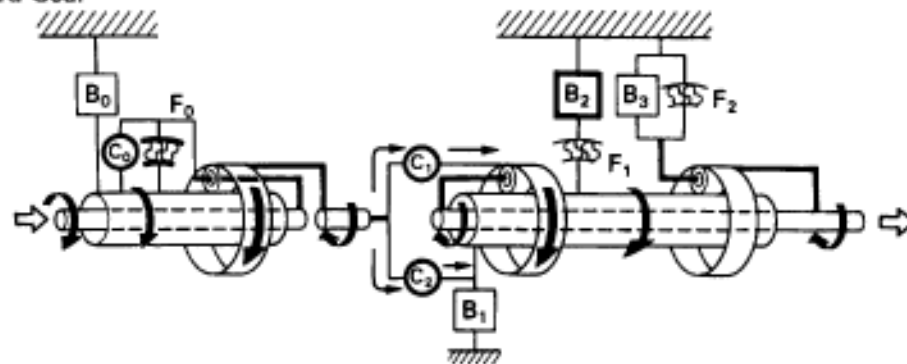

AT8677

D Position O/D

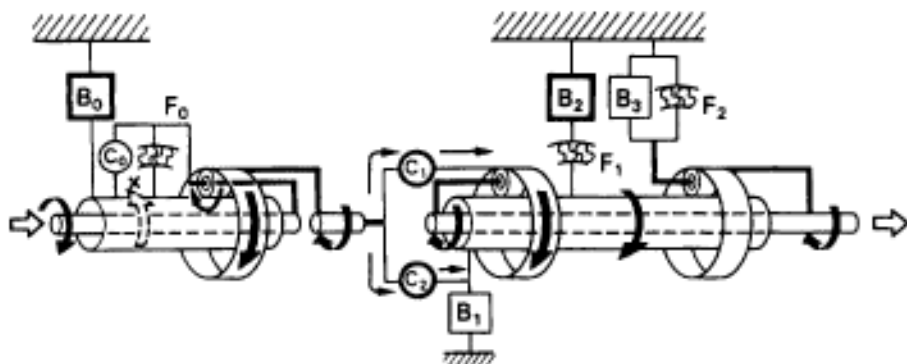

AT8678

2 or L Position 2nd Gear

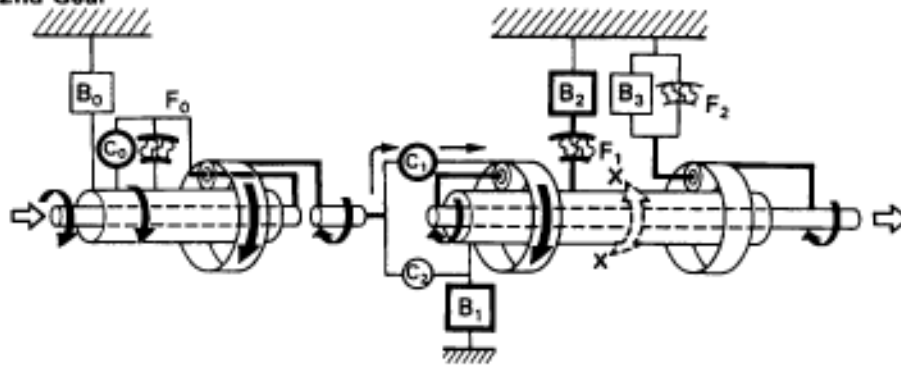

AT6679

L Position 1st Gear

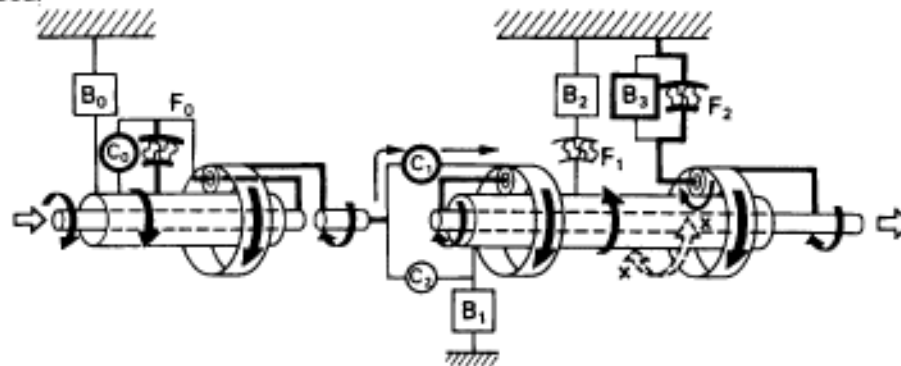

AT6680

R Position Reverse Gear

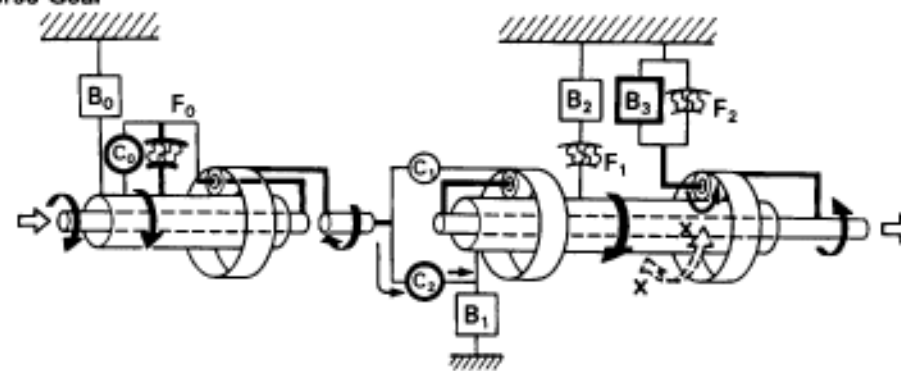

AT6681

HYDRAULIC CONTROL SYSTEM

The hydraulic control system is composed of the oil pump, the valve body, the solenoid valves and the clutches and brakes, as well as the fluid passages which connect all of these components. Based on the hydraulic pressure created by the oil pump, the hydraulic control system governs the hydraulic pressure acting on the torque converter clutch, clutches and brakes in accordance with the vehicle driving conditions.

There are three solenoid valves on the valve body. These solenoid valves are turned on and off by signals from the ECM to operate the shift valves. These shift valves then switch the fluid passages so that fluid goes to the torque converter clutch and planetary gear units.

Except for the solenoid valves, the hydraulic control system of the electronically controlled transmission is basically the same as that of the fully hydraulic controlled automatic transmission.

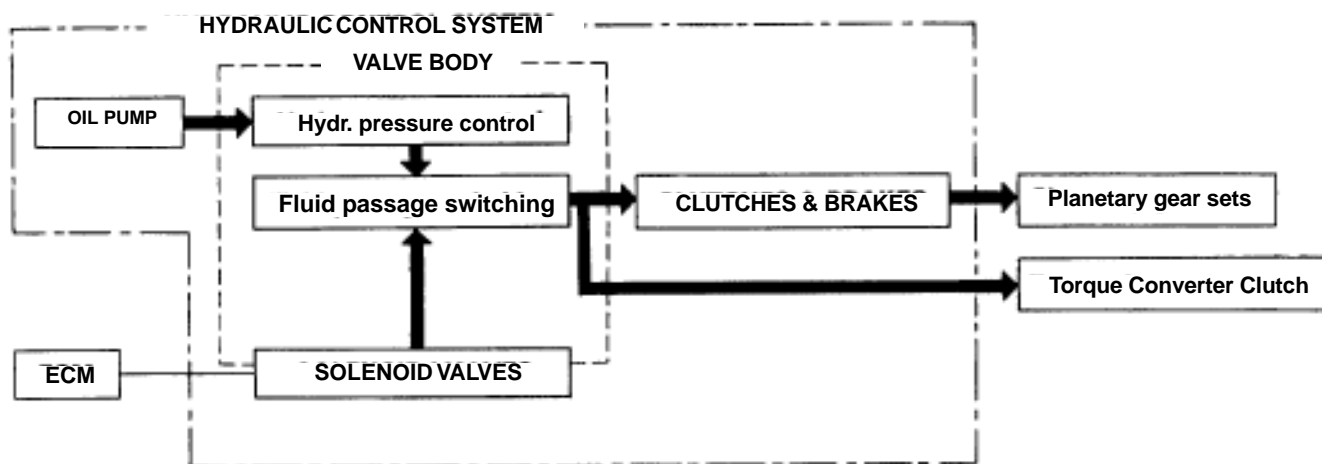

- **LINE PRESSURE**

Line pressure is the most basic and important pressure used in the automatic transmission, because it is used to operate all of the clutches and brakes in the transmission.

If the primary regulator valve does not operate correctly, line pressure will be either too high or too low. Line pressure that is too high will lead to shifting shock and consequent engine power loss due to the greater output required from the oil pump; line pressure that is too low will cause slippage of clutches and brakes, which will, in extreme cases, prevent the vehicle from moving. Therefore, if either of these problems are noted, the line pressure should be measured to see if it is within standard.

- **THROTTLE PRESSURE**

Throttle pressure is always kept in accordance with the opening angle of the engine throttle valve. This throttle pressure acts on the primary regulator valve and, accordingly, line pressure is regulated in response to the throttle valve opening.

In the fully hydraulic controlled automatic transmission, throttle pressure is used for regulating line pressure and as signal pressure for up-shift and down-shift of the transmission. In the electronically controlled transmission, however, throttle pressure is used only for regulating line pressure. Consequently, improper adjustment of the transmission throttle cable may result in a line pressure that is too high or too low. This, in turn, will lead to shifting shock or clutch and brake slippage.

ELECTRONIC CONTROL SYSTEM

The electronic control system, which controls the shift points and the operation of the lock-up clutch, is composed of the following three parts:

1. Sensors

These sensors sense the vehicle speed, throttle opening and other conditions and send this data to the ECM in the form of electrical signals.

2. ECM

The ECM determines the shift and lock-up timing based upon the signals from sensors, and controls the solenoid valves of the hydraulic control unit accordingly.

3. Actuators

These are three solenoid valves that control hydraulic pressure acting on the hydraulic valves to control shifting and lock-up timing.

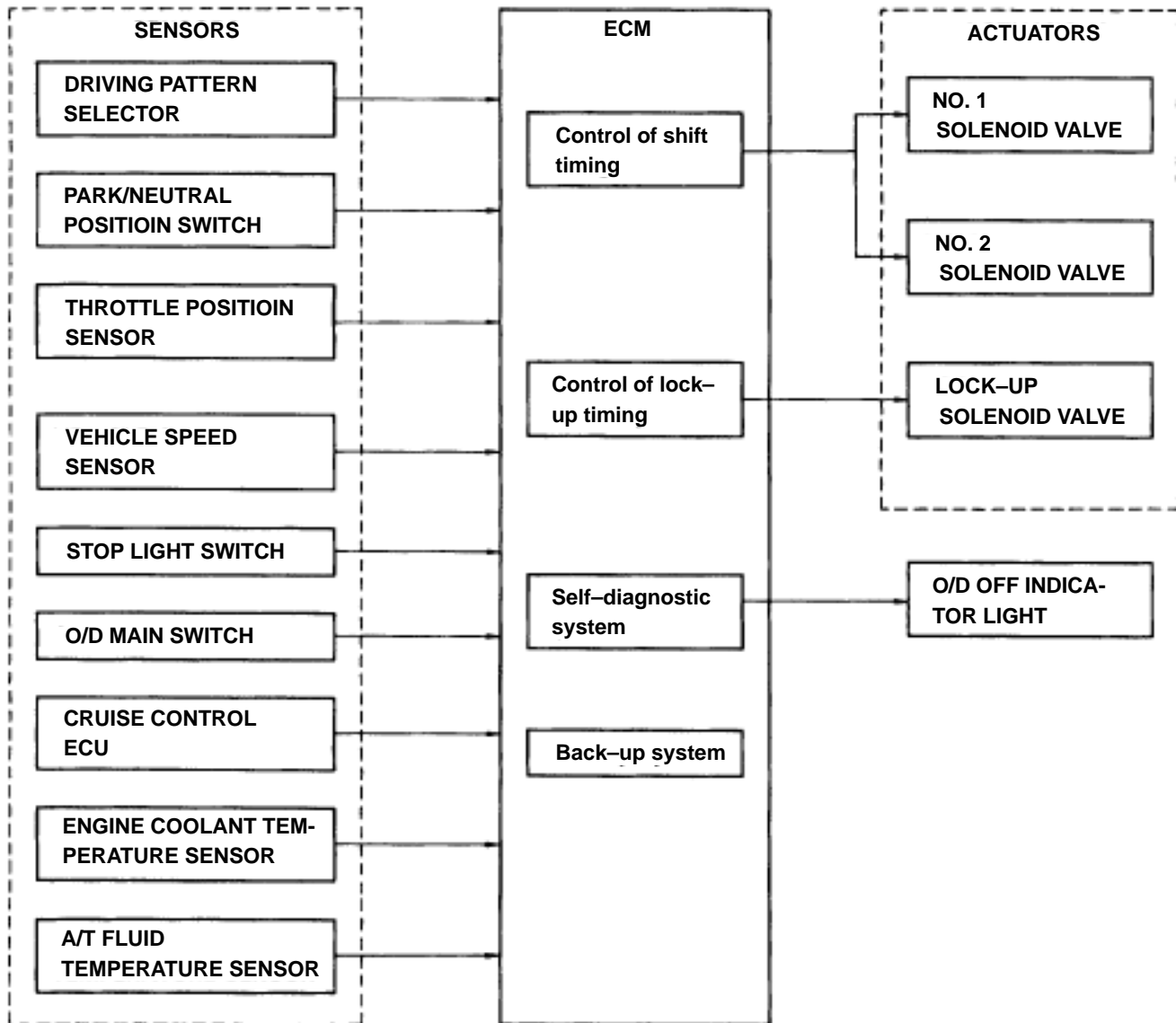

FUNCTION OF ECU

- **Control of Shifting Timing**

The ECM has programmed into its memory the optimum shift pattern for each shift lever position (D, 2, L position) and driving mode (Normal or Manual).

Based on the appropriate shift pattern, the ECM turns No.1 and No.2 solenoid valves on or off in accordance with the vehicle speed signal from the vehicle speed sensor and the throttle opening signal from the throttle position sensor. In this manner, the ECM operates each shift valve, opening or closing the fluid passages to the clutches and brakes to permit up-shift or down-shift of the transmission.

HINT: The electronic control system provides shift timing and lock-up control only while the vehicle is traveling forward. In REVERSE, PARK, and NEUTRAL, the transmission is mechanically, not electronically controlled.

- **Control of Overdrive**

Driving in overdrive is possible if the O/D main switch is on and the shift lever is in the D position. However, when the vehicle is being driven using the cruise control system (CCS), if the actual vehicle speed drops to about 4 km/h (2 mph) below the set speed while the vehicle is running in overdrive, the CCS ECU sends a signal to the ECM to release the overdrive and prevent the transmission from shifting back into overdrive until the actual vehicle speed reaches the speed set in the CCS memory.

On this model, if the engine coolant temperature falls below 60°C (140°F), the ECM sends a signal to the ECM, preventing the transmission from up-shifting into overdrive.

- **Control of Lock-Up System**

The ECM has programmed in its memory a lock-up clutch operation pattern for each driving mode (Normal or Manual). Based on this lock-up pattern, the ECM turns lock-up solenoid valve on or off in accordance with the vehicle speed signals received from the vehicle speed sensor and the throttle opening signals from the throttle position sensor.

Depending on whether lock-up solenoid valve is on or off, the lock-up relay valve performs changeover of the fluid passages for the converter pressure acting on the torque converter clutch to engage or disengage the lock-up clutch.

Mandatory Cancellation of Lock-Up System:

If any of the following conditions exist, the ECM turns off lock-up solenoid valve to disengage the lock-up clutch.

- 1) The brake light switch comes on (during braking).
- 2) The IDL points of the throttle position sensor close (throttle valve fully closed).
- 3) The vehicle speed drops 4 km/h (2 mph) or more below the set speed while the cruise control system is operating.
- 4) The engine coolant temperature falls below 60°C (140°F) and vehicle speed is under 60 km/h (37 mph), or 35°C (95°F) and vehicle speed is under 40 km/h (25 mph).

The purpose of 1) and 2) above is to prevent the engine from stalling if the rear wheels lock up.

The purpose of 3) is to cause the torque converter clutch to operate to obtain torque multiplication. The purpose of 4) is both to improve general driveability, and to speed up transmission warm-up.

Also, while the lock-up system is in operation, the ECM will temporarily turn it off during up-shift or down-shift in order to decrease shifting shock.

SYSTEM DIAGRAM

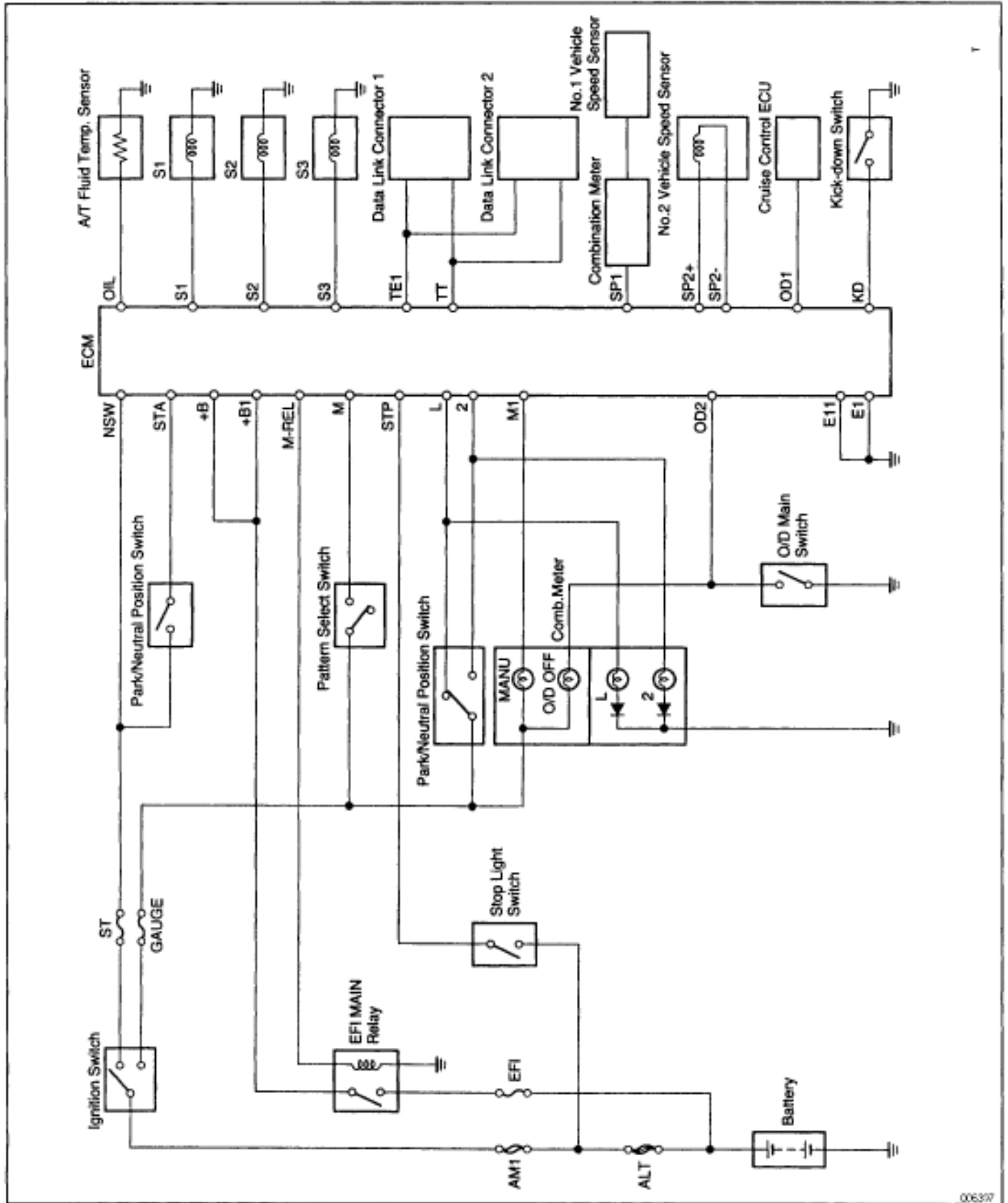

ARRANGEMENT OF COMPONENTS

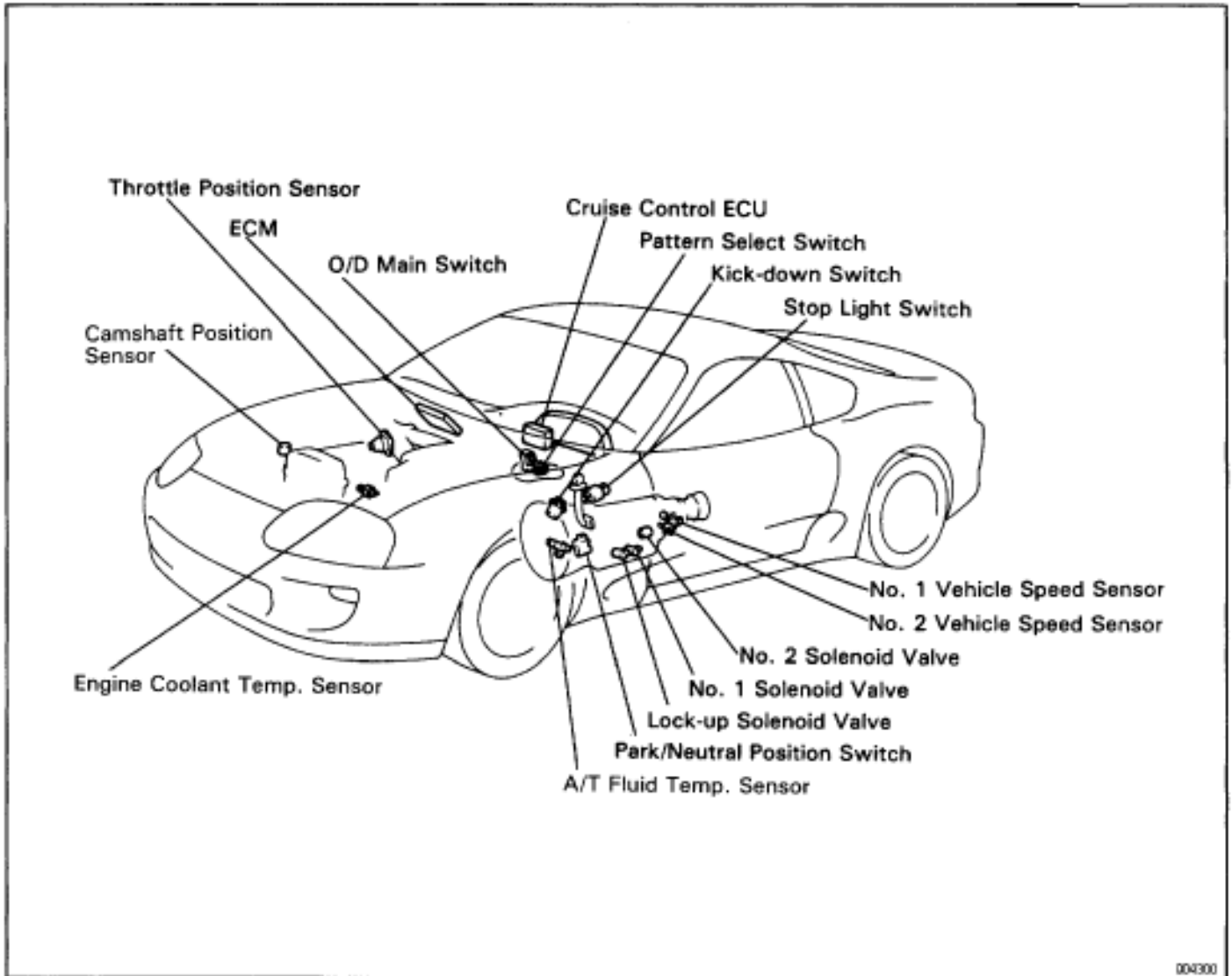

004300

No.	Components	Function
1	Pattern Select Switch	Selects the Manual mode or the Normal mode for shift and lock-up timing.
2	Crankshaft Position Sensor	Detects the engine speed.
3	Park/Neutral Position Switch	Detects the shift lever position.
4	Stop Light Switch	Detects if the brake pedal is depressed.
5	Throttle Position Sensor	Detects the throttle valve opening angle.
6	O/D Main Switch	Prevents up-shift to the O/D gear if the O/D main switch is off.
7	Cruise Control ECU	This ECU prevents the transmission from shifting into O/D and prohibits lock-up control when the vehicle's speed drops below the cruise control set speed parameter.

8	No.1 and No.2 Vehicle Speed Sensor	Detects the vehicle speed. Ordinarily, transmission control uses signals from the No.2 vehicle speed sensor, and the No.1 vehicle speed sensor is used as a back-up.
9	Engine Coolant Temp. Sensor	Detects the engine coolant temp.
10	ECM	Controls the engine and transmission actuators based on signals from each sensor.
11	No.1 and No.2 Solenoid Valves	Control the hydraulic pressure applied to each shift valve, and control the gear position and timing.
12	Lock-up Solenoid Valve (For lock-up control pressure modulation)	Controls the hydraulic pressure applied to the lock-up clutch and controls lock-up timing.
13	O/D OFF Indicator Light	Blinks and warns the driver, while the O/D main switch is pushed in, when the electronic control circuit is malfunctioning.
14	Kick-down Switch	Detects if the accelerator pedal is depressed beyond the full throttle valve opening position.
15	A/T Fluid Temp. Sensor	Detects the A/T fluid temp.

PRECAUTION

PRECAUTIONS









When working with FIPG material, you must observe the following.

- Using a razor blade and gasket scraper, remove all the old packing (FIPG) material from the gasket surfaces.
- Thoroughly clean all components to remove all the loose material.
- Clean both sealing surfaces with a non-residue solvent.
- Apply the seal packing in an approx. 1 mm (0.04 in.) bead along the sealing surface.
- Parts must be assembled within 10 minutes of application. Otherwise, the packing (FIPG) material must be removed and reapplied.

If the vehicle is equipped with a mobile communication system, refer to the precaution in the IN section.

PREPARATION

SST (SPECIAL SERVICE TOOLS)

	09032-00100	Oil Pan Seal Cutter	
	09308-10010	Oil Seal Puller	
	09325-40010	Transmission Oil Plug	
	09350-30020	TOYTOA Automatic Transmission Tool Set	
	(09351-32010)	One-way Clutch Test Tool	
	(09351-32020)	Stator Stopper	
	09843-18020	Diagnosis Check Wire	
	09990-01000	Engine Control Computer Check Harness "A"	
	09992-00094	Automatic Transmission Oil Pressure Gauge Set	

RECOMMENDED TOOLS

	09082-00050 TOYTOA Electrical Tester Set	
---	--	--

EQUIPMENT

Vernier calipers	Check torque converter clutch installation.
Dial indicator with magnetic base	Check drive plate runout.
Straight edge	Check torque converter clutch installation.
Torque wrench	

LUBRICANT

Item	Capacity	Classification
Automatic transmission fluid Dry fill Drain and refill	7.2 liter (7.6 US qts, 6.3 Imp.qts) 1.6 liter (1.7 US qts, 1.4 Imp.qts)	ATF DEXRON® II

SSM (SPECIAL SERVICE MATERIALS)

088260-0090 Seal Packing 1281. THREE BOND 1281 or equivalent (FIG)	Transmission X Oil pan
--	------------------------

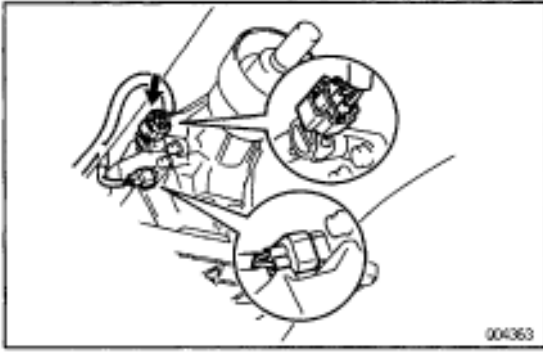

ON-VEHICLE REPAIR

NO.1 VEHICLE SPEED SENSOR ASSEMBLY REPLACEMENT

1. **DISCONNECT NO.1 VEHICLE SPEED SENSOR CONNECTOR**
2. **REMOVE NO.1 VEHICLE SPEED SENSOR ASSEMBLY**
 - (a) Remove the bolt and No.1 vehicle speed sensor assembly.
 - (b) Remove the speedometer driven gear from the No.1 vehicle speed sensor.
 - (c) Remove the O-ring from the No.1 vehicle speed sensor.
3. **INSTALL NO.1 VEHICLE SPEED SENSOR ASSEMBLY**
 - (a) Coat a new O-ring with A/T fluid and install it to the No.1 vehicle speed sensor.
 - (b) Install the speedometer driven gear to the No.1 vehicle speed sensor.
 - (c) Install the No.1 vehicle speed sensor to the extension housing and torque the bolt.
Torque: 16 N·m (160 kgf·cm, 12 ft·lbf)
4. **CONNECT NO.1 VEHICLE SPEED SENSOR CONNECTOR**

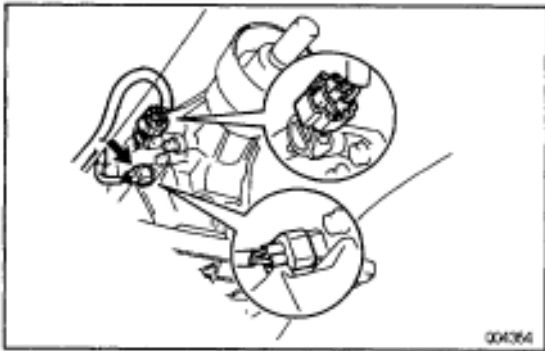

NO.2 VEHICLE SPEED SENSOR REPLACEMENT

1. **DISCONNECT NO.2 VEHICLE SPEED SENSOR CONNECTOR**
2. **REMOVE NO.2 VEHICLE SPEED SENSOR**
 - (a) Remove the bolt and No.2 vehicle speed sensor.
 - (b) Remove the O-ring.
3. **INSTALL NO.2 VEHICLE SPEED SENSOR**
 - (a) Coat a new O-ring with A/T fluid and install it to the No.2 vehicle speed sensor.
 - (b) Install the No.2 vehicle speed sensor to the extension housing and torque the bolt.
Torque: 5.4 N·m (55 kgf·cm, 48 in·lbf)
4. **CONNECT NO.2 VEHICLE SPEED SENSOR CONNECTOR**

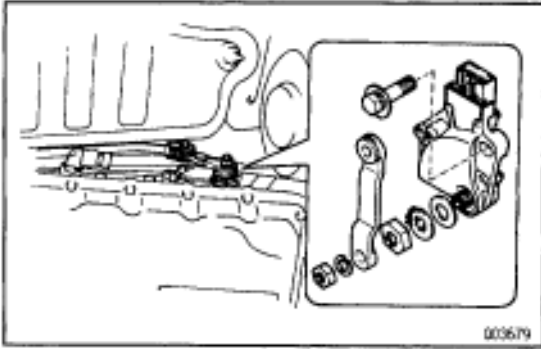

PARK/NEUTRAL POSITION SWITCH REPLACEMENT

1. REMOVE FRONT EXHAUST PIPE
(See page [EG-83](#))
2. DISCONNECT PARK/NEUTRAL POSITION SWITCH CONNECTOR
3. REMOVE PARK/NEUTRAL POSITION SWITCH
 - (a) Remove the control shaft lever.
 - (b) Pry off the lock washer and remove the nut.
 - (c) Remove the bolt and pull out the park/neutral position switch.
4. INSTALL AND ADJUST PARK/NEUTRAL POSITION SWITCH
5. CONNECT PARK/NEUTRAL POSITION SWITCH CONNECTOR
6. INSTALL FRONT EXHAUST PIPE
(See page [EG-127](#))



A/T FLUID TEMP. SENSOR REPLACEMENT

1. DISCONNECT A/T FLUID TEMP. SENSOR CONNECTOR
2. REMOVE A/T FLUID TEMP. SENSOR
 - (a) Remove the A/T fluid temp. sensor.
 - (b) Remove the O-ring.
3. INSTALL A/T FLUID TEMP. SENSOR
 - (a) Coat a new O-ring with A/T fluid and install it to the A/T fluid temp. sensor.
 - (b) Install the A/T fluid temp. sensor.
·Torque: 15 N·m (150 kgf·cm, 11 ft·lbf)
4. CONNECT A/T FLUID TEMP. SENSOR CONNECTOR

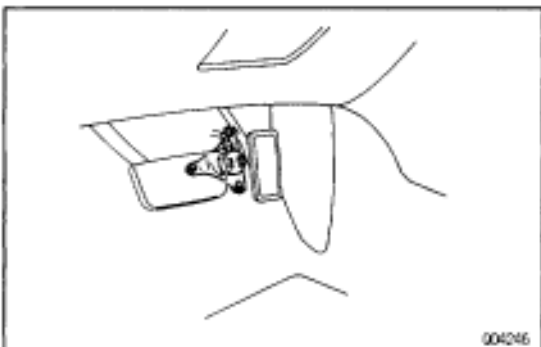

KICK-DOWN SWITCH REPLACEMENT

1. REMOVAL OF KICK-DOWN SWITCH
 - (a) Remove the 3 bolts and kick-down switch.
 - (b) Disconnect the kick-down switch connector.
2. INSTALLATION OF KICK-DOWN SWITCH
 - (a) Connect the kick-down switch connector.
 - (b) Install the kick-down switch and 3 bolts.

VALVE BODY REMOVAL

Installation is in the reverse order of removal.

INSTALLATION HINT: After installation, fill A/T fluid and check fluid level. (See page AT1-42)

1. RAISE VEHICLE AND CLEAN TRANSMISSION EXTERIOR

To prevent contamination, clean the exterior of the transmission.

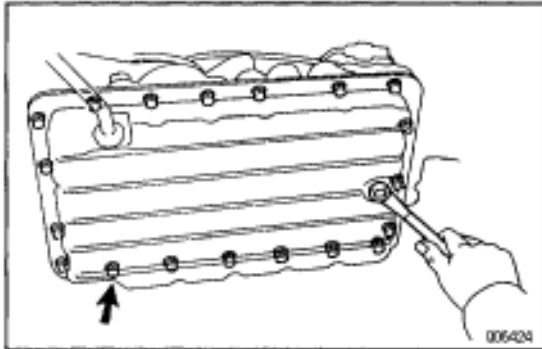

2. DRAIN TRANSMISSION

Remove the drain plug and drain fluid into a suitable container.

Torque: 20 N·m (205 kgf·cm, 15 ft·lbf)

3. REMOVE OIL PAN

REMOVAL NOTICE: Some fluid will remain in the oil pan.

(a) Remove the 19 bolts.

Torque: 7.4 N·m (75 kgf·cm, 65 in·lbf)

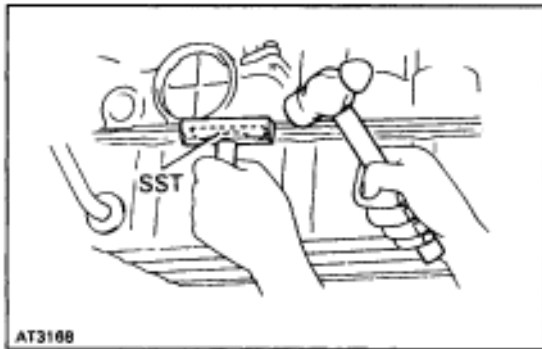

(b) Install the blade of SST between the transmission case and oil pan, cut off applied sealer and then remove the oil pan.

SST 09032-00100

REMOVAL NOTICE: When removing the oil pan, be careful not to damage the oil pan flange.

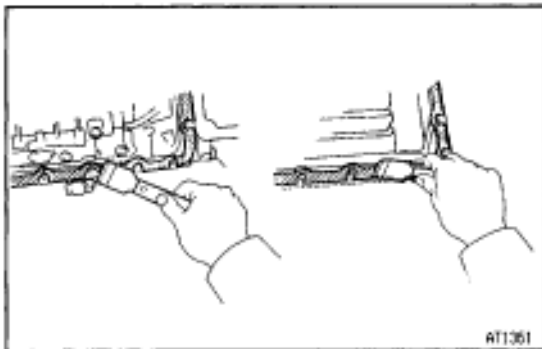

INSTALLATION HINT:

- Remove any packing material and be careful not to drop oil on the contacting surfaces of the oil pan and transmission case.
- Clean contacting surfaces of any residual packing material using gasoline or alcohol.

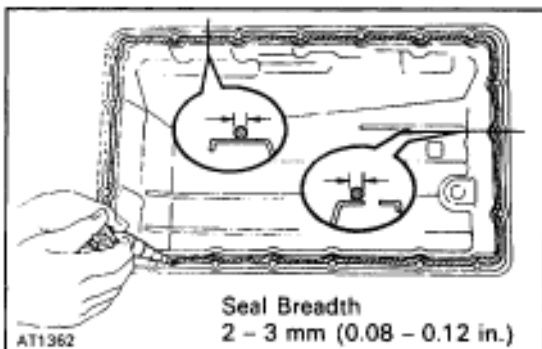

- Apply FIPG to the oil pan.

FIPG:

Part No. 08826-00090, THREE BOND 1281 or equivalent

- Install the oil pan within 10 minutes after applying FIPG.

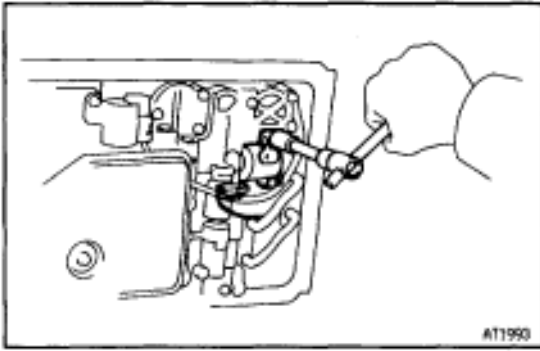

4. WHEN REPLACING 3 SOLENOIDS

- (a) Disconnect the connectors from the solenoids.
- (b) Remove the solenoid mounting bolts.
Torque: 10 N·m (100 kgf·cm, 7 ft·lbf)
- (c) Remove the solenoids.

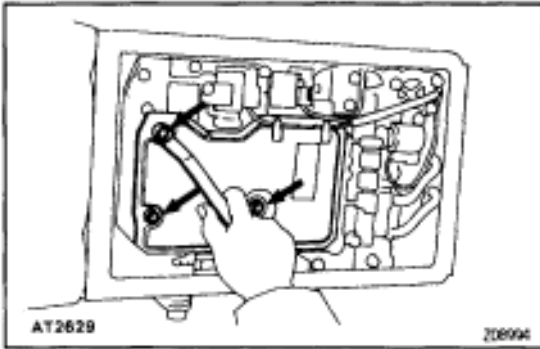

5. REMOVE OIL STRAINER

REMOVAL NOTICE: Be careful as some fluid will come out with the oil strainer.

Remove the 3 bolts, and the oil strainer and gasket.
Torque: 10 N·m (100 kgf·cm, 7 ft·lbf)

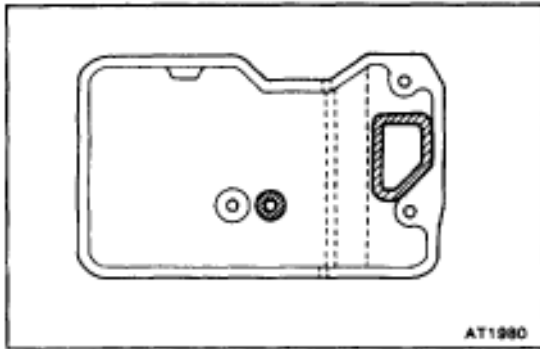

INSTALLATION HINT: If necessary, replace the strainer or case gasket.

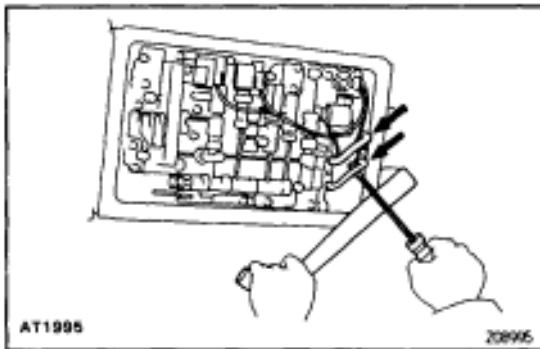

6. REMOVE OIL PIPES

Pry up both pipe ends with a large screwdriver and remove the 2 pipes.

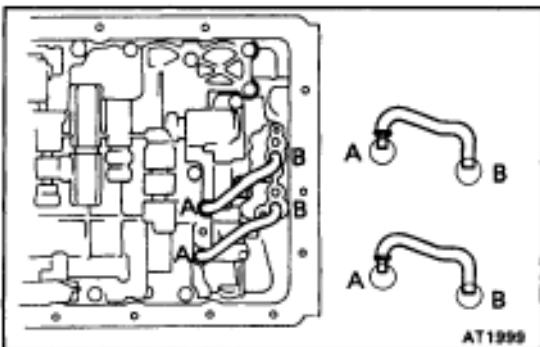

INSTALLATION NOTICE: Make sure that the oil pipes or the magnets do not interfere with the oil pan.

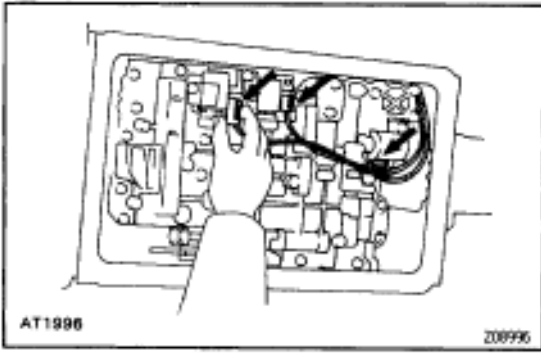

7. DISCONNECT CONNECTORS FROM EACH SOLENOID

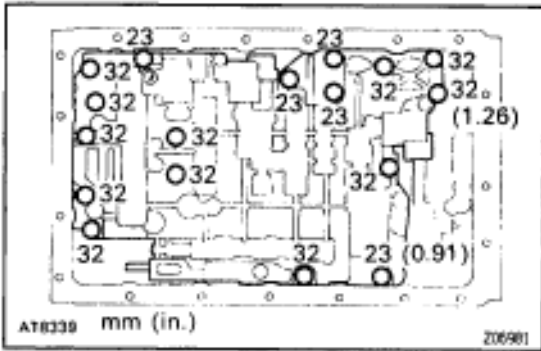

8. REMOVE VALVE BODY

(a) Remove the 17 bolts.

Torque: 10 N·m (100 kgf·cm, 7 ft·lbf)

INSTALLATION HINT: Each bolt length is indicated in the illustration.

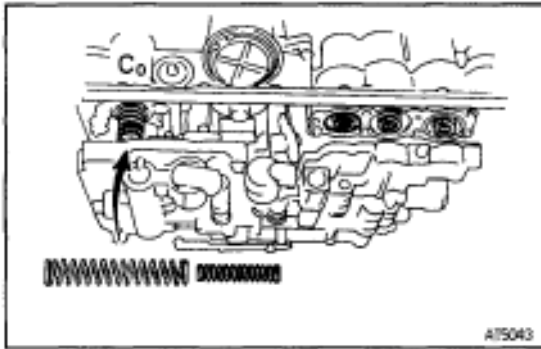

(b) Remove the 2 C₀ accumulator piston springs.

- **C₀ accumulator piston spring**

Spring	Outer	Inner
Free length	74.6 (2.937)	46.0 (1.811)
Outer diameter	20.9 (0.823)	14.0 (0.551)
Color	Orange	Yellow

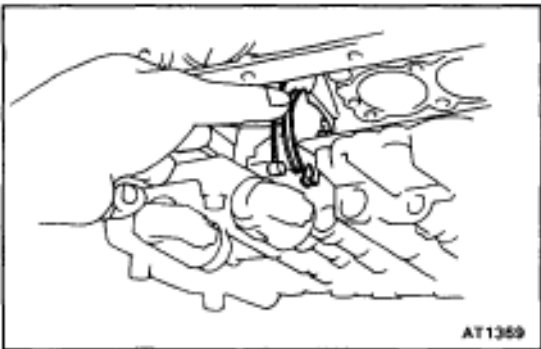

(c) Disconnect the throttle cable from the cam.

(d) Remove the valve body.

REMOVAL HINT: Be careful not to drop the check ball body and spring.

INSTALLATION HINT:

- Install the body together the check ball body and spring.
- Align the groove of the manual valve to the pin of the lever.

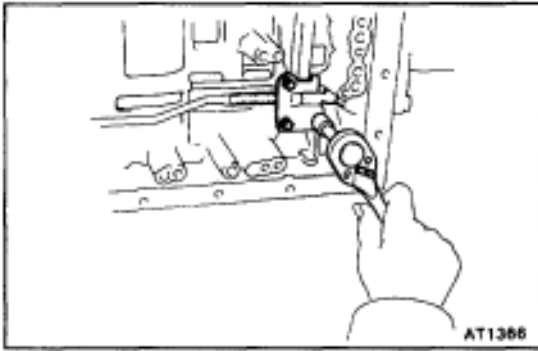

PARKING LOCK PAWL REMOVAL

Installation is in the reverse order of removal.

1. REMOVE VALVE BODY (See page AT1-16)
2. REMOVE PARKING LOCK PAWL BRACKET

INSTALLATION HINT:

- Push the lock rod fully forward.
- Install the 3 bolts finger tight.
- Check that the parking lock pawl operates smoothly.

Torque: 7.4 N·m (75 kgf·cm, 65 in·lbf)

3. REMOVE SPRING FROM PARKING LOCK PAWL SHAFT

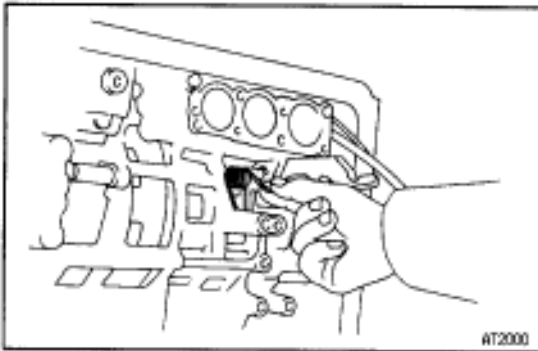

4. REMOVE PARKING LOCK PAWL AND SHAFT

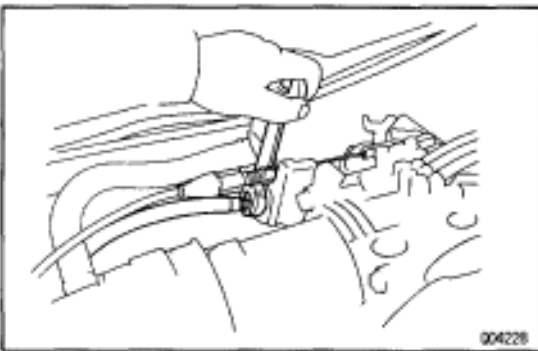
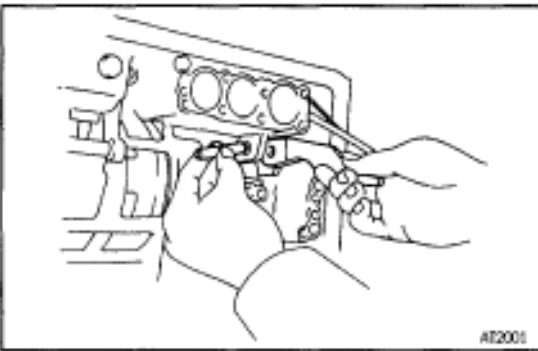

THROTTLE CABLE REPLACEMENT

1. DISCONNECT THROTTLE CABLE

- (a) Disconnect the cable housing from the bracket.
- (b) Disconnect the cable from the throttle linkage.



- (c) Disconnect the cable from the torque converter clutch housing.

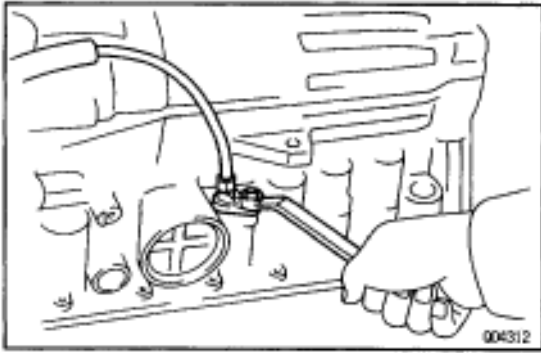

2. **REMOVE VALVE BODY**
(See page [AT1-16](#))
3. **PUSH THROTTLE CABLE OUT OF TRANSMISSION CASE**
Remove the retaining bolt and pull out the throttle cable.
4. **INSTALL THROTTLE CABLE**
Install the retaining bolt and push in the throttle cable.
5. **INSTALL VALVE BODY**
(See page [AT1-16](#))

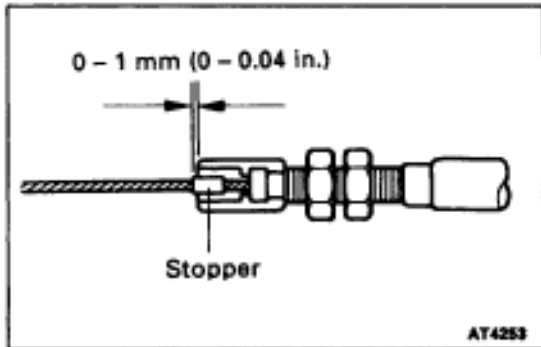

6. **IF THROTTLE CABLE IS NEW, STAKE STOPPER ON INNER CABLE**
 - (a) Pull in the slack of the inner cable.
 - (b) Stake the stopper, as shown, 0–1 mm (0–0.04 in.) from the end of outer cable.

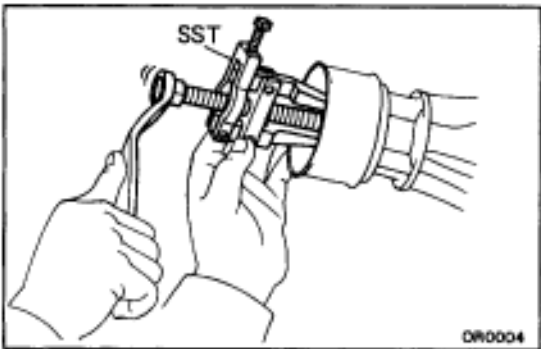

OIL SEAL REPLACEMENT

1. **RAISE VEHICLE AND POSITION PAN TO CATCH ANY FLUID THAT MAY DRIP**
2. **REMOVE PROPELLER SHAFT TOGETHER WITH CENTER BEARING**
3. **REMOVE REAR OIL SEAL**
NOTICE: Clean the extension housing before removing the oil seal.

Using SST, remove the oil seal.

SST 09308-10010

4. **INSTALL NEW OIL SEAL**
Using SST and a hammer, drive in a new oil seal as far as it will go.
SST 09325-40010
5. **INSTALL PROPELLER SHAFT**
6. **LOWER VEHICLE AND CHECK FLUID LEVEL**

(See page [AT1-42](#))

Add fluid as necessary.

NOTICE: Do not overfill.

Fluid type:

ATF DEXRON® II

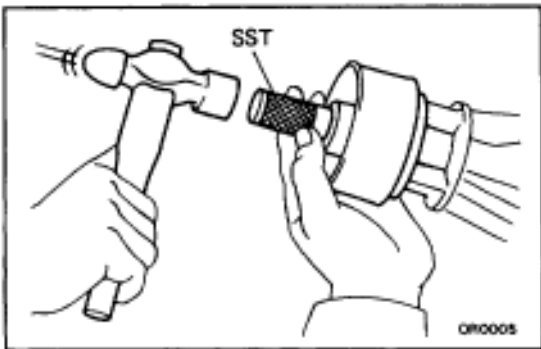

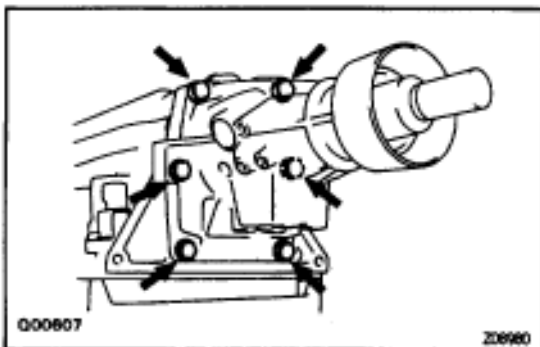
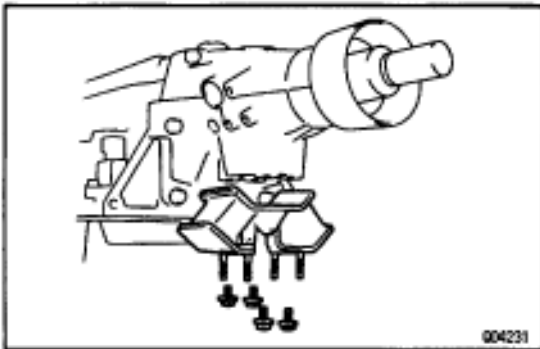
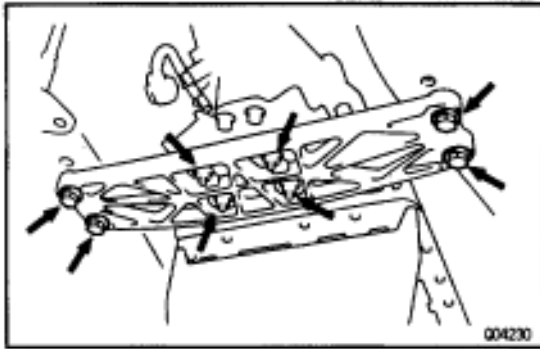
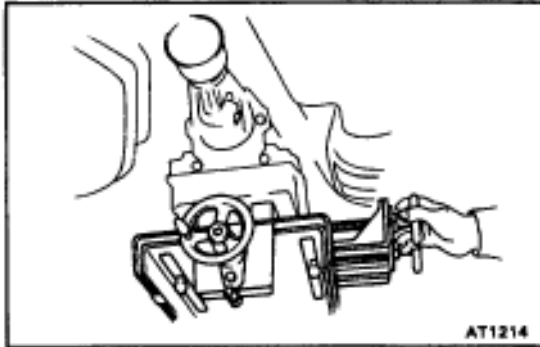
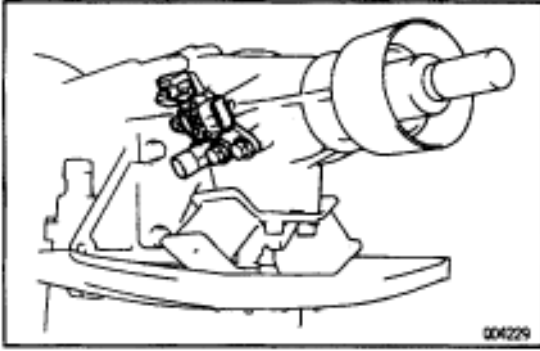

EXTENSION HOUSING REMOVAL

Installation is in the reverse order of removal.

INSTALLATION HINT: After installation, fill A/T fluid and check fluid level. (See page [AT1-42](#))

1. **RAISE VEHICLE AND POSITION PAN TO CATCH ANY FLUID THAT MAY DRIP**
2. **REMOVE PROPELLER SHAFT TOGETHER WITH CENTER BEARING.**
3. **DISCONNECT NO. 1 AND NO. 2 VEHICLE SPEED SENSOR CONNECTORS AND REMOVE SENSORS**
4. **REMOVE SPEEDOMETER DRIVEN GEAR**
5. **JACK UP TRANSMISSION SLIGHTLY**

Securely support the transmission on a transmission jack. Lift the transmission slightly to remove weight from the rear support member.

6. **REMOVE REAR SUPPORT MEMBER**
Remove the 4 bolts, nuts and support member.
Torque: 25 N·m (260 kgf·cm, 19 ft·lbf)

7. **REMOVE TRANSMISSION MOUNTING BRACKET**
Remove the 4 bolts and bracket from the transmission.
Torque: 25 N·m (250 kgf·cm, 18 ft·lbf)

8. **REMOVE EXTENSION HOUSING AND GASKET**
Remove the 6 bolts. If necessary, tap the extension housing with a plastic hammer or block of wood to loosen it.
INSTALLATION HINT: The 2 lower bolts are shorter.
Torque: 36 N·m (370 kgf·cm, 27 ft·lbf)

ASSEMBLY REMOVAL AND INSTALLATION

Remove and install the part, as shown.

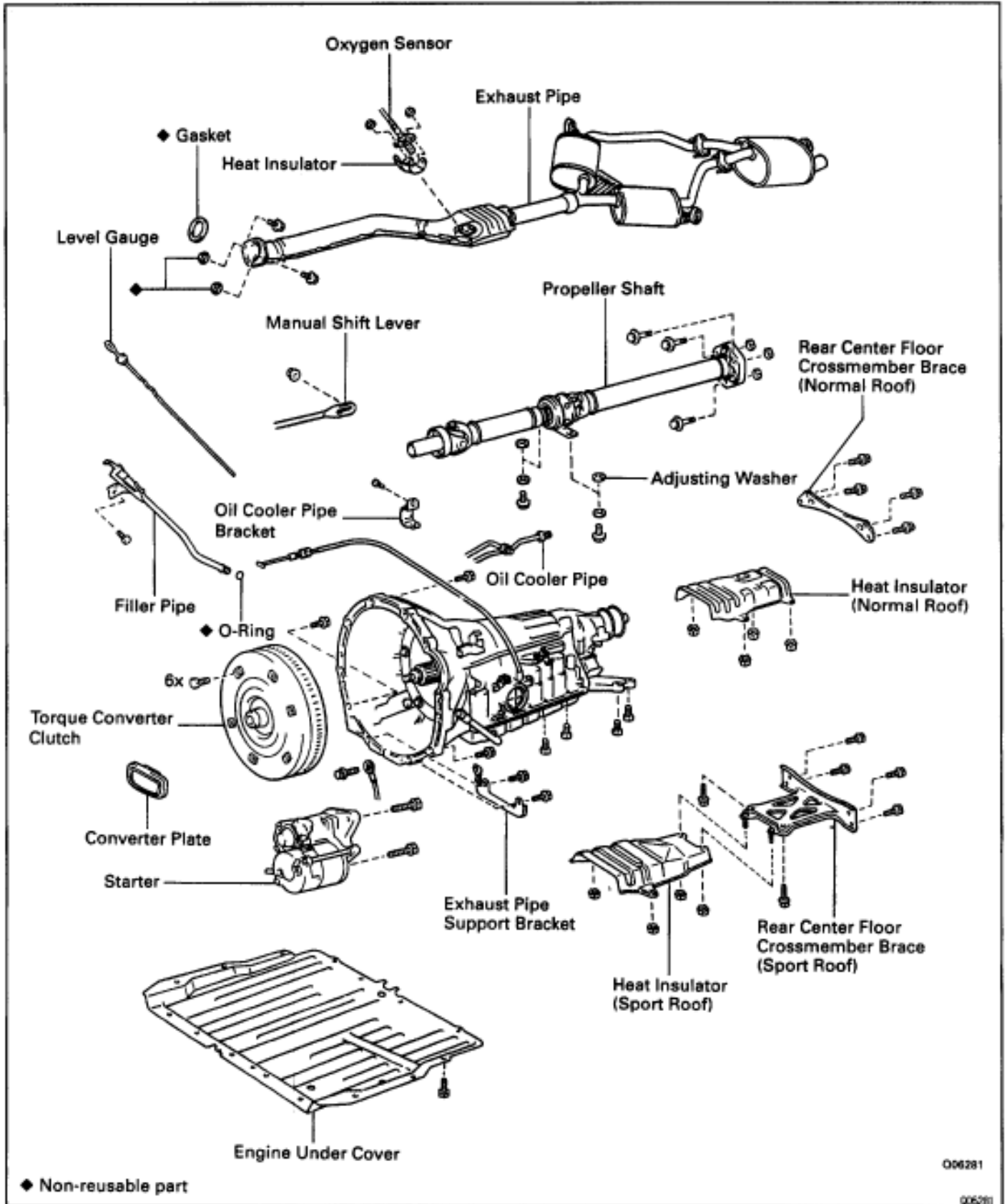

TRANSMISSION REMOVAL

Installation is in the reverse order of removal.

INSTALLATION HINT: After installation, fill A/T fluid and check fluid level. (See page [AT1-42](#))

1. **REMOVE A/T FLUID LEVEL GAUGE**
2. **REMOVE FILLER PIPE**
Remove the bolt and pipe.



3. **DISCONNECT THROTTLE CABLE**

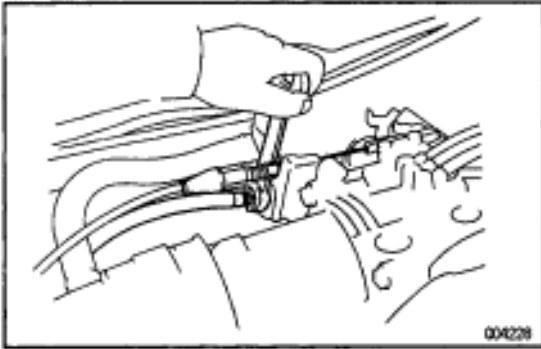

4. **REMOVE EXHAUST PIPE**
(See page [EG-83](#))

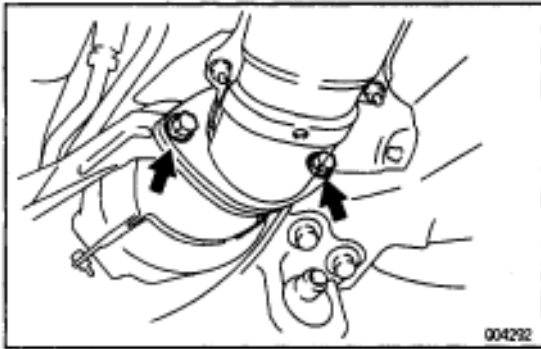

5. **REMOVE HEAT INSULATOR**
Remove the 4 nuts and the heat insulator.
Torque: 5.4 N·m (55 kgf·cm, 48 in·lbf)

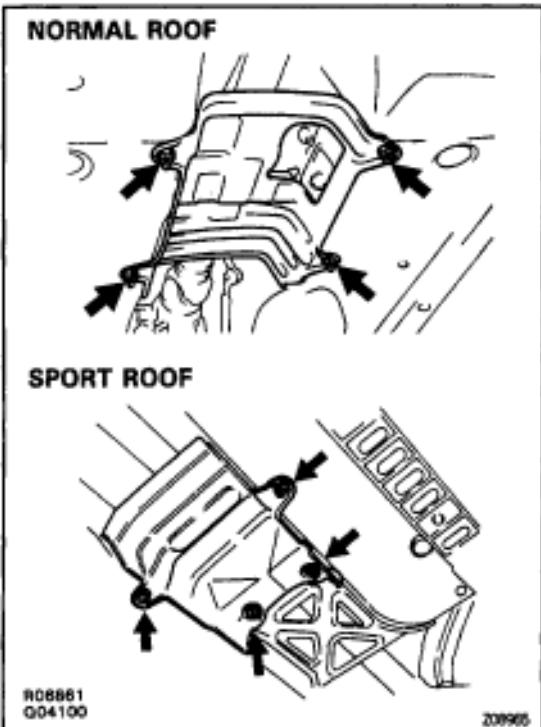

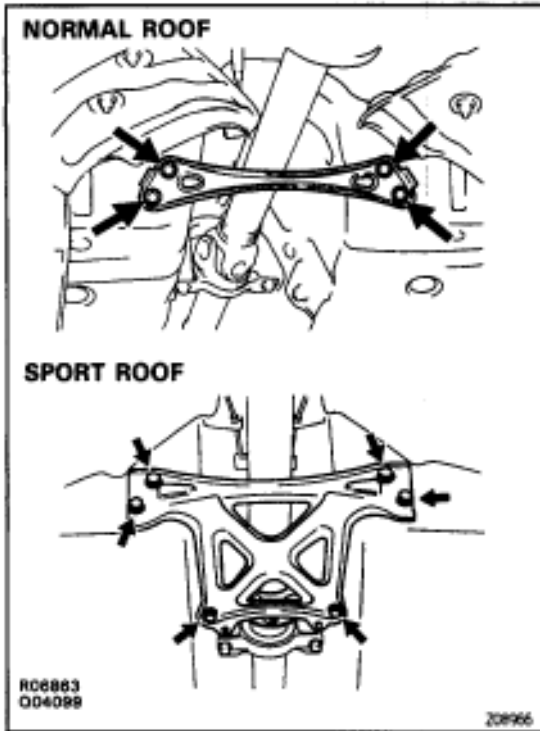

6. REMOVE REAR CENTER FLOOR CROSSMEMBER BRACE

Normal Roof:

Remove the 4 bolts and center floor crossmember brace.

Torque: 13 N·m (130 kgf·cm, 9 ft·lbf)

Sport Roof:

Remove the 6 bolts and center floor crossmember brace.

Torque: 13 N·m (130 kgf·cm, 9 ft·lbf)

7. REMOVE PROPELLER SHAFT

(See page [PR-7](#))

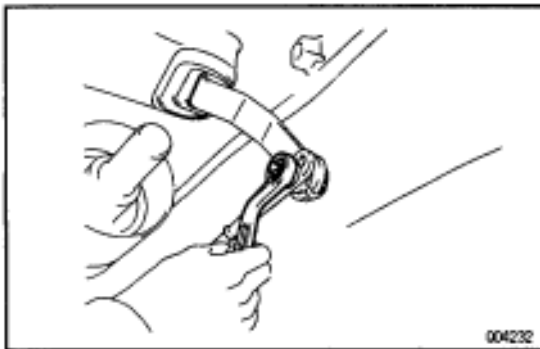

8. REMOVE SHIFT CONTROL ROD

(a) Remove the nut from shift lever.

INSTALLATION HINT: Inspect and adjust the park/ neutral position switch.

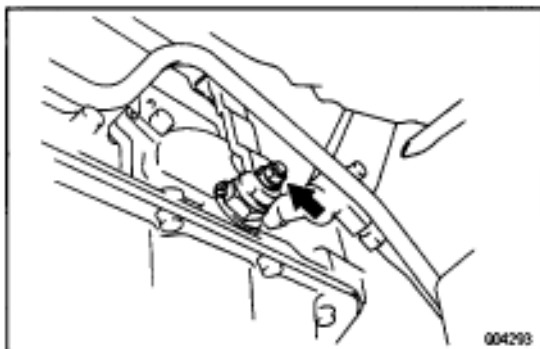

(b) Remove the nut and control rod with the control shaft lever.

Torque: 16 N·m (160 kgf·cm, 12 ft·lbf)

9. DISCONNECT THESE CONNECTORS

- No.1 vehicle speed sensor connector
- No.2 vehicle speed sensor connector
- Solenoid wire connector
- Sensor cover
- A/T fluid temp. sensor connector
- Park/neutral position switch connector

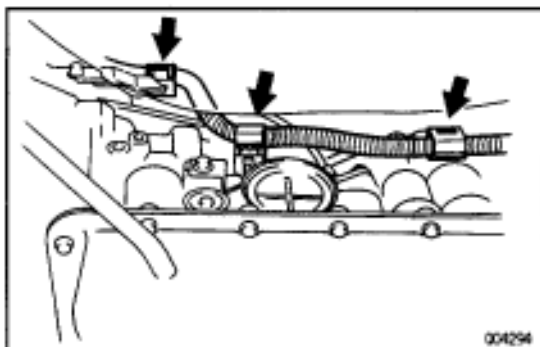

10. DISCONNECT 3 WIRE CLAMPS FROM THE BRACKET ON TRANSMISSION

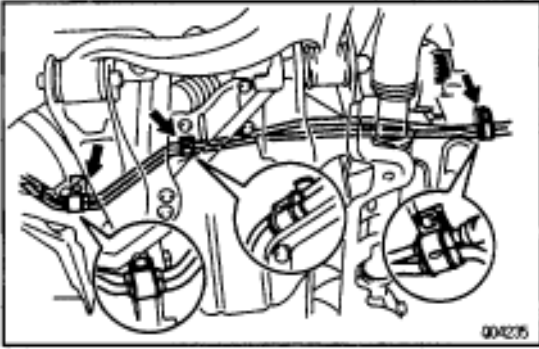

11. DISCONNECT OIL COOLER PIPES

- (a) Remove the 3 bolts and oil cooler pipe clamps.

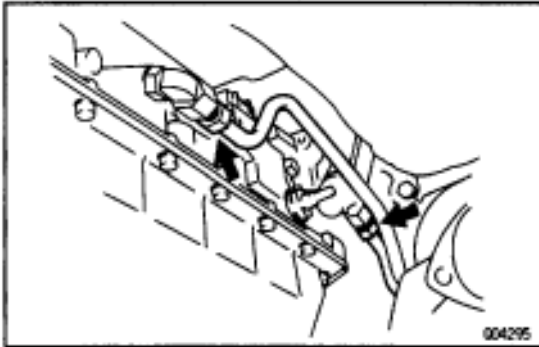

- (b) Disconnect the 2 oil cooler pipes.
Torque: 34 N·m (350 kgf·cm, 25 ft·lbf)

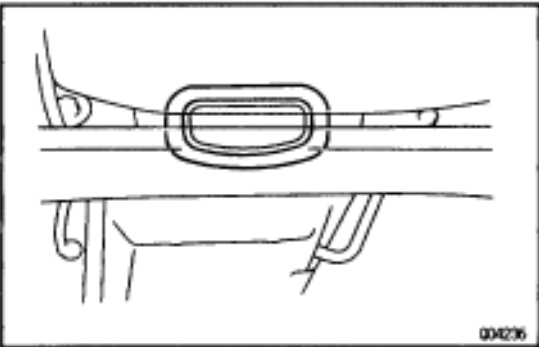

12. REMOVE TORQUE CONVERTER CLUTCH MOUNTING BOLTS

- (a) Remove the engine under cover.
(b) Remove the converter plate.

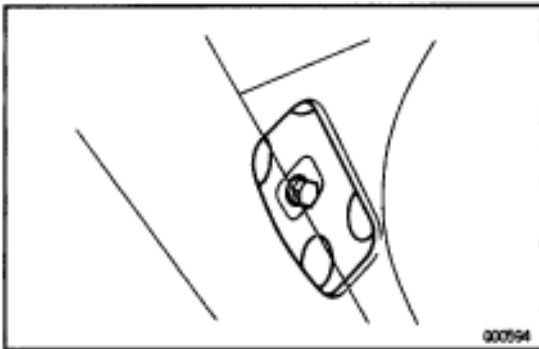

- (c) Turn the crankshaft to gain access to each bolt.
Remove the 6 bolts.
Torque: 33 N·m (340 kgf·cm, 25 ft·lbf)

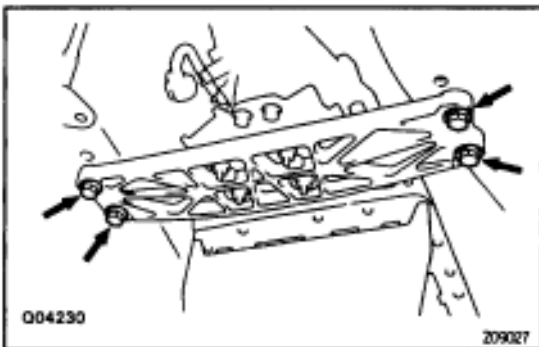

13. JACK UP TRANSMISSION

14. REMOVE REAR MOUNTING

- Remove the 4 bolts and rear mounting.
Torque: 25 N·m (260 kgf·cm, 19 ft·lbf)

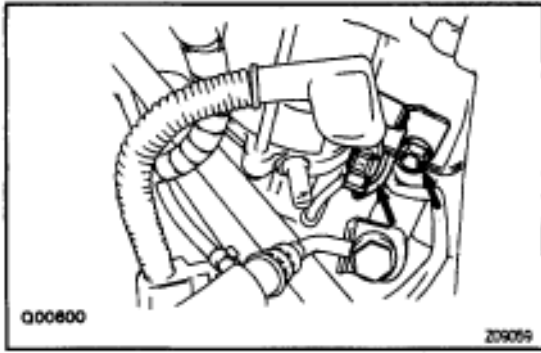

15. REMOVE STARTER

- (a) Disconnect the connector.
- (b) Remove the nut and cable.

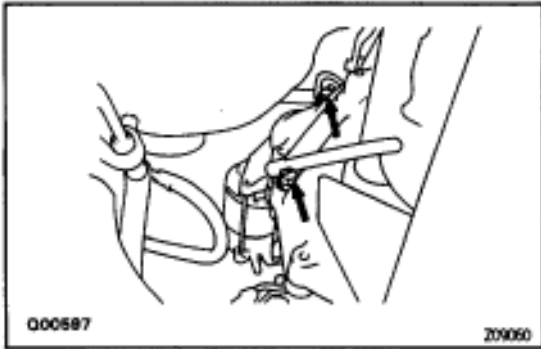

- (c) Remove the 2 bolts and starter.
Torque: 37 N·m (380 kgf·cm, 27 ft·lbf)

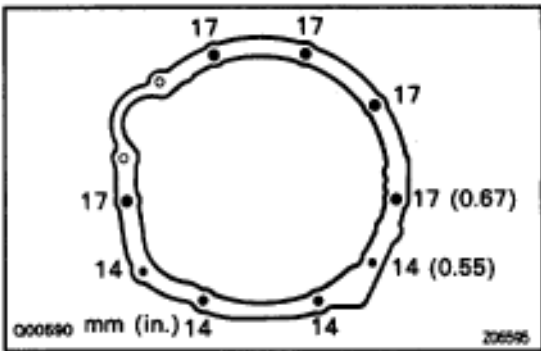

16. REMOVE TRANSMISSION

Remove the 9 bolts and transmission.

Torque:

- 14 mm head bolt: 37 N·m (380 kgf·cm, 27 ft·lbf)
- 17 mm head bolt: 72 N·m (730 kgf·cm, 53 ft·lbf)

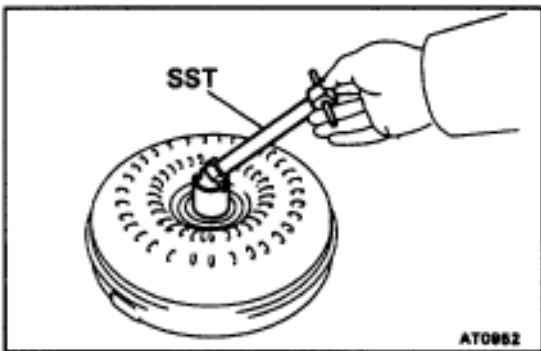

TORQUE CONVERTER CLUTCH AND DRIVE PLATE INSPECTION

1. INSPECT ONE-WAY CLUTCH

- (a) Install SST in the inner race of one-way clutch.
SST 09350-30020 (09351-32010)

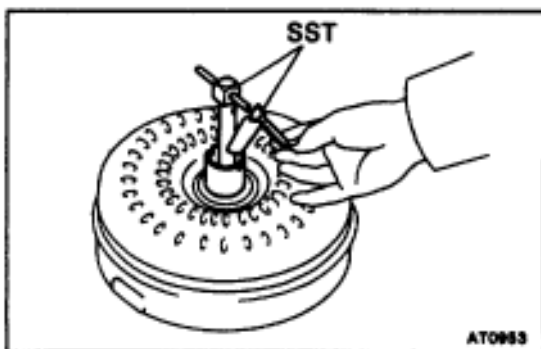

- (b) Install SST so that it fits in the notch of the converter hub and outer race of the one-way clutch.
SST 09350-30020 (09351-32020)

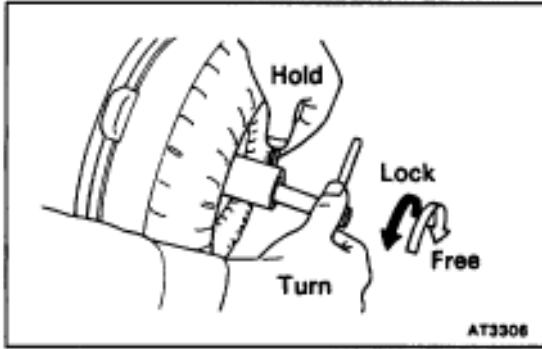

- (c) With the torque converter clutch standing on its side the clutch should lock when turned counterclockwise, and rotate freely and smoothly clockwise.

If necessary, clean the converter clutch and retest the clutch. Replace the converter if the clutch still fails the test.

2. MEASURE DRIVE PLATE RUNOUT AND INSPECT RING GEAR

Set up a dial indicator and measure the drive plate runout.

Maximum runout:

0.20 mm (0.0079 in.)

If runout exceeds 0.20 mm (0.0079 in.) or if the ring gear is damaged, replace the drive plate. If installing a new drive plate, note the orientation of spacers and tighten the bolts.

Torque: 74 N·m (750 kgf·cm, 54 ft·lbf)

3. MEASURE TORQUE CONVERTER CLUTCH SLEEVE RUNOUT

- (a) Temporarily mount the torque converter clutch to the drive plate. Set up a dial indicator.

Maximum runout:

0.30 mm (0.0118 in.)

If runout exceeds 0.30 mm (0.0118 in.), try to correct by reorienting the installation of the converter clutch. If excessive runout cannot be corrected, replace the torque converter clutch.

HINT: Mark the position of the converter clutch to ensure correct installation.

- (b) Remove the torque converter clutch.

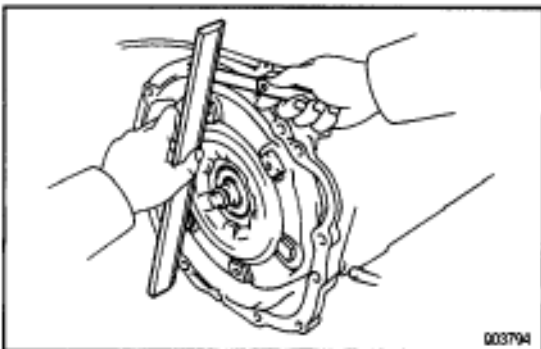
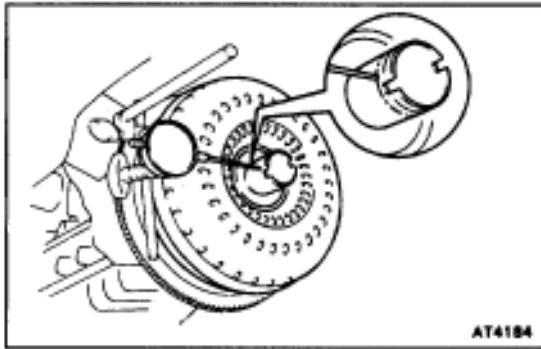
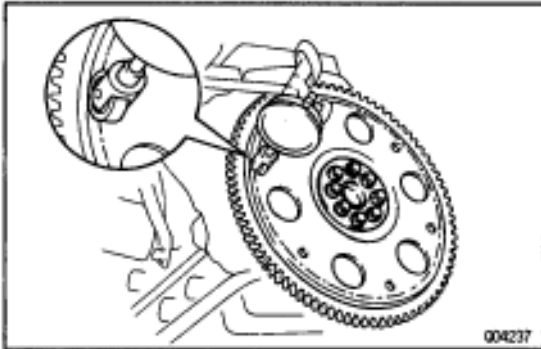

TORQUE CONVERTER CLUTCH INSTALLATION

1. INSTALL TORQUE CONVERTER CLUTCH TRANSMISSION

2. CHECK TORQUE CONVERTER CLUTCH INSTALLATION

Using feeler gauge and a straight edge, measure between the installed surface of the transmission and the straight edge.

Clearance:

Less than 0.1 mm (0.004 in.)

SHIFT LOCK SYSTEM COMPONENT PARTS LOCATION

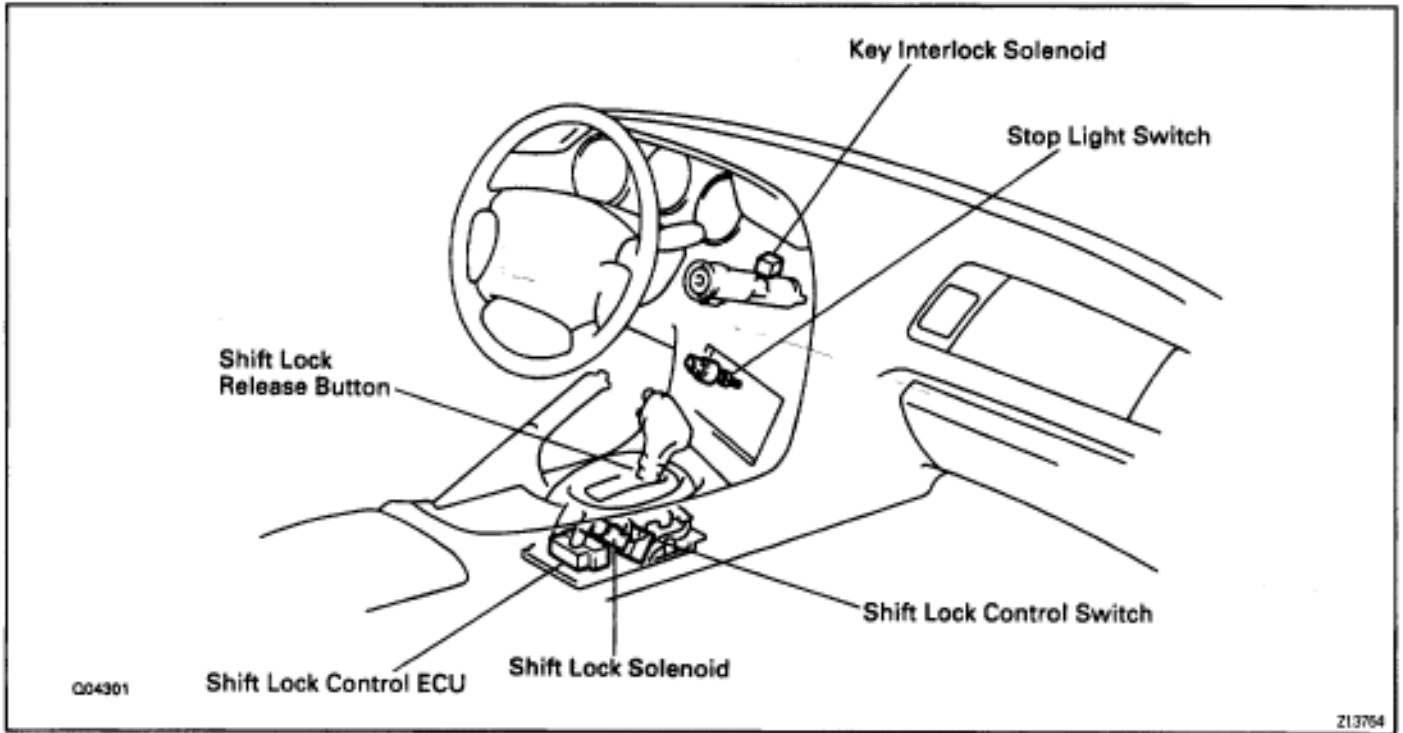

WIRING DIAGRAM

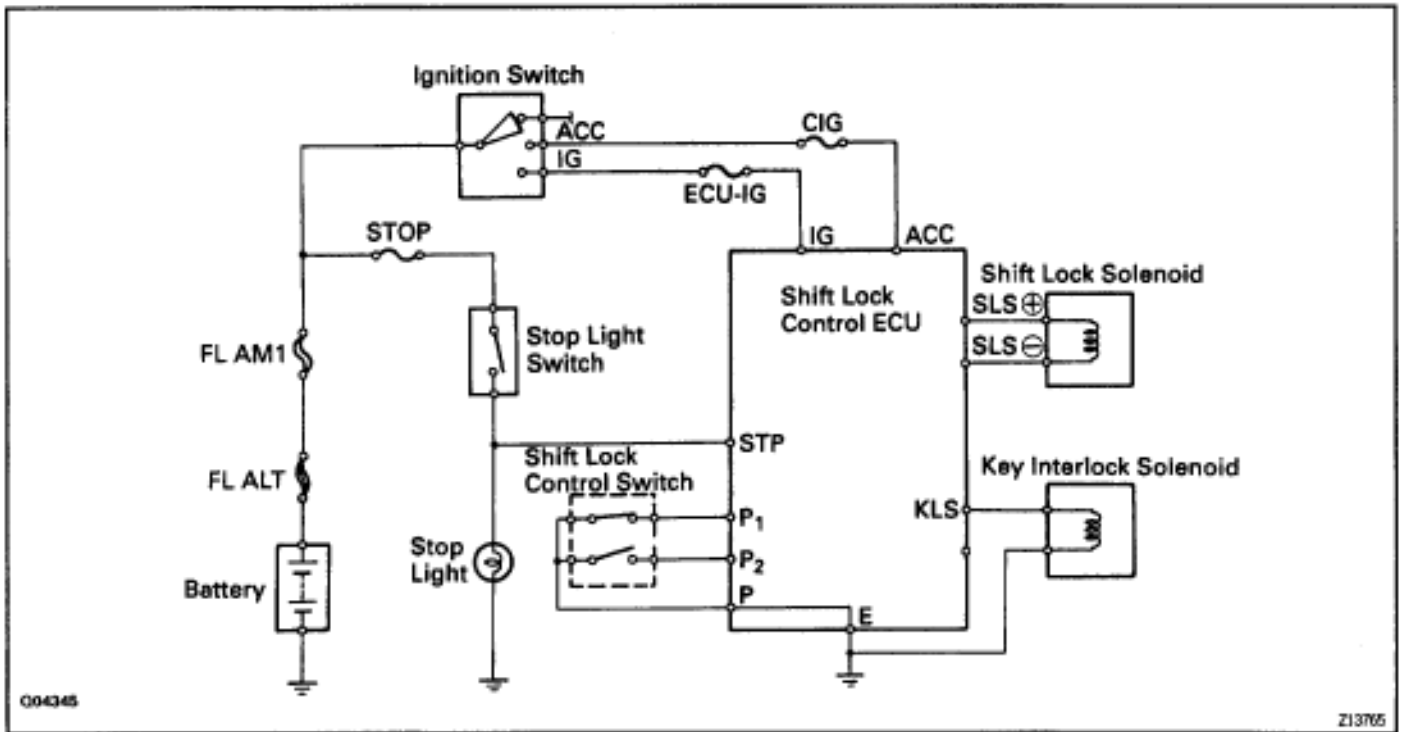

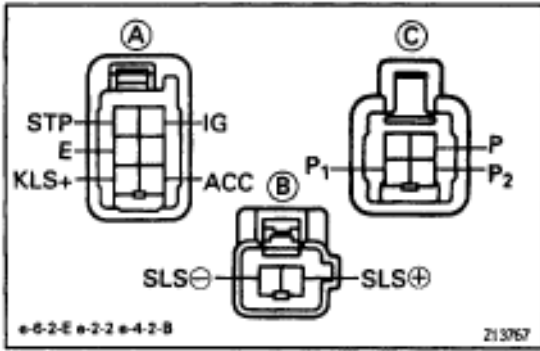

ELECTRONIC CONTROL COMPONENTS INSPECTION

1. INSPECT SHIFT LOCK CONTROL ECU

Using a voltmeter, measure the voltage at each terminal.

Connector	Terminal	Measuring condition		Voltage (V)
A	ACC - E	IG SW ACC		10 - 14
	IG - E	IG SW ON		10 - 14
	STP - E	Depress brake pedal		10 - 14
	KLS - E	(1)	IG SW ACC and P position	Below 1
(2)		R, N, D, 2, L position	7.5 - 11	
(3)		R, N, D, 2, L position (after 1 second)	6 - 9.5	
B	SLS (-) - SLS (+)	(1)	IG SW ON and P position	Below 1
		(2)	Depress brake pedal	8 - 13.5
		(3)	Depress brake pedal (after 20 seconds)	6 - 8.5
		(4)	R, N, D, 2, L position	Below 1
C	P ₁ - P	(1)	IG SW ON, P position and depress brake pedal	Below 1
		(2)	R, N, D, 2, L position	9 - 13.5
	P ₂ - P	(1)	IG SW ACC and P position	9 - 13.5
		(2)	R, N, D, 2, L position	Below 1

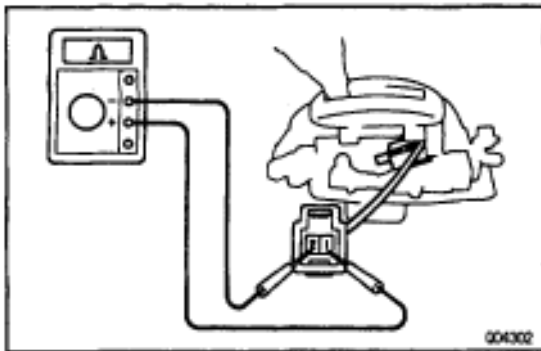

2. INSPECT SHIFT LOCK SOLENOID

- (a) Disconnect the solenoid connector.
- (b) Using an ohmmeter, measure the resistance between terminals 1 and 2.

Standard resistance:

20-28 Ω

If resistance value is not as specified, replace the solenoid.

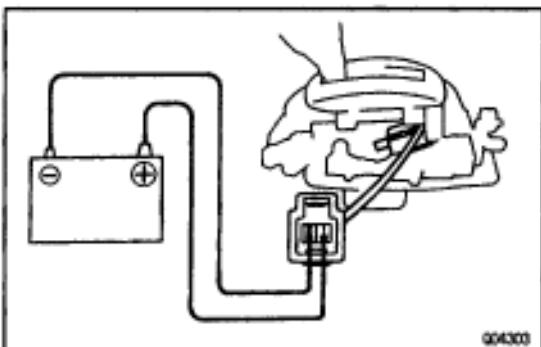

- (c) Apply battery positive voltage between terminals 1 and 2. At this time, confirm that the solenoid operates. If the solenoid does not operate, replace the solenoid.

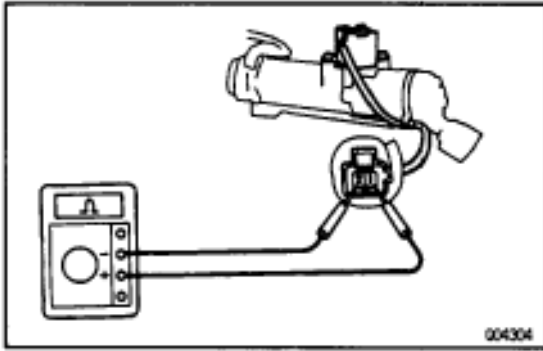

3. INSPECT KEY INTERLOCK SOLENOID

- (a) Disconnect the solenoid connector.
- (b) Using an ohmmeter, measure the resistance between terminals 1 and 2.

Standard resistance:

12–17 Ω

If resistance value is not as specified, replace the solenoid.

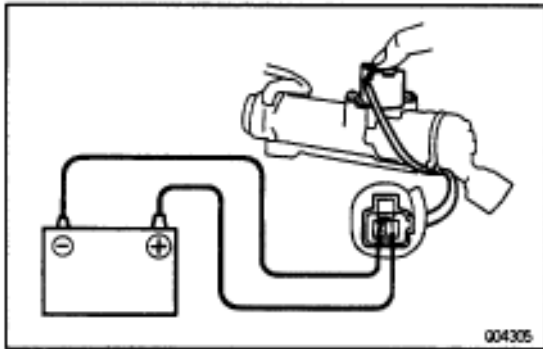

- (c) Touch the solenoid with your finger and check that solenoid operation can be felt when battery positive voltage is applied intermittently to the terminals 1 and 2.

If the solenoid does not operate, replace the solenoid.

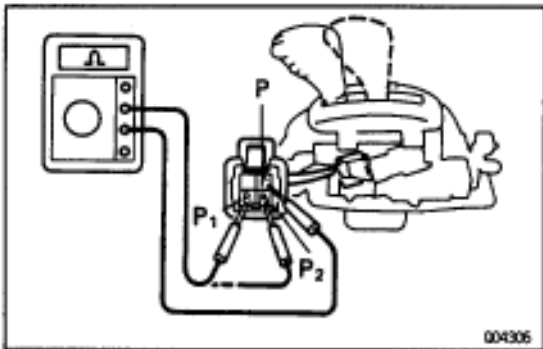

4. INSPECT SHIFT LOCK CONTROL SWITCH

Inspect that there is continuity between each terminal.

Shift position	Tester condition to terminal number	Specified value
P position (Release button is not pushed)	P-P ₁	Continuity
R, N, D, 2, L position	P-P ₂	Continuity

TROUBLESHOOTING

HOW TO PROCEED WITH TROUBLESHOOTING

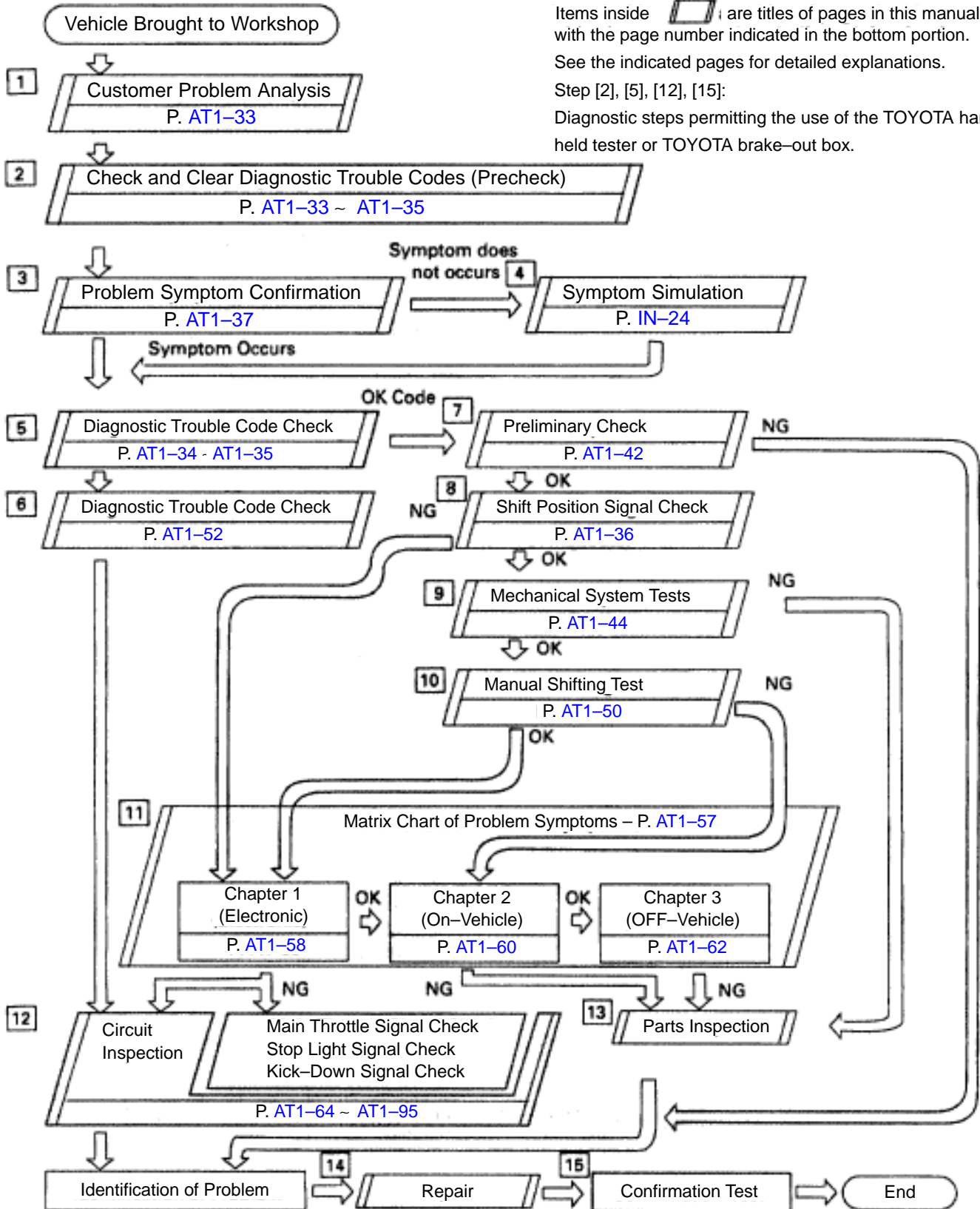

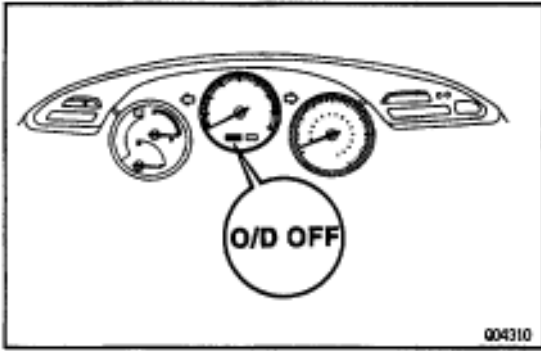

DIAGNOSIS SYSTEM

The Electronically Controlled Transmission has built-in self-diagnostic functions. If a malfunction occurs in the system, the ECM stores the diagnostic trouble code in memory and the O/D OFF (Overdrive OFF) indicator light blinks to inform the driver. The diagnostic trouble code stored in memory can be read out by the following procedure.

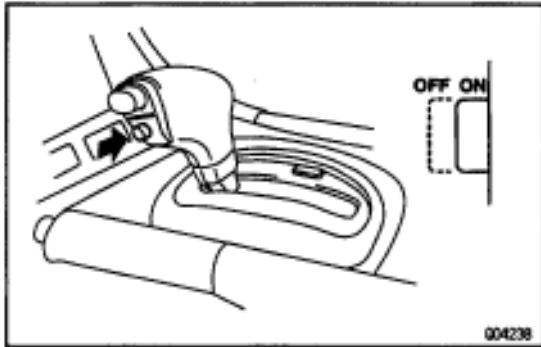

O/D OFF INDICATOR LIGHT INSPECTION

1. Turn the ignition switch ON.
2. Check if the O/D OFF indicator light lights up when the O/D main switch is pushed out to OFF and goes off when the O/D main switch is pushed in to ON.

HINT: If the O/D OFF indicator light does not light up or stay on all the time, carry out the check for "O/D OFF Indicator Light Circuit" on page [AT1-88](#).

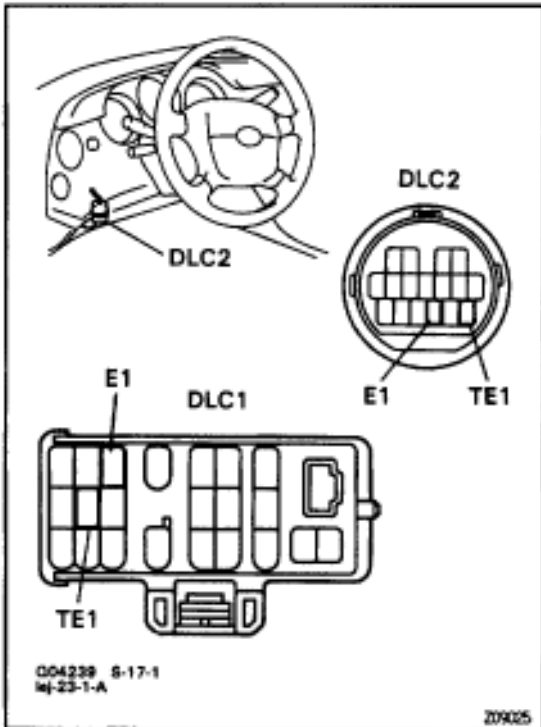

DIAGNOSTIC TROUBLE CODE CHECK

1. Turn the ignition switch ON, but do not start the engine.
2. Push in the O/D main switch to ON.
HINT: Warning and diagnostic trouble codes can be read only when the O/D main switch is ON. If it is OFF, the O/D OFF indicator light up will light continuously and will not blink.
3. Using SST, connect terminals TE1 and E1 of the DLC 1 or DLC2.

SST 09843-18020

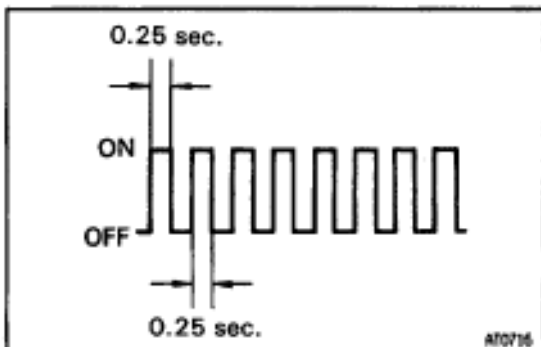

4. Read the diagnostic trouble code indicated by the number of times the O/D OFF indicator light blinks.

HINT: If the system is operating normally, the light will blink 2 times per second.

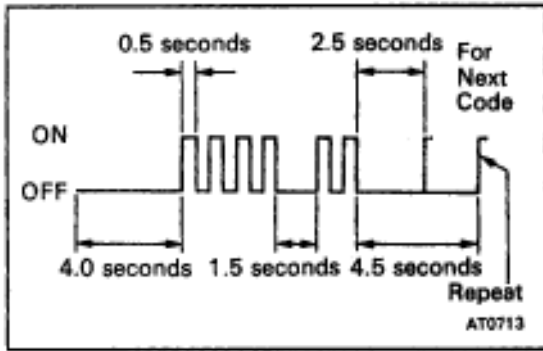

The trouble code is indicated, as shown in the illustration at left (Diagnostic trouble code "42" is shown as an example).

HINT: When 2 or more trouble codes are stored in memory, the lower-numbered code is displayed first. If no diagnostic trouble code is output, or if a diagnostic trouble code is output even though no diagnostic trouble code output operation is performed, check the TE 1 terminal circuit on page [AT1-93](#).

DIAGNOSTIC TROUBLE CODE CHECK BY USING TOYOTA HAND-HELD TESTER

1. Hook up the TOYOTA hand-held tester to the DLC2.
2. Read the diagnostic trouble codes by following the prompts on the tester screen.

Please refer to the TOYOTA hand-held tester operator's manual for further details.

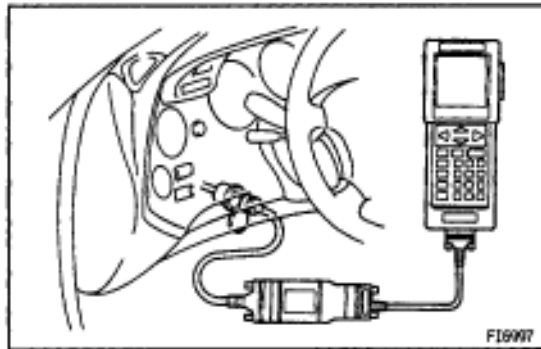

CANCELING DIAGNOSTIC TROUBLE CODE

After repair of the trouble area, the diagnostic trouble code retained in the ECM memory must be canceled out by removing the EFI fuse for 10 seconds or more, with the ignition switch OFF.

Check that the normal code is output after connecting the fuse.

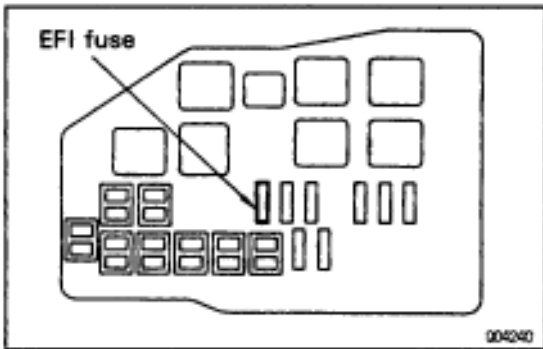

ECM TERMINALS STANDARD VALUE

ECM TERMINAL VALUES

MEASUREMENT BY USING TOYOTA BREAK-OUT BOX AND TOYOTA HAND-HELD TESTER

1. Hook up the TOYOTA break-out-box and TOYOTA hand-held tester to the vehicle.
2. Read the ECM input/output values by following the prompts on the tester screen.

HINT: TOYOTA hand-held tester has a "Snapshot" function. This records the measured values and is effective in the diagnosis of intermittent problems.

Please refer to the TOYOTA hand-held tester / TOYOTA break-out box operator's manual for further details.

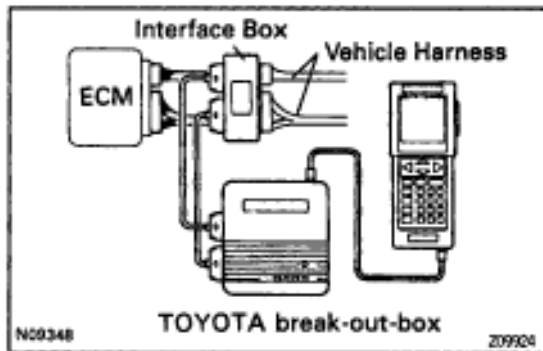

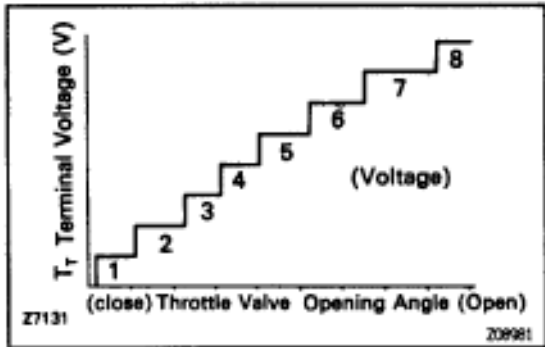
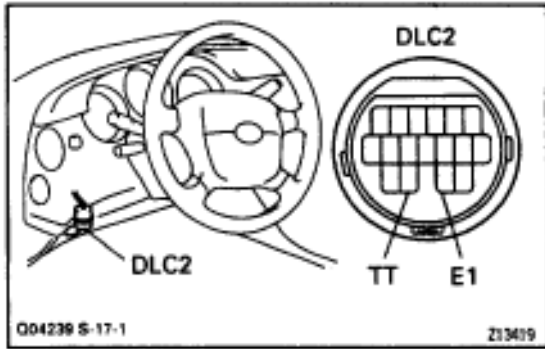

CHECK TERMINAL TT OUTPUT VOLTAGE

When a voltmeter is connected to the DLC2, the following items can be checked:

1. Throttle position sensor signal
2. Brake signal
3. Shift position signal

1. VOLTMETER CONNECTION

Connect the positive (+) probe of the voltmeter to terminal TT and the negative (-) probe to terminal E1 of the DLC2.

HINT: If a voltmeter with small internal resistance is used, the correct voltage will not be indicated, so use a voltmeter with an internal resistance of at least 10 k Ω /V.

2. TURN IGNITION SWITCH TO ON (DO NOT START THE ENGINE)

3. CHECK THROTTLE POSITION SENSOR SIGNAL

Check if the voltage changes from approx. 0 V to approx. 8 V when the accelerator pedal is gradually depressed from the fully closed position.

4. CHECK BRAKE SIGNAL (LOCK-UP CUT SIGNAL)

- (a) Open the throttle valve fully to apply approx. 8 V to terminal TT.
- (b) In this condition, check terminal TT voltage when the brake pedal is depressed and released.

TT terminal voltage:

0 V (When brake pedal is depressed)

8 V (When brake pedal is released)

5. START ENGINE

6. CHECK SHIFT POSITION SIGNAL

(VEHICLE SPEED ABOVE 9 km/h, 6 mph)

Check up-shifting together with terminal TT voltage.

HINT: Check for light shocks from up-shifting and for changes in the tachometer.

Gear Position	Terminal TT output voltage
1st Gear	0 V
2nd Gear	2 V
2nd Lock-up	3 V
3rd Gear	4 V
3rd Lock-up	5 V
O/D	6 V
O/D Lock-up	7 V

If terminal TT output voltage check cannot be done, do the check of TT terminal circuit on page [AT1-95](#).

PROBLEM SYMPTOM CONFIRMATION

Taking into consideration the results of the customer problem analysis, try to reproduce the symptoms of the trouble. If the problem is that the transmission does not up-shift, does not down-shift, or the shift point is too high or too low, conduct the following road test to confirm the automatic shift schedule and simulate the problem symptoms.

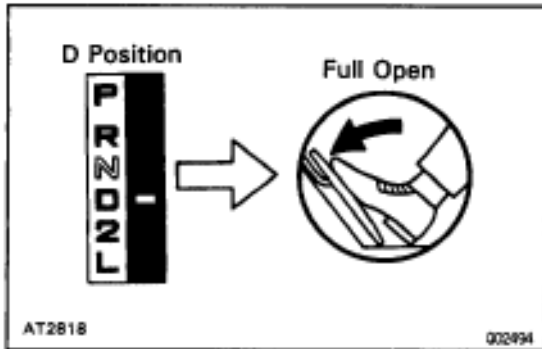

ROAD TEST

NOTICE: Do the test at normal A/T fluid operating temp. 50–80°C (122 – 176°F).

1. D POSITION TEST (NORM PATTERN)

Shift into the D position and keep the accelerator pedal constant at the full throttle valve opening position, and check the following points:

(a) Check up-shift operation.

Check that 1–2, 2–3 and 3–O/D up-shift takes place, at the shift point shown in the automatic shift schedule.

(See page [AT1-96](#))

HINT:

(1) O/D Gear Up-shift Prohibition Control.

- Coolant temp. is 60°C (140°F) or less.
- If there is a 10 km/h (6 mph) difference between the set cruise control speed and
- vehicle speed.
- O/D main switch is pushed ON.
- (During O/D OFF, indicator light lights up.)

(2) O/D Gear Lock-up Prohibition Control.

- Brake pedal is depressed.
- Coolant temp. is 60°C (140°F) or less.

(b) Check for shift shock and slip.

Check for shock and slip at the 1–2, 2–3 and 3–O/ D up-shifts.

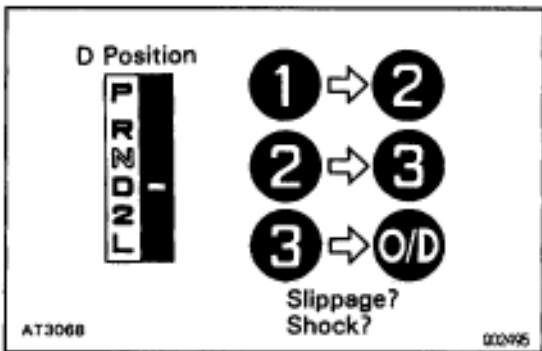

(c) Check for abnormal noise and vibration.

Run at the D position lock-up or O/D gear and check for abnormal noise and vibration.

HINT: The check for the cause of abnormal noise and vibration must be performed very thoroughly as it could also be due to loss of balance in the torque converter clutch, etc.

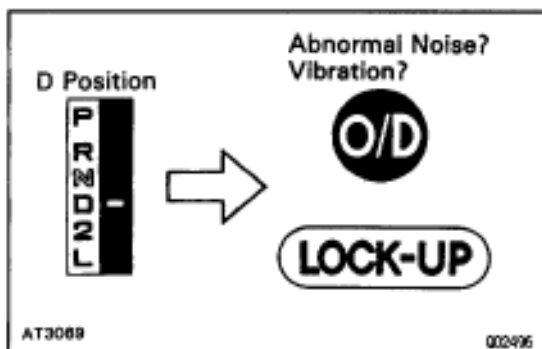

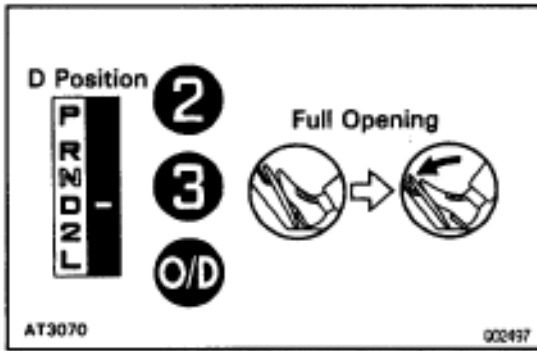

- (d). Check kick-down operation.
While running in the D position, 2nd, 3rd and O/D gears, check to see that the possible kick-down vehicle speed limits for 2 → 1, 3 → 2 and O/D → 3 kick-downs conform to those indicated on the automatic shift schedule. (See page [AT1-96](#))
- (e) Check for abnormal shock and slip at kick-down.

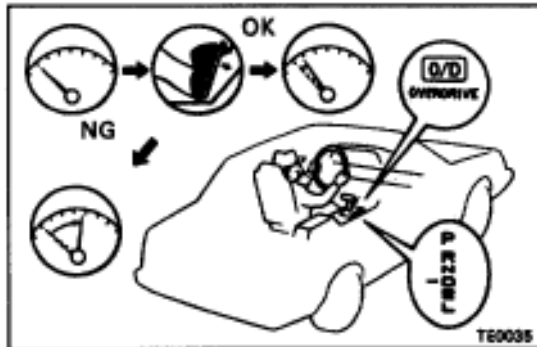

- (f) Check the lock-up mechanism.
(1) Drive in D position, O/D gear, at a steady speed (lock-up ON) of about 61 km/h (38 mph).
(2) Lightly depress the accelerator pedal and check that the RPM does not change abruptly.
If there is a big jump in RPM, there is no lock-up.

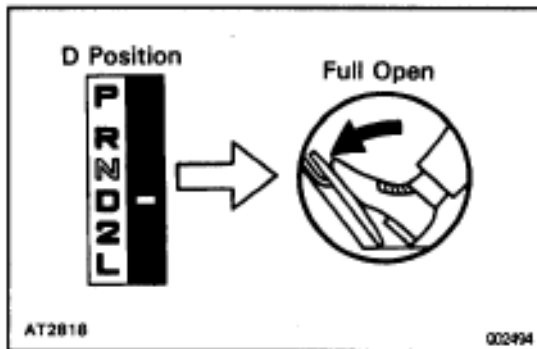

2. D POSITION TEST (MANU PATTERN)

Shift into the D position and hold the accelerator pedal constant at the full throttle valve opening position, and check the following points:

- (a) Check up-shift operation.
2-3 and 3-O/D up shifts should take place, and shift points should conform to those shown in the automatic shift schedule.

(See page [AT1-96](#))

HINT:

- O/D up-shift or lock-up will not occur when the engine coolant temp. is below 60°C (140°F) and speed is under 63 km/h (39 mph), or if there is a 10 km/h (6 mph) difference between the set cruise control speed.
- 3rd up-shift or lock-up will not occur when engine coolant temp. is 35°C (95°F) and speed is under 40 km/h (25 mph).

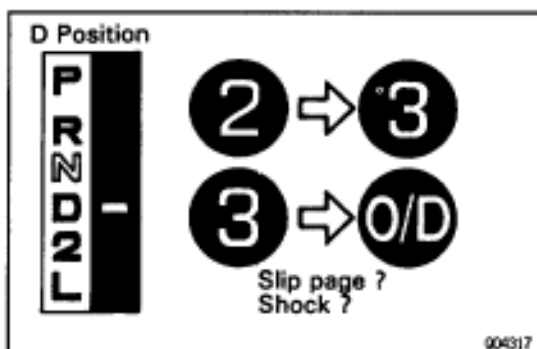

- (b) Check for shift shock and slip.
In the same manner, check the shock slip at the 2 → 3 and 3 → O/D up-shifts.

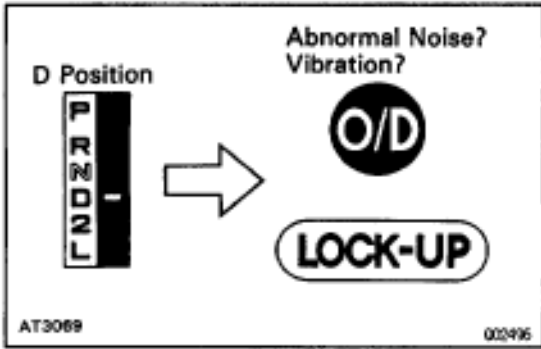

- (c) Check for abnormal noise and vibration.
Run at the D position lock-up or O/D gear and check for abnormal noise and vibration.
HINT: The check for the cause of abnormal noise and vibration must be made with extreme care as it could also be due to loss of balance in the propeller shaft, differential, torque converter clutch, etc.

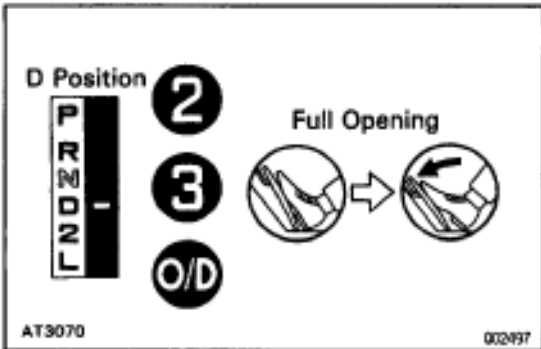

- (d) Check kick-down operation.
While running in the D position, 2nd, 3rd and O/D gears, check to see that the possible kick-down vehicle speed limits for 3 → 2 and O/D → 3 kick-downs conform to those indicated on the automatic shift schedule.
(See page AT1-96)
- (e) Check for abnormal shock slip at kick-down.

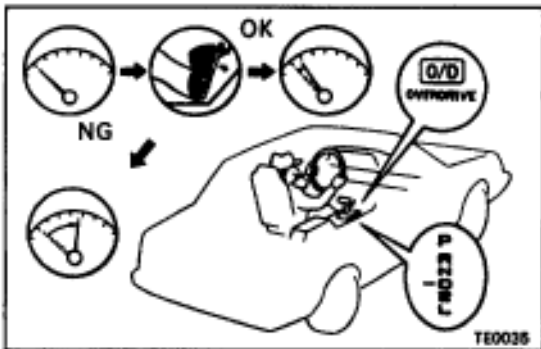

- (f) Check the lock-up mechanism.
(1) Drive in D position, O/D gear, at a steady speed (lock-up ON) of about 172 km/h (107 mph).
(2) Lightly depress the accelerator pedal and check that the engine RPM does not change abruptly.
If there is big jump in the engine RPM there is no lock-up.

3. 2 POSITION TEST (NORM PATTERN)

Shift into the 2 position and, while driving with the accelerator pedal held constantly at the full throttle valve opening position, check on the following points:

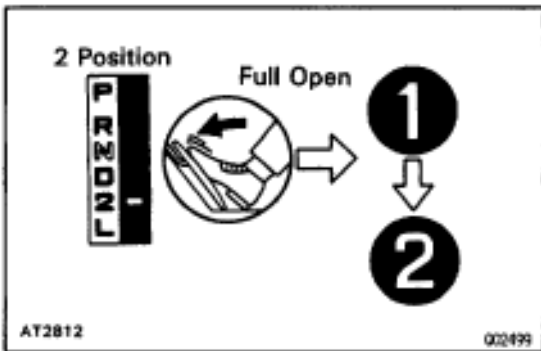

- (a) Check up-shift operation.
Check to see that the 1 → 2 up-shift takes place and that the shift point conforms to the automatic shift schedule.
(See page AT1-96)
HINT: There is no O/D up-shift and lock-up in the 2 position.

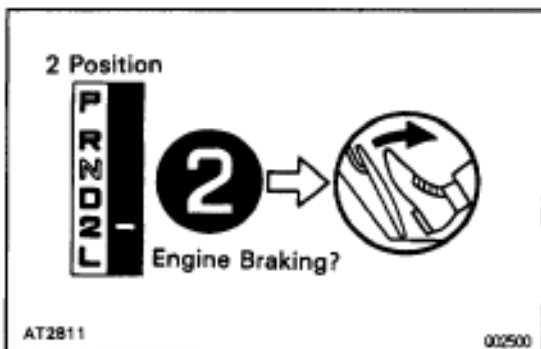

- (b) Check engine braking.
While running in the 2 position and 2nd gear, release the accelerator pedal and check the engine braking effect.

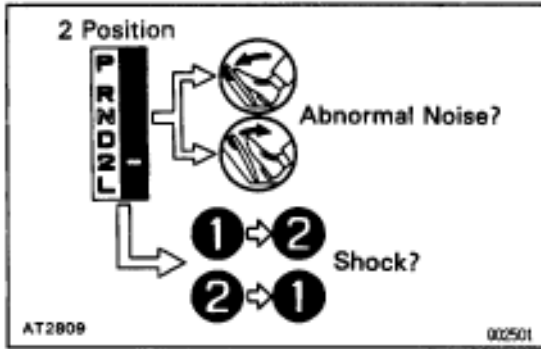

- (c) Check for abnormal noise at acceleration and deceleration, and for shock at up-shift and down-shift.

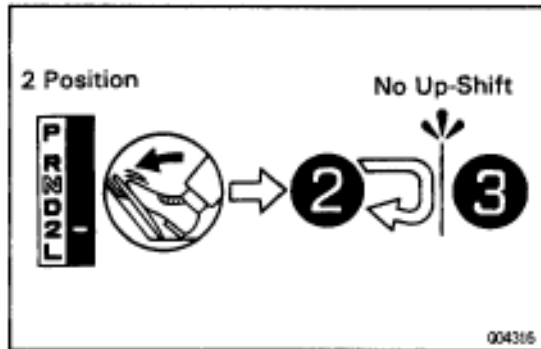

4. 2 POSITION TEST (MANU PATTERN)

Shift into the 2 position and while driving with the accelerator pedal held constantly at the full throttle valve opening position, push in one of the pattern selectors and check these points:

- (a) Check no up-shift.

While running in the 2 position, check to see that there is no up-shift to 3rd gear.

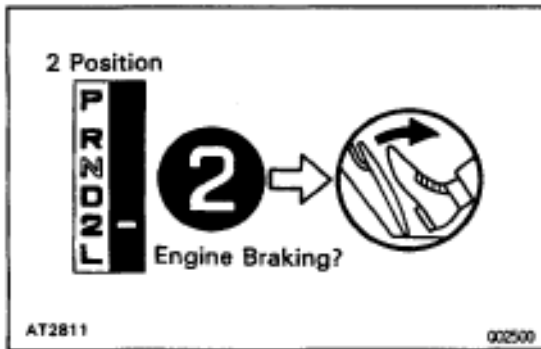

- (b) Check engine braking.

While running in the 2 position and 2nd gear, release the accelerator pedal and check the engine braking effect.

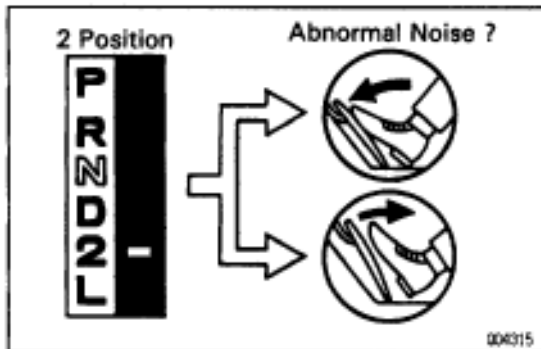

- (c) Check for abnormal noise during acceleration and deceleration.

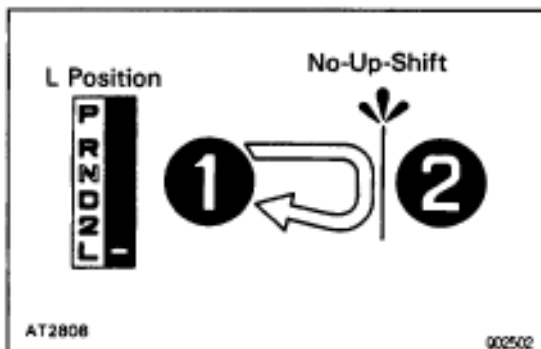

5. L POSITION TEST

Shift into the L position and while driving with the accelerator pedal held constantly at the full throttle valve opening position check the these points:

- (a) Check no up-shift.

While running in the L position, check that there is no up-shift to 2nd gear.

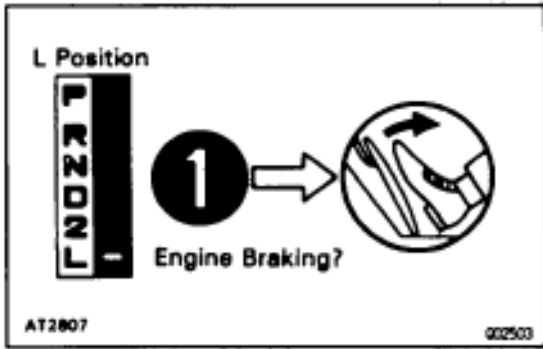

- (b) Check engine braking.
While running in the L position, release the accelerator pedal and check the engine braking effect.

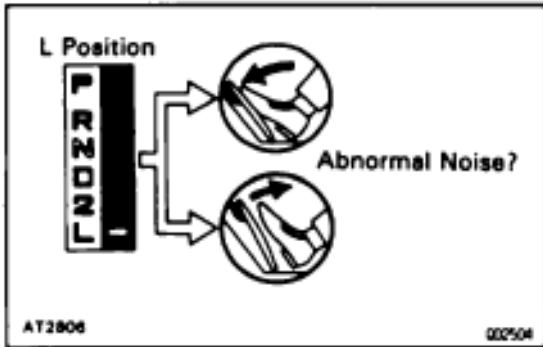

- (c) Check for abnormal noise during acceleration and deceleration.

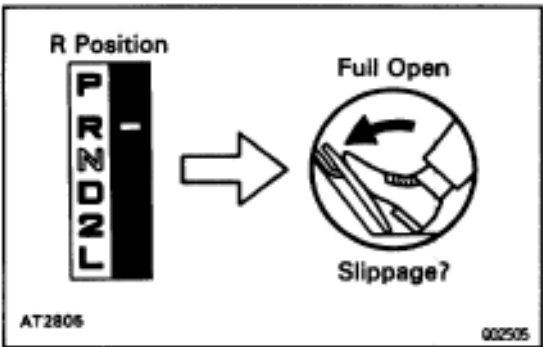

- 6. **R POSITION TEST**
Shift into the R position and while starting at full throttle, check for slippage.
CAUTION: Before conducting this test ensure that the test area is free from personnel and obstruction.

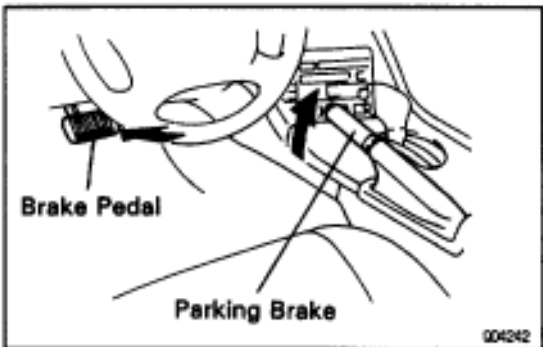

- 7. **P POSITION TEST**
Stop the vehicle on a gradient (more than 5°) and after shifting into the P position, release the parking brake. Then check to see that the parking lock pawl holds the vehicle in place.

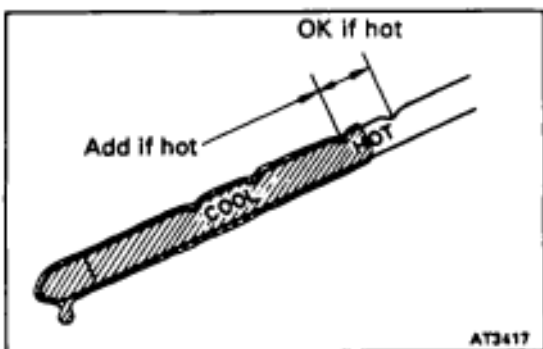
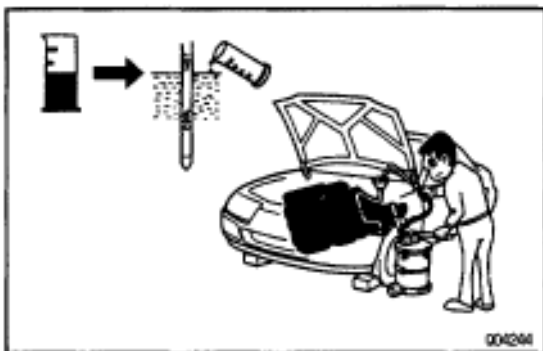
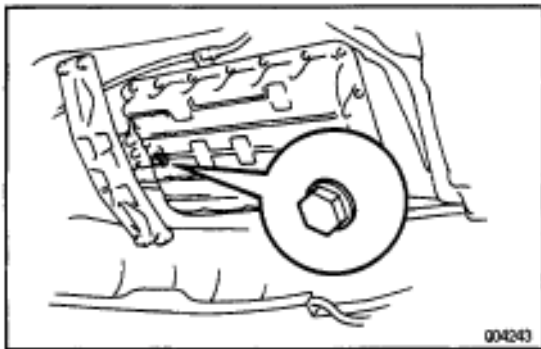
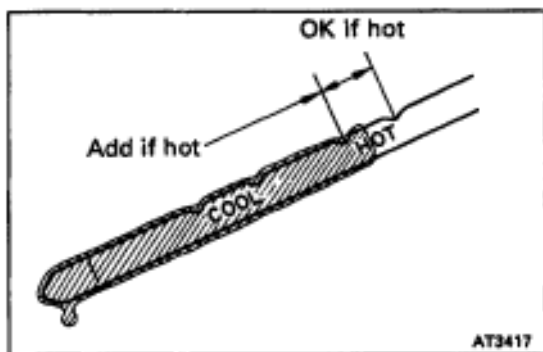
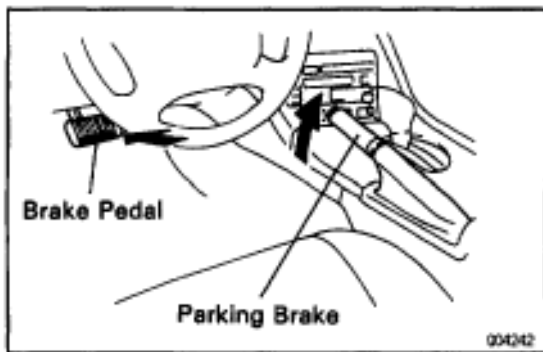

PRELIMINARY CHECK

1. CHECK FLUID LEVEL

HINT:

- Drive the vehicle so that the engine and transmission are at normal operating temp..
Fluid temp. 70–80 °C (158–176 °F)
- Only use the COOL range on the dipstick as a rough reference when the fluid is replaced or the engine does not run.

- Park the vehicle on a level surface and set the parking brake.
- With the engine idling and the brake pedal depressed, shift the shift lever into all positions from P to L position and return to P position.
- Pull out the transmission dipstick and wipe it clean.
- Push it back fully into the pipe.
- Pull it out and check that the fluid level is in the HOT range. If the level is at the low side, add fluid.

Fluid type:

DEXRON® II

NOTICE: Do not overfill.

2. CHECK FLUID CONDITION

If the fluid smells burnt or is black, replace it.

3. REPLACE TRANSMISSION FLUID

- Remove the drain plug and drain the fluid.
- Reinstall the drain plug securely.
- With the engine OFF, add new fluid through the oil filler pipe.

Fluid type:

DEXRON® II

Capacity:

Dry fill: 7.2 liters (7.6 US qts, 6.3 Imp. qts)

Drain and refill: 1.6 liters (1.7 US qts, 1.4 Imp. qts)

- Start the engine and shift the shift lever into all positions from P to L position and then shift into P position.
- With the engine idling, check the fluid level. Add fluid up to the COOL level on the dipstick.
- Check the fluid level at the normal operating temperature 70–80 °C (158–176 °F) and add as necessary.

NOTICE: Do not overfill.

4. CHECK FLUID LEAKS

Check for leaks in the transmission.

If there are leaks, it is necessary to repair or replace O-rings, seal packings, oil seals, plugs or other parts.

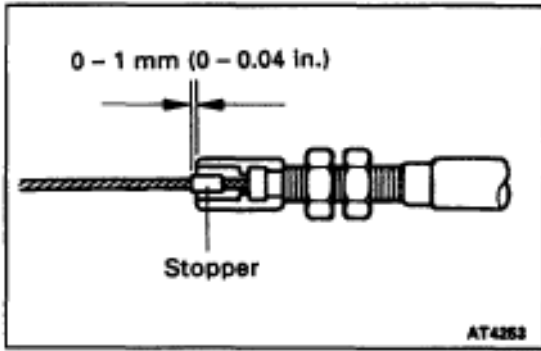

5. INSPECT AND ADJUST THROTTLE CABLE

- Check that the throttle valve is fully closed.
- Check that the inner cable is not slack.
- Measure the distance between the outer cable end and stopper on the cable.

Standard distance:

0-1 mm (0-0.04 in.)

If the distance is not standard, adjust the cable by the adjusting nuts.

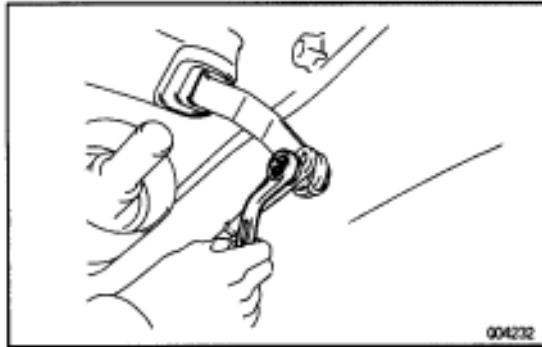

6. INSPECT AND ADJUST SHIFT LEVER POSITION

When shifting the shift lever from the N position to other positions, check that the lever can be shifted smoothly and accurately to each position and that the position indicator correctly indicates the position.

If the indicator is not aligned with the correct position, carry out the following adjustment procedures:

- Loosen the nut on the control shaft lever.
- Push the control shaft lever fully rearward.
- Return the control shaft lever 2 notches to N position.
- Set the shift lever to N position.
- While holding the shift lever lightly toward the R position side, tighten the shift lever nut.
- Start the engine and make sure that the vehicle moves forward when shifting the lever from the N to D position and reverses when shifting it to the R position.

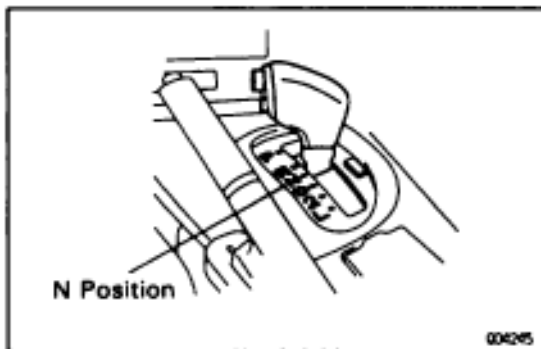
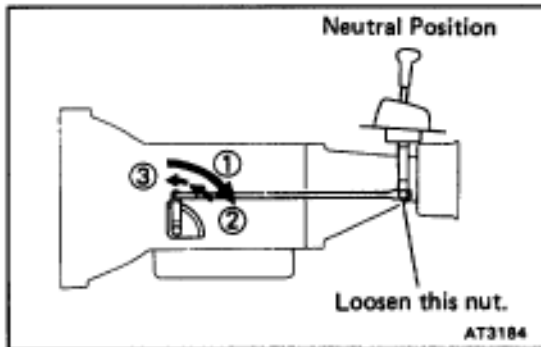

7. INSPECT AND ADJUST PARK/NEUTRAL POSITION SWITCH

Check that the engine can be started with the shift lever only in the N or P position, but not in other positions.

If not as started above, carry out these adjustment procedures:

- Loosen the park/neutral position switch bolt and set the shift lever to the N position.

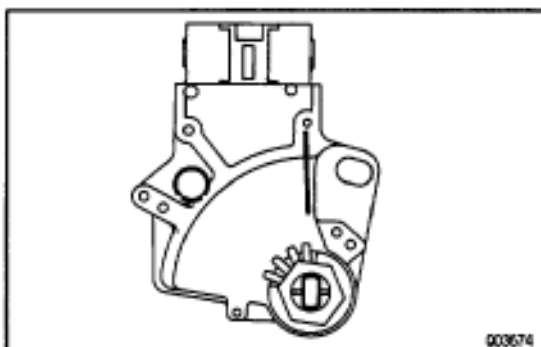

- Align the groove and neutral basic line.
- Hold in position and tighten the bolt.

Torque: 13 N·m (130 kgf·cm, 9 ft·lbf)

For continuity inspection of the park/neutral position switch, see page [AT1-81](#).

8. INSPECT IDLE SPEED

Idle speed:

700 ± 50 rpm

(In N position and air conditioner OFF)

MECHANICAL SYSTEM TEST

STALL TEST

The object of this test is to check the overall performance of the transmission and engine by measuring the stall speeds in the D and R positions.

NOTICE:

- Do the test at normal operating fluid temp. 50–80 °C (122–176 °F).
- Do not continuously run this test longer than 5 seconds.
- To ensure safety, conduct this test in a wide, clear, level area which provides good traction.
- The stall test should always be carried out in pairs. One technician should observe the conditions of wheels or wheel stoppers outside the vehicle while the other is doing the test.

MEASURE STALL SPEED

- Chock the 4 wheels.
- Connect a tachometer to the engine.
- Fully apply the parking brake.
- Keep your left foot pressed firmly on the brake pedal.
- Start the engine.
- Shift into the D position. Fully depress the accelerator pedal with your right foot. Quickly read the stall speed.

Stall speed:

$2,450 \pm 150$ rpm

- Do the same test in R position. Quickly read the stall speed.

Stall speed:

$2,450 \pm 150$ rpm

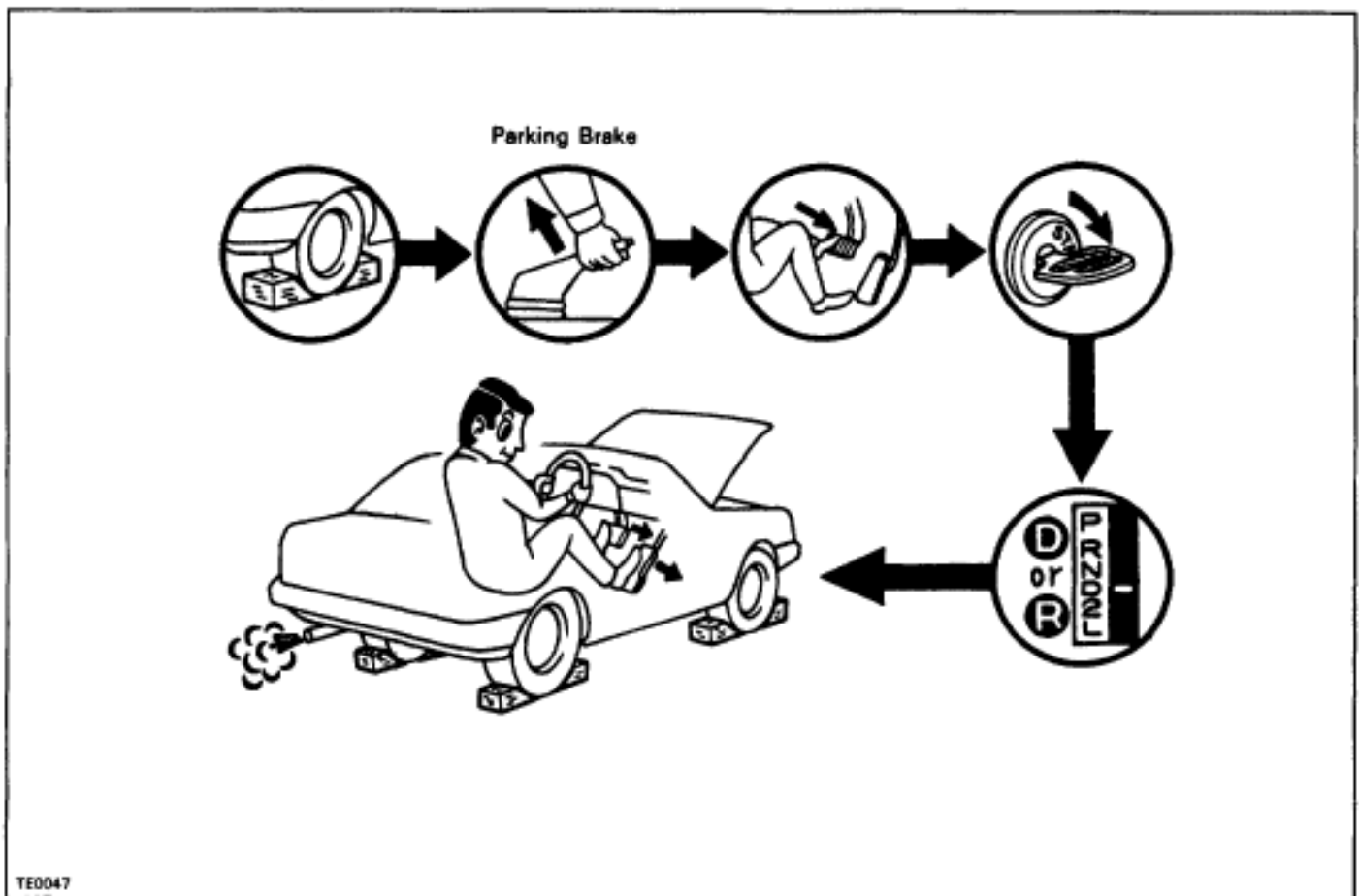

EVALUATION

Problem	Possible cause
(a) Stall speed low in D and R positions.	<ul style="list-style-type: none"> ● Engine output may be insufficient. ● Stator one-way clutch is operating properly HINT: If more than 600 rpm below the specified value, the torque converter clutch could be faulty.
(b) Stall speed high in D position.	<ul style="list-style-type: none"> ● Line pressure too low ● Forward clutch slipping ● No.2 one-way clutch not operating properly ● O/D one-way clutch not operating properly
(c) Stall speed high in R position.	<ul style="list-style-type: none"> ● Line pressure too low ● Direct clutch slipping ● First and reverse brake slipping ● O/D clutch one-way clutch not operating properly
(d) Stall speed high in D and R positions.	<ul style="list-style-type: none"> ● Line pressure too low ● Improper fluid level ● O/D one-way clutch not operating properly

TIME LAG TEST

When the shift lever is shifted while the engine is idling, there will be a certain time lapse or lag before the shock can be felt. This is used for checking the condition of the O/D direct clutch, forward clutch, direct clutch, and first and reverse brake.

NOTICE:

- Do the test at normal operating fluid temp. 50–80 °C (122–176 °F).
- Be sure to allow a one minute interval between tests.
- Take 3 measurements and take the average value.

MEASURE TIME LAG

- Fully apply the parking brake
- Start the engine and check idle speed.

Idle speed:

700 ± 50 rpm (In N position and air conditioner OFF)

- Shift the shift lever from N to D position. Using a stop watch, measure the time it takes from shifting the lever until the shock is felt.

In same manner, measure the time lag for N → R.

Time lag:

N → D Less than 1.2 seconds

N → R Less than 1.5 seconds

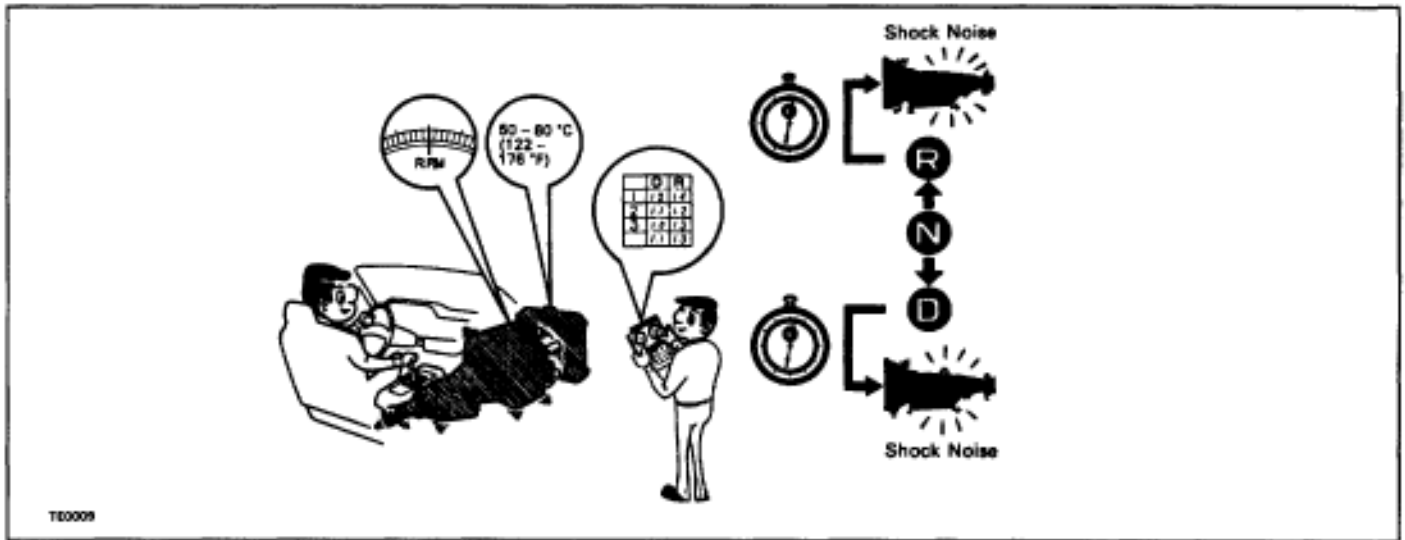

EVALUATION

If N → D or N → R time lag is longer than specified:

Problem	Possible cause
N→D time lag is longer	<ul style="list-style-type: none">· Line pressure too low· Forward clutch worn· O/D one-way clutch not operating properly· Accumulator back pressure too low
N→R time lag is longer	<ul style="list-style-type: none">· Line pressure too low· Direct clutch worn· First and reverse brake worn· O/D clutch one-way clutch not operating properly· Accumulator back pressure too low

HYDRAULIC TEST

MEASURE LINE PRESSURE

NOTICE:

- Do the test at normal operating fluid temp. 50–80 °C (122–176 °F).
- The line pressure test should always be carried out in pairs. One technician should observe the conditions of wheels or wheel stoppers outside the vehicle while the other is doing the test.
- Be careful to prevent the oil pressure gauge hose from interfering with the exhaust pipe.

- (a) Warm up the transmission fluid.
- (b) Remove the test plug on the transmission case left side and connect the oil pressure gauge (SST). SST 09992-00094 (Oil pressure gauge)

HINT: Connecting the oil pressure gauge will be made easier by moving LH side heat insulator aside.

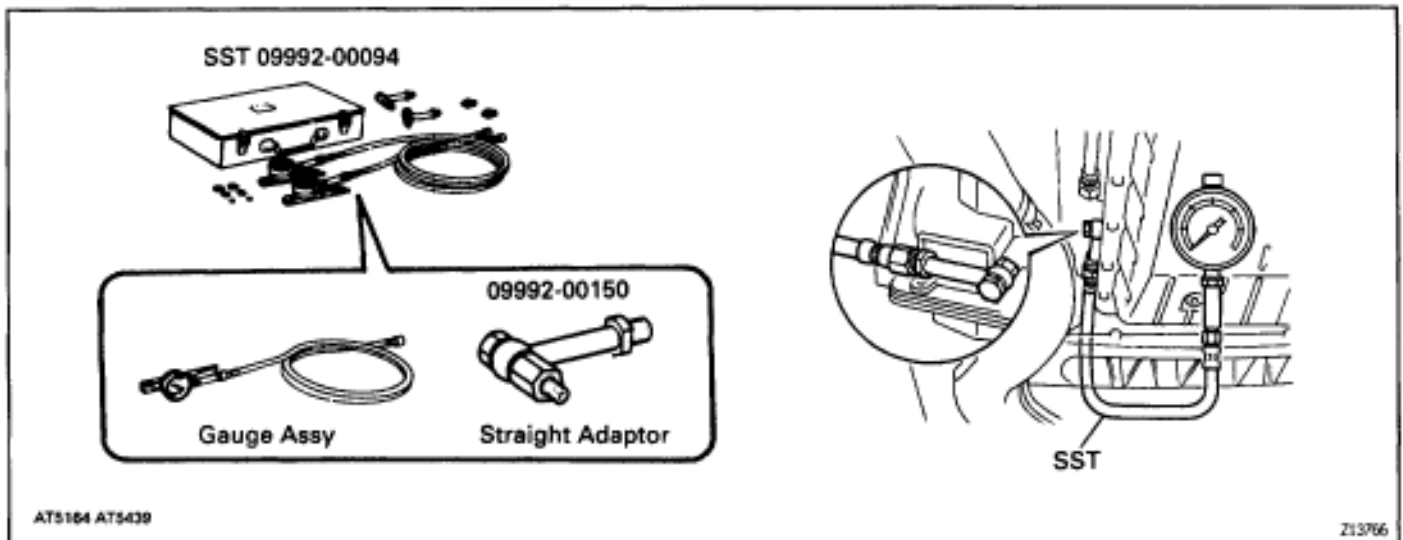

- (c) Fully apply the parking brake and chock the 4 wheels.
- (d) Start the engine and check idling RPM.
- (e) Keep your left foot pressed firmly on the brake pedal and shift into D position.
- (f) Measure the line pressure when the engine is idling.
- (g) Press the accelerator pedal all the way down. Quickly read the highest line pressure when engine speed reaches stall speed.
- (h) In the same manner, do the test in R position.

SPECIFIED LINE PRESSURE

Line pressure	D position kPa (kgf/cm ² ,psi)	R position kPa (kgf/cm ² , psi)
Idling	363-422 (3.7-4.3, 53-61)	500-598 (5.1-6.1, 73-88)
Stall	902-1,147 (9.2-11.7, 131-166)	1,236-1,589 (12.6-16.2, 179-230)

If the measured pressures are not up to specified values, recheck the throttle cable adjustment and retest.

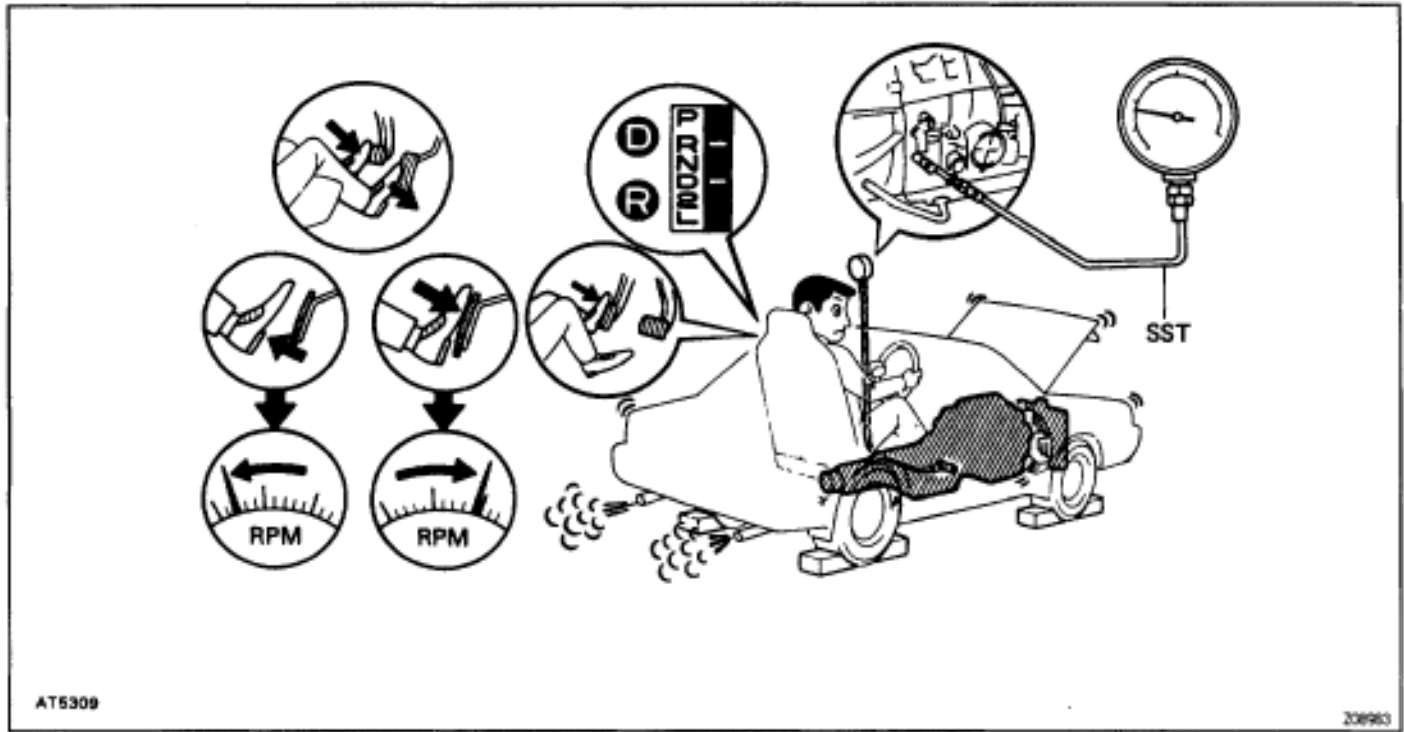

EVALUATION

Problem	Possible cause
If the measured values at all positions are higher.	<ul style="list-style-type: none"> · Throttle cable out of adjustment · Throttle valve defective · Regulator valve defective
If the measured values at all positions are lower.	<ul style="list-style-type: none"> · Throttle cable out of adjustment · Throttle valve defective · Regulator valve defective · Oil pump defective · O/D direct clutch defective
If pressure is low in the D position only.	<ul style="list-style-type: none"> · D position circuit fluid leakage · Forward clutch defective
If pressure is low in the R position only	<ul style="list-style-type: none"> · R position circuit fluid leakage · Direct clutch defective · First and reverse brake defective

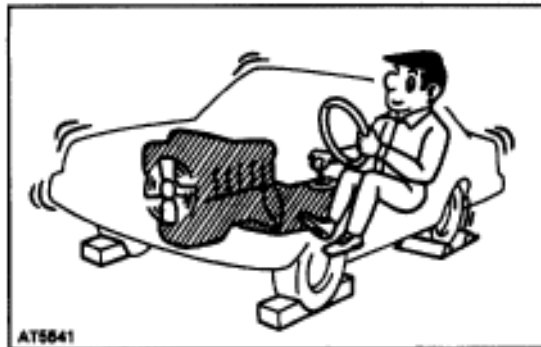
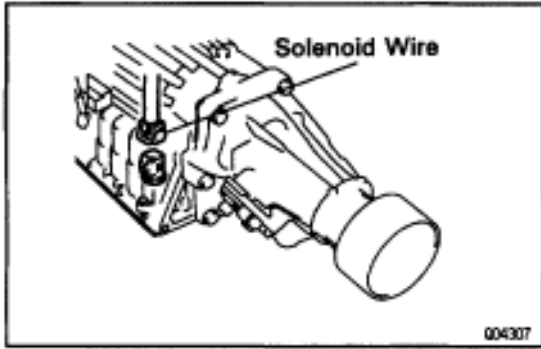

MANUAL SHIFTING TEST

HINT: With this test, it can be determined whether the trouble is within the electrical circuit or is a mechanical problem in the transmission.

1. DISCONNECT SOLENOID WIRE

2. INSPECT MANUAL DRIVING OPERATION

Check that the shift and gear positions correspond with the table below.

Shift Position	Gear Position
D	O/D
2	3rd
L	1st
R	Reverse
P	Pawl Lock

HINT: If the L, 2 and D position gear positions are difficult to distinguish, do the following road test.

- While driving, shift through the L, 2 and D positions. Check that the gear change corresponds to the shift position.

If any abnormality is found in the above test, the problem is in the transmission itself.

3. CONNECT SOLENOID WIRE





4. CANCEL OUT DIAGNOSTIC TROUBLE CODE

(See page [AT1-35](#))

-Memo-

DIAGNOSTIC TROUBLE CODE CHART

If a diagnostic trouble code is displayed during the diagnostic trouble code check, check the circuit listed for that code in the table below and proceed to the page given.

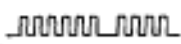
DTC No.	Blinking Pattern	Circuit	Diagnostic Trouble Code Detection Condition
38	 062818	A/T fluid temp. sensor	Either (a) or (b) are detected for 0.5 sec. or more. (a) Temperature sensor resistance less than 79 Ω (b) After the engine has been operating for 15 minutes or more, the resistance at the temperature sensor is more than 156 k Ω
42	 0E3034	No. 1 vehicle speed sensor	All conditions below are detected 500 times or more continuously. (2 trip detection logic) *3 (a) No No. 1 vehicle speed sensor signal in 16 pulses of No. 2 vehicle speed sensor signal. (b) Vehicle speed: 9 km/h (5.6 mph) or more for 4 secs. or more. (c) Park/neutral position switch: OFF (Other than P or N position)
61	 0E3036	No. 2 vehicle speed sensor	All conditions below are detected 500 times or more continuously. (2 trip detection logic) *3 (a) No No. 2 vehicle speed sensor signal in 4 pulses of No. 1 vehicle speed sensor signal. (b) Vehicle speed: 9 km/h (5.6 mph) or more for 4 secs. or more. (c) Park/neutral position switch: OFF (Other than P or N position)
62	 0E3038	No. 1 solenoid valve	(1) Solenoid resistance of 8 Ω or less is detected (*) 8 times or more when No. 1 solenoid is energized. (2) Solenoid resistance of 100 k Ω or more is detected (*) 8 times or more when No. 1 solenoid is not energized. (*) If the above failures are detected less than 8 times, the ECM memorizes the malfunction code but the O/D OFF indicator light does not blink.
63	 0E3036	No. 2 solenoid valve	(1) Solenoid resistance of 8 Ω or less is detected (*) 8 times or more when No. 2 solenoid is energized. (2) Solenoid resistance of 100 k Ω or more is detected (*) 8 times or more when No. 2 solenoid is not energized. (*) If the above failures are detected less than 8 times, the ECM memorizes the malfunction code but the O/D OFF indicator light does not blink.
64	 0E3036	Lock-up solenoid valve	(a) Solenoid resistance is 8 Ω or lower (short circuit) when solenoid energized. (b) Solenoid resistance is 100 k Ω or higher (open circuit) when solenoid is not energized. (*) ECM memorizes diag. trouble code 64 if above (a) or (b) condition is detected once or more, but ECM does not start O/D OFF indicator light blinking.

Trouble Area	O/D OFF Light *1 Blinks	Memory *2	See Page
<ul style="list-style-type: none"> • Harness or connector between A/T fluid temp. sender and ECM. • A/T fluid temp. sensor. • ECM 	○	○	AT1-64
<ul style="list-style-type: none"> • Harness or connector between No. 1 vehicle speed sensor and ECM. • No. 1 vehicle speed sensor. • Telltale light RH. • ECM 	○	○	AT1-66
<ul style="list-style-type: none"> • Harness or connector between No. 2 vehicle speed sensor and ECM. • No. 2 vehicle speed sensor. • ECM 	○	○	AT1-69
<ul style="list-style-type: none"> • Harness or connector between No. 1 solenoid and ECM. • No. 1 solenoid valve. • ECM 	○	○	AT1-72
<ul style="list-style-type: none"> • Harness or connector between No. 2 solenoid and ECM. • No. 2 solenoid valve. • ECM 	○	○	AT1-72
<ul style="list-style-type: none"> • Harness or connector between lock-up solenoid and ECM. • Lock-up solenoid valve. • ECM 	×	○	AT1-75

- *1 "○" mark means "O/D OFF" indicator light blinks once every 2 seconds.
"X" mark means "O/D OFF" indicator light never blinks.
- *2 "○" marks means the ECM memorizes the malfunction code if the ECM detects the diagnostic trouble code detection condition.
- *3 This indicates items for which "2 trip detection logic" is used. With this logic, when a logic malfunction is first detected, the malfunction is temporarily stored in the ECM memory. If the same case is detected again during the second drive test, this second detection causes the O/D OFF Indicator Light to blink. The 2 trip repeats the same mode twice. (However, the IG switch must be turned OFF between the 1st trip and 2nd trip.)

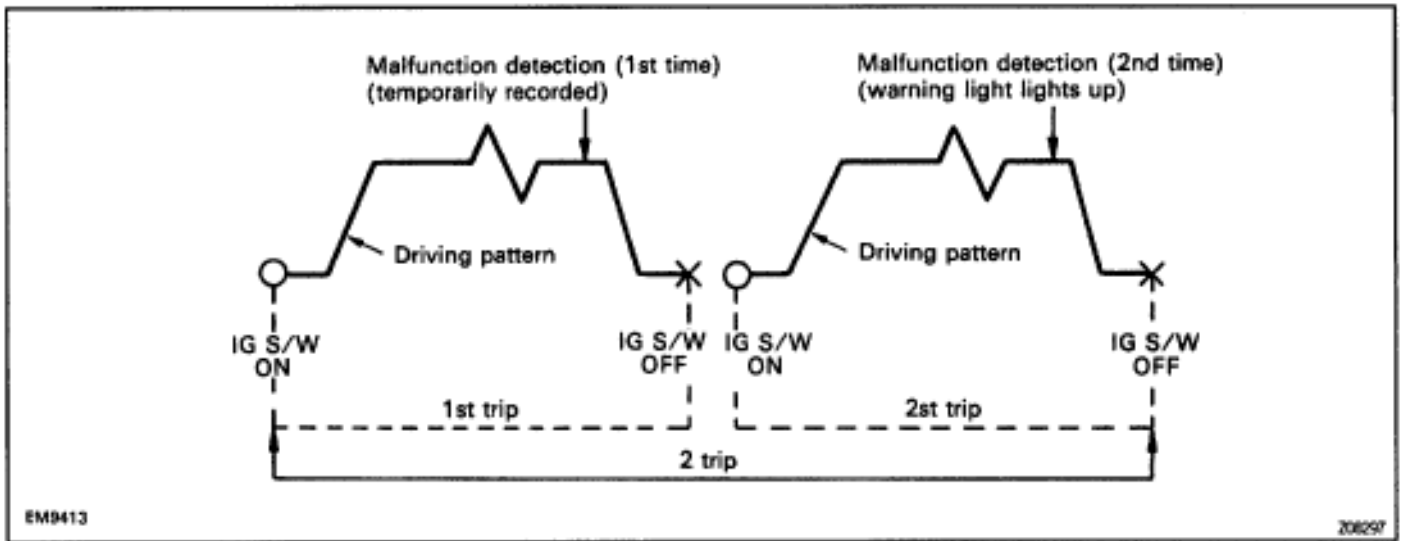

HINT:

- If the malfunction returns to normal while a malfunction warning is being output, the O/D OFF indicator light stops blinking and goes off. However, the diagnostic trouble code is retained in memory until it is cleared from memory.
- If the diagnosis system outputs a diagnostic trouble code even though the O/D OFF indicator was not blinking, there is intermittent trouble. Check all the connections in the circuits corresponding to that code.
- If the vehicle speed sensors No.1 and No.2 happen to fail simultaneously, the ECM will neither alert the driver by blinking the O/D OFF indicator nor record any diagnostic trouble code. It will, however, decide that the vehicle can be driven only in 1st and none of the other gears, so shifting upward will then be prohibited.
- Codes 46, 62, 63 and 64 are limited to short or open circuits in the electrical system comprised of the solenoids, wire harnesses, and connectors. The ECM is unable to detect mechanical trouble (sticking, for example) in the solenoid valves.

-Memo-

STANDARD VALUE OF ECM TERMINAL

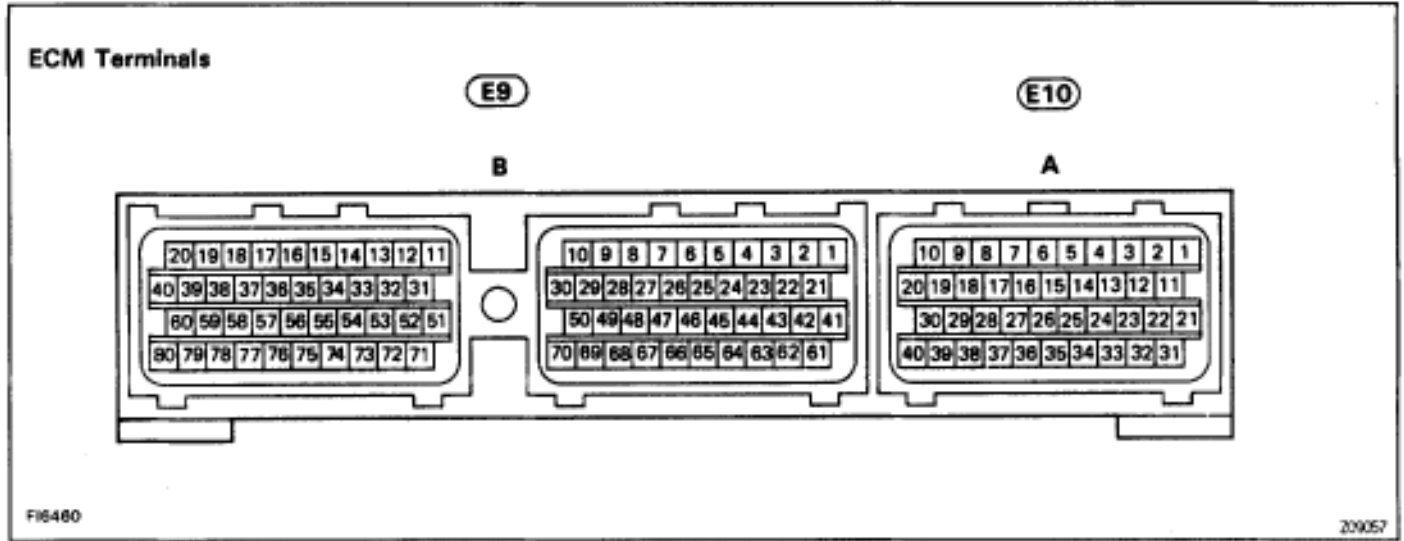

* A = (E10), B = (E9)

Terminals	Symbols	Wiring Color	Condition		Standard Value
B76 - B69	NSW - E1	B-W ↔ BR	IG ON	Shift Lever; P or N position	Below 3 V
				Shift Lever; Other than P or N position	9 - 14 V
B3 - B23	SP2 ⁻ - SP2 ⁺	G ↔ R	IG OFF		560 - 680 Ω
B10 - B69	S1 - E1	W-R ↔ BR	IG OFF		10 - 16 Ω
			Vehicle driving in 2nd gear position		9 - 14 Ω
			IG ON		9 - 14 Ω
B9 - B69	S2 - E1	RL ↔ BR	IG OFF		10 - 16 Ω
			Vehicle driving in 2nd or 3rd position		9 - 14 Ω
			IG ON		Below 1.5 V
B43 - B65	VTA1 - E2	Y ↔ BR-B	IG ON	Accel. pedal is not depressed	Below 0.8 V
				Accel. pedal is fully depressed	3.2 - 4.9 V
B64 - B65	IDL1 - E2	R ↔ BR-B	IG ON	Accel. pedal is not depressed	Below 3 V
				Accel. pedal is depressed	9 - 14 V
A2 - B65	SP1 - E2	P ↔ BR-B	Ignition switch ON Turn the rear wheel slowly		Repeat 0-8V or above
A3 - B69	KD - E1	Y ↔ BR	IG ON	Kick-down SW; OFF (Accel. pedal is not depressed)	9 - 14 V
				Kick-down SW; ON (Accel. pedal is fully depressed)	Below 3 V
A9 - B69	2 - E1	LG-R ↔ BR	IG ON	Shift Position; 2 position	7.5 - 14 V
				Shift Position; Other than 2 position	Below 1.5 V
A10 - B69	L - E1	G-B ↔ BR	IG ON	Shift Position; L position	7.5 - 14 V
				Shift Position; Other than L position	Below 1.5 V
A12 - B69	OD1 - E1	BR-B ↔ BR	Ignition switch ON		4.5 - 5.5 V
A18 - B69	M - E1	G-Y ↔ BR	IG ON	Pattern select SW: MANU	7.5 - 14 V
				Pattern select SW: NORM	Below 1.5 V
A28 - B69	OD2 - E1	V-G ↔ BR	IG ON	O/D main SW; ON	7.5 - 14 V
				O/D main SW; OFF	Below 3 V
B24 - B65	OIL - E2	BR-B ↔ O	A/T fluid temperature 110°C (230°F)		Below 1 V

MATRIX CHART OF PROBLEM SYMPTOMS

If a normal code is displayed during the diagnostic trouble code check but the trouble still occurs, check the circuits for each symptom in the order given in the charts on the following pages and proceed to the page given for troubleshooting.

The Matrix Chart is divided into 3 chapters.

Chapter 1: Electronic Circuit Matrix Chart

Chapter 2: On-vehicle Repair Matrix Chart

Chapter 3: Off-vehicle Repair Matrix Chart

When troubleshooting, check Chapter 1 first. If instructions are given in Chapter 1 to proceed to Chapter 2 or 3, proceed as instructed.

1. If the instruction "Proceed to next circuit inspection shown on matrix chart" is given in the flow chart for each circuit, proceed to the circuit with the next highest number in the table to continue the check.
2. If the trouble still occurs even though there are no abnormalities in any of the other circuits, then check or replace the ECM.

Chapter 1. Electronic Circuit

See Page		AT1-66	AT1-69	AT1-72	AT1-75	AT1-77	AT1-81	AT1-79
Suspect Area		No.1 Vehicle speed sensor circuit	No.2 Vehicle speed sensor circuit	No.1, No.2 Solenoid circuit	SL Solenoid circuit	Throttle position sensor circuit	Park/neutral position switch circuit	kick-down switch circuit
Symptom								
Vehicle does not move in any forward position and reverse position								
Vehicle does not move in particular position or positions								
No up-shift	1st → 2nd	3	4	1		2	6	
	2nd → 3rd	3	4	1		2	6	
	3rd → O/D	3	4	2		5	6	
No down-shift	O/D → 3rd	3	4	1		2		
	3rd → 2nd	3	4	1		2		
	2nd → 1st	3	4	1		2		
No lock-up		3	4		1	2	7	
No lock-up off		3	4		1	2		
Shift point too high or too low		3	4			1		
Up-shifts to 2nd while in L position Up-shifts to 3rd while in L position							1	
Up-shifts to O/D from 3rd while O/D switch is OFF								
Up-shifts to O/D from 3rd while engine is cold							3	
Harsh engagement	N → D				1	3	4	
	Lock-up	3	4		1	2		
	Any driving position	4	5		1	3		
Slip or Shudder	Forward and reverse							
	Any particular position							
No engine braking								
Poor acceleration		3	4		6	2		1
No kick-down		3		4		2		1
No pattern select*								
Large shift shock or engine stalls when starting off or stopping.					1			

* The automatic transmission is not shifted into the manual mode when the automatic transmission fluid temperature is too high.

	AT1-83	AT1-85	AT1-88	AT1-91	AT1-64	EG-312	AT1-56	AT1-60	AT1-62
Stop light switch circuit									
Pattern select switch circuit								1	2
O/D switch O/D OFF indicator light circuit								1	2
O/D cancel signal circuit							8	5	7
A/T fluid temp. sensor circuit							8	5	7
Engine coolant temp. switch circuit			1	7		8	11	9	10
ECM							8	5	-
On-Vehicle repair matrix chart							8	5	-
OFF-Vehicle repair matrix chart							7	5	6
	5					8	11	9	10
	5						8	6	7
		2					5	-	-
							2	-	-
			1				2	-	-
						1	4	2	3
					2		7	5	6
							7	5	6
					2		8	6	7
								1	2
								1	2
								1	2
							8	-	7
							6	5	-
		1					2	-	-
2							4	-	3

	★	★	★	★	★	★	★	★	★	★	★	★	★
	3-4 shift valve	Primary regulator valve	Lock-up relay valve	Accumulator control valve	Cut-back valve	C ₂ accumulator	Low coast modulator valve	B ₂ accumulator	2nd coast modulator valve	B ₀ accumulator	C ₀ accumulator	Pressure relief valve	OFF-Vehicle repair matrix chart
		4											6
													2
													1
													2
													2
1													2
1													2
													2
			2										3
				1									5
			2										4
				1		2							4
							1						
				1				3					
				1					3				
					1								
				2									
				1		3							4
				1						3			4
				1							3		4
												4	5
													3
							1						2
									1				2

AT1-62

Chapter 3. Off-Vehicle Repair

(★ : A340E, A340F, A340H AUTOMATIC TRANSMISSION Repair Manual Pub. No. RM391U)

See Page		★	★	★	★	★
Suspect Area		O/D one-way clutch (F ₀)	O/D brake (B ₀)	O/D direct clutch (C ₀)	O/D Planetary gear unit	Torque converter clutch
Symptom						1st reverse brake (B ₃)
Vehicle does not move in any forward position and reverse position		1	2	3	4	5
Vehicle does not move in R position				5		4
Vehicle does not move in:	D, 2 and L positions					
	D and 2 positions					
	2 position					1
	L position					
No up-shift	1st → 2nd					
	2nd → 3rd					
	3rd → O/D		1			
No down-shift	2nd → 1st					
No lock-up or No lock-up off						1
Harsh engagement	N → D					
	N → R					2
	2nd → 3rd					
	3rd → O/D		2	1	3	
	O/D → 3rd		1			
	Lock-up					1
Slip or Shudder	Forward & Reverse (After warm-up)	2		3		1
	Forward & Reverse (Just after engine starts)					1
	R position					2
	1st					
	2nd					
	3rd					
	O/D		1			
No engine braking	1st ~ 3rd			1		
	1st					1
	2nd					
Poor acceleration	All position					1
	O/D			1	2	
	Other than O/D		1			
	Other than 2nd					
	1st and 2nd					
	1st and R position					1
	R position					
Engine stalls when starting off or stopping						1

AT1-26

★	★	★	★	★	★	★
2nd coast brake (B ₁)	Direct clutch (C ₂)	Front and rear planetary gear unit	Forward clutch (C ₁)	No.2 one-way clutch (F ₂)	2nd brake (B ₂)	No.1 one-way clutch (F ₁)
1	3	2				
			1			
				1		
2	3				1	
					1	2
	1					
1					2	
			1			
1	1					
	1					
2			1	2		
	1				1	3
1						
1					2	
	1					
			1			

CIRCUIT INSPECTION

DTC 38 A T Fluid Temperature Sensor Circuit

CIRCUIT DESCRIPTION

The fluid temp. sensor converts fluid temp. into resistance values which is input into the ECM.

DTC No.	Diagnostic Trouble Code Detection Condition	Trouble Area
38	Either (a) or (b) are detected for 0.5 sec. or more (a) Temp. sensor resistance less than 79 Ω (b) After the engine has been operating for 15 minutes or more, the resistance at the temp. sensor is more than 156 kΩ	<ul style="list-style-type: none"> • Harness or connector between A/T fluid temp. sensor and ECM • A/T fluid temp. sensor • ECM

WIRING DIAGRAM

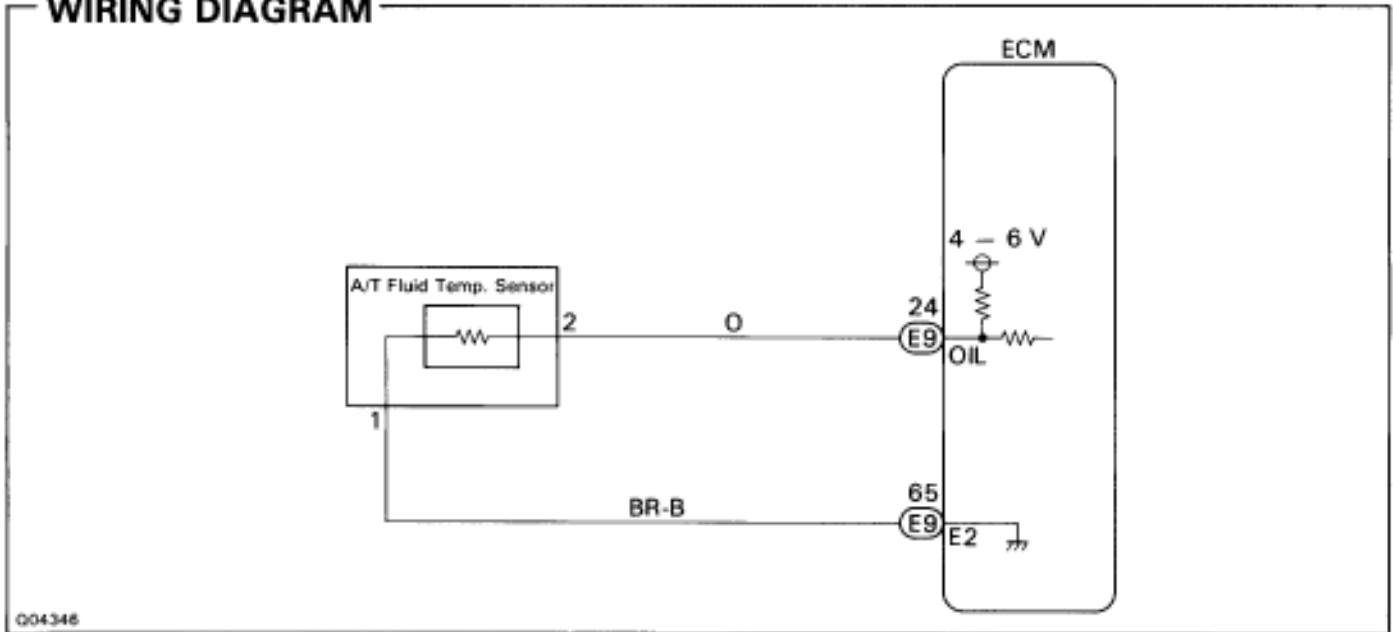

004348

INSPECTION PROCEDURE

1

Check A/T fluid temp. sensor.

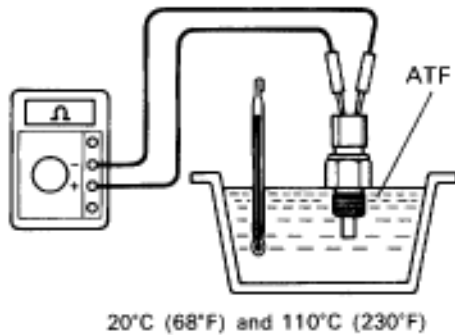

004314

OK

Check sensor resistance

- P** Remove A/T fluid temp. sensor.
- C** Measure resistance between terminals of A/T fluid temp. sensor at 20°C (68°F) and 110°C (230°F).
- OK** Resistance:

20°C (68°F)	Approx. 12.08 kΩ
110°C (230°F)	Approx. 0.78 kΩ

NG

Replace A/T fluid temp. sensor.

2

Check harness and connector between battery and A/T fluid temp. sensor A/T fluid temp. sensor and ECM. (See page [IN-30](#)).

OK

NG

Repair or replace harness or connector.

Check and replace ECM.

DTC 42 No. 1 Vehicle Speed Sensor Signal Circuit

CIRCUIT DESCRIPTION

The No. 1 vehicle speed sensor outputs a 4-pulse signal for every revolution of the rotor shaft, which is rotated by the transmission output shaft via the driven gear. After this signal is converted into a more precise rectangular waveform by the waveform shaping circuit inside the combination meter, it is then transmitted to the ECM. The ECM determines the vehicle speed based on the frequency of these pulse signals.

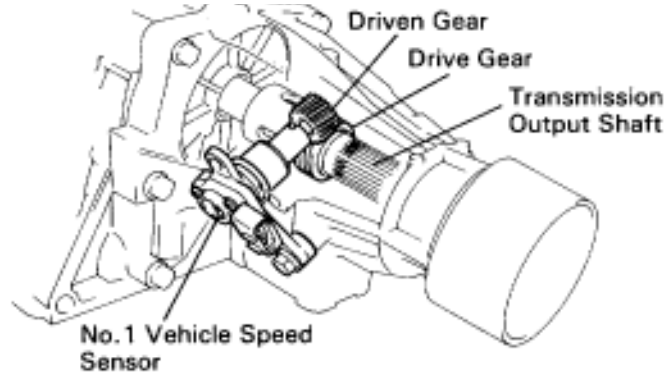
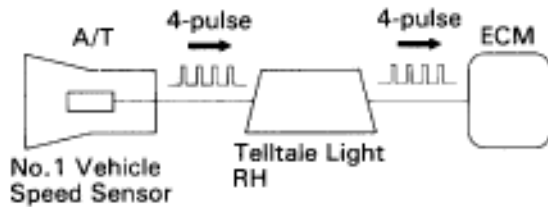

FI6643 FI6544

DTC No.	Diagnostic Trouble Code Detection Condition	Trouble Area
42	All conditions below are detected 500 times or more continuously. (2 trip detection logic)* (a) No. No. 1 vehicle speed sensor signal in 16 pulses of No. 2 vehicle speed sensor signal. (b) Vehicle speed: 9 km/h (5.6 mph) or more for 4 secs. or more for 4 secs. or more. (c) Park/neutral position switch: OFF (Other than P or N position)	<ul style="list-style-type: none"> • No. 1 vehicle speed sensor • Telltale light RH • Harness or connector between No. 1 vehicle speed sensor and ECM • ECM

*: See page AT1-54

HINT: In test more, diagnostic trouble code 42 is output when vehicle speed is 5 km/h (3 mph) or below.

< Reference >

- Waveform between terminals SP1 and E2 when vehicle speed is approx. 20 km/h (12 mph).

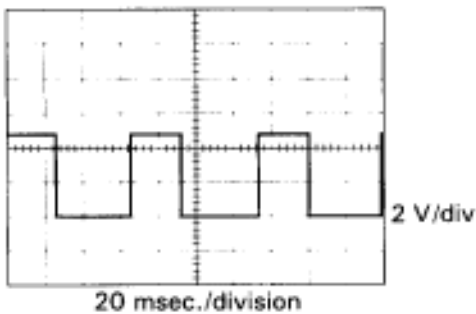

HINT: As the vehicle's speed increases, the signal output from SP1 increases.

V01496

WIRING DIAGRAM

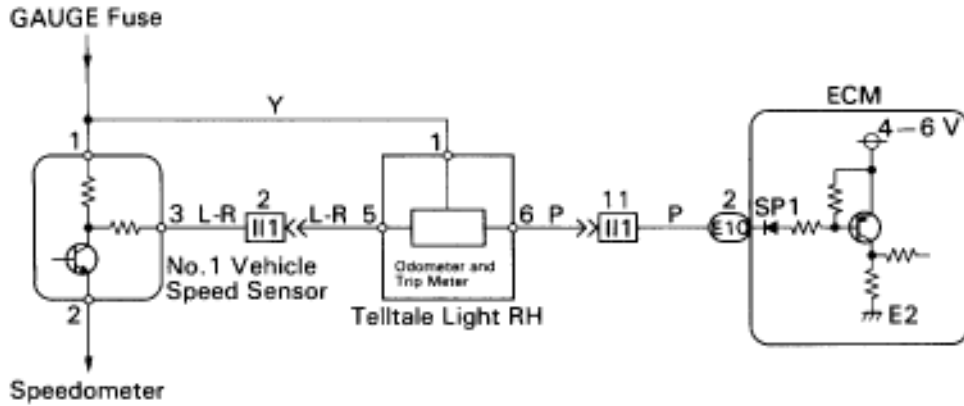

F16931

INSPECTION PROCEDURE

1

Check voltage between terminal SP1 of ECM connector and body ground.

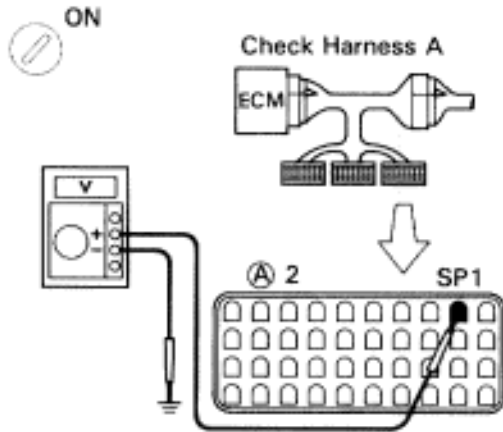

BE6653
F16504

P

- (1) Shift the shift lever to N position.
- (2) Jack up one of the rear wheels.
- (3) Connect the Check Harness A (See page EG-404)
- (4) Disconnect power steering ECU connector and cruise control ECU connector.
- (5) Turn ignition switch ON.

C

Measure voltage between terminal SP1 of ECM connector and body ground when the wheel is turned slowly.

OK

Voltage is generated intermittently.

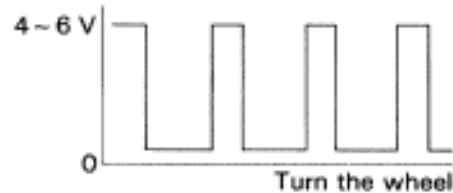

AT7809

NG

OK

Check and replace ECM.

2

Check operation of odometer and trip meter (telltale light RH (See page BR-48))

NG

OK

Repair or replace harness or connector between ECM and telltale light RH.

3**Check operation of No. 1 vehicle speed sensor (See page [BR-46](#)).****NG****OK**

Repair or replace harness or connector between tell-tale light RH and No. 1 vehicle speed sensor.

Replace No. 1 vehicle speed sensor.

DTC 61 No. 2 Vehicle Speed Sensor Circuit

CIRCUIT DESCRIPTION

The No. 2 vehicle speed sensor detects the rotation speed of the transmission output shaft and sends signals to the ECM. The ECM determines the vehicle speed based on these signals. An AC voltage is generated in the No.2 vehicle speed sensor coil as the rotor mounted on the output shaft rotates, and this voltage is sent to the ECM.

The gear shift point and lock-up timing are controlled by the ECM based on the signals from this vehicle speed sensor and the throttle position sensor signal.

If the No.2 vehicle speed sensor malfunctions, the ECM uses input signals from the No.1 vehicle speed sensor as a back-up signal.

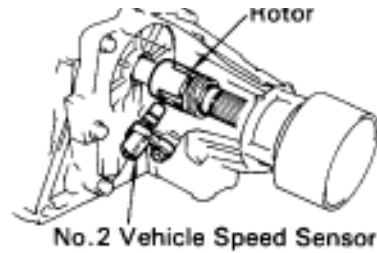
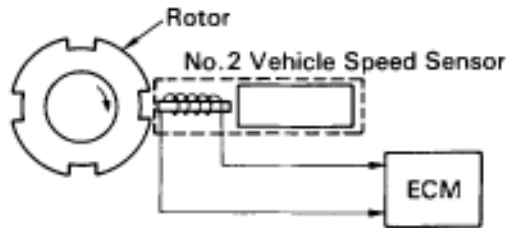

Q04436 Q04437

DTC No.	Diagnostic Trouble Code Detection Condition	Trouble Area
61	<p>All conditions below are detected 500 times or more continuously. (2 trip detection logic)*</p> <p>(a) No. 2 vehicle speed sensor signal in 4 pulses of No. 2 vehicle speed sensor signal.</p> <p>(b) Vehicle speed: 9 km/h (5.6 mph) or more for 4 secs. or more for 4 secs. or more.</p> <p>(c) Park/neutral position switch: OFF (Other than P or N position)</p>	<ul style="list-style-type: none"> No. 2 vehicle speed sensor Harness or connector between No. 2 vehicle speed sensor and ECM ECM

*: See page [AT1-54](#)

< Reference >

- Waveform between terminals SP2- and SP2- when vehicle speed is approx. 60 km/h (37 mph).

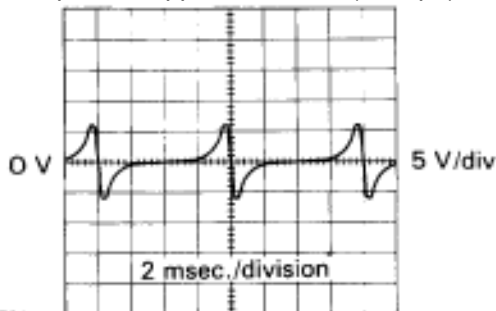

AT8761

WIRING DIAGRAM

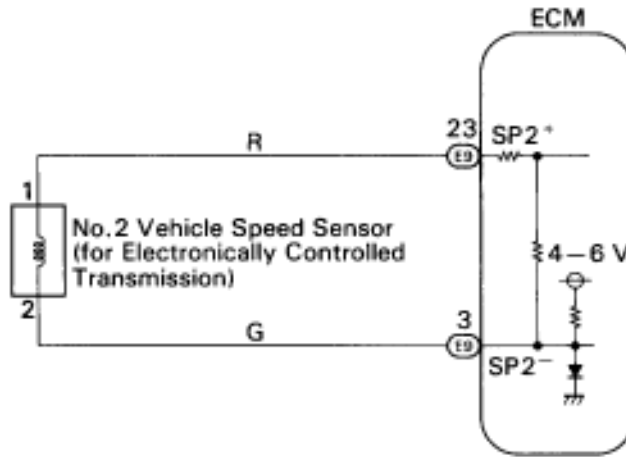

Q04348

INSPECTION PROCEDURE

1	Check resistance between terminals SP2+ and SP2- of ECM connector.
<p>LOCK</p> <p>BE3840 BE6653 AT8768</p>	<p>P Connect the Check Harness A to the ECM (See page EG-404).</p> <p>C Check resistance between terminals SP2+ and SP2- of ECM connector.</p> <p>OK Resistance: 560 – 680 Ω</p>
NG	OK Proceed to next circuit inspection shown on matrix chart (See page AT1-58).
<p>Go to 2 .</p>	

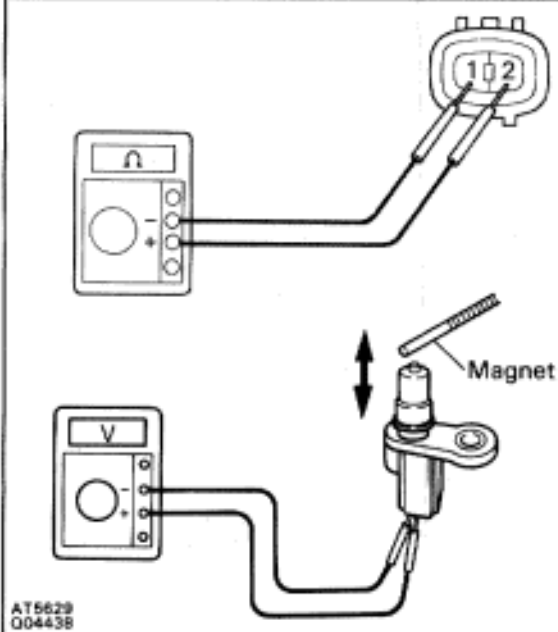
2**Check No. 2 vehicle speed sensor.**

- P** Remove No. 2 vehicle speed sensor from transmission (See page [AT1-14](#)).
- C** Measure resistance between terminals 1 and 2 of No. 2 vehicle speed sensor.
- OK** Resistance: 560 – 680 Ω

<Reference>

Check the vehicle speed sensor's function

- C** Check voltage between terminals 1 and 2 of the speed sensor when a magnet is put close to the front end of the vehicle speed sensor then taken away quickly.
- OK** Voltage is generated intermittently.
- Hint** The voltages generated is extremely low.

OK**NG**

Replace No. 2 vehicle speed sensor.

Check and repair harness and connector between ECM and No. 2 vehicle speed sensor (See page [IN-30](#)).

DTC 62 63 No.1 No. 2 Solenoid Valve Circuit

CIRCUIT DESCRIPTION

Shifting from 1st to O/D is done in combination with ON and OFF of the No.1 and No.2 solenoid valves controlled by ECM. If an open or short circuit occurs in either of the solenoid valves, the ECM controls the remaining normal solenoid to allow the vehicle to be operated smoothly (Fail safe function).

Fail Safe Function

If either of the solenoid valve circuits develops a short or an open, the ECM turns the other solenoid ON and OFF to shift to the gear positions shown in the table below. The ECM also turns the lock-up solenoid valve OFF at the same time. If both solenoids malfunction, hydraulic control cannot be performed electronically and must be done manually.

Manual shifting as shown in the following table must be done (In the case of a short circuit, the ECM stops sending current to the short circuited solenoid).

Position	NORMAL			NO.1 SOLENOID MALFUNCTIONING			NO.2 SOLENOID MALFUNCTIONING			BOTH SOLENOIDS MALFUNCTIONING
	Solenoid valve		Gear	Solenoid valve		Gear	Solenoid valve		Gear	Gear when shift selector is manually operated
	No.1	No.2		No.1	No.2		No.1	No.2		
D	ON	OFF	1st	X	ON	3rd	ON	X	1st	O/D
	ON	ON	2nd	X	ON	3rd	OFF	X	O/D	O/D
	OFF	ON	3rd	X	ON	3rd	OFF	X	O/D	O/D
	OFF	OFF	O/D	X	OFF	O/D	OFF	X	O/D	O/D
2	ON	OFF	1st	X	ON	3rd	ON	X	1st	3rd
	ON	ON	2nd	X	ON	3rd	OFF	X	3rd	3rd
	OFF	ON	3rd	X	ON	3rd	OFF	X	3rd	3rd
L	ON	OFF	1st	X	OFF	1st	ON	X	1st	1st
	ON	ON	2nd	X	ON	2nd	ON	X	1st	1st

X: Malfunctions

Check the No.1 solenoid when diagnostic trouble code 62 is output and check and No.2 solenoid when diagnostic trouble code 63 is output.

DTC No.	Diagnostic Trouble Code Detection Condition	Trouble Area
62, 63	<p>(a) Solenoid resistance is 8 Ω or lower (short circuit) when solenoid is energized.</p> <p>(b) Solenoid resistance is 100 kΩ or higher (open circuit) when solenoid is not energized.</p> <p>The ECM checks for an open or short circuit in the No.1 and No.2 solenoid circuit when it changes gear position.</p> <p>The ECM records diag. trouble code 62 or 63 if condition (a) or (b) is detected once, but it does not blink the O/D OFF indicator light.</p> <p>After the ECM detects the condition (a) or (b) continuously 8 times or more in one-trip *, it causes the O/D OFF indicator light to blink until condition (a) or (b) disappears.</p> <p>After that, if the ECM detects condition (a) or (b) one, it starts blinking the O/D OFF indicator light again.</p>	<ul style="list-style-type: none"> • Solenoid valve • Harness or connector between solenoid and • ECM • ECM

* one-trip (1st trip) See page [AT1-54](#)

WIRING DIAGRAM

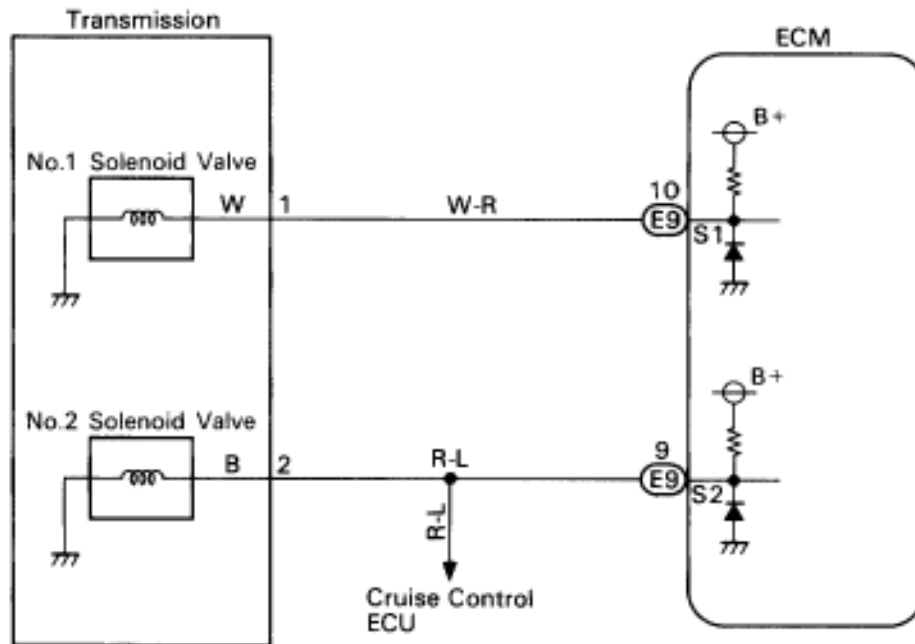

Q04349

INSPECTION PROCEDURE

1

Check No. 1, No. 2 solenoid valves.

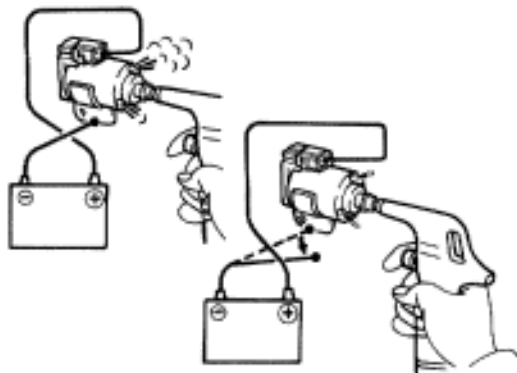
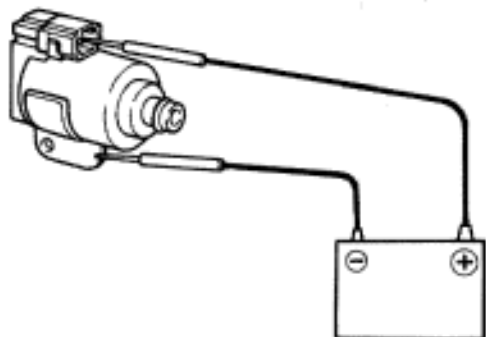
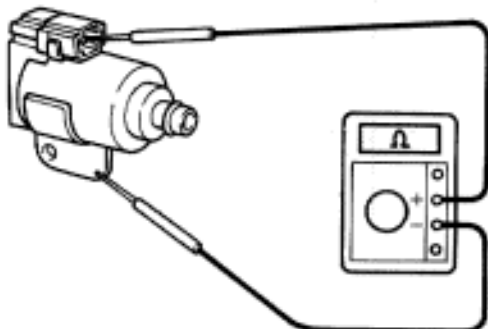

Q04439
Q04440
Q04441

Electrical Check

- P** 1. Jack up the vehicle.
2. Remove the oil pan.
3. Disconnect the solenoid connector.
- C** Measure resistance between solenoid connector and solenoid body.
- OK** Resistance: 10 – 16 Ω
- C** Connect positive (+) lead to terminal of solenoid connector, negative (-) lead to solenoid body.
- OK** The solenoid makes an operating noise.

Mechanical Check

- P** 1. Remove the oil pan.
2. Remove the No. 1 and No. 2 solenoid valves.
- C** 1. Applying 490 kPa (5 kgf/cm², 71 psi) of compressed air, check that the solenoid valves do not leak air.
2. When battery positive voltage is supplied to the solenoid valves, check that the solenoid valves open.

OK

NG Replace solenoid valve.

2

Check harness and connector between ECM and solenoid (See page IN-30).

OK

NG Repair or replace harness or connector.

Proceed to next circuit inspection shown on matrix chart (See page AT1-58). However, when diagnostic trouble code 62 or 63 is displayed, check and replace ECM.

DTC 64 Lock-up Solenoid valve Circuit

CIRCUIT DESCRIPTION

The SL solenoid valve is turned ON and OFF by signals from the ECM to control the hydraulic pressure acting on the lock-up relay valve, which then controls operation of the lock-up clutch.

If a malfunction occurs in this circuit and diagnostic trouble code 64 is stored in memory, the O/D OFF indicator light does not blink.

Fail Safe Function

If the ECM detects a malfunction, it turns the lock-up solenoid valve OFF.

DTC No.	Diagnostic Trouble Code Detection Condition	Trouble Area
64	<p>(a) Solenoid resistance is $8\ \Omega$ or lower (short circuit) when solenoid energized.</p> <p>(b) Solenoid resistance is $100\ \text{k}\Omega$ or higher (open circuit) when solenoid is not energized.</p> <p>ECM memorizes diag. trouble code 64 if about (a) or (b) condition is detected once or more, but ECM does not start O/D OFF indicator light blinking.</p>	<ul style="list-style-type: none"> · Lock-up solenoid valve · Harness or connector between lock-up solenoid valve and ECM · ECM

WIRING DIAGRAM

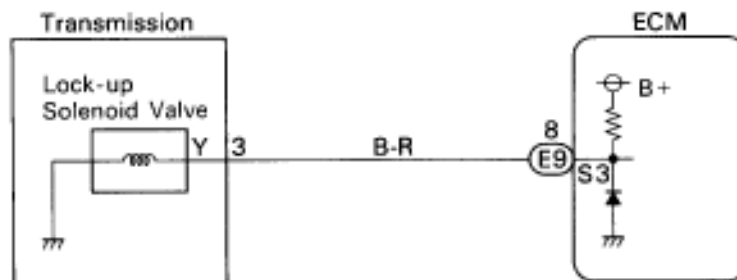

Q04350

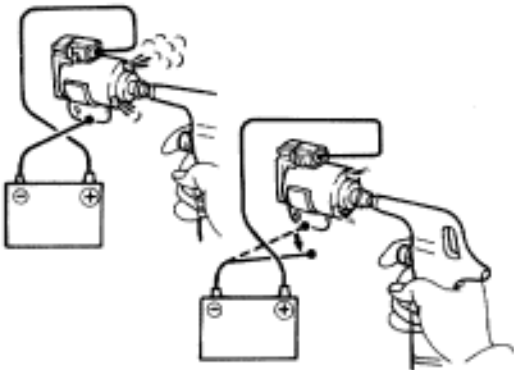
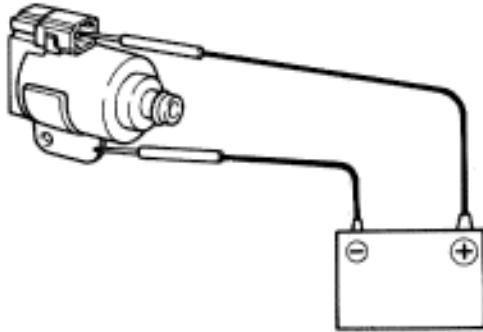
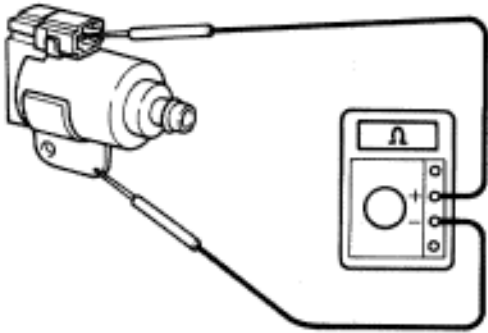
1**Check lock-up solenoid valve.**

Q04439
Q04440
Q04441

Electrical Check

- P** 1. Jack up the vehicle.
2. Remove the oil pan.
3. Disconnect the lock-up solenoid valve connector.

C Measure resistance between lock-up solenoid connector and solenoid body.

OK Resistance: 10 – 16 Ω

C Connect lock-up solenoid valve operation noise when battery positive voltage is applied to the solenoid connector terminal and solenoid body.

OK The lock-up solenoid valve makes operation noise.

Mechanical Check

P Remove lock-up solenoid valve from valve body.

- C** 1. Applying 490 kPa (5 kgf/cm², 71 psi) of compressed air, check that the solenoid valve does not leak air.
2. When battery positive voltage is supplied to the solenoid valve, check that the solenoid valve opens.

OK**NG**

Replace lock-up solenoid valve.

2**Check harness and connector between lock-up solenoid valve and ECM**
(See page [IN-30](#)).**OK****NG**

Repair or replace harness or connector.

Proceed to next circuit inspection shown on matrix chart (See page [AT1-58](#)). However, when diagnostic trouble code 64 is displayed, check and replace ECM.

Throttle Position Sensor Circuit

CIRCUIT DESCRIPTION

The throttle position sensor detects the throttle valve opening angle and sends signals to ECM.

WIRING DIAGRAM

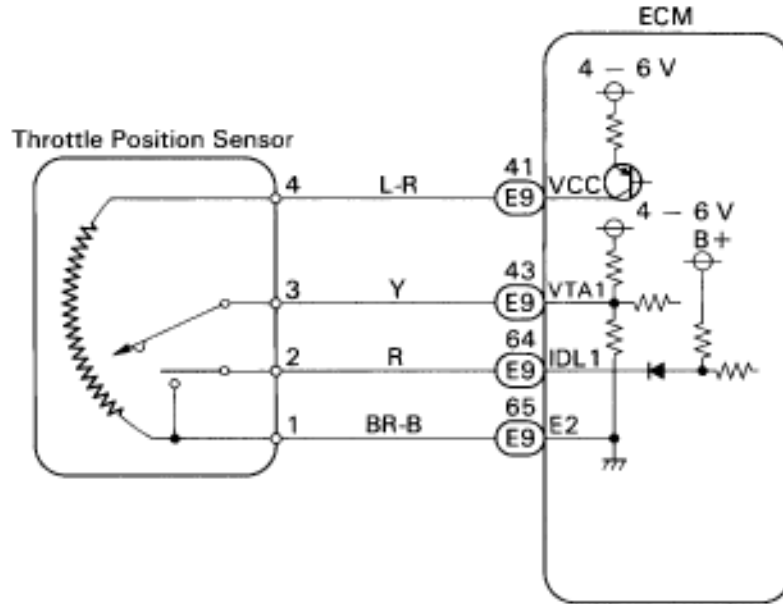

Q04351

INSPECTION PROCEDURE

1 Check throttle position signal.

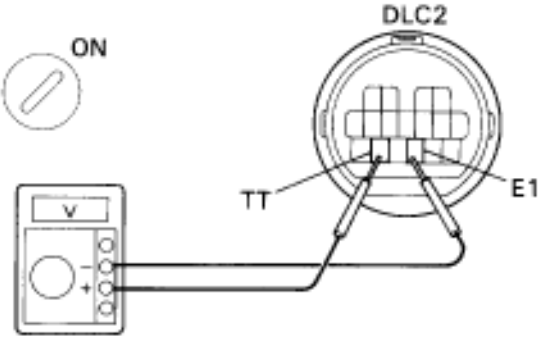

AB0119
AT5630

P Turn ignition switch ON.

C Check voltage at the terminal TT of the DLC2 while gradually depressing the accelerator pedal from the fully closed position to the fully opened position.

OK Voltage changes from 0 V to 8 V by stages.

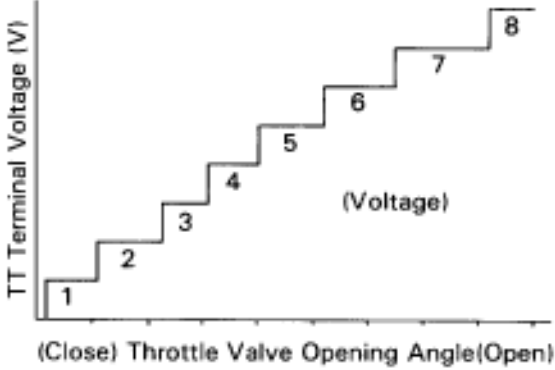

Hint Do not depress the brake pedal during this test. The voltage will stay at 0 V if depressed.

NG

OK Proceed to next circuit inspection shown on matrix chart (See page [AT1-58](#)).

2 Check throttle position sensor (See page [EG-219](#)).

OK

NG Replace throttle position sensor.

3 Check harness and connector between ECM and throttle position sensor (See page [IN-30](#)).

OK

NG Repair or replace harness or connector.

Check and replace ECM.

Kick-down Switch Circuit

CIRCUIT DESCRIPTION

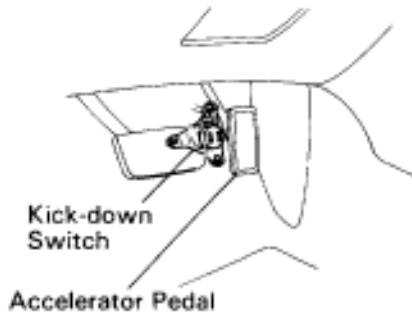

Q04246

The kick-down switch is turned on when the accelerator pedal is depressed beyond the full throttle opening and sends signals to ECM.

When the kick-down switch is turned on, the ECM controls gear shifting according to the programmed shift diagrams.

If a short circuit develops in the kick-down switch, the ECM disregards the kick-down signals and controls shifting at the normal shift points.

WIRING DIAGRAM

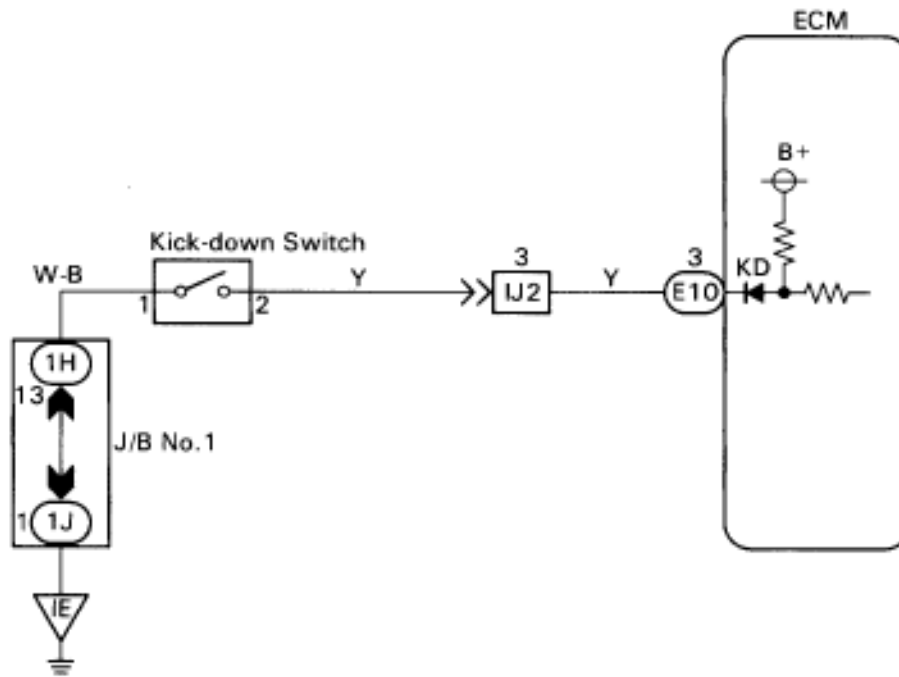

Q04321

INSPECTION PROCEDURE

1 Check voltage between terminal KD of ECM connector and body ground.

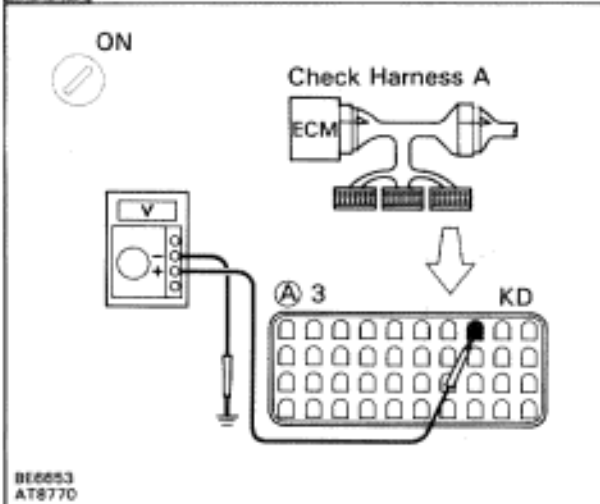

- P** 1. Connect the Check Harness A to the ECM (See page [EG-404](#)).
2. Turn ignition switch ON.
- C** Measure voltage between terminal KD of ECM connector and body ground when accel. pedal is fully depressed or not.

OK

Accel. pedal	Voltage
Fully depressed (Kick-down SW is ON)	Below 3 V
Released (Kick-down SW is OFF)	9 - 14 V

NG

OK

Proceed to next circuit inspection shown on matrix chart (See page [AT1-58](#)).

2 Check kick-down switch.

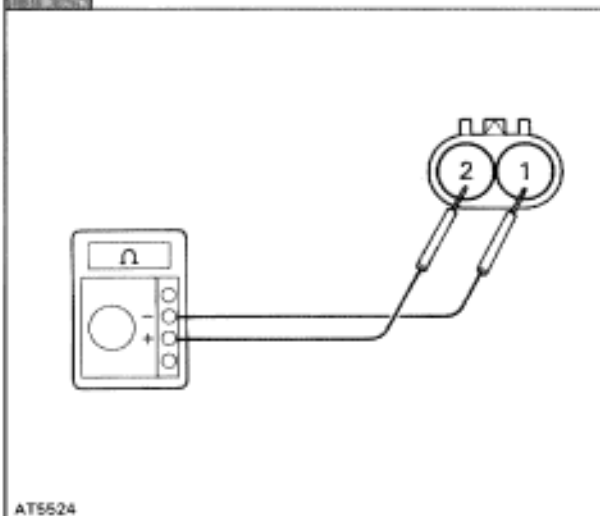

- C** 1. Disconnect kick-down switch connector (See page [AT1-15](#)).
2. Measure voltage between terminals 1 and 2 of kick-down switch connector when kick-down switch is on and off.

OK

Kick-down switch	Resistance
ON	C Ω (continuity)
OFF	$\infty \Omega$ (open)

OK

NG

Replace kick-down switch.

3 Check harness and connector between ECM and kick-down switch, kick-down switch and body ground (See page [IN-30](#)).

OK

NG

Repair or replace harness connector.

Check and replace ECM.

Park Neutral Position Switch Circuit

CIRCUIT DESCRIPTION

The park/neutral position switch detects the shift lever position and sends signals to ECM.
 The ECM receives signals (NSW, 2 and L) from the park/neutral position switch. When the signal is not sent to the ECM from the park/neutral position switch, the ECM judges that the shift lever is in the D position.

WIRING DIAGRAM

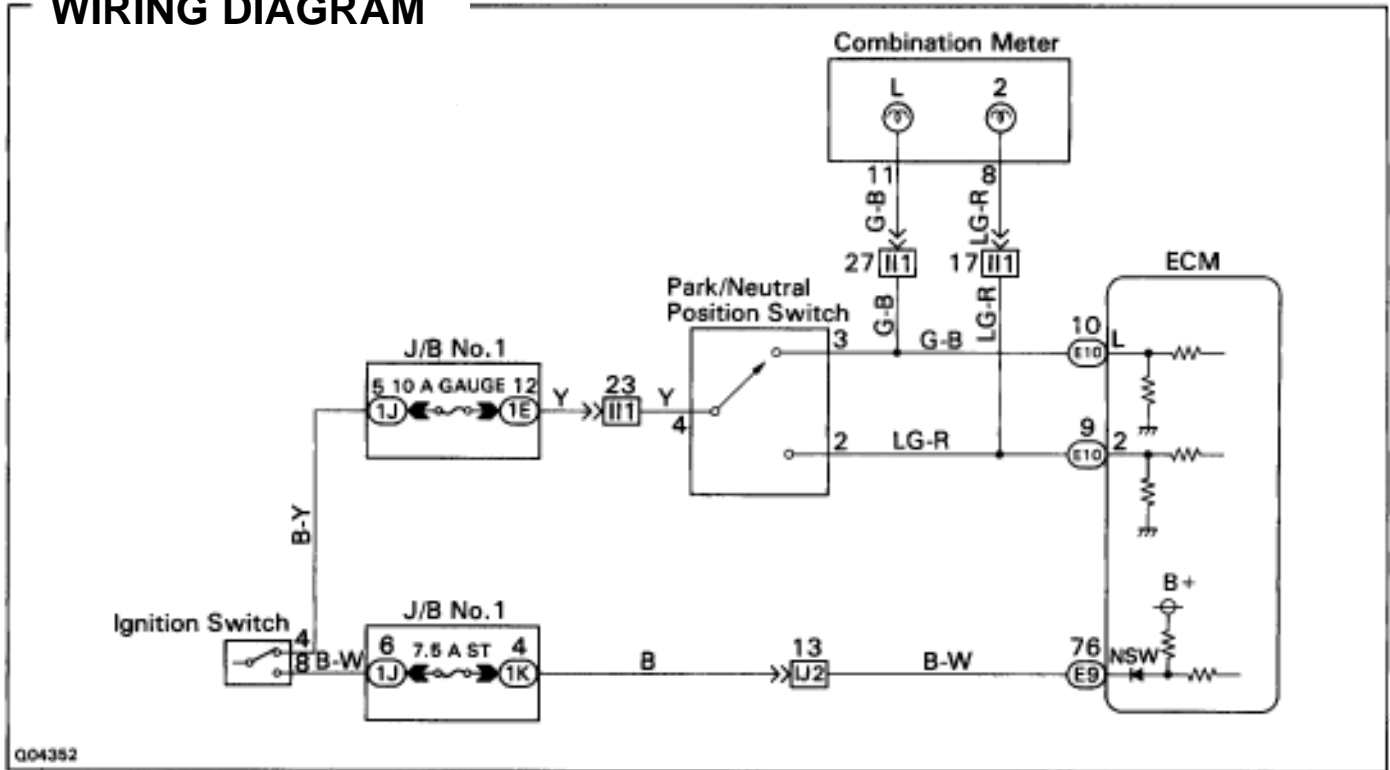

INSPECTION PROCEDURE

1 **Check voltage between terminals NSW, 2, L of ECM connector and body ground.**

8E6653
Q04365

P 1. Connect the Check Harness A to the ECM (See page [EG-404](#)).

2. Turn ignition switch ON.

C Measure voltage between terminals NSW, 2, L of ECM connector and body ground when the shift lever is positioned to the following positions.

OK

Position	NSW-body ground	2-body ground	L-body ground
P, N	3 V	Below 1.5 V	Below 1.5 V
R	9 – 14 V*	Below 1.5 V	Below 1.5 V
D	9 – 14 V	Below 1.5 V	Below 1.5 V
2	9 – 14 V	7.5 V – 14 V	Below 1.5 V
L	9 – 14 V	Below 1.5 V	7.5 V – 14 V

*: The voltage will drop slightly due to lighting up of the back up light.

NG

OK Proceed to next circuit inspection shown on matrix chart (See page [AT1-58](#)).

2 **Check park/neutral position switch.**

Q04369

P 1. Jack up the vehicle.

2. Remove park/neutral position switch (See page [AT1-15](#)).

C Check continuity between each terminal shown below when the shift lever is positioned to each position.

Shift Position \ Terminal	Terminal								
	6	5	4	7	8	10	9	2	3
P	○—○		○—○						
R			○—○		○—○				
N	○—○		○—○			○—○			
D			○—○				○—○		
2			○—○					○—○	
L			○—○						○—○

OK

NG Replace park/neutral position switch.

3 **Check harness and connector between battery and park/neutral position switch, park/neutral position switch and ECM (See page [IN-30](#)).**

OK

NG Repair or replace harness and connector.

Check and replace ECM.

Stop Light Switch Circuit

CIRCUIT DESCRIPTION

The purpose of this circuit is to prevent the engine from stalling, while driving in lock-up condition, when brakes are suddenly applied.

When the brake pedal is operated, this switch sends a signal to ECM. Then the ECM cancels operation of the lock-up clutch while braking is in progress.

WIRING DIAGRAM

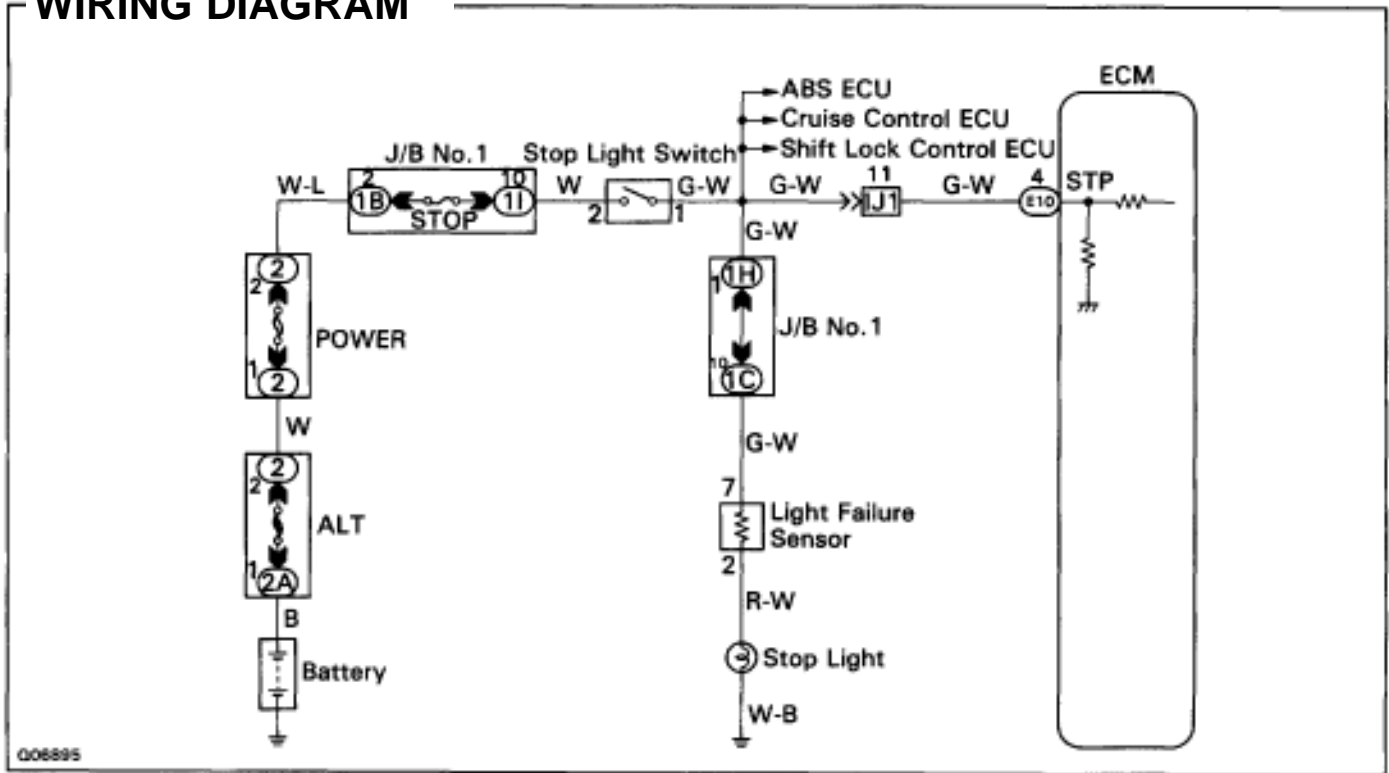

INSPECTION PROCEDURE

1	Check operation of stop light.
C	Check if the stop lights go on and off normally when the brake pedal is depressed and released.
<div style="border: 1px solid black; padding: 5px; display: inline-block; margin-bottom: 5px;">OK</div>	<div style="border: 1px solid black; padding: 5px; display: inline-block; margin-bottom: 5px;">NG</div>
<div style="border: 1px solid black; padding: 5px; display: inline-block;">Check and repair stop light circuit.</div>	
<div style="border: 1px solid black; padding: 5px; display: inline-block;">Go to 2 .</div>	

2 Check stop light signal.

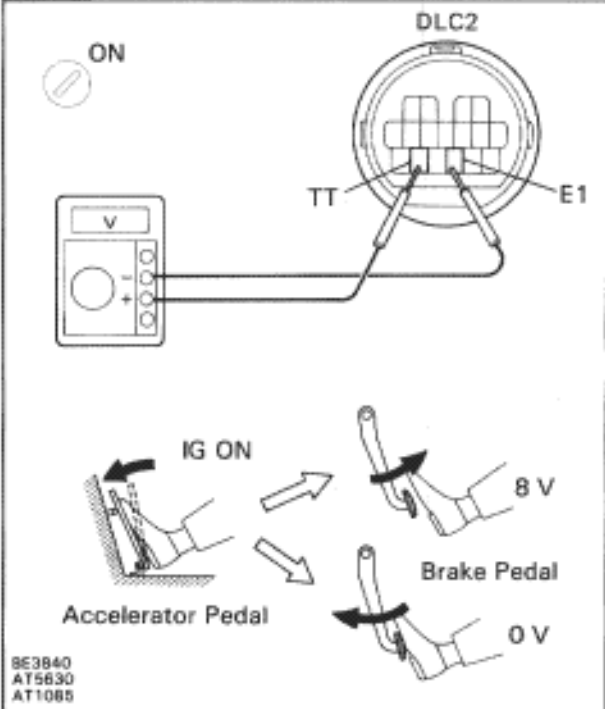

- C**
1. Connect a voltmeter to the terminals TT and E1 of the DLC2.
 2. Turn ignition switch ON (Do not start the engine).
 3. Fully depress the accelerator pedal until the voltmeter indicates 8 V and hold it.
 4. Depress and release the brake pedal and check the voltage.

OK

Brake pedal	Voltage
Depressed	0 V
Released	8 V

NG

OK Proceed to next circuit inspection shown on matrix chart (See page [AT1-58](#)).

3 Check harness and connector between ECM and stop light switch (See page [IN-30](#)).

OK

NG Repair or replace harness or connector

Check and replace ECM.

Pattern Select Switch Circuit

CIRCUIT DESCRIPTION

The ECM memory contains the shift programs for the NORMAL and MANUAL patterns, 2 position, and L position and the lock-up patterns. Following the programs corresponding to the signals from the pattern select switch, the park/neutral position switch and other various sensors the ECM switches the solenoid valves ON and OFF, thereby controlling the transmission gear change and the lock-up clutch operation.

WIRING DIAGRAM

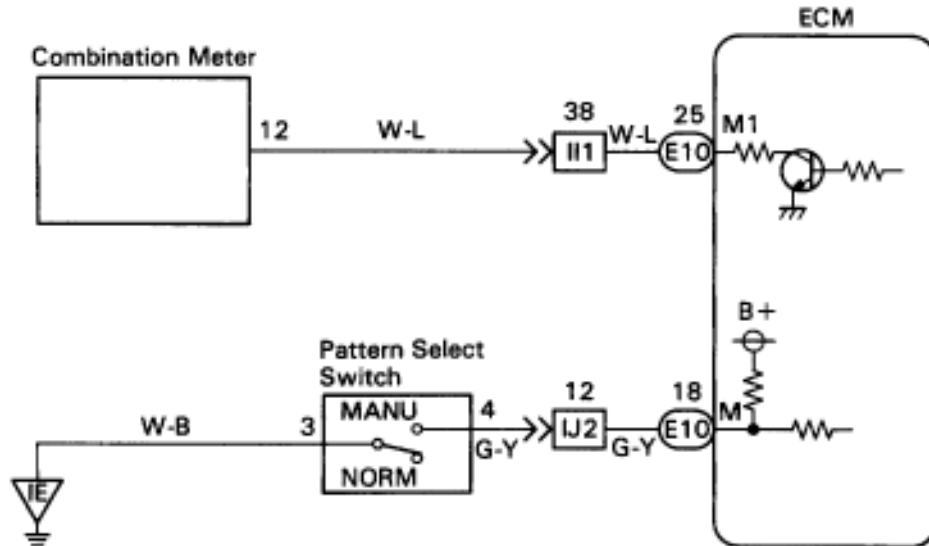

INSPECTION PROCEDURE

1

Check A/T fluid temp. sensor. (See page [AT1-64](#)).

OK
NG





Replace A/T fluid temp. sensor.

Go to **2** .

2

Check if A/T fluid is too hot.

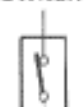

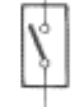
Pattern Select Switch	"MANU" Mode Indicator Light	Pattern Select Switch Point
		 ON
		 OFF

8E6653
Q04452

C 1. Turn ignition switch ON.
2. Check "MANU" mode indicator light when pattern select switch is pushed in to ON.

OK "MANU" mode indicator light comes on and stays on.

Hint If the A/T fluid temp. becomes too hot, the "MANU" mode indicator light flashes for several seconds and goes off. The driving mode then automatically changes from MANU mode to the NORM mode.

OK

NG Wait until the A/T fluid temp. is reduced.

3

Check voltage between terminal M of ECM connector and body ground.





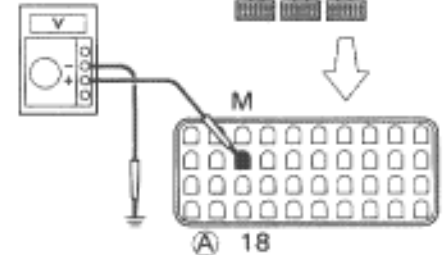

(A) 18

8E6653
AT8772

P 1. Connect the Check Harness A to the ECM (See page EG-404).
2. Turn ignition switch ON.

C Measure voltage between the terminal M of ECM connector and body ground when the pattern select switch is set to the MANU (MANUAL) position and NORM (NORMAL) position.

OK

Pattern select switch	Voltage
MANU	7.5 - 14 V
NORM	Below 1.5 V

Hint The ECM uses the Normal pattern signal if the Manual signal is not input.

NG

OK Proceed to next circuit inspection shown on matrix chart. (See page AT1-58)

Go to step 4.

4 Check pattern select switch.

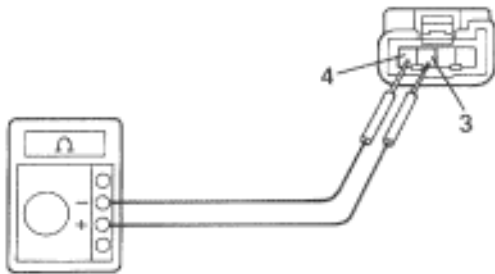

Q04367

P Disconnect the pattern select switch connector.

C Measure resistance between terminals 3 and 4 of the pattern select switch connector when the select switch is set to the MANU and NORM positions.

OK

Pattern	Resistance
MANU	0 Ω (continuity)
NORM	∞ Ω (open)

OK

NG

Replace pattern select switch.

5 Check harness and connector between battery and pattern select switch, pattern select switch and ECM (See page IN-30).

OK

NG

Repair or replace harness or connector.

Check and replace ECM.

O D Main Switch & O D OFF Indicator Light Circuit

CIRCUIT DESCRIPTION

The O/D main switch contacts go off when the switch is pushed in and come on when it is pushed out. In O/D main switch OFF position, the O/D OFF indicator light lights up, and the ECM prohibits shifting to overdrive. The ECM also causes the O/D OFF indicator light to blink when a malfunction is detected. In this case, connecting the terminals in the DLC2 or DLC1 can display the malfunction code.

WIRING DIAGRAM

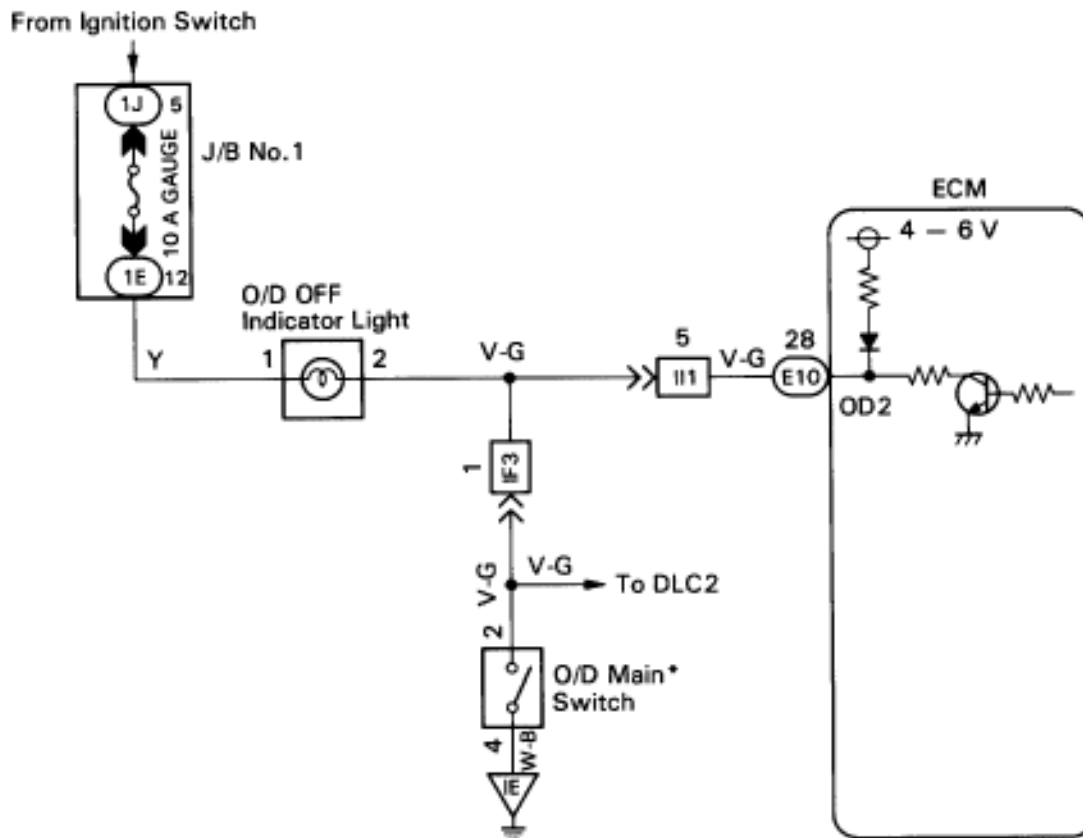

(*) O/D Main Switch
 Contacts go off with button pushed in.
 Contacts go on with button pushed out.

INSPECTION PROCEDURE

O/D OFF indicator light does not light up.

1 Check operation of O/D main switch.

C 1. Turn ignition switch ON.
2. Check "O/D OFF" indicator light when O/D main switch is pushed in to ON.

OK "O/D OFF" indicator light goes off.

C 3. Check "O/D OFF" indicator light when O/D main switch is pushed again, to OFF.

OK "O/D OFF" indicator light lights up.

Hint If the "O/D OFF" indicator light blinks when the O/D main switch is pushed in to ON, a malfunction is occurring in the system. Check the diagnostic trouble code.

OK

NG Go to step **4**.

2 Check voltage between terminal OD2 of ECM connector and body ground.

P 1. Connect the Check Harness A to the ECM (See page EG-404).
2. Turn ignition switch ON.

C Check voltage between terminal OD2 of the ECM and body ground.

OK

O/D Main Switch	Voltage
OFF	Below 3 V
ON	9 - 14 V

NG

OK Proceed to next circuit inspection shown on matrix chart (See page AT1-58).

3 Check harness and connector between O/D off indicator light and ECM (See page IN-30).

OK

NG Repair or replace harness or connector.

Check and replace ECM.

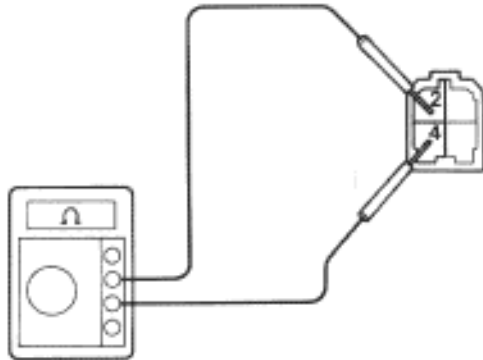
4**Check O/D main switch.**

AT5529

OK**C**

1. Disconnect the O/D main switch connector.
2. Measure resistance between terminals 2 and 4 of O/D main switch connector.

OK

O/D Main Switch	Resistance
ON	$\infty \Omega$ (open)
OFF	0 Ω (continuity)

NG

Replace O/D main switch.

Check and replace combination meter.
(See combination meter troubleshooting section on page [BE-41](#)).

O/D OFF indicator light remains ON

1**Check O/D main switch.****OK****NG**

Replace O/D main switch.

2**Check harness and connector between O/D off indicator light and ECM
(See page [IN-30](#)).****OK****NG**

Repair or replace harness or connector.

Check and replace ECM.

O/D OFF indicator light blinks

Do diagnostic trouble code check (See page [AT1-52](#)).

O D Cancel Signal Circuit

CIRCUIT DESCRIPTION

While driving with cruise control activated, in order to minimize gear shifting and provide smooth uphill cruising, overdrive may be prohibited temporarily in some conditions.

The Cruise Control ECU sends O/D cut signals to the ECM as necessary and the ECM cancels overdrive shifting until these signals are discontinued.

(For details, see the cruise control section, page [BE-162](#))

WIRING DIAGRAM

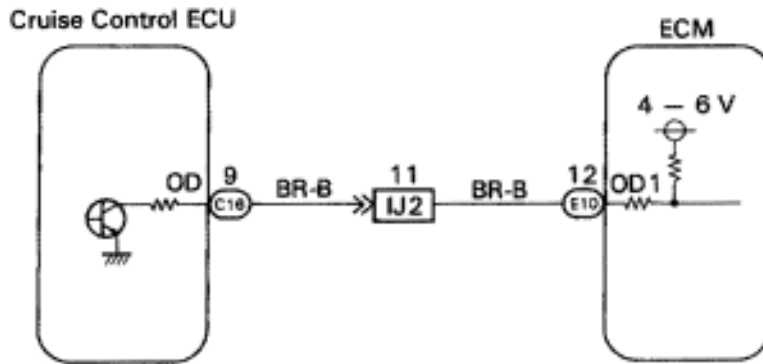

INSPECTION PROCEDURE

1	Check voltage between terminal OD1 of ECM connector and body ground.
<p>ON Check and replace ECM.</p> <p>Check Harness A</p> <p>12 OD1</p> <p>BE6653 AT8774</p>	<p>P 1. Connect the Check Harness A to the ECM (See page EG-404).</p> <p>2. Turn ignition switch ON.</p> <p>C Measure voltage between terminal OD1 of ECM connector and body ground.</p> <p>OK Voltage: 4 – 6 V</p>
NG	OK Proceed to next circuit inspection shown on matrix chart (See page AT1-58).

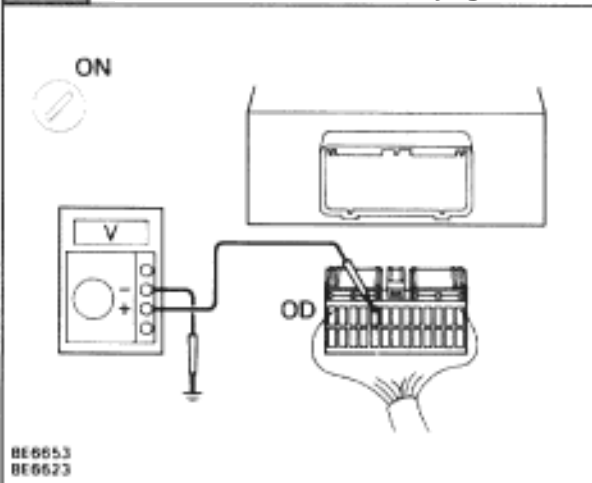
2**Check voltage between terminal OD of Cruise Control ECU harness side connector and body ground.****P**

1. Disconnect Cruise Control ECU connector.
2. Turn ignition switch ON.

C

Measure voltage between terminal OD of Cruise Control ECU harness side connector and body ground.

OK

Voltage 4 – 6 V

NG**OK**

Check and replace Cruise Control ECU.

3**Check harness and connector between Cruise Control ECU and ECM (See page IN-30).****OK****NG**

Repair or replace harness or connector.

Check and replace ECM.

TE1 Terminal Circuit

CIRCUIT DESCRIPTION

ECM displays diagnostic trouble codes using the O/D OFF indicator light when terminals TE1 and E1 of the DLC2 or DLC1 are connected.

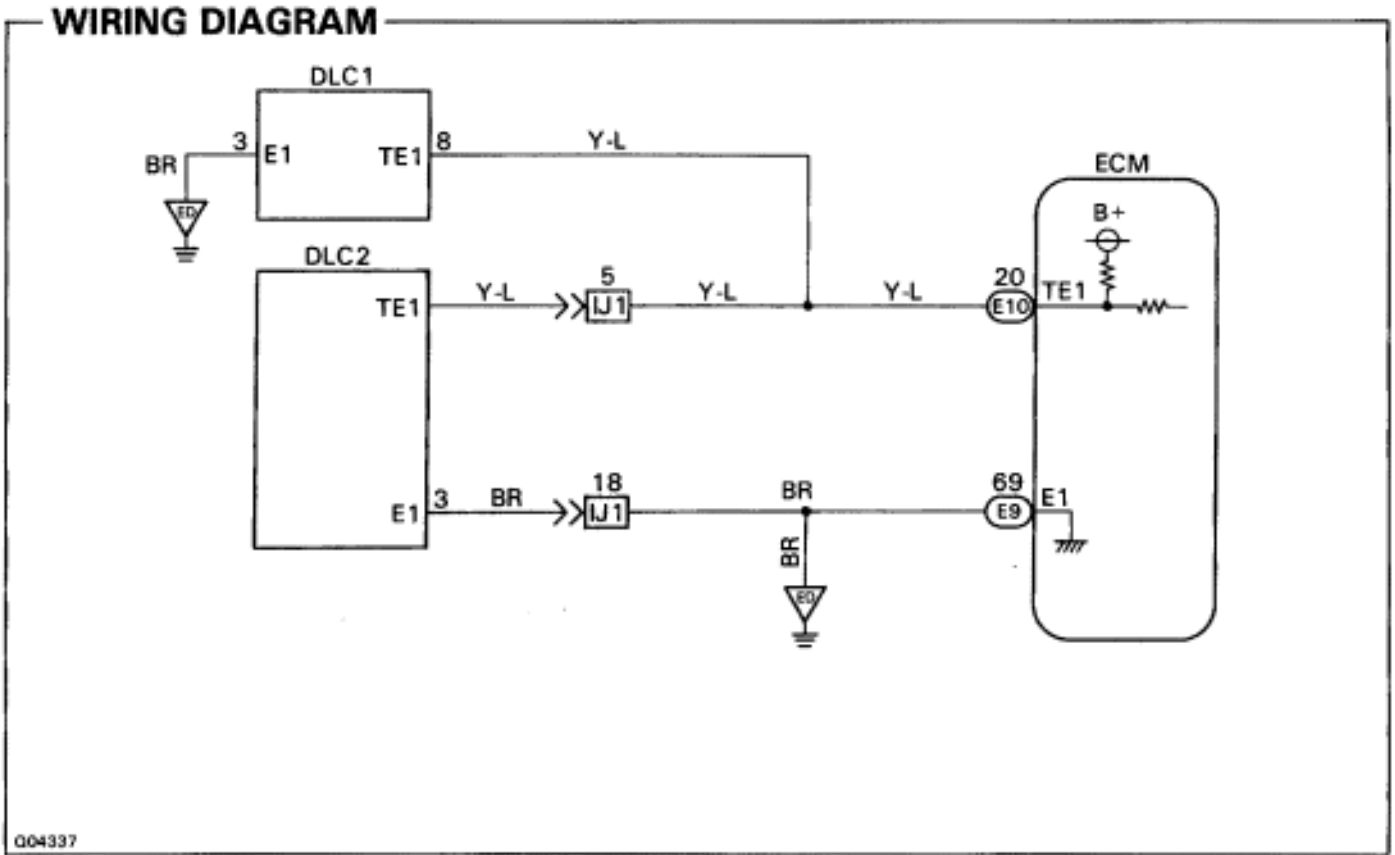

INSPECTION PROCEDURE

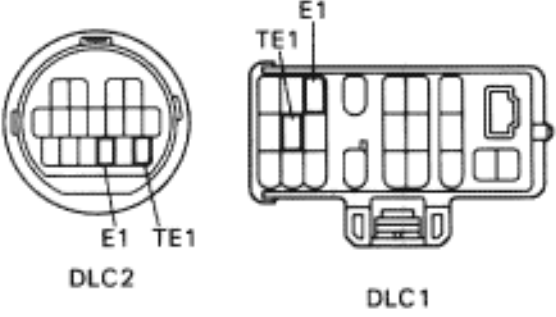
1	Check voltage between terminal TE1 and E1 of DLC2 or DLC1.
 <p>S-17-1 In-23-1-A</p>	<p>C Measure voltage between terminals TE1 and E1 of DLC2 or DLC1.</p> <p>OK Voltage 4 – 6 V</p>
NG	OK Proceed to next circuit inspection shown on matrix chart (See page AT1-58).

2	Check harness and connector between ECM and DLC2, DLC1 and body ground (See page IN-30).
OK	NG Repair or replace harness or connector.

Check and replace ECM.

TT Terminal Circuit

CIRCUIT DESCRIPTION

Checks of ECM input and output signals related to the throttle position sensor, brakes, shift position and other circuits can be performed by measuring the voltages at terminal TT of the DLC2

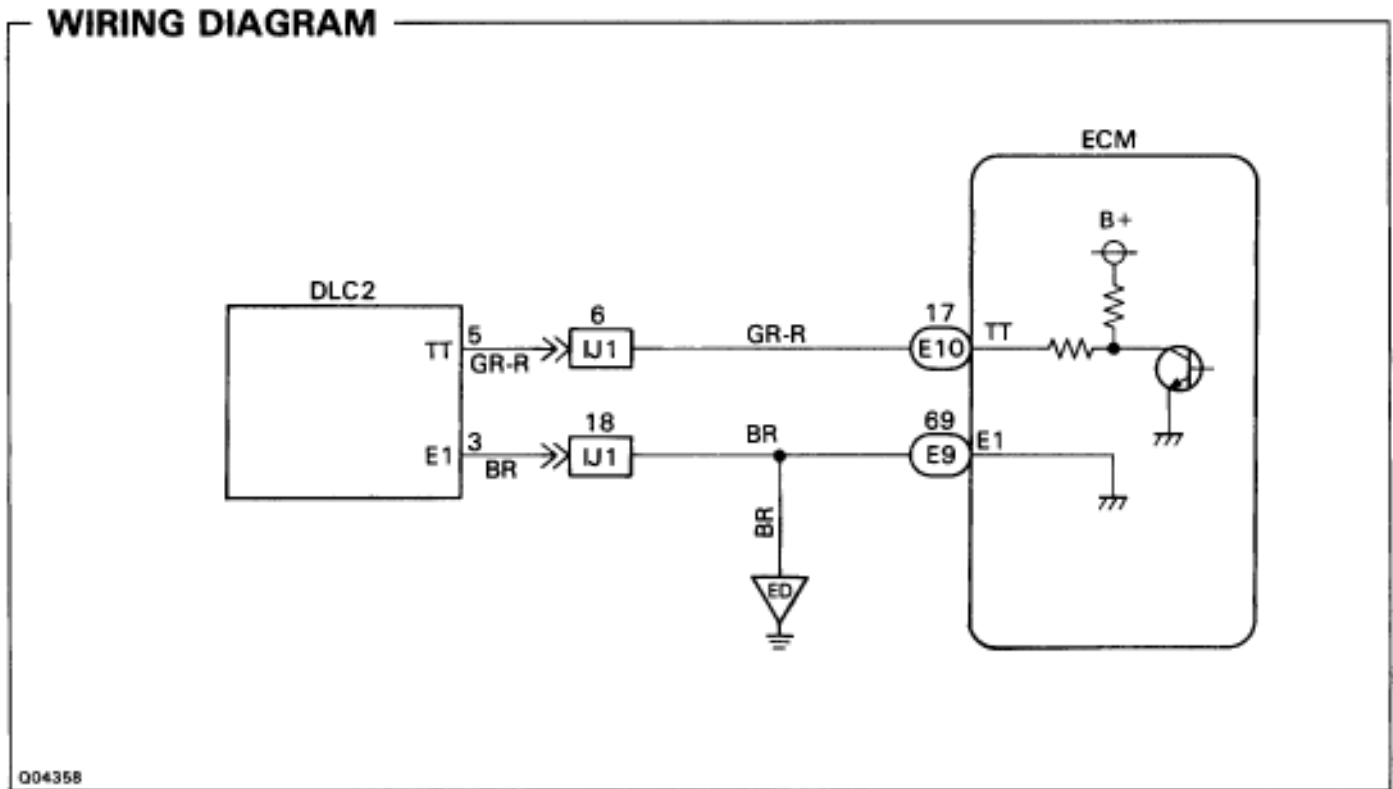

INSPECTION PROCEDURE

1

Check harness and connector between ECM and DLC2 and body ground
(See page [IN-30](#)).

OK

NG

Repair or replace harness or connector.

Check and replace ECM.

SERVICE SPECIFICATIONS

SERVICE DATA

Line pressure (wheel locked)	Engine idling			
	D position	363–422 kPa	3.7–4.3 kgf/cm ²	53–61 psi
	R position	500–598 kPa	5.1–6.1 kgf/cm ²	73–88 psi
	AT stall (Throttle valve fully opened)			
	D position	902–1,147 kPa	9.2–11.7 kgf/cm ²	131–166 psi
	R position	1,236–1,589 kPa	12.6–16.2 kgf/cm ²	179–230 psi
Engine stall revolution (D and R position)		2,200±150 rpm		
Time lag	N → D position	Less than 1.2 seconds		
	N → R position	Less than 1.5 seconds		
Engine idle speed (In N position and air conditioner OFF)		700±50 rpm		
Throttle cable adjustment (Throttle valve fully closed)		Between boot and face and inner cable stopper		
		0–1 mm	0–0.04 in.	
Drive plate runout	Max	0.20 mm	0.0079 in.	
Torque converter clutch runout	Max	0.30 mm	0.0118 in.	

SHIFT POINT

NORM Mode

Shift Position	Shifting Point		Vehicle speed km/h (mph)
D	Throttle valve fully opened	1→2	53–62 (33–39)
		2→3	104–112 (65–70)
		3→O/D	163–175 (101–109)
		O/D→3	157–169 (98–105)
	Throttle valve fully closed	3→2	98–105 (61–65)
		2→1	42–48 (26–30)
		3→O/D	34–39 (21–24)
		O/D→3	20–25 (12–16)
2	Throttle valve fully opened	1→2	53–62 (33–39)
		* 3→2	121–132 (75–82)
		2→1	42–48 (26–330)
L	Throttle valve fully opened	* 2→1	48–53 (30–33)

MANU Mode

Shift Position	Shifting Point		Vehicle speed km/h (mph)
D	Throttle valve fully opened	2→3	104–112 (65–70)
		3→O/D	163–175 (101–109)
		O/D→3	157–169 (98–109)
	Throttle valve fully closed	3→2	98–105 (61–65)
		3→O/D	163–175 (101–109)
		O/D→3	20–25 (12–16)
2	Throttle valve fully opened	* 3→2	121–132 (75–82)
L	Throttle valve fully opened	* 2→1	48–53 (30–33)

LOCK-UP POINT**NORM Mode**

D position Throttle valve opening 5%	km/h (mph)	Lock-up ON	Lock-up OFF
3rd Gear (O/D switch OFF)		56-62 (35-39)	53-59 (35-39)
O/D Gear		56-62 (35-39)	53-59 (35-39)

MANU Mode

D position Throttle valve opening 5%	km/h (mph)	Lock-up ON	Lock-up OFF
3rd Gear (O/D switch OFF)		98-105 (61-65)	92-99 (57-62)
O/D Gear		163-175 (101-109)	56-62 (35-39)

HINT:

- (1) There is no lock-up in the 2 and L positions.
- (2) In the following cases, the lock-up will be released regardless of the lock-up pattern.
 - When the throttle valve is completely closed.
 - When the brake light switch is ON.
- (3) Shift up to 3rd will not occur when the engine coolant temp. is below 35°C (95°F) and the vehicle speed is below 40 km/h (25 mph).
- (4) Shift-up to O/D will not occur when the engine coolant temp. is below 60°C (140°F) and the vehicle speed is below 63 km/h (39 mph)
- (5) When the vehicle speed drops to 10 km/h (6 mph) or more below the cruise control set vehicle speed, shift down from O/D to 3rd occurs.

TORQUE SPECIFICATIONS

Part tightened		N·m	kgf·cm	ft·lbf
Engine block X Transmission	14 mm	37	380	27
	17 mm	72	730	53
Rear mounting X Body		25	260	19
Extension housing X Transmission case		36	370	27
Valve body X Transmission case		10	100	7
Oil strainer		10	100	7
Oil pan		7.4	75	65 in·lbf
No.1 vehicle speed sensor		16	160	12
No.2 vehicle speed sensor		5.4	55	48 in·lbf
Solenoid wiring stopper plate		5.4	55	48 in·lbf
Rear center floor crossmember brace X Body		13	130	9
Propeller shaft X Differential		79	805	58
Manual shift linkage X Control shaft lever		13	130	9
Center support bearing X Body		49	500	36
Throttle cable X Transmission case		5.4	55	48 in·lbf
Cooler pipe union nut		34	350	25
Drive plate X Crankshaft		74	750	54
Torque converter clutch X Drive plate		33	340	25
Control shaft lever X Park/Neutral position switch		16	160	12
A/T fluid temp. sensor		15	150	11
Drain plug		20	205	15
Solenoid valve X Valve body		10	100	7
Parking lock pawl bracket		7.4	75	65 in·lbf
Transmission mounting bracket X Extension housing		25	250	18
Heat insulator X Body		5.4	55	48 in·lbf
Starter		37	380	27