

# 200SX/S14 Silvia

## Workshop manuals



A special thanks to all the people who made this manual possible (including Mr nissan!)

# Index

General info .....	PDF page 10
Maintenance .....	PDF page N/A
Engine Mechanical .....	PDF page 40
Engine Lub & cooling .....	PDF page 119
Engine Control (ECU) .....	PDF page 139
Accelerator, Fuel & Exhaust .....	PDF page 349
Clutch .....	PDF page 357
Manual Gbox.....	PDF page 370
Auto Gbox .....	PDF page N/A
Tailshaft & diff .....	PDF page 399
Front axle & suspension .....	PDF page 436
Rear axle & suspension .....	PDF page 451
Brakes (tip: get better pads!) .....	PDF page 475
Steering .....	PDF page 542
Restraints .....	PDF page 557
Body & trims .....	PDF page 572
Heater & Aircon .....	PDF page 597
Electrical .....	PDF page 672
Alphabetical printed index .....	PDF page 811
*ECU design chart .....	PDF page 816

## QUICK REFERENCE INDEX

GENERAL INFORMATION \_\_\_\_\_ GI

MAINTENANCE \_\_\_\_\_ MA

ENGINE MECHANICAL \_\_\_\_\_ EM

ENGINE LUBRICATION & \_\_\_\_\_  
COOLING SYSTEMS LC

ENGINE CONTROL SYSTEM \_\_\_\_\_ EC

ACCELERATOR CONTROL, FUEL & \_\_\_\_\_  
EXHAUST SYSTEMS FE

CLUTCH \_\_\_\_\_ CL

MANUAL TRANSMISSION \_\_\_\_\_ MT

AUTOMATIC TRANSMISSION \_\_\_\_\_ AT

PROPELLER SHAFT & \_\_\_\_\_  
DIFFERENTIAL CARRIER PD

FRONT AXLE & FRONT SUSPENSION \_\_\_\_\_ FA

REAR AXLE & REAR SUSPENSION \_\_\_\_\_ RA

BRAKE SYSTEM \_\_\_\_\_ BR

STEERING SYSTEM \_\_\_\_\_ ST

RESTRAINT SYSTEM \_\_\_\_\_ RS

BODY & TRIM \_\_\_\_\_ BT

# NISSAN

MODEL S14 SERIES

## PRECAUTIONS

Observe the following precautions to ensure safe and proper servicing.

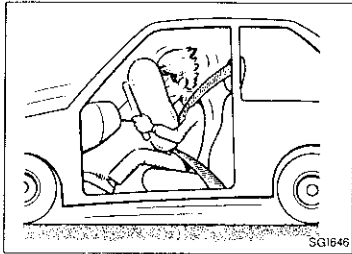

### Precautions for Supplemental Restraint System "AIR BAG" and "SEAT BELT PRE-TENSIONER"

The Supplemental Restraint System "Air Bag" and "Seat belt pre-tensioner", used along with a seat belt, help to reduce the risk or severity of injury to the driver and front passenger in a frontal collision. The Supplemental Restraint System consists of air bag modules (located in the center of the steering wheel and on the instrument panel on the passenger side), a seat belt pre-tensioner, a diagnosis sensor unit, warning lamp, wiring harness and spiral cable. Information necessary to service the system safely is included in the RS section of this Service Manual.

#### WARNING:

- To avoid rendering the SRS inoperative, which could increase the risk of personal injury or death in the event of a collision which would result in air bag inflation, all maintenance must be performed by an authorized NISSAN dealer.
- Improper maintenance, including incorrect removal and installation of the SRS, can lead to personal injury caused by unintentional activation of the system.
- All SRS electrical wiring harnesses and connectors are covered with yellow outer insulation. Do not use electrical test equipment on any circuit related to the SRS.

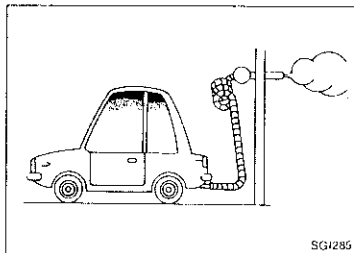

### General Precautions

- Do not operate the engine for an extended period of time without proper exhaust ventilation. Keep the work area well ventilated and free of any flammable materials. Special care should be taken when handling any flammable or poisonous materials, such as gasoline, refrigerant gas, etc. When working in a pit or other enclosed area, be sure to properly ventilate the area before working with hazardous materials. Do not smoke while working on the vehicle.

## PRECAUTIONS

### General Precautions (Cont'd)

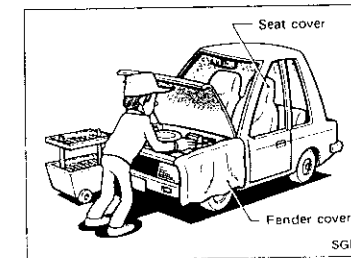
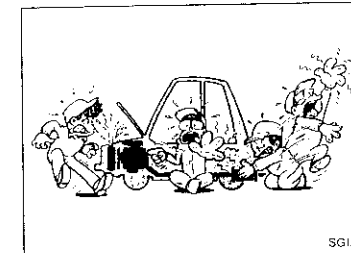
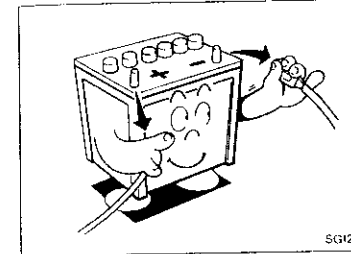
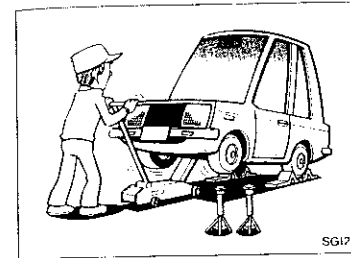

- Before jacking up the vehicle, apply wheel chocks or other tire blocks to the wheels to prevent the vehicle from moving. After jacking up the vehicle, support the vehicle weight with safety stands at the points designated for proper lifting before working on the vehicle. These operations should be done on a level surface.
- When removing a heavy component such as the engine or transaxle/transmission, be careful not to lose your balance and drop them. Also, do not allow them to strike adjacent parts, especially the brake tubes and master cylinder.

- Before starting repairs which do not require battery power, always turn off the ignition switch, then disconnect the ground cable from the battery to prevent accidental short circuit.

- To prevent serious burns, avoid contact with hot metal parts such as the radiator, exhaust manifold, tail pipe and muffler. Do not remove the radiator cap when the engine is hot.

- Before servicing the vehicle, protect fenders, upholstery and carpeting with appropriate covers. Take caution that keys, buckles or buttons on your person do not scratch the paint.

- Clean all disassembled parts in the designated liquid or solvent prior to inspection or assembly.
- Replace oil seals, gaskets, packings, O-rings, locking washers, cotter pins, self-locking nuts, etc. with new ones.
- Replace inner and outer races of tapered roller bearings and needle bearings as a set.
- Arrange the disassembled parts in accordance with their assembled locations and sequence.
- Do not touch the terminals of electrical components which use microcomputers (such as ECMs). Static electricity may damage internal electronic components.

## PRECAUTIONS

### General Precautions (Cont'd)

- After disconnecting vacuum or air hoses, attach a tag to indicate the proper connection.
- Use only the fluids and the lubricants specified in MA section and HA section or their equivalents.
- Use approved bonding agent, sealants or their equivalents when required.
- Use tools and recommended special tools where specified for safe and efficient service repairs.
- When repairing the fuel, oil, water, vacuum or exhaust systems, check all affected lines for leaks.
- Dispose of drained oil or the solvent used for cleaning parts in an appropriate manner.

### Precautions for Multiport Fuel Injection System or ECCS Engine

- Before connecting or disconnecting multiport fuel injection system or ECM (ECCS control module) harness connector, be sure to turn the ignition switch to the "OFF" position and disconnect the negative battery terminal. Otherwise, there may be damage to ECM.
- Before disconnecting pressurized fuel line from fuel pump to injectors, be sure to release fuel pressure to eliminate danger.
- Be careful not to jar components such as ECM and mass air flow sensor.

### Precautions for Three Way Catalyst

If a large amount of unburned fuel flows into the converter, the converter temperature will be excessively high. To prevent this, follow the procedure below:

1. Use unleaded gasoline only. Leaded gasoline will seriously damage the three way catalyst.
2. When checking for ignition spark or measuring engine compression, make tests quickly and only when necessary.
3. Do not run engine when the fuel tank level is low, otherwise the engine may misfire causing damage to the converter.

Do not place the vehicle on flammable material. Keep flammable material off the exhaust pipe and the three way catalyst.

### Precautions for Turbocharger

The turbocharger turbine revolves at extremely high speeds and becomes very hot. Therefore, it is essential to maintain a clean supply of oil flowing through the turbocharger and to follow all required maintenance instructions and operating procedures.

For proper operation of the system, follow the procedure below.

1. Always use the recommended oil. Follow the instructions for proper time to change the oil and proper oil level.
2. Avoid accelerating engine to a high rpm immediately after starting.
3. If engine had been operating at high rpm for an extended period of time, let it idle for a few minutes prior to shutting it off.

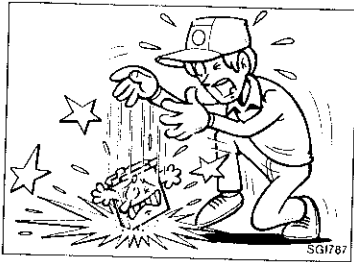

## PRECAUTIONS

### Engine Oils

Prolonged and repeated contact with used engine oil may cause skin cancer. Try to avoid direct skin contact with used oil. If skin contact is made, wash thoroughly with soap or hand cleaner as soon as possible.

### HEALTH PROTECTION PRECAUTIONS

- Avoid prolonged and repeated contact with oils, particularly used engine oils.
- Wear protective clothing, including impervious gloves where practicable.
- Do not put oily rags in pockets.
- Avoid contaminating clothes, particularly underpants, with oil.
- Heavily soiled clothing and oil-impregnated footwear should not be worn. Overalls must be cleaned regularly.
- First Aid treatment should be obtained immediately for open cuts and wounds.
- Use barrier creams, applying them before each work period, to help the removal of oil from the skin.
- Wash with soap and water to ensure all oil is removed (skin cleansers and nail brushes will help). Preparations containing lanolin replace the natural skin oils which have been removed.
- Do not use gasoline, kerosene, diesel fuel, gas oil, thinners or solvents for cleaning skin.
- If skin disorders develop, obtain medical advice without delay.
- Where practicable, degrease components prior to handling.
- Where there is a risk of eye contact, eye protection should be worn, for example, chemical goggles or face shields; in addition an eye wash facility should be provided.

### ENVIRONMENTAL PROTECTION PRECAUTIONS

Burning used engine oil in small space heaters or boilers can be recommended only for units of approved design. The heating system must meet the requirements of HM Inspectorate of Pollution for small burners of less than 0.4 MW. If in doubt check with the appropriate local authority and/or manufacturer of the approved appliance.

Dispose of used oil and used oil filters through authorized waste disposal contractors to licensed waste disposal sites, or to the waste oil reclamation trade. If in doubt, contact the local authority for advice on disposal facilities.

It is illegal to pour used oil on to the ground, down sewers or drains, or into water courses.

**The regulations concerning the pollution of the environment will vary from country to country.**

GI

WA

RM

LC

EG

FE

OL

MT

ST

FD

FA

RA

RA

ST

PS

BT

RA

EL

ED

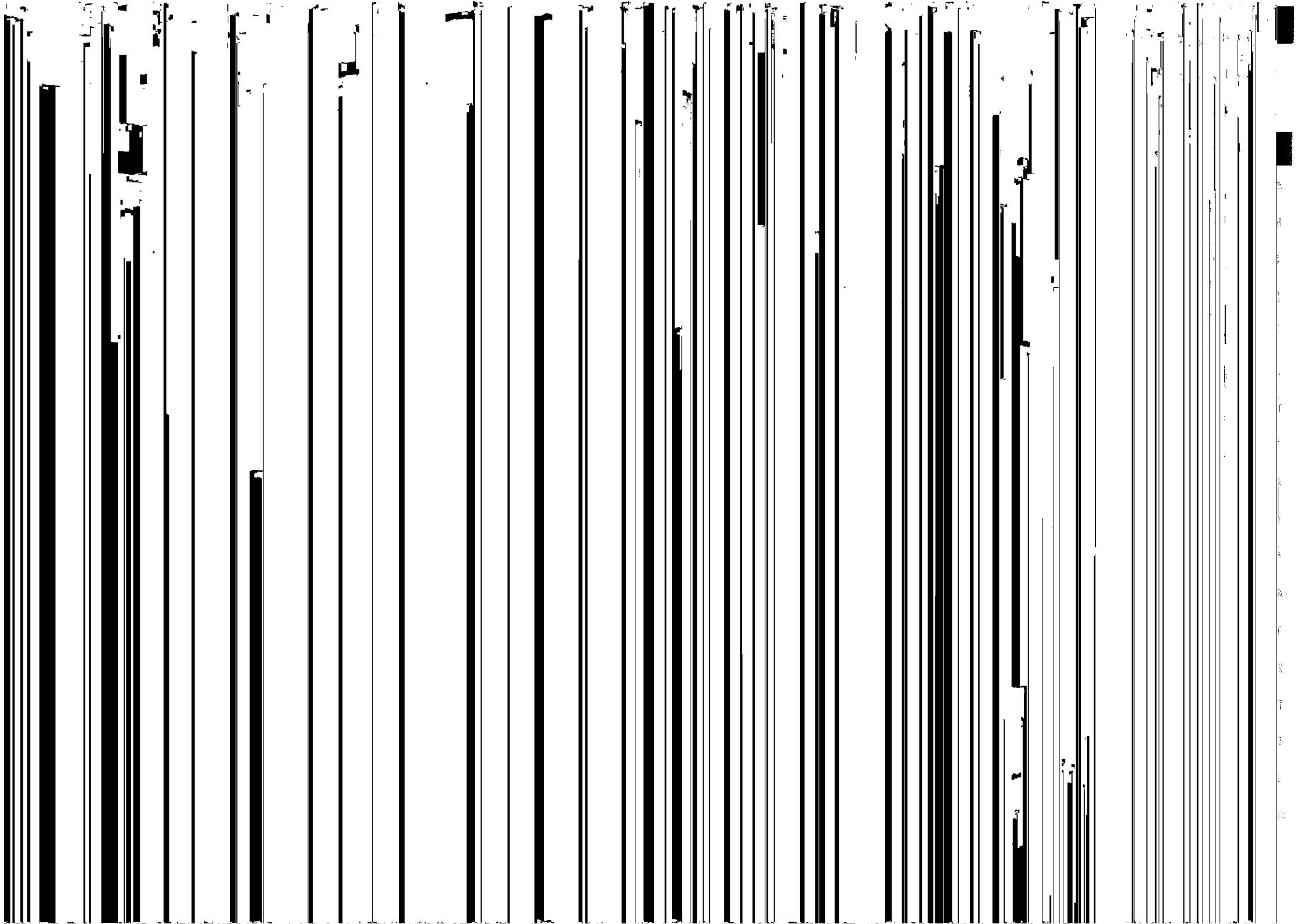

## HOW TO READ WIRING DIAGRAMS

### Sample/Wiring Diagram — EXAMPL — (Cont'd)

#### OPTIONAL SPLICE

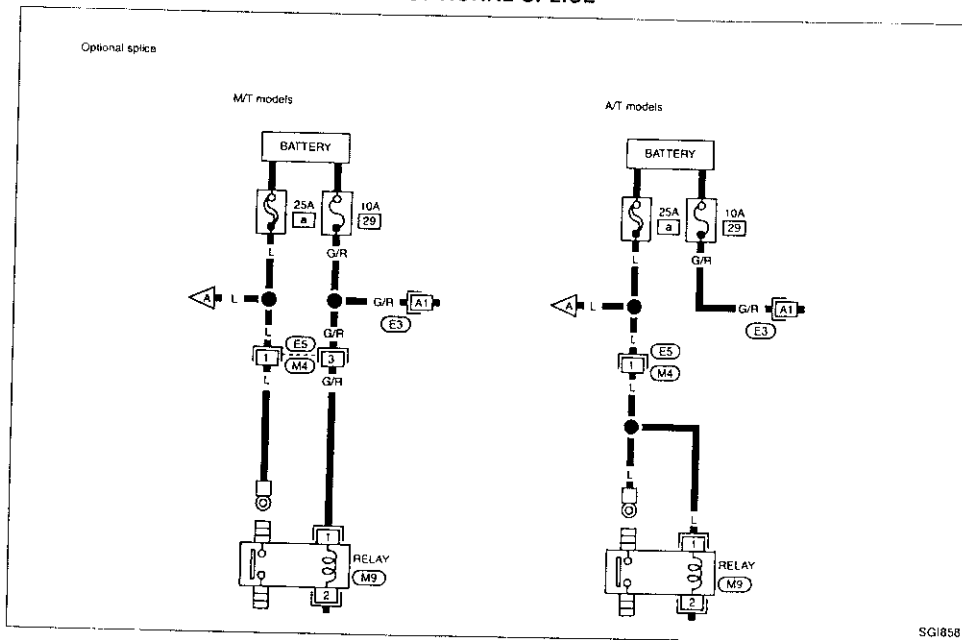

## HOW TO READ WIRING DIAGRAMS

#### Description

Number	Item	Description
1	Power condition	<ul style="list-style-type: none"> <li>This shows the condition when the system receives battery positive voltage (can be operated)</li> </ul>
2	Fusible link	<ul style="list-style-type: none"> <li>The double line shows that this is a fusible link</li> <li>The open circle shows current flow in and the shaded circle shows current flow out.</li> </ul>
3	Fusible link/fuse location	<ul style="list-style-type: none"> <li>This shows the location of the fusible link or fuse in the fusible link or fuse box See "POWER SUPPLY ROUTING" in EL section for arrangement.</li> </ul>
4	Fuse	<ul style="list-style-type: none"> <li>The single line shows that this is a fuse.</li> <li>The open circle shows current flow in and the shaded circle shows current flow out.</li> </ul>
5	Current rating	<ul style="list-style-type: none"> <li>This shows the current rating of the fusible link or fuse</li> </ul>
6	Connectors	<ul style="list-style-type: none"> <li>This shows that connector (E3) is female and connector (M1) is male.</li> <li>The G/R wire is located in the A1 terminal of both connectors</li> <li>Terminal No. with an alphabet (A1, B5, etc.) indicates that the connector is SMJ connector. Refer to GI-16.</li> </ul>
7	System branch	<ul style="list-style-type: none"> <li>This shows that the system branches to another system identified by cell code (section and system)</li> </ul>
8	Optional splice	<ul style="list-style-type: none"> <li>The open circle shows that the splice is optional depending on vehicle application.</li> </ul>
9	Splice	<ul style="list-style-type: none"> <li>The shaded circle shows that the splice is always on the vehicle.</li> </ul>
10	Page crossing	<ul style="list-style-type: none"> <li>This arrow shows that the circuit continues to an adjacent page</li> <li>The A will match with the A on the preceding or next page.</li> </ul>
11	Option abbreviation	<ul style="list-style-type: none"> <li>This shows that the circuit is optional depending on vehicle application.</li> </ul>
12	Switch	<ul style="list-style-type: none"> <li>This shows that continuity exists between terminals 1 and 2 when the switch is in the A position. Continuity exists between terminals 1 and 3 when the switch is in the B position.</li> </ul>
13	Page Crossing	<ul style="list-style-type: none"> <li>This arrow shows that the circuit continues to another page identified by cell code.</li> <li>The C will match with the C on another page within the system other than the next or preceding pages.</li> </ul>
14	Relay	<ul style="list-style-type: none"> <li>This shows an internal representation of the relay. See "STANDARDIZED RELAY" in EL section for details.</li> </ul>
15	Connectors	<ul style="list-style-type: none"> <li>This shows that the connector is connected to the body or a terminal with bolt or nut.</li> </ul>
16	Component name	<ul style="list-style-type: none"> <li>This shows the name of a component.</li> </ul>
17	Component box in wave line	<ul style="list-style-type: none"> <li>This shows that another part of the component is also shown on another page (indicated by wave line) within the system</li> </ul>
18	Assembly parts	<ul style="list-style-type: none"> <li>Connector terminal in component shows that it is a harness incorporated assembly</li> </ul>
19	Connector number	<ul style="list-style-type: none"> <li>This shows the connector number.</li> <li>The letter shows which harness the connector is located</li> <li>Example: M: main harness. See "HARNESS LAYOUT" in EL section to locate the connector A coordinate grid is included for complex harnesses to aid in locating connectors</li> </ul>



ORD

air procedures for the

efficient functioning of the  
hly. It is especially impor-  
ton be completely under-

re latest product informa-  
reserved to make changes  
without notice.

### NOTICE

Use for both the safety of  
the vehicle.  
are described in such a  
safely and accurately.  
e skills of the technician  
ly, anyone using service  
fficially recommended by  
If that neither his safety  
by the service method

CO., LTD.

ent

## GENERAL INFORMATION

# SECTION GI

## CONTENTS

<b>PRECAUTIONS</b> .....	2	<b>HOW TO FOLLOW FLOW CHART IN TROUBLE</b> .....	29
Precautions for Supplemental Restraint		<b>DIAGNOSES</b> .....	29
System "AIR BAG" and "SEAT BELT PRE-		<b>CONSULT CHECKING SYSTEM</b> .....	32
TENSIONER".....	2	Function and System Application.....	32
General Precautions.....	2	Lithium Battery Replacement.....	32
Precautions for Multiport Fuel Injection		Checking Equipment.....	32
System or ECOS Engine.....	4	<b>IDENTIFICATION INFORMATION</b> .....	33
Precautions for Three Way Catalyst.....	4	Model Variation.....	33
Precautions for Turbocharger.....	4	Identification Number.....	34
Engine Oils.....	5	Dimensions.....	37
Precautions for Fuel.....	6	Wheels and Tires.....	37
<b>HOW TO USE THIS MANUAL</b> .....	7	<b>LIFTING POINTS AND TOW TRUCK TOWING</b> .....	38
<b>HOW TO READ WIRING DIAGRAMS</b> .....	9	Garage Jack and Safety Stand.....	38
Sample Wiring Diagram — EXAMPL —.....	9	2-pole Lift.....	39
Description.....	11	Preparation.....	39
Wiring Diagram Codes (Cell Codes).....	17	Board-on Lift.....	39
<b>HOW TO PERFORM EFFICIENT DIAGNOSIS FOR</b>		Tow Truck Towing.....	40
<b>AN ELECTRICAL INCIDENT</b> .....	18	<b>TIGHTENING TORQUE OF STANDARD BOLTS</b> .....	41
Work Flow.....	18	<b>SAE J1930 TERMINOLOGY LIST</b> .....	42
Incident Simulation Tests.....	19	SAE J1930 Terminology List.....	42
Circuit Inspection.....	23		

GI  
MA  
EM  
LC  
EC  
FE  
CL  
MT  
AT  
PD  
FA  
RA  
BR  
ST  
RS  
BT  
HA  
EL  
DX

## HOW TO READ WIRING DIAGRAMS

### Description (Cont'd)

Number	Item	Description																
20	Wire color	<ul style="list-style-type: none"> <li>This shows a code for the color of the wire.</li> </ul> <table border="0"> <tr> <td>B = Black</td> <td>BR = Brown</td> </tr> <tr> <td>W = White</td> <td>OR = Orange</td> </tr> <tr> <td>R = Red</td> <td>P = Pink</td> </tr> <tr> <td>G = Green</td> <td>PU = Purple</td> </tr> <tr> <td>L = Blue</td> <td>GY = Gray</td> </tr> <tr> <td>Y = Yellow</td> <td>SB = Sky Blue</td> </tr> <tr> <td>LG = Light Green</td> <td>CH = Dark Brown</td> </tr> <tr> <td></td> <td>DG = Dark Green</td> </tr> </table> <p>When the wire color is striped, the base color is given first, followed by the stripe color as shown below: Example: L/W = Blue with White Stripe</p>	B = Black	BR = Brown	W = White	OR = Orange	R = Red	P = Pink	G = Green	PU = Purple	L = Blue	GY = Gray	Y = Yellow	SB = Sky Blue	LG = Light Green	CH = Dark Brown		DG = Dark Green
B = Black	BR = Brown																	
W = White	OR = Orange																	
R = Red	P = Pink																	
G = Green	PU = Purple																	
L = Blue	GY = Gray																	
Y = Yellow	SB = Sky Blue																	
LG = Light Green	CH = Dark Brown																	
	DG = Dark Green																	
21	Common component	<ul style="list-style-type: none"> <li>Connectors enclosed in broken line show that those belong to the same component.</li> </ul>																
22	Common connector	<ul style="list-style-type: none"> <li>The dotted lines between terminals show that these terminals are part of the same connector.</li> </ul>																
23	Current flow arrow	<ul style="list-style-type: none"> <li>Arrow indicates electric current flow, especially where the direction of standard flow (vertically downward or horizontally from left to right) is difficult to follow.</li> <li>A double arrow "◄ ►" shows that current can flow in either direction depending on circuit operation.</li> </ul>																
24	Option description	<ul style="list-style-type: none"> <li>This shows a description of the option abbreviation used on the page.</li> </ul>																
25	Ground	<ul style="list-style-type: none"> <li>This shows the ground connection.</li> </ul>																
26	Connector views	<ul style="list-style-type: none"> <li>This area shows the connector faces of the components in the wiring diagram on the page.</li> </ul>																
27	Fusible link and fuse box	<ul style="list-style-type: none"> <li>This shows the arrangement of fusible link(s) and fuse(s), used for connector views of POWER SUPPLY ROUTING in "EL" section.</li> <li>The open square shows current flow in, and the shaded square shows current flow out. Same meanings as the open and shaded circles in Number 2 and 4 above.</li> </ul>																
28	Reference	<ul style="list-style-type: none"> <li>This shows that more information on the Super Multiple Junction (SMJ) and joint connectors exists. See Foldout Page in EL section for details.</li> </ul>																
29	Shielded line	<ul style="list-style-type: none"> <li>The line enclosed by broken line circle shows shield wire.</li> </ul>																
30	Connector color	<ul style="list-style-type: none"> <li>This shows the code for the color of the connector. For code meaning, refer to wire color codes above (20).</li> </ul>																
31	Cell code	<ul style="list-style-type: none"> <li>This identifies each page of the wiring diagram by section, system and wiring diagram page number.</li> </ul>																
32	Ground	<ul style="list-style-type: none"> <li>The line spliced and grounded under wire color shows that ground line is spliced at the grounded connector.</li> </ul>																

## HOW TO READ WIRING DIAGRAMS

### Description (Cont'd)

#### CONNECTOR SYMBOLS

Most of connector symbols in wiring diagrams are shown from the terminal side.

- Connector symbols shown from the terminal side are enclosed by a single line.
- Connector symbols shown from the harness side are enclosed by a double line and followed by the direction mark

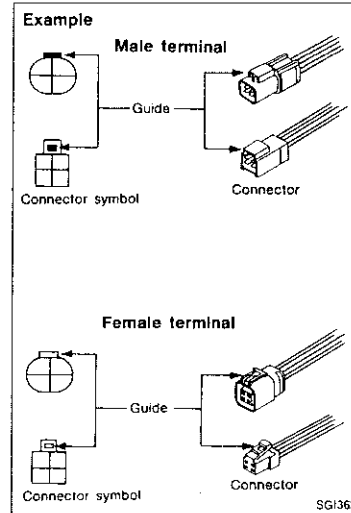
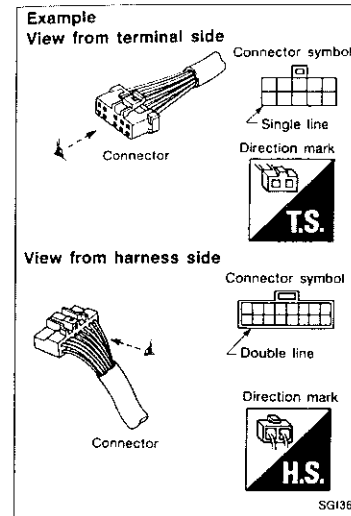

- Male and female terminals
- Connector guides for male terminals are shown in black and female terminals in white in wiring diagrams.

## HOW TO READ WIRING DIAGRAMS

### Description (Cont'd)

#### SWITCH POSITIONS

Switches are shown in wiring diagrams as if the vehicle is in the "normal" condition.

A vehicle is in the "normal" condition when:

- ignition switch is "OFF";
- doors, hood and trunk lid/back door are closed,
- pedals are not depressed, and
- parking brake is released.

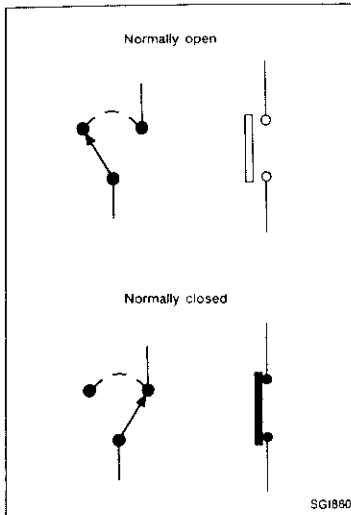

SG1890

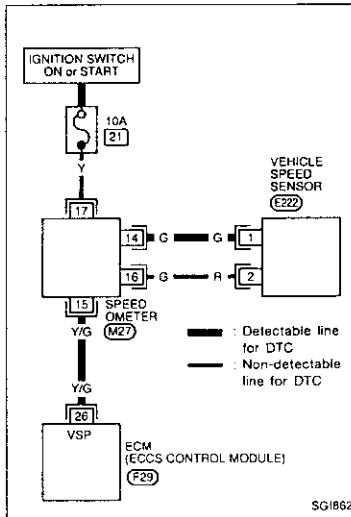

SG1892

#### DETECTABLE LINES AND NON-DETECTABLE LINES

In some wiring diagrams, two kinds of lines, representing wires, with different weight are used.

- A line with regular weight (wider line) represents a "detectable line for DTC (Diagnostic Trouble Code)". A "detectable line for DTC" is a circuit in which ECM (ECSS control module) can detect its malfunctions with the on-board diagnostic system.
- A line with less weight (thinner line) represents a "non-detectable line for DTC". A "non-detectable line for DTC" is a circuit in which ECM cannot detect its malfunctions with the on-board diagnostic system.

## HOW TO READ WIRING DIAGRAMS

### Description (Cont'd)

#### MULTIPLE SWITCH

The continuity of multiple switch is described in two ways as shown below.

- The switch chart is used in schematic diagrams.
- The switch diagram is used in wiring diagrams.

#### Example

(SWITCH CHART)

WIPER SWITCH		OFF	INT	LO	HI	WASH
1						○
2				○		
3	○	○	○			
4	○					
5		○	○			
6				○	○	○

(SWITCH DIAGRAM)

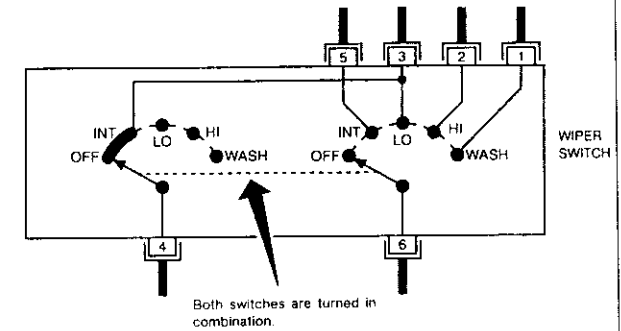

Both switches are turned in combination.

Continuity circuit of wiper switch

SWITCH POSITION	CONTINUITY CIRCUIT
OFF	3 - 4
INT	3 - 4, 5 - 6
LO	3 - 6
HI	2 - 6
WASH	1 - 6

SG1875

## HOW TO READ WIRING DIAGRAMS

### Description (Cont'd)

#### FOLDOUT PAGE

The foldout should be spread to read the entire wiring diagram.

#### Super multiple junction (SMJ)

In wiring diagram, connectors consisting of terminals having terminal numbers with an alphabet (B1, D0, etc.) are SMJ connectors.

If connector numbers are shown in Reference Area, these connector symbols are not shown in Connector Area. For terminal arrangement of these connectors, refer to the fold-out page at the end of this manual.

#### Joint connector

Joint connector symbols are shown in Connector Area in the wiring diagram concerned. Fold-out page also carries inside wiring layout together with such joint connector symbols.

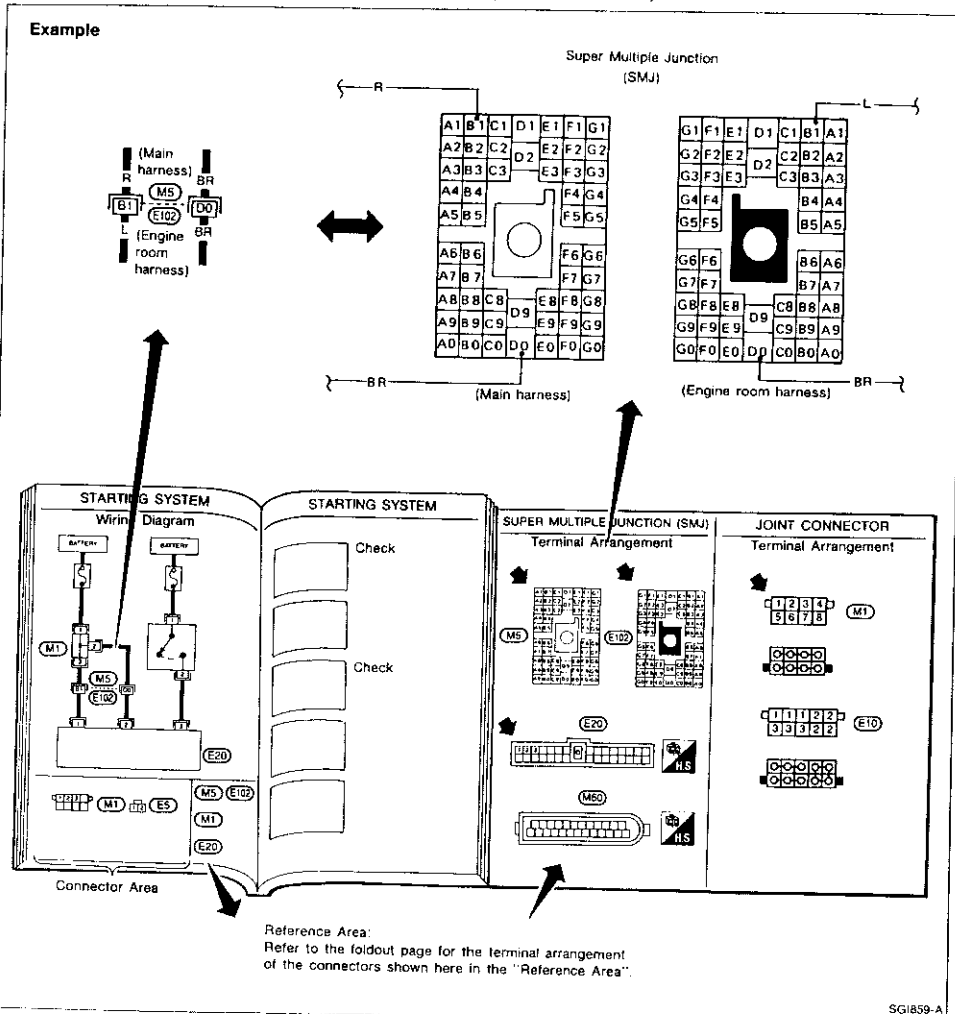

## HOW TO READ WIRING DIAGRAMS

### Wiring Diagram Codes (Cell Codes)

Use the chart below to find out what each wiring diagram code stands for.

Code	Section	Wiring Diagram Name
AAC/V	EC	IACV-AAC Valve
ABS	BR	Anti-lock Brake System
A/C, A	HA	Auto Air Conditioner
A/C, M	HA	Manual Air Conditioner
A/T	AT	Automatic Transmission
AIM	EL	Headlamp System
AT/C	EC	A/T Control
AUDIO	EL	Audio
BACK/L	EL	Back-up Lamp
BOOST	EC	Boost Pressure Sensor
CHARGE	EL	Charging System
CHIME	EL	Warning Chime
CMPS	EC	Camshaft Position Sensor
COOL/F	EC	Cooling Fan Control
DEF	EL	Rear Window Defogger
DEF/S	EC	Rear Window Defogger Signal
DIFF	PD	Differential Oil Cooler
D/LOCK	EL	Power Door Lock
DTRL	EL	Headlamp - With Daytime Light System
ECTS	EC	Engine Coolant Temperature Sensor
EGRC/V	EC	EGR and canister Control Solenoid Valve
F/FOG	EL	Front Fog Lamp
FICD	EC	IACV-FICD Solenoid Valve
F/PUMP	EC	Fuel Pump
H/LAMP	EL	Headlamp—Without Daytime Light System
H/SEAT	EL	Heated Seat
HEAT	HA	Heater
HLC	EL	Headlamp Washer
HO2S	EC	Heated Oxygen Sensor
HORN	EL	Horn, Cigarette Lighter, Clock
IGN/SG	EC	Ignition Signal
ILL	EL	Illumination
INJECT	EC	Injector
INT/L	EL	Interior, Spot and Trunk Room Lamps
KS	EC	Knock Sensor

Code	Section	Wiring Diagram Name
MAFS	EC	Mass Air Flow Sensor
MAIN	EC	Main Power Supply and Ground Circuit
METER	EL	Speedometer, Tachometer, Temp and Fuel Gauges
MIL	EC	MIL, Data Link Connector For Consult
MIRROR	EL	Door Mirror
MULTI	EL	Multi-remote Control System
P/ANT	EL	Power Antenna
PNP/SW	EC	Park/Neutral Position Switch
POWER	EL	Power Supply Routing
PST/SW	EC	Power Steering Oil Pressure Switch
R/FOG	EL	Rear Fog Lamp
SROOF	EL	Sun Roof
SRS	RS	Supplemental Restraint System
S/SIG	EC	Start Signal
START	EL	Starting System
STOP/L	EL	Stop Lamp
TAIL/L	EL	Clearance, License, and Tail Lamps
THEFT	EL	Theft Warning System
TPS	EC	Throttle Position Sensor
TURN	EL	Turn Signal and Hazard Warning Lamps
VSS	EC	Vehicle Speed Sensor
VTC	EC	VTC Solenoid Valve
WARN	EL	Warning Lamps
WG/V	EC	Wastegate Valve Control Solenoid Valve
WINDOW	EL	Power Window
WIPER	EL	Front Wiper and Washer
WIP/R	EL	Rear Wiper and Washer

Incident Simulation Tests

symptom is not present when the vehicle is brought in for service. Therefore, it is necessary to determine the conditions and environment when the incident occurred. Otherwise, only a No Fault Found diagnosis may be found. The following section illustrates ways to simulate the conditions/environment in which the owner experiences an electrical incident.

Broken into the six following topics:

1. Location

2. Time

3. Description of the incident from the customer. It is important for simulating the conditions/environment.

4. VIBRATION

5. Occur or become worse while driving on a rough road or when engine is vibrating. In such a case, you will want to check for a vibration related condition. Refer to the following section.

6. WIRING

Check connectors and wiring harness would affect the electrical system you are inspecting. Check each connector and harness while monitoring the system for the incident you are trying to reproduce. A test may indicate a loose or poor electrical connection.

Check for corrosion. If exposed to moisture. It is possible to get a thin film of corrosion on the connector terminals. A visual inspection may not reveal this without disconnecting the connector. If the problem is not resolved, perhaps the problem is caused by corrosion. It is a good idea to disconnect, inspect terminals on related connectors in the system.

5. Apply light vibration to sensors and relays in the system you are inspecting. This may indicate a loose or poorly mounted sensor or relay.

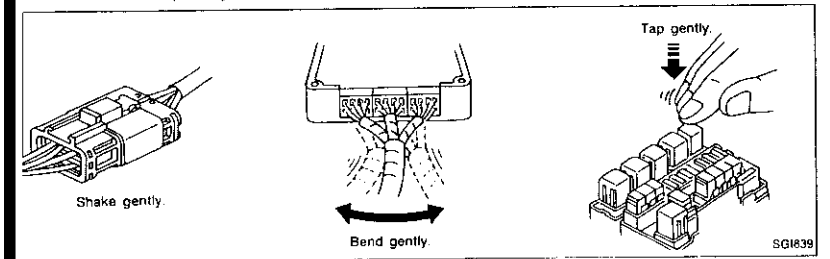

GI

MA

EM

LC

EC

FE

CL

MT

AT

PD

FA

RA

BR

ST

RS

BT

HA

EL

IDX



The strands sing  
ING

SGI840

contact  
mittent  
are not  
limeter  
cases  
arness  
ligator  
"T" pin  
bing a  
nciden-

## HOW TO PERFORM EFFICIENT DIAGNOSIS FOR AN ELECTRICAL INCIDENT

### Incident Simulation Tests (Cont'd)

#### Engine compartment

There are several reasons a vehicle or engine vibration could cause an electrical complaint. Some of the things to check for are:

- Connectors which are inaccessible for diagnosis probing.
- Connectors which may not fully be seated.
- Wiring harness which are not long enough and are being stressed during engine vibrations or rocking.
- Wires laying across brackets or moving components.
- Loose, dirty or corroded ground wires.
- Wires routed too close to hot components.

To inspect components under the hood, start by verifying the integrity of ground connections. (Refer to GROUND INSPECTION described later.) First check that the system is properly grounded. Then check for loose connection by **gently shaking** the wiring or components as previously explained. Using the wiring diagrams inspect the wiring for continuity.

#### Behind the instrument panel

Improperly routed or improperly clamped harness can become pinched during accessory installation. Vehicle vibration can aggravate a harness which is routed along a bracket or near a screw behind or below the dash.

#### Under seating areas

An unclamped or loose harness can cause wiring to be pinched by seat components (such as slide guides) during vehicle vibration. If the wiring runs under seating areas inspect wire routing for possible damage or pinching.

### HEAT SENSITIVE

The owner's problem may occur during hot weather or after car has sat for a short time. In such cases you will want to check for a heat sensitive condition.

To determine if an electrical component is heat sensitive, heat the component with a heat gun or equivalent.

**Do not heat components above 60°C (140°F).** If incident occurs while heating the unit, either replace or properly insulate the component.

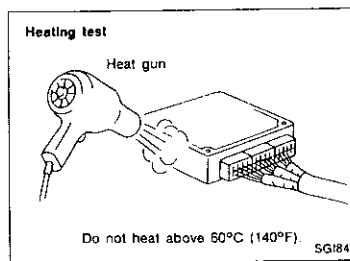

# MAINTENANCE

# SECTION MA

## CONTENTS

<b>PRECAUTIONS AND PREPARATION</b> .....	2	<b>CHASSIS AND BODY MAINTENANCE</b> .....	19
Supplemental Restraint System (SRS) "AIR BAG" and "SEAT BELT PRE-TENSIONER".....	2	Checking Exhaust System.....	19
Special Service Tools.....	2	Checking Clutch Fluid Level and Leaks.....	19
Commercial Service Tool.....	2	Checking Clutch System.....	19
<b>PRE-DELIVERY INSPECTION ITEMS</b> .....	3	Checking M/T Oil.....	19
<b>GENERAL MAINTENANCE</b> .....	4	Changing M/T Oil.....	19
<b>PERIODIC MAINTENANCE (Except for Europe)</b> .....	5	Checking A/T Fluid.....	20
<b>PERIODIC MAINTENANCE (For Europe)</b> .....	7	Changing A/T Fluid.....	20
<b>RECOMMENDED FLUIDS AND LUBRICANTS</b> .....	10	Checking Propeller Shaft.....	20
Fluids and Lubricants.....	10	Checking Differential Gear Oil.....	21
SAE Viscosity Number.....	11	Changing Differential Gear Oil.....	21
<b>ENGINE MAINTENANCE</b> .....	12	Balancing Wheels.....	21
Checking Drive Belts.....	12	Tire Rotation.....	21
Changing Engine Coolant.....	12	Checking Brake Fluid Level and Leaks.....	21
Checking Cooling System.....	13	Checking Brake Lines and Cables.....	21
Checking Fuel Lines.....	14	Changing Brake Fluid.....	22
Changing Fuel Filter.....	14	Checking Brake Booster, Vacuum Hoses, Connections and Check Valve.....	22
Changing Air Cleaner Filter.....	15	Checking Disc Brake.....	22
Changing Engine Oil.....	15	Checking Steering Gear and Linkage.....	23
Changing Oil Filter.....	16	Checking Power Steering Fluid and Lines.....	23
Changing Spark Plugs.....	16	Lubricating Locks, Hinges and Hood Latches.....	24
Checking Positive Crankcase Ventilation (PCV) System.....	17	Checking Seat Belts, Buckles, Retractors, Anchors and Adjusters.....	24
Checking Vacuum Hoses and Connections.....	17	<b>SERVICE DATA AND SPECIFICATIONS (SDS)</b> .....	25
Checking Vapor Lines.....	17	Engine Maintenance.....	25
Checking Heated Oxygen Sensor (HO2S).....	18	Chassis and Body Maintenance.....	25

GI

MA

EM

LC

EC

FE

CL

MT

AT

PD

FA

RA

BR

ST

RS

BT

HA

EL

IDX

## PRECAUTIONS AND PREPARATION



### Supplemental Restraint System (SRS) "AIR BAG" and "SEAT BELT PRE-TENSIONER"

The Supplemental Restraint System "Air Bag" and "Seat belt pre-tensioner", used along with a seat belt, help to reduce the risk or severity of injury to the driver and front passenger in a frontal collision. The Supplemental Restraint System consists of air bag modules (located in the center of the steering wheel and on the instrument panel on the passenger side), seat belt pre-tensioner, a diagnosis sensor unit, warning lamp, wiring harness and spiral cable. Information necessary to service the system safely is included in the RS section of this Service Manual.

#### WARNING:

- To avoid rendering the SRS inoperative, which could increase the risk of personal injury or death in the event of a collision which would result in air bag inflation, all maintenance must be performed by an authorized NISSAN dealer.
- Improper maintenance, including incorrect removal and installation of the SRS, can lead to personal injury caused by unintentional activation of the system.
- All SRS electrical wiring harnesses and connectors are covered with yellow outer insulation. Do not use electrical test equipment on any circuit related to the SRS.

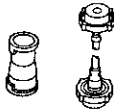
### Special Service Tools

Tool number Tool name	Description
EG17650301 Radiator cap tester adapter	 NT053
KV10115800 Oil filter wrench 65 mm (2.56 in) dia.	 NT006

### Commercial Service Tool

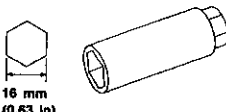
Tool name	Description
Spark plug wrench	 16 mm (0.63 in) Wrench with a magnet to hold spark plug NT047

## PRE-DELIVERY INSPECTION ITEMS

Shown below are Pre-delivery Inspection Items required for the new vehicle. It is recommended that necessary items other than those listed here be added, paying due regard to the conditions in each country.

Perform applicable items on each model. Consult text of this section for specifications.

### UNDER HOOD — engine off

- Radiator coolant level and coolant hose connections for leaks
- Battery fluid level, specific gravity and conditions of battery terminals
- Drive belts tension
- Fuel filter for water or dusts, and fuel lines and connections for leaks
- Engine oil level and oil leaks
- Clutch and brake reservoir fluid level and fluid lines for leaks
- Windshield and rear window washer and headlamp cleaner reservoir fluid level
- Power steering reservoir fluid level and hose connections for leaks

### ON INSIDE AND OUTSIDE

- Remove front spring/strut spacer (If applicable)
- Operation of all instruments, gauges, lights and accessories
- Operation of horn(s), wiper and washer
- Steering lock for operation
- Check air conditioner for gas leaks
- Front and rear seats, and seat belts for operation
- All moldings, trims and fittings for fit and alignment
- All windows for operation and alignment
- Hood, trunk lid, door panels for fit and alignment
- Latches, keys and locks for operation
- Weatherstrips for adhesion and fit
- Headlamp aiming
- Tighten wheel nuts (Inc. inner nuts if applicable)
- Tire pressure (Inc. spare tire)
- Check front wheels for toe-in
- Install clock/voltmeter/room lamp fuse (If applicable)
- Install deodorizing filter to air purifier (If applicable)
- Remove wiper blade protectors (If applicable)

### UNDER BODY

- Manual transmission/transaxle and differential gear oil level
- Brake and fuel lines and oil/fluid reservoirs for leaks
- Tighten bolts and nuts of steering linkage and gear box, suspension, propeller shafts and drive shafts
- Tighten rear body bolts and nuts (Models with wooden bed only)

### ROAD TEST

- Clutch operation
- Parking brake operation
- Service brake operation
- Automatic transmission/transaxle shift timing and kickdown
- Steering control and returnability
- Engine performance
- Squeaks and rattles

### ENGINE OPERATING AND HOT

- Adjust idle mixture and speed (and ignition timing\*1)
- Automatic transmission/transaxle fluid level
- Engine idling and stop knob operation (Diesel only)

### FINAL INSPECTION

- Install necessary parts (outside mirror, wheel covers, seat belts, mat, carpet or mud flaps)
- Inspect for interior and exterior metal and paint damage
- Check for spare tire, jack, tools (wheel chock), and literature
- Wash, clean interior and exterior

\*1: Not required on models with a direct ignition system

⊗: Not applicable on this model



## MAINTENANCE

It should be checked during the normal day-to-day vehicle is to continue operating properly. The owners or they can have their NISSAN dealers do them for

	Reference pages
Time to time, unless otherwise	
at a service station, including the check carefully for damage, cuts or	—
not wipe properly.	—
of the trunk lid and back door operate if necessary. Make sure that primary latch is released. When driving check for lubrication frequently.	MA-24
miles).	MA-21
regular basis, such as when perform-	
Turn signal lights, and other lights headlight aim.	—
and chimes are operating properly.	—
such as excessive free play, hard	—
sockets, anchors, adjusters and securely. Check the belt webbing for	MA-24
usually e.g. each time you check the	
the tank.	—
is cold.	MA-12
oil level spot and turning off the	MA-15
oil level fluid level is between the	MA-19, 21
on the "MAX" and "MIN" lines.	—

## PERIODIC MAINTENANCE (Except for Europe)

The following tables show the normal maintenance schedule. Depending upon weather and atmospheric conditions, varying road surfaces, individual driving habits and vehicle usage, additional or more frequent maintenance may be required.

Periodic maintenance beyond the last period shown on the tables requires similar maintenance.

MAINTENANCE OPERATION	MAINTENANCE INTERVAL										Reference page
	km x 1,000	1	10	20	30	40	50	60	70	80	
	(Miles x 1,000)	(0.6)	(6)	(12)	(18)	(24)	(30)	(36)	(42)	(48)	
Perform either at number of kilometers (miles) or months, whichever comes first	Months	—	6	12	18	24	30	36	42	48	
<b>ENGINE AND EMISSION CONTROL Underhood and under vehicle</b>											
Check drive belts for cracks, fraying, wear & tension						X				X	MA-12
Change engine anti-freeze coolant (Ethylene glycol base) (LLC)						X				X	MA-12
Check cooling system			X		X		X		X		MA-13
Check fuel lines						X			X		MA-14
Replace air cleaner filter (Viscous paper type)*						X			X		MA-15
Change engine oil (Use API SE, SF, SG or SH oil)*							Every 5,000 km (3,000 miles) or 6 months				MA-15
Change engine oil filter* (Use Part No. 15208-65F00)			X	X	X	X	X	X	X	X	MA-16
Replace fuel filter*						X				X	MA-15
Replace spark plugs (Use PLATINUM-TIPPED type)							Every 100,000 km (60,000 miles)				MA-16
Check vapor lines and heated oxygen sensor							X			X	MA-17, 18
<b>CHASSIS AND BODY Underhood</b>											
Check brake, clutch & automatic transmission fluid level & leaks*			X	X	X	X	X	X	X	X	MA-19, 20, 21
Change brake fluid*							X			X	MA-22
Check brake booster vacuum hoses, connections & check valve							X			X	MA-22
Check power steering fluid & lines			X	X	X	X	X	X	X	X	MA-23
<b>Under vehicle</b>											
Check brake, clutch & exhaust systems for proper attachment, leaks, cracks, chafing, abrasion, deterioration, etc.			X	X	X	X	X	X	X	X	MA-19, 21
Check oil level in manual transmission & differential gear*			X	X	X	X	X	X	X	X	MA-19, 21
Check steering gear & linkage, axle & suspension parts & propeller shaft & drive shaft for damaged, loose & missing parts & lubrication*			X		X			X		X	MA-20, 23 FA-5, RA-5, 7
<b>Outside and Inside</b>											
Check wheel alignment. If necessary, rotate & balance wheels						X		X		X	MA-21 FA-6
Check brake pads, discs & other brake components for wear, deterioration & leaks*			X	X	X	X	X	X	X	X	MA-22
Lubricate locks, hinges & hood latch*			X	X	X	X	X	X	X	X	MA-24
Check seat belts, buckles, retractors, anchors & adjuster						X		X		X	MA-24
Check foot brake, parking brake & clutch for free play, stroke & operation			X	X	X	X	X	X	X	X	CL-4, BR-7, 23
Air bag system							See NOTE (1).				RS-5

NOTE: (1) Inspect at the first 10 years and then every 2 years.

(2) Maintenance items with "\*" should be performed more frequently according to "Maintenance under severe driving conditions".

Check: Check. Correct or replace if necessary.

## PERIODIC MAINTENANCE (Except for Europe)

### MAINTENANCE UNDER SEVERE DRIVING CONDITIONS

The maintenance intervals shown on the preceding pages are for normal operating conditions. If the vehicle is mainly operated under severe driving conditions as shown below, more frequent maintenance must be performed on the following items as shown in the table.

#### Severe driving conditions

- A — Driving under dusty conditions
- B — Driving repeatedly short distances
- C — Towing a trailer
- D — Extensive idling
- E — Driving in extremely adverse weather conditions or in areas where ambient temperatures are either extremely low or extremely high
- F — Driving in high humidity areas or in mountainous areas
- G — Driving in areas using salt or other corrosive materials
- H — Driving on rough and/or muddy roads or in the desert
- I — Driving with frequent use of braking or in mountainous areas

Driving condition	Maintenance item	Maintenance operation	Maintenance interval	Reference page
A	Air cleaner filter	Replace		MA-15
A B C D	Engine oil	Replace	More frequently	MA-15
A B C D	Engine oil filter	Replace	Every 5,000 km (3,000 miles) or 3 months	MA-16
A	Fuel filter	Replace	Every 20,000 km (12,000 miles) or 12 months	MA-21
C	Automatic & manual transmission oil & differential gear oil	Replace	Every 40,000 km (24,000 miles) or 24 months	MA-19, 20, 21
G H	Steering gear & linkage, axle & suspension parts & propeller shaft & drive shafts	Check	Every 10,000 km (6,000 miles) or 6 months	MA-20, 23 FA-5, RA-5, 7
A C G H I	Brake pads, discs & other brake components	Check	Every 5,000 km (3,000 miles) or 3 months	MA-22
G	Lock, hinges & hood latch	Lubricate		MA-24

Maintenance operation: Check = Check. Correct or replace if necessary.

## PERIODIC MAINTENANCE (For Europe)

The following tables show the normal maintenance schedule. Depending upon weather and atmospheric conditions, varying road surfaces, individual driving habits and vehicle usage, additional or more frequent maintenance may be required.

Periodic maintenance beyond the last period shown on the tables requires similar maintenance.

### ENGINE OIL SERVICE

Abbreviations: R = Replace.

MAINTENANCE OPERATION	MAINTENANCE INTERVAL										Reference page
	km x 1,000	10	20	30	40	50	60	70	80	90	
Perform on kilometer basis or on month basis if not driven 10,000 km (6,000 miles) within a year.	(Miles x 1,000)	(6)	(12)	(18)	(24)	(30)	(36)	(42)	(48)	(54)	page
	Months	12	24	36	48	60	72	84	96		

[Engine oil service]	Engine compartment and under vehicle										Reference page
Engine oil (Use API SG or SH oil only)*	R	R	R	R	R	R	R	R	R	R	MA-15
Engine oil filter (Use Part No. 15208-65F00)*	R	R	R	R	R	R	R	R	R	R	MA-16

NOTE: (1) Maintenance items with "\*" should be performed more frequently according to "Maintenance under severe driving conditions".

### MAJOR SERVICE (Engine)

Abbreviations: R = Replace. I = Inspect. Correct or replace if necessary. [ ]: At the specified mileage only

MAINTENANCE OPERATION	MAINTENANCE INTERVAL						Reference page
	Months	12	24	36	48		
Perform on month basis or on kilometer basis if driven 30,000 km (18,000 miles) within a year.	km x 1,000	30	60	90	120		
	(Miles x 1,000)	(18)	(36)	(54)	(72)		

Underhood and under vehicle						
Drive belts	See NOTE (1).	I	I	I	I	MA-12
Engine anti-freeze coolant (Ethylene glycol base)	See NOTE (2).					MA-12
Cooling system		I	I	I	I	MA-13
Fuel lines			I		I	MA-14
Air cleaner filter (Viscous paper type)*			R		R	MA-15
Fuel filter*				R		MA-15
Spark plug (Use PLATINUM-TIPPED type)				[R]		MA-16
Heated oxygen sensor (Except for Sweden)			I		I	MA-18
Vapor lines	See NOTE (3).		I		I	MA-17

- NOTE: (1) After 24 months or 60,000 km (36,000 miles), check every 12 months or 30,000 km (18,000 miles).  
 (2) Change at 60 months or 90,000 km (54,000 miles), then every 24 months or 60,000 km (36,000 miles).  
 (3) For Sweden perform at the first 90,000 km (54,000 miles), and then every 60,000 km (36,000 miles) or 24 months, whichever comes first.  
 (4) Maintenance items with "\*" should be performed more frequently according to "Maintenance under severe driving conditions".

## PERIODIC MAINTENANCE (For Europe)

### MAJOR SERVICE (Chassis and Body)

Abbreviations: R = Replace. I = Inspect. Correct or replace if necessary.

MAINTENANCE OPERATION	MAINTENANCE INTERVAL				Reference page	
	Months	12	24	36		48
	km x 1,000 (Miles x 1,000)	30 (18)	60 (36)	90 (54)		120 (72)
<b>Underhood and under vehicle</b>						
Perform on month basis or on kilometer basis if driven 30,000 km (18,000 miles) within a year.						
Brake & clutch oil level & leak★	I	I	I	I	MA-19, 21	
Automatic transmission fluid (level & leakage)★	I	I	I	I	MA-20	
Brake fluid★			R		MA-22	
Brake booster vacuum hoses, connections & check valve			I		MA-22	
Power steering fluid & lines	I	I	I	I	MA-23	
Brake & clutch system	I	I	I	I	MA-19, 21	
Manual transmission & standard differential gear oil (For leakage)★	I	I	I	I	MA-19, 21	
Steering gear & linkage, axle & suspension parts, propeller shaft & drive shaft, exhaust system★			I		MA-20, 23 RA-5, 7, FA-5	
<b>Outside and inside</b>						
Wheel alignment (if necessary, rotate & balance wheels)	I	I	I	I	MA-21 FA-6	
Brake pads, discs & other brake components★	I	I	I	I	MA-22	
Headlamp aiming	I	I	I	I	EL-64	
Seat belts, buckles, retractors & adjuster	I	I	I	I	MA-24	
Foot brake, parking brake & clutch (For free play, stroke & operation)	I	I	I	I	CL-4 BR-7, 23	
Body corrosion	Annually					
Air bag system	See NOTE (1).				RS-5	

NOTE: (1) Inspect at the first 10 years and then every 2 years.

(2) Maintenance items with "★" should be performed more frequently according to "Maintenance under severe driving conditions".

## PERIODIC MAINTENANCE (For Europe)

### MAINTENANCE UNDER SEVERE DRIVING CONDITIONS

The maintenance intervals shown on the preceding pages are for normal operating conditions. If the vehicle is mainly operated under severe driving conditions as shown below, more frequent maintenance must be performed on the following items as shown in the table.

#### Severe driving conditions

- |  |  |
|--|--|
| <ul style="list-style-type: none"> <li>A — Driving under dusty conditions</li> <li>B — Driving repeatedly short distances</li> <li>C — Towing a trailer</li> <li>D — Extensive idling</li> <li>E — Driving in extremely adverse weather conditions or in areas where ambient temperature are either extremely low or extremely high</li> </ul> | <ul style="list-style-type: none"> <li>F — Driving in high humidity areas or in mountainous areas</li> <li>G — Driving in areas using salt or other corrosive materials</li> <li>H — Driving on rough and/or muddy roads or in the desert</li> <li>I — Driving with frequent use of braking or in mountainous areas</li> </ul> |
|--|--|

Driving condition		Maintenance item	Maintenance operation	Maintenance interval	Reference page			
<b>Engine oil service</b>								
A	B	C	D	Engine oil	Replace Every 5,000 km (3,000 miles) or 6 months MA-15			
A	B	C	D	Engine oil filter	Replace Every oil change MA-16			
<b>Major service</b>								
A				Air cleaner filter	Replace MA-15			
A				Fuel filter	Replace MA-16			
		F			Brake fluid	Replace Every 12 months or 30,000 km (18,000 miles) MA-21		
		G	H			Steering gear & linkage, axle & suspension parts, propeller shaft & drive shaft, exhaust system	Check MA-20, 23 FA-5, RA-5, 7	
		C			H	Automatic & manual transmission & differential gear oil	Replace Every 24 months or 60,000 km (36,000 miles) MA-19, 20, 21	
A	C			G	H	I	Brake pads, discs & other brake components	Check Every 6 months or 15,000 km (9,000 miles) MA-22

## RECOMMENDED FLUIDS AND LUBRICANTS

### Fluids and Lubricants

	Capacity (Approximate)		Recommended fluids and lubricants
	Liter	Imp measure	
Engine oil (Refill)			
With oil filter	3.7	3-1/4 qt	API SF/CC, SF/CD, SE, SG or SH*1
Without oil filter	3.5	3-1/8 qt	
Cooling system (with reservoir tank)	6.2	5-1/2 qt	Anti-freeze coolant (Ethylene glycol base) or soft water
Manual transmission oil	2.4	4-1/4 pt	API GL-4*
Differential carrier gear oil	1.8	3-1/8 pt	API GL-5*
Automatic transmission fluid	7.9	7 qt	Genuine Nissan ATF or equivalent*2
Power steering fluid	0.9	3/4 qt	Type DEXRON™
Brake and clutch fluid	—	—	For Europe DOT3 or DOT4 (US FMVSS No. 116)*3 Except for Europe DOT3 (US FMVSS No. 116)
Multi-purpose grease	—	—	NLGI No. 2 (Lithium soap base)

\*1: For further details, see "SAE Viscosity Number".

\*2: For more information regarding suitable fluids, contact a Nissan dealership.

\*3: Never mix different type fluids. (DOT3 and DOT4)

## RECOMMENDED FLUIDS AND LUBRICANTS

### SAE Viscosity Number

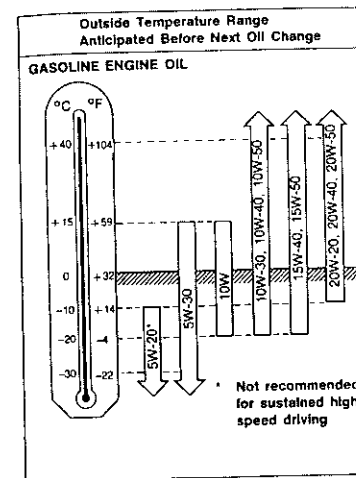

T10005

- 5W-30 or 10W-30 is preferable regardless of driving conditions.

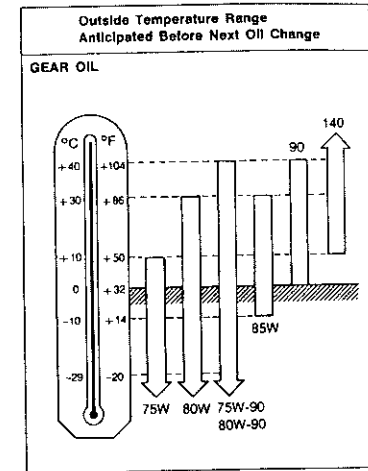

T10003

- For warm and cold areas: 75W-90 for transmission and 80W-90 for differential carrier are preferable.
- For hot areas: 90 is suitable for ambient temperatures below 40°C (104°F).

## ENGINE MAINTENANCE

### Changing Engine Coolant (Cont'd)

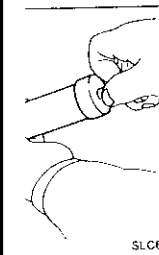
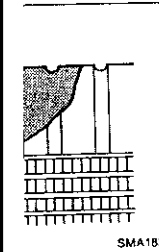
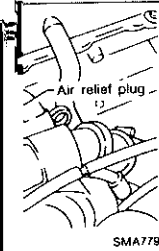

7. Warm up engine until cooling fan operates, then race engine 2 or 3 times under no-load.

● **Make sure that air conditioner switch is "OFF".**

8. Stop engine and wait until it cools down.

9. Repeat step 1 through step 8 until clear water begins to drain from radiator.

10. Drain water.

● **Apply sealant to the thread of drain plug.**

○: 8 - 12 N·m (0.8 - 1.2 kg-m, 5.8 - 8.7 ft-lb)

11. Reinstall reservoir tank.

12. Fill radiator and reservoir tank with coolant up to specified level following step 5 through step 8.

Follow instructions attached to anti-freeze container for mixing ratio of anti-freeze to water.

**Coolant capacity (With reservoir tank):**

**6.2 ℓ (5-1/2 Imp qt)**

[Reservoir tank capacity for "H" level is 1.8 ℓ (1-5/8 Imp qt).]  
**Pour coolant through coolant filler neck slowly to allow air in system to escape.**

13. If necessary, add coolant.

14. Start and warm up engine, then increase engine speed to 4,000 rpm. Check that radiator coolant level is not lowered, and that no water noise is heard in heater core. If water noise is heard, bleed air by referring to "Refilling Engine Coolant" in section LC.

### Checking Cooling System

#### CHECKING HOSES

Check hoses for improper attachment and for leaks, cracks, damage, loose connections, chafing and deterioration.

#### CHECKING RADIATOR CAP

Apply pressure to radiator cap with cap tester to see if it is satisfactory.

**Radiator cap relief pressure:**

78 - 98 kPa

(0.78 - 0.98 bar, 0.8 - 1.0 kg/cm<sup>2</sup>, 11 - 14 psi)

**Checking Cooling System (Cont'd)**

Pull the negative-pressure valve to open it. Check that it closes completely when released.

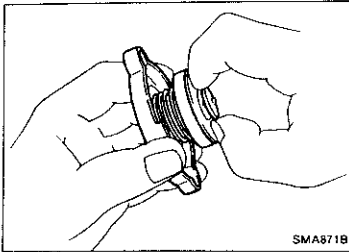

**CHECKING COOLING SYSTEM FOR LEAKS**

Apply pressure to the cooling system with cap tester to check for leakage.

**Testing pressure:**  
157 kPa (1.57 bar, 1.6 kg/cm<sup>2</sup>, 23 psi)

**CAUTION:**  
Higher pressure than the specified value may cause damage to radiator.

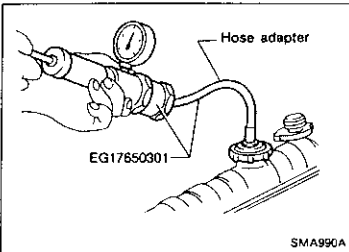

**Checking Fuel Lines**

Inspect fuel lines and tank for improper attachment and for leaks, cracks, damage, loose connections, chafing and deterioration.

If necessary, repair or replace faulty parts.

**CAUTION:**

Tighten high-pressure rubber hose clamp so that clamp end is 3 mm (0.12 in) from hose end.

Tightening torque specifications are the same for all rubber hose clamps.

Ensure that screw does not contact adjacent parts.

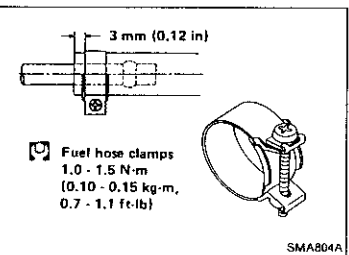

**Changing Fuel Filter**

**WARNING:**

Before removing fuel filter, release fuel pressure from fuel line to eliminate danger.

**Changing Fuel Filter (Cont'd)**

1. Remove fuse for fuel pump.
2. Start engine.
3. After engine stalls, crank engine two or three times to make sure that fuel pressure is released.
4. Turn ignition switch off and install fuse for fuel pump.

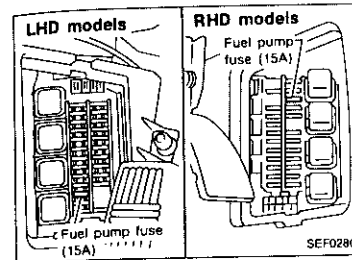

5. Loosen fuel hose clamps.
  6. Replace fuel filter.
- Be careful not to spill fuel over engine compartment. Place a shop towel to absorb fuel.
  - Use a high-pressure type fuel filter. Do not use a synthetic resinous fuel filter.
  - When tightening fuel hose clamps, refer to "Checking Fuel Lines".

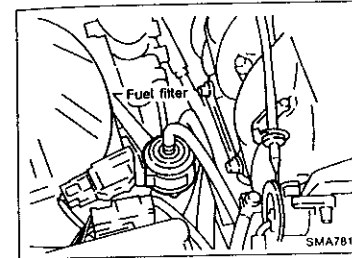

**Changing Air Cleaner Filter**

**Viscous paper type**

The viscous paper type filter does not need cleaning between renewals.

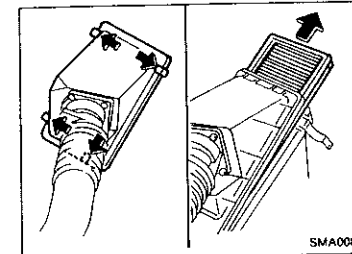

**Changing Engine Oil**

**WARNING:**

- Be careful not to burn yourself, as the engine oil is hot.
- Prolonged and repeated contact with used engine oil may cause skin cancer; try to avoid direct skin contact with used oil. If skin contact is made, wash thoroughly with soap or hand cleaner as soon as possible.

1. Warm up engine, and check for oil leakage from engine components.

2. Remove drain plug and oil filler cap.
3. Drain oil and refill with new engine oil.

**Refill oil capacity (Approximate):**

With oil filter change

3.7 ℓ (3-1/4 Imp qt)

Without oil filter change

3.5 ℓ (3-1/8 Imp qt)

**CAUTION:**

- Be sure to clean drain plug and install with new washer.
- Drain plug:**
- : 29 - 39 N·m (3.0 - 4.0 kg·m, 22 - 29 ft·lb)
  - Use recommended engine oil.

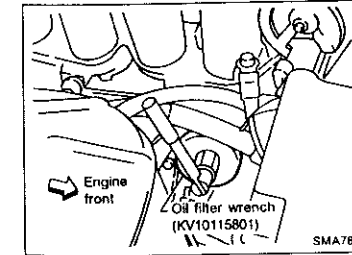

GI  
MA  
EM  
LC  
EC  
FE  
CL  
MT  
AT  
PD  
FA  
RA  
BR  
ST  
RS  
BT  
HA  
EL  
IDX

## TENANCE

### Spark Plugs (Cont'd)

and adjusting plug gap are not required between

use a wire brush for cleaning.

If the plug is covered with carbon, spark plug cleaner may

Use the following air pressure:

For air pressure: less than 588 kPa (5.9 bar, 6 kg/cm<sup>2</sup>, 85 psi)

For cleaning time:

For cleaning time: less than 20 seconds

### Positive Crankcase Ventilation (PCV)

#### CV valve

When the engine is running at idle, remove ventilation hose from PCV valve. If the valve is working properly, a hissing noise will be heard as air passes through it and a strong vacuum should be felt when a finger is placed over valve inlet.

### Vacuum Hoses and Connections

Inspect vacuum hoses for improper attachment and for leaks, damage, loose connections, chafing and deterioration.

### Vapor Lines

Inspect vapor lines for improper attachment and for leaks, damage, loose connections, chafing and deterioration.

Check the operation of the vacuum relief valve of fuel tank filler cap for proper operation, sticking, etc.

Refer to the "EVAPORATIVE EMISSION SYSTEM" in EC section

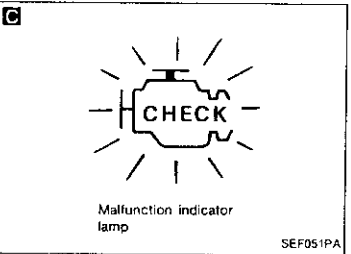
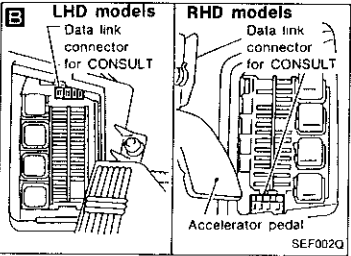
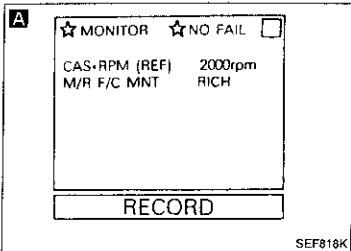

Checking Heated Oxygen Sensor (HO2S)

Checking procedure

INSPECTION START

Start engine and warm it up until water temperature indicator points to the middle of gauge.

- A E C**
- 1. See "M/R F/C MNT" in "Data monitor" mode.
- 2. Run engine at about 2,000 rpm for about 2 minutes under no-load.
- 3. Maintaining engine at 2,000 rpm under no-load (engine is warmed up sufficiently), check that the monitor fluctuates between "LEAN" and "RICH" more than 5 times during 10 seconds.
  - 1 time** RICH → LEAN → RICH
  - 2 times** RICH → LEAN → RICH → LEAN → RICH .....
  - OR .....

- 1. Set "Heated oxygen sensor monitor" in the Diagnostic test mode II. (Refer to EC section.)
- 2. Run engine at about 2,000 rpm for about 2 minutes under no-load.
- 3. Maintaining engine at 2,000 rpm under no-load, check to make sure that malfunction indicator lamp on the instrument panel goes ON and OFF more than 5 times during 10 seconds.

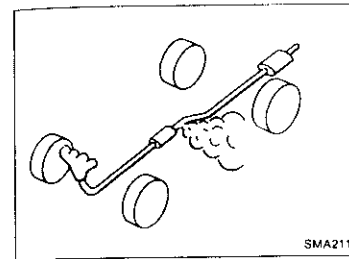
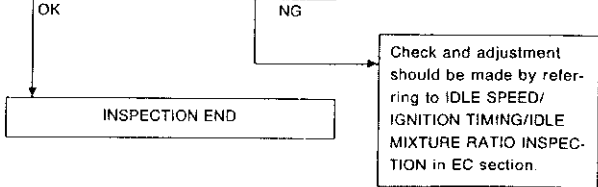

Checking Exhaust System

- Check exhaust pipes, muffler and mounting for improper attachment, leaks, cracks, damage, loose connections, chafing and deterioration.

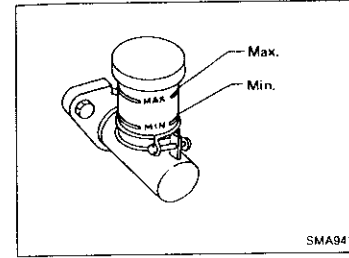

Checking Clutch Fluid Level and Leaks

- If fluid level is extremely low, check clutch system for leaks.

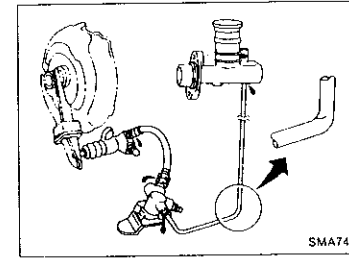

Checking Clutch System

Check fluid lines and operating cylinder for improper attachment, cracks, damage, loose connections, chafing and deterioration.

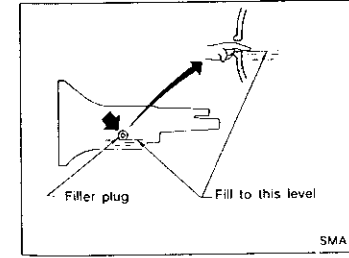

Checking M/T Oil

- Check oil level and for oil leakage.
- Never start engine while checking oil level.
- Filler plug:
  - [C]: 25 - 34 N·m (2.5 - 3.5 kg·m, 18 - 25 ft-lb)

Changing M/T Oil

1. Drain oil from drain plug and refill with new gear oil.
  2. Check oil level.
    - Oil grade: API GL-4
    - Viscosity: See "RECOMMENDED FLUIDS AND LUBRICANTS".
    - Capacity: 2.5 l (4-3/8 Imp pt)
    - Drain plug:
      - [C]: 25 - 34 N·m (2.5 - 3.5 kg·m, 18 - 25 ft-lb)
- After refilling oil, leave M/T unattended for about two minutes. Then check oil level again following the above procedure. Add oil if necessary.



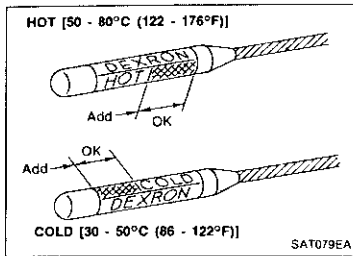

**Checking A/T Fluid**

1. Warm up engine.
2. Check for fluid leakage.
3. Before driving, fluid level can be checked at fluid temperatures of 30 to 50°C (86 to 122°F) using "COLD" range on dipstick.
  - a. Park vehicle on level surface and set parking brake.
  - b. Start engine and move selector lever through each gear position. Leave selector lever in "P" position.
  - c. Check fluid level with engine idling.
  - d. Remove dipstick and note reading. If level is at low side of either range, add fluid to the charging pipe.
  - e. Re-insert dipstick into charging pipe as far as it will go.
  - f. Remove dipstick and note reading. If reading is at low side of range, add fluid to the charging pipe. Do not overfill.
4. Drive vehicle for approximately 5 minutes in urban areas.
5. Re-check fluid level at fluid temperatures of 50 to 80°C (122 to 177°F) using "HOT" range on dipstick.
6. Check fluid condition. If fluid is very dark or smells burned, or contains friction material (clutches, band, etc.), check operation of A/T. Refer to AT section for checking operation of A/T.

**Changing A/T Fluid**

1. Warm up A/T fluid.
2. Stop engine.
3. Drain A/T fluid from drain plug and refill with new A/T fluid. Always refill same volume with drained fluid.
  - Oil grade:**  
Genuine Nissan ATF or equivalent.
  - Oil capacity (With torque converter):**  
7.9 l (7 Imp qt)
  - Drain plug:**  
⌚: 29 - 39 N·m (3.0 - 4.0 kg-m, 22 - 29 ft-lb)
4. Run engine at idle speed for five minutes.
5. Check fluid level and condition. Refer to "Checking A/T Fluid". If fluid is still dirty, repeat step 2. through 5.

**Checking Propeller Shaft**

Check propeller shaft and center bearing for damage, looseness or grease leakage. If greasing points are provided, supply grease as necessary. Refer to PD section.

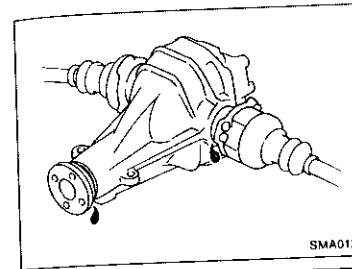
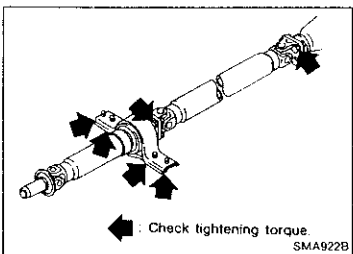

**Checking Differential Gear Oil**

- Check oil level and for oil leakage.
  - Filler plug:**  
⌚: 39 - 59 N·m (4 - 6 kg-m, 29 - 43 ft-lb)

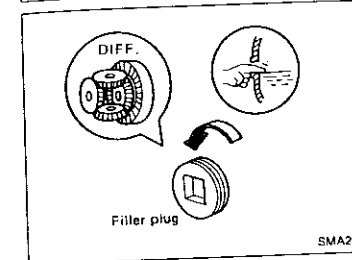

**Changing Differential Gear Oil**

1. Drain oil from drain plug and refill with new gear oil.
2. Check oil level.
  - Oil grade:** API GL-5
  - Viscosity:**  
See "RECOMMENDED FLUIDS AND LUBRICANTS".
  - Capacity:**  
1.2 - 1.4 l (2-1/8 - 2-1/2 Imp pt)
  - Drain plug:**  
⌚: 39 - 59 N·m (4 - 6 kg-m, 29 - 43 ft-lb)

**Balancing Wheels**

- Adjust wheel balance using road wheel center.
  - Wheel balance (Maximum allowable unbalance):**  
Refer to SDS (MA-25).

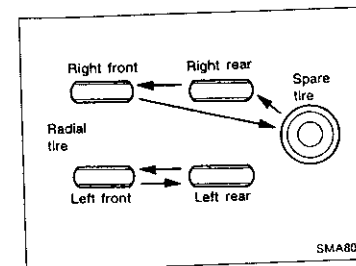

**Tire Rotation**

- Do not include the T-type spare tire when rotating the tires.
  - Wheel nuts:**  
⌚: 99 - 117 N·m (10.1 - 11.9 kg-m, 73.0 - 86.3 ft-lb)

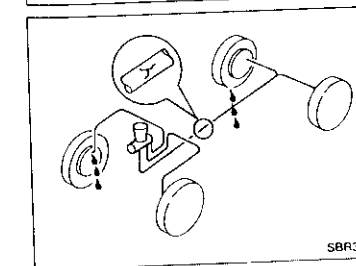

**Checking Brake Fluid Level and Leaks**

- If fluid level is extremely low, check brake system for leaks.

**Checking Brake Lines and Cables**

- Check brake fluid lines and parking brake cables for improper attachment, leaks, chafing, abrasions and deterioration, etc.

GL  
MA  
EM  
LC  
EC  
FE  
CL  
MT  
AT  
PD  
FA  
RA  
BR  
ST  
RE  
E  
R  
E

## D BODY MAINTENANCE

### Checking Steering Gear and Linkage

#### STEERING GEAR

- Check gear housing and boots for looseness, damage or grease leakage. **GI**
- Check connection with steering column for looseness. **MA**

#### STEERING LINKAGE

- Check ball joint, dust cover and other component parts for looseness, wear, damage or grease leakage. **EM**

### Checking Power Steering Fluid and Lines

#### CHECKING FLUID LEVEL

- Check fluid level with dipstick on reservoir cap. Use "HOT" range at fluid temperatures of 50 to 80°C (122 to 176°F). Use "COLD" range at fluid temperatures of 0 to 30°C (32 to 86°F). **EC**

#### CAUTION:

- Do not overfill. **PE**
- Recommended fluid is Automatic Transmission Fluid type "DEXRON™" or equivalent. **CL**

#### CHECKING LINES

- Check lines for improper attachment, leaks, cracks, damage, loose connections, chafing and deterioration. **MT**

**AT**

**PD**

**FA**

**RA**

**BR**

**ST**

**RS**

**BT**

**HA**

**EL**

**IDA**

Lubricating Locks, Hinges and Hood Latches

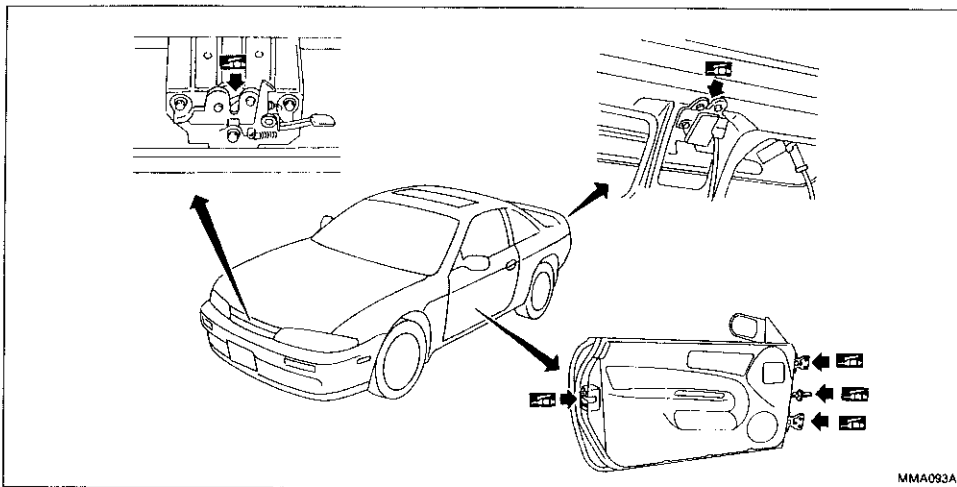

MMA093A

Checking Seat Belts, Buckles, Retractors, Anchors and Adjusters

CAUTION:

- After any collision, inspect all seat belt assemblies, including retractors and other attached hardware (i.e. guide rail set). Nissan recommends to replace all seat belt assemblies in use during a collision, unless not damaged and properly operating after minor collision.
- Also inspect seat belt assemblies not in use during a collision, and replace if damaged or improperly operating.
- If any component of seat belt assembly is questionable, do not repair. Replace as seat belt assembly.
- If webbing is cut, frayed, or damaged, replace belt assembly.
- Never oil tongue and buckle.
- Use a genuine seat belt assembly.

For seat belt pre-tensioner, refer to section RS.

Anchor bolt  
 43 - 55 N·m  
 (4.4 - 5.6 kg·m,  
 32 - 41 ft·lb)

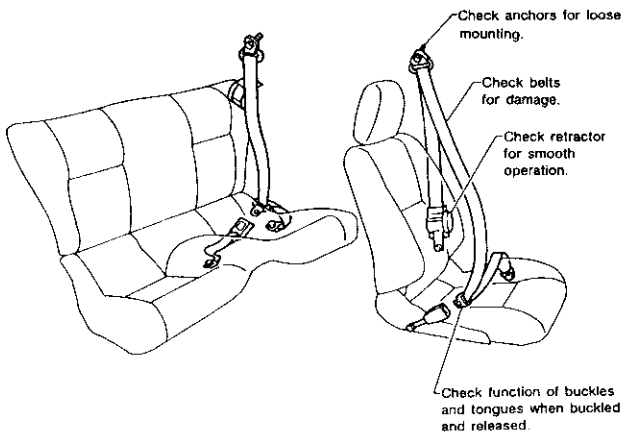

MMA094AA

Engine Maintenance

INSPECTION AND ADJUSTMENT

Drive belt deflection

	Used belt deflection		Deflection of new belt
	Limit	Deflection after adjustment	
Alternator	11 (0.43)	7 - 8 (0.28 - 0.31)	4 - 5 (0.16 - 0.20)
Air conditioner compressor	7 (0.28)	5 - 6 (0.20 - 0.24)	6 - 7 (0.24 - 0.28)
Power steering oil pump	15 (0.59)	11 - 12 (0.43 - 0.47)	9 - 10 (0.35 - 0.39)
Applied pushing force	98 N (10 kg, 22 lb)		

Unit: mm (in)

Coolant and oil capacity

	Unit: (Imp qt)
Coolant (with reservoir tank)	Approx. 7.0 (6-1/8)
Reservoir tank	1.8 (1-5/8)
Engine oil	
With oil filter change	Approx. 3.7 (3-1/4)
Without oil filter change	Approx. 3.5 (3-1/8)

INSPECTION AND ADJUSTMENT

Wheel balance

Maximum allowable unbalance	Dynamic (at rim flange)	10 (0.35) (One side)
	g (oz)	
	Static	20 (0.71)
	g (oz)	

Chassis and Body Maintenance

Brake

	Unit: mm (in)
Disc brake	
Pad	
Standard thickness	
OPF25V	10.0 (0.394)
CL11H	9.5 (0.374)
Minimum thickness	
OPF25V	2.0 (0.079)
CL11H	2.0 (0.079)
Rotor	
Standard thickness	
OPF25V	30.0 (1.181)
CL11H	9.0 (0.354)
Minimum thickness	
OPF25V	28.0 (1.102)
CL11H	8.0 (0.315)

Circuit Inspection

Circuit inspection is an easy task if it is approached in a logical and organized method. It is important to have all available information on the system to be tested. Also, get a complete history of system operation. Then you will be able to use the appropriate equipment and procedure. Gently shake the wiring and components while testing electrical components. Gently shake the wiring and component to do this.

When there is no continuity through a section of the circuit, you should check for the following types of shorts.

- When a circuit contacts another circuit and causes the normal resistance to change.
- When a circuit contacts a ground source and grounds the circuit.

WORKING IN THE CIRCUIT

Before you disconnect and test the system, you should rough sketch a schematic of the system. Then, carefully walk through the diagnosis process. Drawing the sketch will also reinforce your understanding of the system.

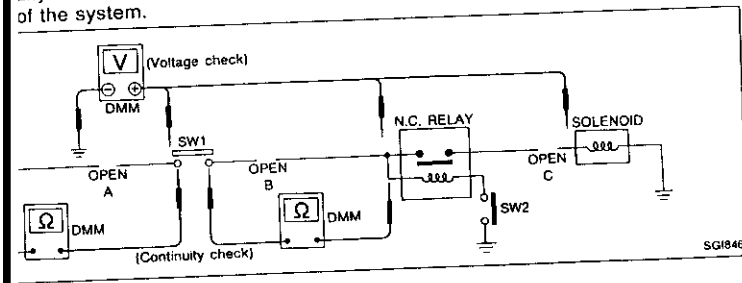

Use the DMM to find an open in the circuit. The Digital Multimeter (DMM) set on the resistance mode will indicate an open circuit as over limit (OL, no beep tone or no ohms symbol). Make sure the DMM is at the highest resistance level. For the diagnosis of open circuits please refer to the schematic above.

Start at the positive (red) negative cable. Work your way through the circuit and work your way to the other end. (At the fuse block in this example, start at the fuse block terminal on the load side.)

Probe the fuse block terminal on the load side of SW1. Little or no resistance will indicate good continuity. If there were an open in the circuit, the DMM would indicate an over limit or infinite resistance condition. (point A)

Probe between SW1 and the relay. Little or no resistance will indicate that portion of the circuit has good continuity. If there were an open in the circuit, the DMM would indicate an over limit or infinite resistance condition. (point B)

Probe between the relay and the solenoid. Little or no resistance will indicate that portion of the circuit has good continuity. If there were an open in the circuit, the DMM would indicate an over limit or infinite resistance condition. (point C)

Proceed with the diagnosis using the approach in the above example.

## HOW TO PERFORM EFFICIENT DIAGNOSIS FOR AN ELECTRICAL INCIDENT

### Circuit Inspection (Cont'd)

#### Voltage check method

To help in understanding the diagnosis of open circuits please refer to the previous schematic. In any powered circuit, an open can be found by methodically checking the system for the presence of voltage. This is done by switching the DMM to the voltage function.

1. Connect one probe of the DMM to a known good ground.
2. Begin probing at one end of the circuit and work your way to the other end.
3. With SW1 open, probe at SW1 to check for voltage.  
voltage; open is further down the circuit than SW1.  
no voltage; open is between fuse block and SW1 (point A).
4. Close SW1 and probe at relay.  
voltage; open is further down the circuit than the relay.  
no voltage; open is between SW1 and relay (point B).
5. Close the relay and probe at the solenoid.  
voltage; open is further down the circuit than the solenoid.  
no voltage; open is between relay and solenoid (point C).

Any powered circuit can be diagnosed using the approach in the above example.

#### TESTING FOR "SHORTS" IN THE CIRCUIT

To simplify the discussion of shorts in the system please refer to the schematic below.

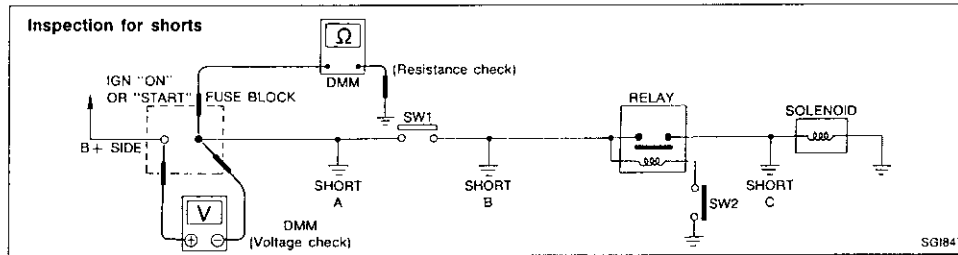

#### Resistance check method

1. Disconnect the battery negative cable and remove the blown fuse.
2. Disconnect all loads (SW1 open, relay disconnected and solenoid disconnected) powered through the fuse.
3. Connect one probe of the ohmmeter to the load side of the fuse terminal. Connect the other probe to a known good ground.
4. With SW1 open, check for continuity.  
continuity; short is between fuse terminal and SW1 (point A).  
no continuity; short is further down the circuit than SW1.
5. Close SW1 and disconnect the relay. Put probes at the load side of fuse terminal and a known good ground. Then, check for continuity.  
continuity; short is between SW1 and the relay (point B).  
no continuity; short is further down the circuit than the relay.
6. Close SW1 and jump the relay contacts with jumper wire. Put probes at the load side of fuse terminal and a known good ground. Then, check for continuity.  
continuity; short is between relay and solenoid (point C).  
no continuity; check solenoid, retrace steps.

#### Voltage check method

1. Remove the blown fuse and disconnect all loads (i.e. SW1 open, relay disconnected and solenoid disconnected) powered through the fuse.
2. Turn the ignition key to the ON or START position. Verify battery voltage at the B+ side of the fuse terminal (one lead on the B+ terminal side of the fuse block and one lead on a known good ground).
3. With SW1 open and the DMM leads across both fuse terminals, check for voltage.  
voltage; short is between fuse block and SW1 (point A).

## HOW TO PERFORM EFFICIENT DIAGNOSIS FOR AN ELECTRICAL INCIDENT

### Circuit Inspection (Cont'd)

- no voltage; short is further down the circuit than SW1.
4. With SW1 closed, relay and solenoid disconnected and the DMM leads across both fuse terminals, check for voltage.  
voltage; short is between SW1 and the relay (point B).  
no voltage; short is further down the circuit than the relay.
5. With SW1 closed, relay contacts jumped with fused jumper wire check for voltage.  
voltage; short is down the circuit of the relay or between the relay and the disconnected solenoid (point C).  
no voltage; retrace steps and check power to fuse block.

#### GROUND INSPECTION

Ground connections are very important to the proper operation of electrical and electronic circuits. Ground connections are often exposed to moisture, dirt and other corrosive elements. The corrosion (rust) can become an unwanted resistance. This unwanted resistance can change the way a circuit works.

Electronically controlled circuits are very sensitive to proper grounding. A loose or corroded ground can drastically affect an electronically controlled circuit. A poor or corroded ground can easily affect the circuit. Even when the ground connection looks clean, there can be a thin film of rust on the surface.

When inspecting a ground connection follow these rules:

1. Remove the ground bolt screw or clip.
2. Inspect all mating surfaces for tarnish, dirt, rust, etc.
3. Clean as required to assure good contact.
4. Reinstall bolt or screw securely.
5. Inspect for "add-on" accessories which may be interfering with the ground circuit.
6. If several wires are crimped into one ground eyelet terminal, check for proper crimps. Make sure all of the wires are clean, securely fastened and providing a good ground path. If multiple wires are cased in one eyelet make sure no ground wires have excess wire insulation.

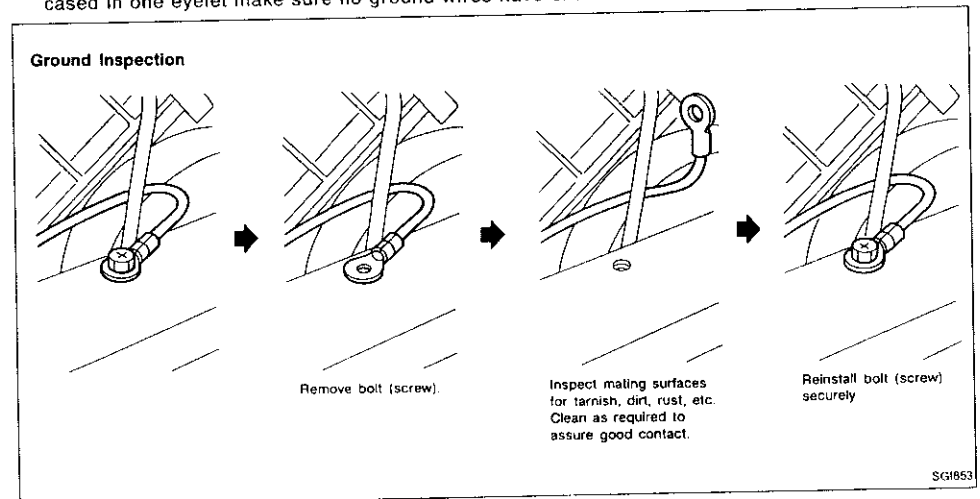

## HOW TO PERFORM EFFICIENT DIAGNOSIS FOR AN ELECTRICAL INCIDENT

### Circuit Inspection (Cont'd)

#### VOLTAGE DROP TESTS

Voltage drop tests are often used to find components or circuits which have excessive resistance. A voltage drop in a circuit is caused by a resistance **when the circuit is in operation**.

Check the wire in the illustration. When measuring resistance with ohmmeter, contact by a single strand of wire will give reading of 0 ohms. This would indicate a good circuit. When the circuit operates, this single strand of wire is not able to carry the current. The single strand will have a high resistance to the current. This will be picked up as a slight voltage drop.

Unwanted resistance can be caused by many situations as follows:

Undersized wiring (single strand example)

Corrosion on switch contacts

Loose wire connections or splices.

If repairs are needed always use wire that is of the same or larger gauge.

#### Measuring voltage drop — Accumulated method

1. Connect the voltmeter across the connector or part of the circuit you want to check. The positive lead of the voltmeter should be closer to power and the negative lead closer to ground.
2. Operate the circuit.
3. The voltmeter will indicate how many volts are being used to "push" current through that part of the circuit.

**Note in the illustration that there is an excessive 4.1 volt drop between the battery and the bulb.**

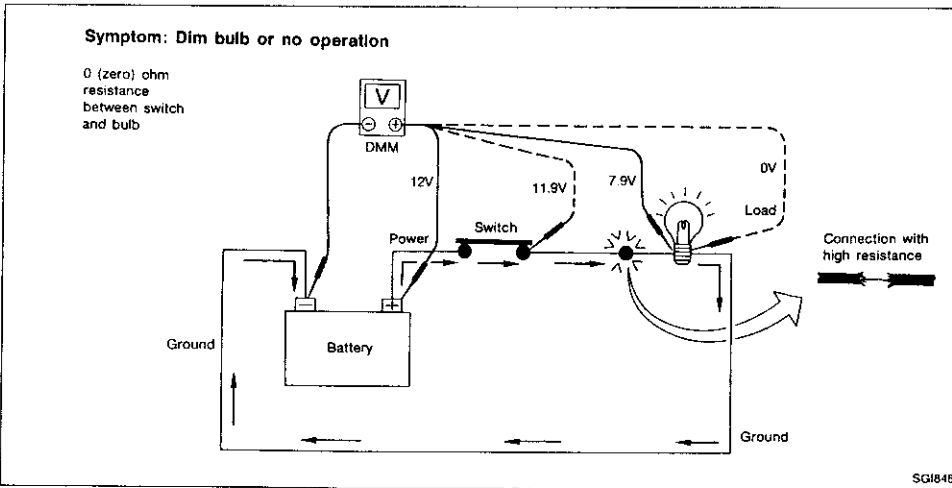

#### Measuring voltage drop — Step by step

The step by step method is most useful for isolating excessive drops in low voltage systems (such as those in "Computer Controlled Systems").

Circuits in the "Computer Controlled System" operate on very low amperage.

The (Computer Controlled) system operations can be adversely affected by any variation in resistance in the system. Such resistance variation may be caused by poor connection, improper installation, improper wire gauge or corrosion.

The step by step voltage drop test can identify a component or wire with too much resistance.

## HOW TO PERFORM EFFICIENT DIAGNOSIS FOR AN ELECTRICAL INCIDENT

### Circuit Inspection (Cont'd)

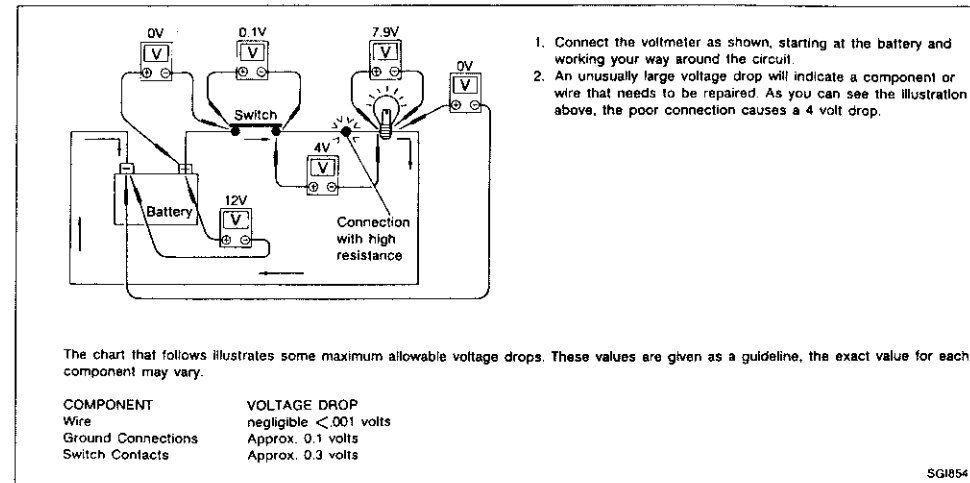

# HOW TO PERFORM EFFICIENT DIAGNOSIS FOR AN ELECTRICAL INCIDENT

## Circuit Inspection (Cont'd)

### Relationship between open/short (high resistance) circuit and the ECU pin control

System Description: When the switch is ON, the ECU lights up the lamp.

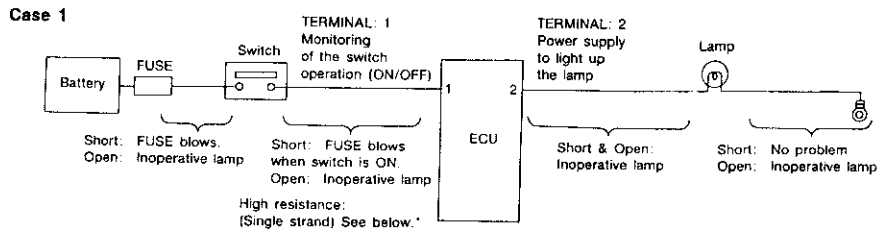

#### Input-output voltage chart

Pin No.	Item	Condition	Voltage value [V]	In case of high resistance such as single strand [V] *
1	Switch	Switch ON	Battery voltage	Lower than battery voltage Approx. 8 (Example)
		Switch OFF	Approx. 0	Approx. 0
2	Lamp	Switch ON	Battery voltage (inoperative lamp)	Approx. 0
		Switch OFF	Approx. 0	Approx. 0

The voltage value is based on the body ground.

\* If high resistance exists in the switch side circuit (caused by a single strand), terminal 1 does not detect battery voltage. ECM does not detect the switch is ON even if the switch does turn ON. Therefore, the ECM does not supply power to light up the lamp.

#### Case 2

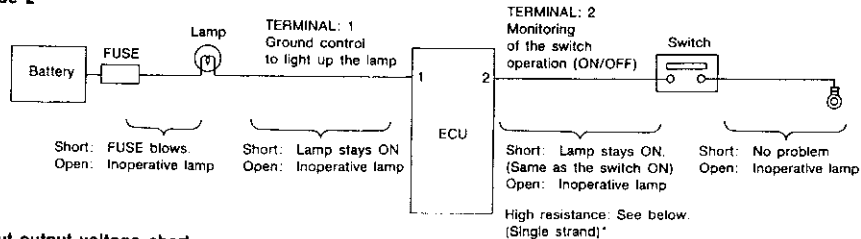

#### Input-output voltage chart

Pin No.	Item	Condition	Voltage value [V]	In case of high resistance such as single strand [V] *
1	Lamp	Switch ON	Approx. 0	Battery voltage (Inoperative lamp)
		Switch OFF	Battery voltage	Battery voltage
2	Switch	Switch ON	Approx. 0	Higher than 0 Approx. 4 (Example)
		Switch OFF	Approx. 5	Approx. 5

The voltage value is based on the body ground.

\* If high resistance exists in the switch side circuit (caused by a single strand), terminal 2 does not detect approx. 0V. ECM does not detect the switch is ON even if the switch does turn ON. Therefore, the ECM does not control ground to light up the lamp.

SG1849

# HOW TO FOLLOW FLOW CHART IN TROUBLE DIAGNOSES

## NOTICE

The flow chart indicates work procedures required to diagnose problems effectively. Observe the following instructions before diagnosing.

- 1) Use the flow chart after locating probable causes of a problem following the "Preliminary Check" or the "Symptom Chart".
- 2) After repairs, re-check that the problem has been completely eliminated.
- 3) Refer to Component Parts and Harness Connector Location for the Systems described in each section for identification/location of components and harness connectors.
- 4) Refer to the Circuit Diagram for Quick Pinpoint Check. If you must check circuit continuity between harness connectors in more detail, such as when a sub-harness is used, refer to Wiring Diagram in each individual section and Harness Layout in EL section for identification of harness connectors.
- 5) When checking circuit continuity, ignition switch should be "OFF".
- 6) Before checking voltage at connectors, check battery voltage.
- 7) After accomplishing the Diagnostic Procedures and Electrical Components Inspection, make sure that all harness connectors are reconnected as they were.

## Example

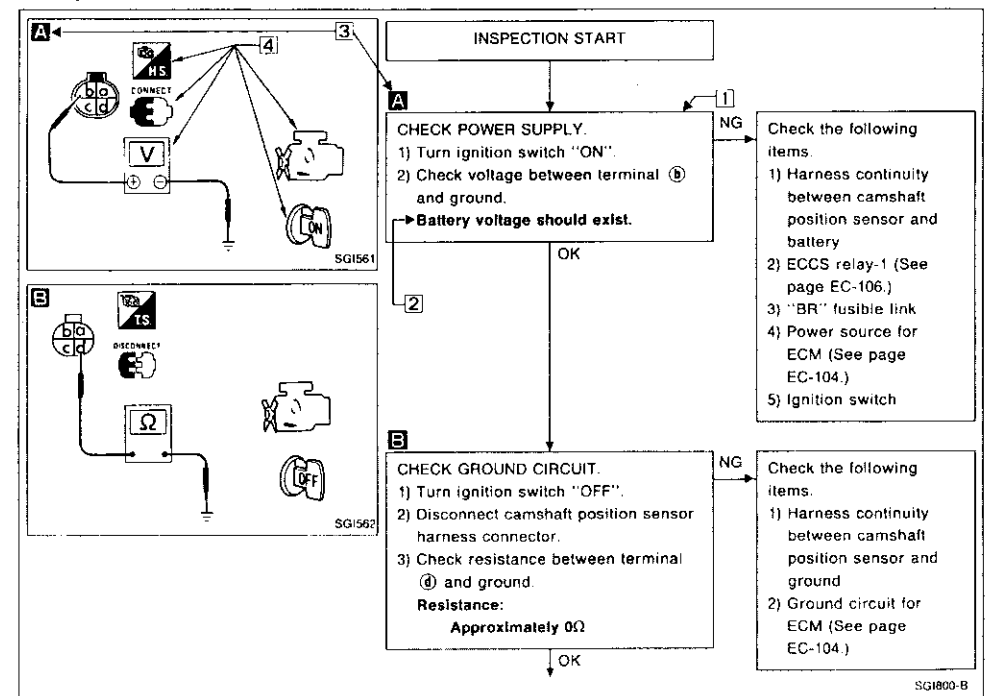

SG1800-B

[REDACTED]

GI

MA

EM

LC

EC

FE

CL

MT

AT

PO

FA

RA

SP

ST

RS

BT

HA

FI

IC

[REDACTED]



## CONSULT CHECKING SYSTEM

### Function and System Application

Diagnostic test mode	Function	ECCS	A/T	AIR BAG*
Work support	This mode enables a technician to adjust some devices faster and more accurately by following the indications on CONSULT.	X	—	—
Self-diagnostic results	Self-diagnostic results can be read and erased quickly.	X	X	X
Data monitor	Input/Output data in the ECM can be read.	X	X	—
Active test	Diagnostic Test Mode in which CONSULT drives some actuators apart from the ECMs and also shifts some parameters in a specified range.	X	—	—
ECM part number	ECM part number can be read.	X	X	—
Function test	Conducted by CONSULT instead of a technician to determine whether each system is "OK" or "NG".	X	—	—

X: Applicable

\* The existing program card (EE922) is applicable only to driver's side air bag system on vehicles outside Europe.

### Lithium Battery Replacement

CONSULT contains a lithium battery. When replacing the battery obey the following:

#### WARNING:

Replace the lithium battery with SANYO Electric Co., Ltd., CR2032 only. Use of another battery may present a risk of fire or explosion. The battery may present a fire or chemical burn hazard if mistreated. Do not recharge, disassemble or dispose of in fire.

Keep the battery out of reach of children and discard used battery conforming to the local regulations.

### Checking Equipment

When ordering the below equipment, contact your NISSAN distributor.

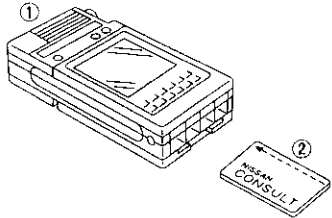
Tool name	Description
<b>NISSAN CONSULT</b> ① CONSULT unit and accessories ② Program card (EE 922) (AE930)*	 <p>NT004</p>

\* For Australia

## IDENTIFICATION INFORMATION

### Model Variation

Body type	Engine	Destination	Axle	Transmission	Applied model	
					Right-hand drive	Left-hand drive
Coupe	SR20DET	Europe	2WD	5-speed M/T	GBYARRF-UE4	GBYALRF-UG4
				4-speed A/T	GBYARRA-UE4	GBYALRA-UG4
		Australia Except Europe and Australia		5-speed M/T	GBYARRA-UM4	—
				4-speed A/T	GBYARRA-UM4	—
				5-speed M/T	GBYARTF-UH4	GBYALRF-UG4
4-speed A/T	GBYARTA-UH4	GBYALRA-UG4				

### Prefix and suffix designations:

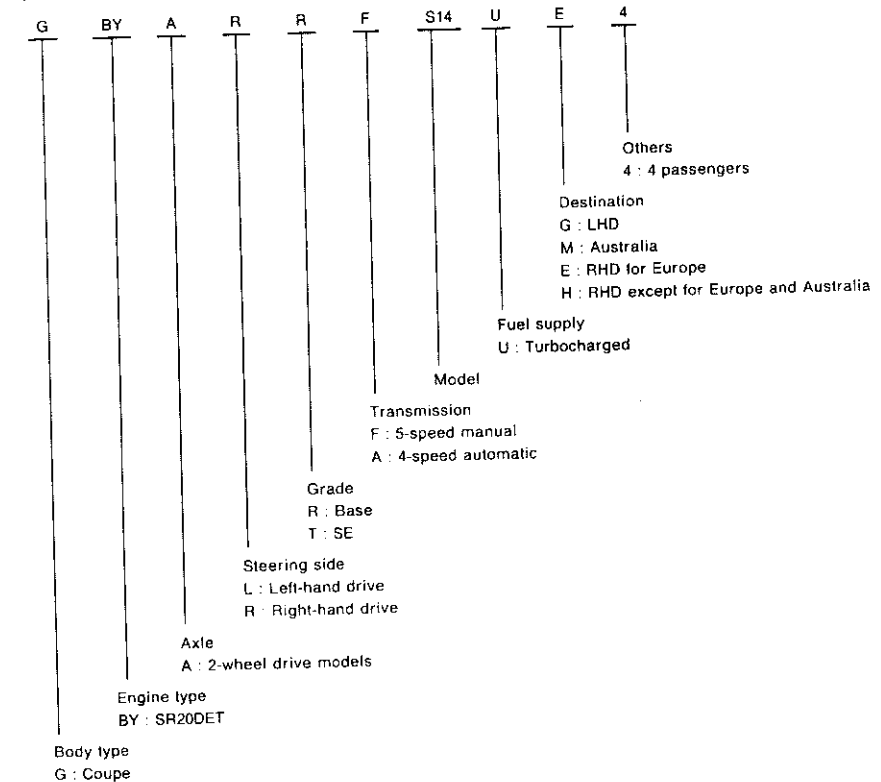

# IDENTIFICATION INFORMATION

## Identification Number

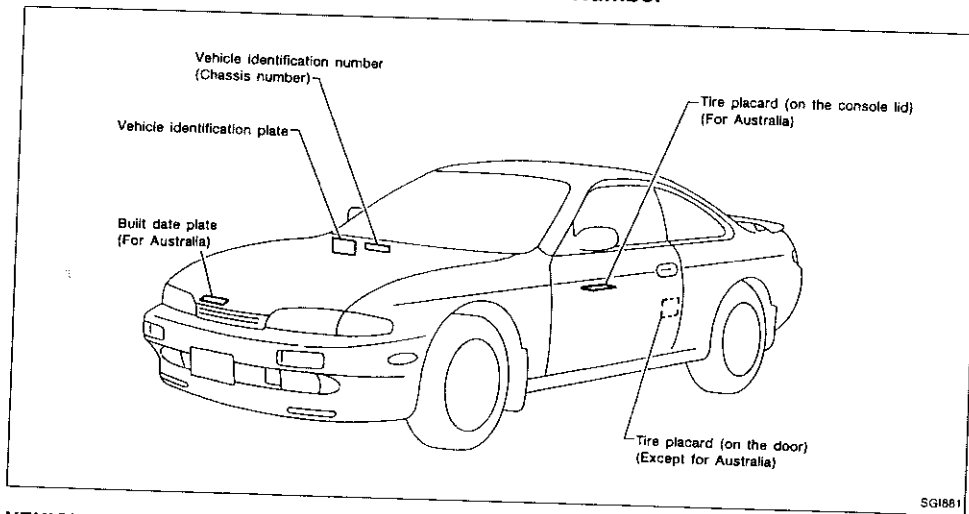

## VEHICLE IDENTIFICATION NUMBER ARRANGEMENT

### For Europe

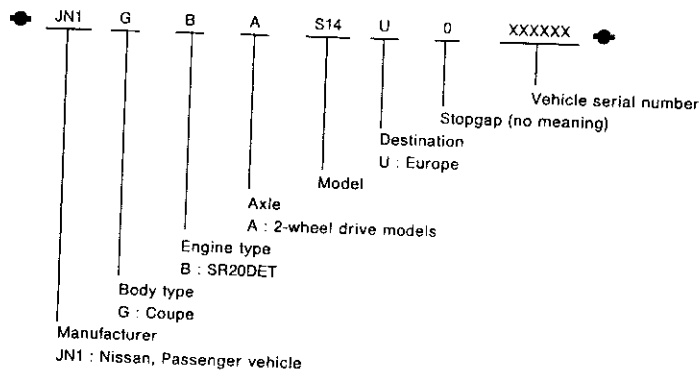

# IDENTIFICATION INFORMATION

## Identification Number (Cont'd)

### For Australia and New Zealand

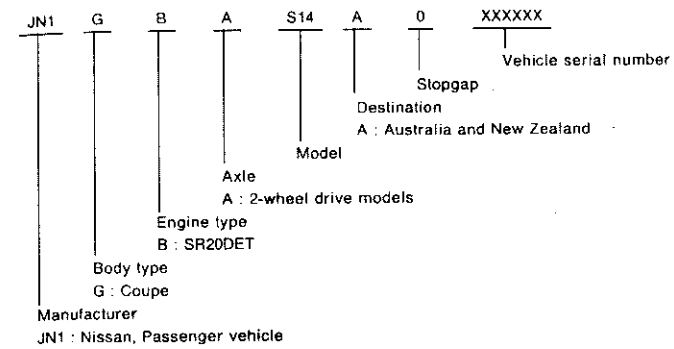

### Except Europe, Australia and New Zealand

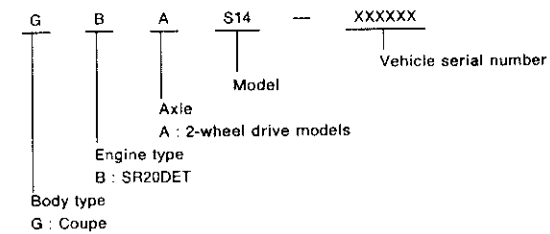

GI  
MA  
EM  
LC  
EC  
FE  
CL  
MT  
AT  
PD  
FA  
RA  
BR  
ST  
RS  
BT  
HA  
EL  
IDX

## IDENTIFICATION INFORMATION

### Identification Number (Cont'd)

#### IDENTIFICATION PLATE

NISSAN MOTOR CO., LTD. JAPAN		型式	TYPE	△
CHASSIS NO. NO. DE CHASSIS		△	△	△
MODEL		△	△	△
COLOR TRIM カラーカラー		△	△	△
ENGINE エンジン		△	△	△
TRANS AXLE トランスアクセル		△	△	△
PLANT 工場		△	△	△
MADE IN JAPAN				

1 Type  
2 Vehicle identification number (Chassis number)  
3 Model  
4 Body color code  
5 Trim color code  
6 Engine model  
7 Engine displacement  
8 Transmission model  
9 Axle model

日産自動車株式会社

SGI315

#### ENGINE SERIAL NUMBER

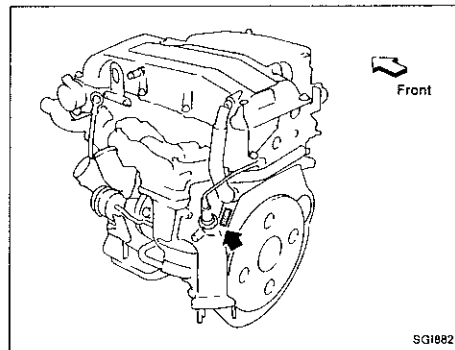

#### MANUAL TRANSMISSION NUMBER

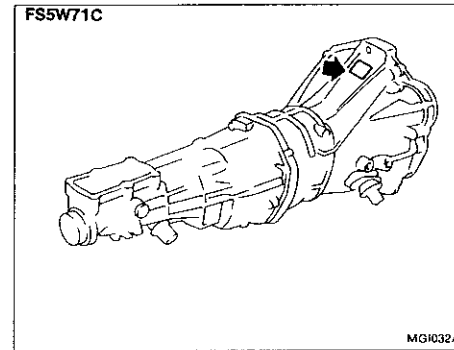

#### AUTOMATIC TRANSMISSION NUMBER

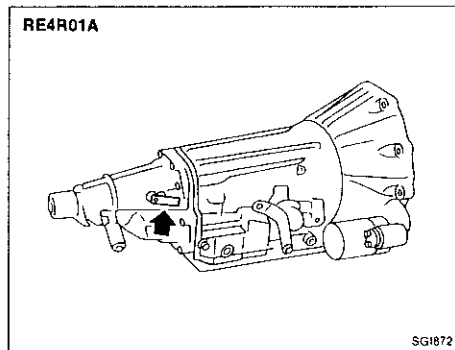

## IDENTIFICATION INFORMATION

#### Dimensions

Overall length	mm (in)	4,520 (178.0)
Overall width	mm (in)	1,730 (68.1)
Overall height	mm (in)	1,295 (51.0)
Front tread	mm (in)	1,480 (58.3)
Rear tread	mm (in)	1,470 (57.9)
Wheelbase	mm (in)	2,525 (99.4)

#### Wheels and Tires

Road wheel		
Steel*1		16 x 6-1/2JJ 16 x 4T*2
Aluminum		16 x 6-1/2JJ
Offset	mm (in)	40 (1.57), 30 (1.18)*2
Tire size (Conventional)		205/55R16 89V
Spare tire (T-type)*2		T125/90D16

\*1. For Spare tire

\*2. For Spare tire (T-type) for Australia

GI  
WA  
EM  
LC  
EC  
FE  
CL  
MT  
AT  
OD  
FA  
BA  
BR  
ST  
RS  
BT  
GA  
FL  
DX

## LIFTING POINTS AND TOW TRUCK TOWING

### 2-pole Lift

#### WARNING:

When lifting the vehicle, open the lift arms as wide as possible and ensure that the front and rear of the vehicle are well balanced.

When setting the lift arm, do not allow the arm to contact the brake tubes and fuel lines.

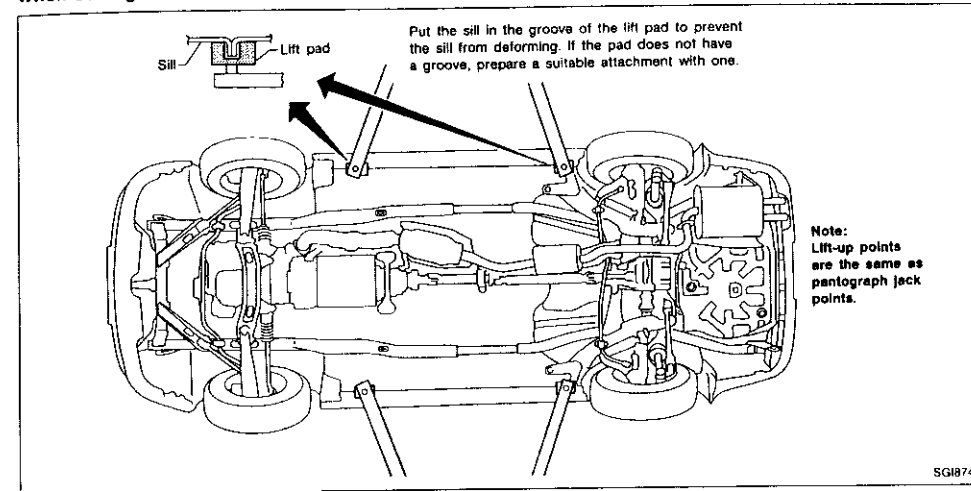

### Preparation

#### SPECIAL SERVICE TOOLS

Tool number (Kent-Moore No.) Tool name	Description
LM4086-0200 ( — ) Board-on lift attachment	 NT001
LM4519-0000 ( — ) Safety stand attachment	 NT002

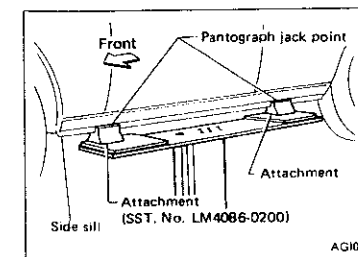

### Board-on Lift

#### CAUTION:

Make sure vehicle is empty when lifting.

- The board-on lift attachment (LM4086-0200) set at front end of vehicle should be set on the front of the sill under the front door opening.
- Position attachments at front and rear ends of board-on lift.

GI

MA

EM

LC

EC

FE

CL

MT

AT

PD

FA

RA

BR

ST

PS

BT

HA

EL

FD

to sup  
ocks a  
g bod,

SG1873

## LIFTING POINTS AND TOW TRUCK TOWING

### Tow Truck Towing

#### CAUTION:

- All applicable local laws regarding the towing operation must be obeyed.
- It is necessary to use proper towing equipment to avoid possible damage to the vehicle during towing operation. Towing is in accordance with Towing Procedure Manual at dealer.
- When towing with the rear wheels on the ground, release the parking brake and move the gearshift lever to neutral position ("N" position).

NISSAN recommends that vehicle be towed with the driving (rear) wheels off the ground as illustrated.

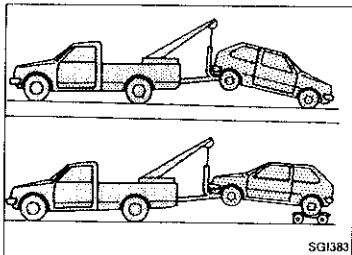

### TOWING AN AUTOMATIC TRANSMISSION MODEL WITH FOUR WHEELS ON GROUND OR TOWING WITH FRONT WHEELS RAISED (With rear wheels on ground)

Observe the following restricted towing speeds and distances.

#### Speed:

Below 50 km/h (30 MPH)

#### Distance:

Less than 65 km (40 miles)

If the speed or distance must necessarily be greater, remove the propeller shaft beforehand to prevent damage to the transmission.

### TOWING POINT

Always pull the cable straight out from the vehicle. Never pull on the hook at a sideways angle.

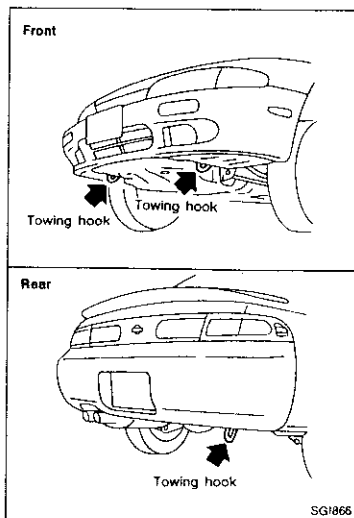

## TIGHTENING TORQUE OF STANDARD BOLTS

Grade	Bolt size	Bolt diameter* mm	Pitch mm	Tightening torque (Without lubricant)					
				Hexagon head bolt			Hexagon flange bolt		
				N·m	kg·m	ft·lb	N·m	kg·m	ft·lb
4T	M6	6.0	1.0	5.1	0.52	3.8	6.1	0.62	4.5
	M8	8.0	1.25	13	1.3	9	15	1.5	11
			1.0	13	1.3	9	16	1.6	12
	M10	10.0	1.5	25	2.5	18	29	3.0	22
			1.25	25	2.6	19	30	3.1	22
			1.75	42	4.3	31	51	5.2	38
M12	12.0	1.25	46	4.7	34	56	5.7	41	
M14	14.0	1.5	74	7.5	54	88	9.0	65	
7T	M6	6.0	1.0	8.4	0.86	6.2	10	1.0	7
	M8	8.0	1.25	21	2.1	15	25	2.5	18
			1.0	22	2.2	16	26	2.7	20
	M10	10.0	1.5	41	4.2	30	48	4.9	35
			1.25	43	4.4	32	51	5.2	38
	M12	12.0	1.75	71	7.2	52	84	8.6	62
1.25			77	7.9	57	92	9.4	68	
M14	14.0	1.5	127	13.0	94	147	15.0	108	
9T	M6	6.0	1.0	12	1.2	9	15	1.5	11
	M8	8.0	1.25	29	3.0	22	35	3.6	26
			1.0	31	3.2	23	37	3.8	27
	M10	10.0	1.5	59	6.0	43	70	7.1	51
			1.25	62	6.3	46	74	7.5	54
	M12	12.0	1.75	98	10.0	72	118	12.0	87
1.25			108	11.0	80	137	14.0	101	
M14	14.0	1.5	177	18.0	130	206	21.0	152	

1. Special parts are excluded.

2. This standard is applicable to bolts having the following marks embossed on the bolt head.

\*: Nominal diameter

Grade	Mark
4T	4
7T	7
9T	9

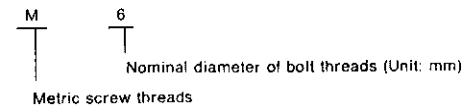

SAE J1930 TERMINOLOGY LIST

SAE J1930 Terminology List

All emission related terms used in this publication in accordance with SAE J1930 are listed. Accordingly, new terms, new acronyms/abbreviations and old terms are listed in the following chart.

\*\*\*: Not applicable

NEW TERM	NEW ACRONYM / ABBREVIATION	OLD TERM
Air cleaner	ACL	Air cleaner
Barometric pressure	BARO	***
Barometric pressure sensor-BCDD	BAROS-BCDD	BCDD
Camshaft position	CMP	***
Camshaft position sensor	CMPS	Crank angle sensor
Carburetor	CARB	Carburetor
Charge air cooler	CAC	Intercooler
Closed loop	CL	Closed loop
Closed throttle position switch	CTP switch	Idle switch
Clutch pedal position switch	CPP switch	Clutch switch
Continuous fuel injection system	CFI system	***
Continuous trap oxidizer system	CTOX system	***
Crankshaft position	CKP	***
Crankshaft position sensor	CKPS	***
Data link connector	DLC	***
Data link connector for CONSULT	DLC for CONSULT	Diagnostic connector for CONSULT
Diagnostic test mode	DTM	Diagnostic mode
Diagnostic test mode selector	DTM selector	Diagnostic mode selector
Diagnostic test mode I	DTM I	Mode I
Diagnostic test mode II	DTM II	Mode II
Diagnostic trouble code	DTC	Malfunction code
Direct fuel injection system	DFI system	***
Distributor ignition system	DI system	Ignition timing control
Early fuel evaporation-mixture heater	EFE-mixture heater	Mixture heater
Early fuel evaporation system	EFE system	Mixture heater control
Electrically erasable programmable read only memory	EEPROM	***
Electronic ignition system	EI system	Ignition timing control
Engine control module	ECM	ECCS control unit
Engine coolant temperature	ECT	Engine temperature
Engine coolant temperature sensor	ECTS	Engine temperature sensor
Engine modification	EM	***
Engine speed	RPM	Engine speed
Erasable programmable read only memory	EPROM	***
Evaporative emission system	EVAP system	Evaporative emission control system
Exhaust gas recirculation valve	EGR valve	EGR valve

SAE J1930 TERMINOLOGY LIST

SAE J1930 Terminology List (Cont'd)

\*\*\*: Not applicable

NEW TERM	NEW ACRONYM / ABBREVIATION	OLD TERM
Exhaust gas recirculation control-BPT valve	EGRC-BPT valve	BPT valve
Exhaust gas recirculation control-solenoid valve	EGRC-solenoid valve	EGR control solenoid valve
Exhaust gas recirculation temperature sensor	EGR temperature sensor	Exhaust gas temperature sensor
Flash electrically erasable programmable read only memory	FEEPROM	***
Flash erasable programmable read only memory	FEPRM	***
Flexible fuel sensor	FFS	***
Flexible fuel system	FF system	***
Heated Oxygen sensor	HO2S	Exhaust gas sensor
Idle air control system	IAC system	Idle speed control
Idle air control valve-air regulator	IACV-air regulator	Air regulator
Idle air control valve-auxiliary air control valve	IACV-AAC valve	Auxiliary air control (AAC) valve
Idle air control valve-FICD solenoid valve	IACV-FICD solenoid valve	FICD solenoid valve
Idle air control valve-idle up control solenoid valve	IACV-idle up control solenoid valve	Idle up control solenoid valve
Idle speed control-Fi pot	ISC-Fi pot	Fi pot
Idle speed control system	ISC system	***
Ignition control module	ICM	***
Indirect fuel injection system	IFI system	***
Intake air temperature sensor	IATS	Air temperature sensor
Knock	***	Detonation
Knock sensor	KS	Detonation sensor
Malfunction indicator lamp	MIL	Check engine light
Manifold absolute pressure	MAP	***
Manifold absolute pressure sensor	MAPS	***
Manifold differential pressure	MDP	***
Manifold differential pressure sensor	MDPS	***
Manifold surface temperature	MST	***
Manifold surface temperature sensor	MSTS	***
Manifold vacuum zone	MVZ	***
Manifold vacuum zone sensor	MVZS	***
Mass air flow sensor	MAFS	Air flow meter
Mixture control solenoid valve	MC solenoid valve	Air-fuel ratio control solenoid valve
Multiport fuel injection System	MFI system	Fuel injection control
Neutral position switch	***	Neutral switch
Non-volatile random access memory	NVRAM	***
On-board diagnostic system	OBD system	Self-diagnosis
Open loop	OL	Open loop
Oxidation catalyst	OC	Catalyst

SAE J1930 TERMINOLOGY LIST

SAE J1930 Terminology List (Cont'd)

\*\*\*: Not applicable

NEW TERM	NEW ACRONYM / ABBREVIATION	OLD TERM
Oxidation catalytic converter system	OC system	***
Oxygen sensor	O2S	Exhaust gas sensor
Park position switch	***	Park switch
Park/neutral position switch	PNP switch	Park/neutral switch
Periodic trap oxidizer system	PTOX system	***
Powertrain control module	PCM	***
Programmable read only memory	PROM	***
Pulsed secondary air injection control solenoid valve	PAIRC solenoid valve	AIV control solenoid valve
Pulsed secondary air injection system	PAIR system	Air induction valve(AIV) control
Pulsed secondary air injection valve	PAIR valve	Air induction valve
Random access memory	RAM	***
Read only memory	ROM	***
Scan tool	ST	***
Secondary air injection pump	AIR pump	***
Secondary air injection system	AIR system	***
Sequential multipoint fuel injection system	SFI system	Sequential fuel injection
Service reminder indicator	SRI	***
Simultaneous multipoint fuel injection system	***	Simultaneous fuel injection
Smoke puff limiter system	SPL system	***
Supercharger	SC	***
Supercharger bypass	SCB	***
System readiness test	SRT	***
Thermal vacuum valve	TVV	Thermal vacuum valve
Three way catalyst	TWC	Catalyst
Three way catalytic converter system	TWC system	***
Three way + oxidation catalyst	TWC + OC	Catalyst
Three way + oxidation catalytic converter system	TWC + OC system	***
Throttle body	TB	Throttle chamber SPI body
Throttle body fuel injection system	TBI system	Fuel injection control
Throttle position	TP	Throttle position
Throttle position sensor	TPS	Throttle sensor
Throttle position switch	TP switch	Throttle switch
Torque converter clutch solenoid valve	TCC solenoid valve	Lock-up cancel solenoid Lock-up solenoid
Turbocharger	TC	Turbocharger
Vehicle speed sensor	VSS	Vehicle speed sensor
Volume air flow sensor	VAFS	Air flow meter

SAE J1930 TERMINOLOGY LIST

SAE J1930 Terminology List (Cont'd)

\*\*\*: Not applicable

NEW TERM	NEW ACRONYM / ABBREVIATION	OLD TERM
Warm up oxidation catalyst	WU-OC	Catalyst
Warm up oxidation catalytic converter system	WU-OC system	***
Warm up three-way catalyst	WU-TWC	Catalyst
Warm up three-way catalytic converter system	WU-TWC system	***
Wide open throttle position switch	WOTP switch	Full switch

GI  
MA  
EM  
LC  
EC  
FE  
CL  
MT  
AT  
PD  
FA  
RA  
BR  
ST  
RS  
BT  
HA  
EL  
DX

# ENGINE MECHANICAL

## SECTION **EM**

GI  
MA  
EM  
LC  
EC  
FE  
CL  
WT  
AT  
PD  
FA  
RA  
BR  
ST  
RS  
BT  
HA  
EL  
FOX

### CONTENTS

<b>PRECAUTIONS</b> .....	2	Installation.....	36
Supplemental Restraint System (SRS) "AIR BAG" and "SEAT BELT PRE-TENSIONER".....	2	<b>CYLINDER HEAD</b> .....	38
Parts Requiring Angular Tightening.....	2	Removal and Installation.....	39
Liquid Gasket Application Procedure.....	2	Disassembly.....	39
Special Cautions to Ensure the Safe Disposal of Sodium-filled Exhaust Valves.....	3	Inspection.....	40
<b>PREPARATION</b> .....	5	Assembly.....	46
Special Service Tools.....	5	<b>TURBOCHARGER</b> .....	49
Commercial Service Tools.....	8	Removal.....	49
<b>OUTER COMPONENT PARTS</b> .....	9	Disassembly.....	50
<b>COMPRESSION PRESSURE</b> .....	12	Inspection.....	51
Measurement of Compression Pressure.....	12	Assembly.....	53
<b>OIL PAN</b> .....	13	Installation.....	53
Removal.....	13	<b>ENGINE REMOVAL</b> .....	55
Installation.....	16	Removal.....	56
<b>TIMING CHAIN</b> .....	19	Installation.....	56
Removal.....	20	<b>CYLINDER BLOCK</b> .....	57
Inspection.....	23	Disassembly.....	58
Installation.....	24	Inspection.....	59
<b>OIL SEAL REPLACEMENT</b> .....	32	Assembly.....	67
<b>INTAKE MANIFOLD</b> .....	35	<b>SERVICE DATA AND SPECIFICATIONS (SDS)</b> .....	72
Removal.....	35	General Specifications.....	72
		Inspection and Adjustment.....	73



## PRECAUTIONS

### Supplemental Restraint System (SRS) "AIR BAG" and "SEAT BELT PRE-TENSIONER"

The Supplemental Restraint System "Air Bag" and "Seat Belt Pre-tensioner", used along with a seat belt, help to reduce the risk or severity of injury to the driver and front passenger in a frontal collision. The Supplemental Restraint System consists of air bag modules (located in the center of the steering wheel and on the instrument panel on the passenger side), seat belt pre-tensioners, a diagnosis sensor unit, warning lamp, wiring harness and spiral cable. Information necessary to service the system safely is included in the RS section of this Service Manual.

#### WARNING:

- To avoid rendering the SRS inoperative, which could increase the risk of personal injury or death in the event of a collision which would result in air bag inflation, all maintenance must be performed by an authorized NISSAN dealer.
- Improper maintenance, including incorrect removal and installation of the SRS, can lead to personal injury caused by unintentional activation of the system.
- All SRS air bag electrical wiring harnesses and connectors are covered with yellow outer insulation. Do not use electrical test equipment on any circuit related to the SRS.

### Parts Requiring Angular Tightening

Use an angle wrench for the final tightening of the following engine parts:

- Cylinder head bolts
- Main bearing cap bolts
- Connecting rod bearing cap nuts

Do not use a torque value for final tightening.

The torque values for these parts are for a preliminary step. Ensure thread and seat surfaces are clean and coated with engine oil.

### Liquid Gasket Application Procedure

- Use a scraper to remove all traces of old liquid gasket from mating surfaces and grooves. Also, completely clean any oil from these areas.
- Apply a continuous bead of liquid gasket to mating surfaces. (Use Genuine Liquid Gasket or equivalent.)
  - Be sure liquid gasket is 4.0 to 5.0 mm (0.157 to 0.197 in) wide (for oil pan).
  - Be sure liquid gasket is 2.0 to 3.0 mm (0.079 to 0.118 in) wide (in areas except oil pan).
- Apply liquid gasket to inner surface around hole perimeter. (Assembly should be done within 5 minutes after coating.)
- Wait at least 30 minutes before refilling engine oil and engine coolant.

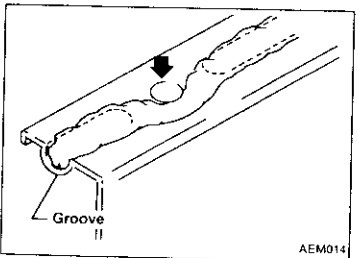
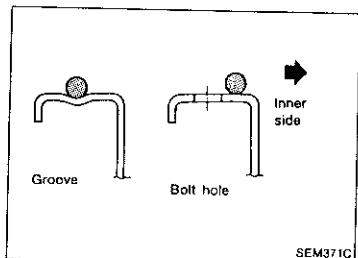

## PRECAUTIONS

### Special Cautions to Ensure the Safe Disposal of Sodium-filled Exhaust Valves

The handling and disposal of sodium-filled exhaust valves requires special care and consideration. Under conditions such as breakage with subsequent exposure to water, the sodium metal will react violently. The sodium metal, which lines the inner portion of the exhaust valve, forms sodium hydroxide. Also, it releases hydrogen gas which may result in an explosion or fire.

A sodium-filled exhaust valve is identified on the top of its stem as shown in illustration.

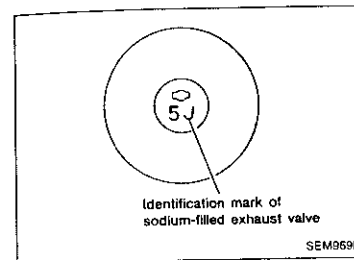

### DEALER DISPOSAL INSTRUCTIONS

#### CAUTION:

- Use approved shatter-resistant eye protection when performing this procedure.
- Perform this and all subsequent disposal work procedures in an open room, away from flammable liquids. Keep a fire extinguisher, rated at least 10 ABC, in close proximity to the work area.
- Be sure to wear rubber gloves when performing the following operations.

- Clamp valve stem in a vice.
- The valve has a specially-hardened surface. To cut through it, first remove a half-round section, approximately 30 mm (1.18 in) long. Use an air-powered grinder until the black iron color is removed and the silver-colored metal appears.
- Use a hacksaw to cut through approximately half the diameter of the valve stem. Make the serration at a point 40 mm (1.57 in) from the end of the stem.

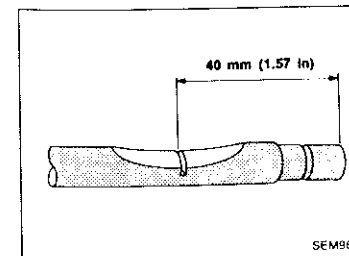
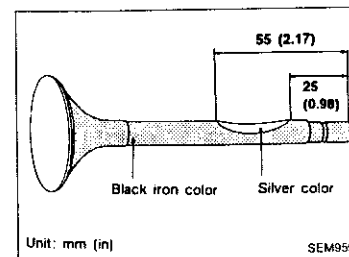

## PRECAUTIONS

### Special Cautions to Ensure the Safe Disposal of Sodium-filled Exhaust Valves (Cont'd)

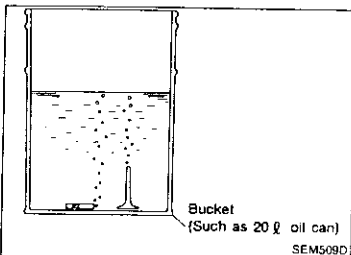
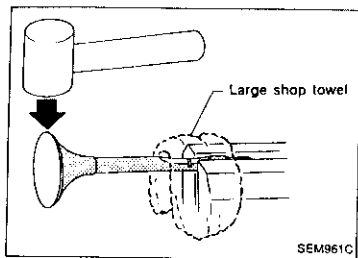

4. Cover the serrated end of the valve with a large shop towel. Strike the valve face end with a hammer, separating it into two pieces.

5. Fill a bucket (such as a 20 l oil can) with at least 10 l (2-1/4 Imp gal) of water. Using a pair of large tweezers, carefully place the already-cut (serrated) valves into the water one at a time. Quickly move away at least 2.7 m (9 ft). Place the valves in a standing valve position as shown in the figure. This allows complete reaction of the sodium with the water. The major portion of the resultant chemical reaction lasts 1 to 2 minutes. After the bubbling action has subsided, additional valves can be placed into the water. Wait until each subsequent chemical reaction subsides before placing additional valves into the water. However, no more than 8 valves should be placed in the same 10 l (2-1/4 Imp gal) amount of water. The complete chemical reaction may take as long as 4 to 5 hours. Remove the valves using a set of large tweezers after the chemical reaction has stopped. Afterwards, the valves can be mixed with ordinary scrap metal.

#### CAUTION:

- Make sure the resultant (high alkalinity) waste water does not contact your skin. If the waste water does contact you, wash the contacted area immediately with large quantities of water.
- Check country and local regulations concerning any chemical treatment or waste water discharge permits. These may be required to dispose of the resultant (high alkalinity) waste water.

## PREPARATION

### Special Service Tools

Tool number Tool name	Description	
ST0501S000 Engine stand assembly ① ST05011000 Engine stand ② ST05012000 Base	Disassembling and assembling	
KV10106500 Engine stand shaft		
KV10115300 Engine sub-attachment		
ST10120000 Cylinder head bolt wrench	Loosening and tightening cylinder head bolt	
KV10116200 Valve spring compressor ① KV10115900 Attachment	Disassembling valve mechanism	
KV101092S0 Valve spring compressor ① KV10109210 Compressor ② KV10109220 Adapter ③ KV10111200 Adapter (Useless)	Disassembling valve mechanism	

**PREPARATION**  
**Special Service Tools (Cont'd)**

\*: Special tool or commercial equivalent

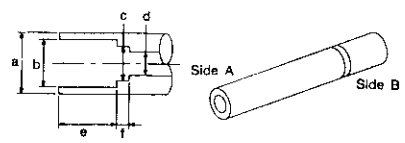
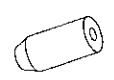
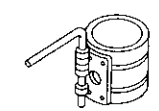
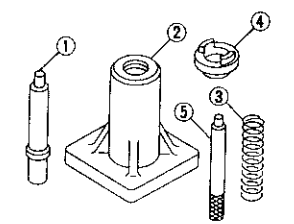
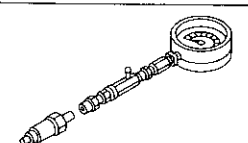
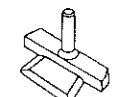
Tool number Tool name	Description																		
KV10115600 Valve oil seal drift	<p align="center">Installing valve oil seal</p> <table border="1"> <thead> <tr> <th>Intake</th> <th>Exhaust</th> </tr> <tr> <th>Side A</th> <th>Side B</th> </tr> </thead> <tbody> <tr> <td><b>Side A</b></td> <td><b>Side B</b></td> </tr> <tr> <td>a: 20 (0.79) dia.</td> <td>a: 20 (0.79) dia.</td> </tr> <tr> <td>b: 13 (0.51) dia.</td> <td>b: 14.2 (0.558) dia.</td> </tr> <tr> <td>c: 10.3 (0.405) dia.</td> <td>c: 11 (0.43) dia.</td> </tr> <tr> <td>d: 8 (0.31) dia.</td> <td>d: 8 (0.31) dia.</td> </tr> <tr> <td>e: 10.7 (0.421)</td> <td>e: 10.7 (0.421) dia.</td> </tr> <tr> <td>f: 5 (0.20)</td> <td>f: 5 (0.20)</td> </tr> </tbody> </table>  <p align="right">Unit: mm (in)</p>	Intake	Exhaust	Side A	Side B	<b>Side A</b>	<b>Side B</b>	a: 20 (0.79) dia.	a: 20 (0.79) dia.	b: 13 (0.51) dia.	b: 14.2 (0.558) dia.	c: 10.3 (0.405) dia.	c: 11 (0.43) dia.	d: 8 (0.31) dia.	d: 8 (0.31) dia.	e: 10.7 (0.421)	e: 10.7 (0.421) dia.	f: 5 (0.20)	f: 5 (0.20)
Intake	Exhaust																		
Side A	Side B																		
<b>Side A</b>	<b>Side B</b>																		
a: 20 (0.79) dia.	a: 20 (0.79) dia.																		
b: 13 (0.51) dia.	b: 14.2 (0.558) dia.																		
c: 10.3 (0.405) dia.	c: 11 (0.43) dia.																		
d: 8 (0.31) dia.	d: 8 (0.31) dia.																		
e: 10.7 (0.421)	e: 10.7 (0.421) dia.																		
f: 5 (0.20)	f: 5 (0.20)																		
KV10115700 Dial gauge stand	<p align="center">Adjusting shims</p> 																		
EM03470000 Piston ring compressor	<p align="center">Installing piston assembly into cylinder bore</p> 																		
KV10107400 Piston pin press stand ① KV10107310 Center shaft ② ST13040020 Stand ③ ST13040030 Spring ④ KV10107320 Cap ⑤ ST13040050 Drift	<p align="center">Disassembling and assembling piston pin</p> 																		
ED19600000* Compression gauge set																			
KV10111100 Seal cutter	<p align="center">Removing oil pan</p> 																		

EM-6

**PREPARATION**  
**Special Service Tools (Cont'd)**

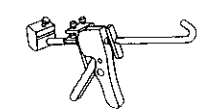
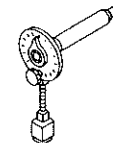
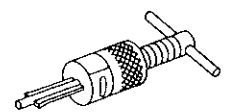
Tool number Tool name	Description	
WS39930000 Tube presser	<p align="center">Pressing the tube of liquid gasket</p> 	GI MA <b>EM</b>
KV10112100 Angle wrench	<p align="center">Tightening bolts for bearing cap, cylinder head, etc.</p> 	LC EC
ST16610001 Pilot bushing puller	<p align="center">Removing pilot bushing</p> 	FE CL MT AT PD FA RA BR SY RS BT HA EI ED

EM-7

# OUTER COMPONENT PARTS

SEC. 111-118-140-147-148-150-163-164  
SEC. 220-223-226

2.9 - 3.8 (0.30 - 0.39, 2.2 - 2.8)

5.1 - 6.5  
(0.52 - 0.66, 3.8 - 4.8)

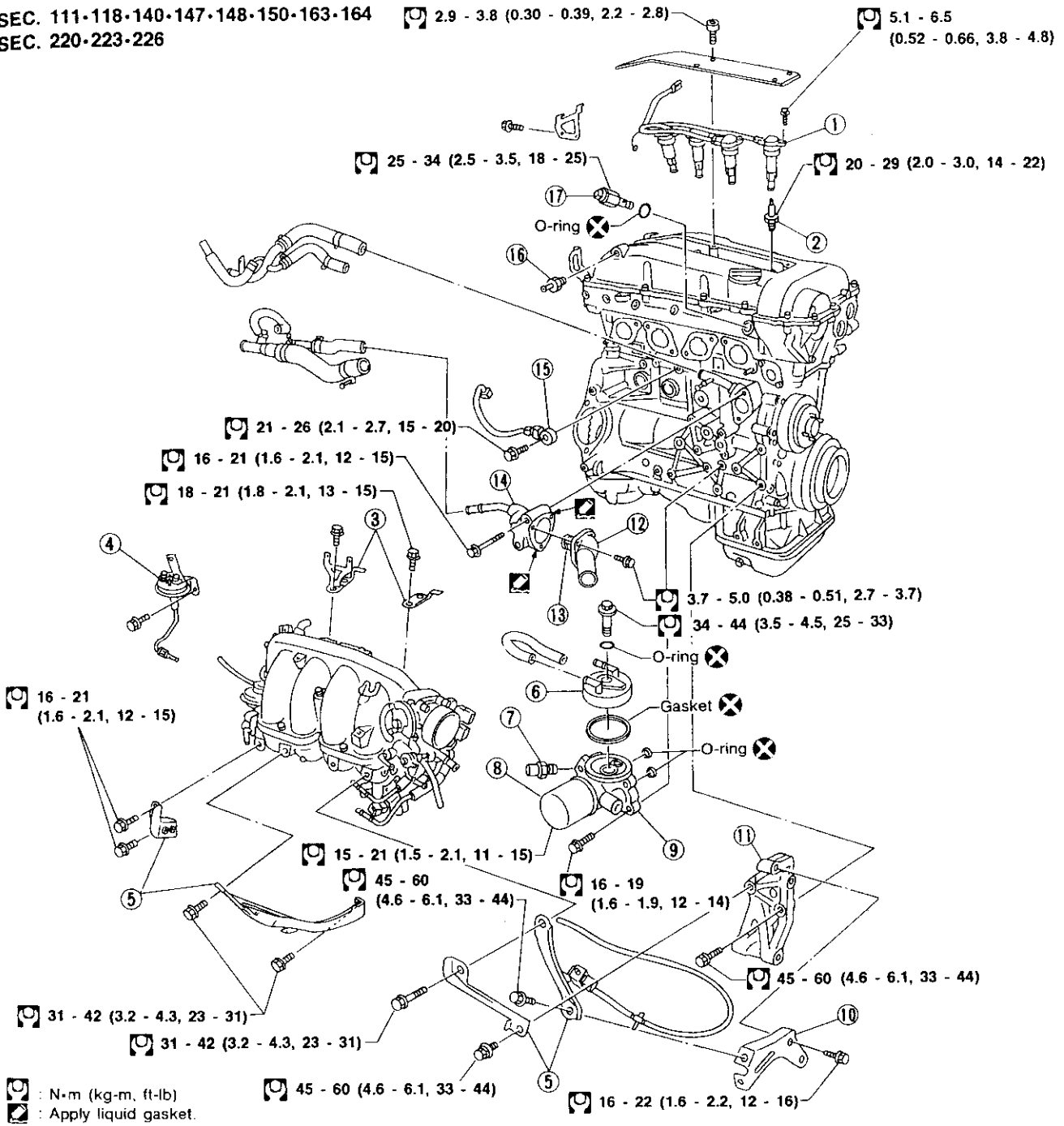

- ① Ignition coil
- ② Spark plug
- ③ Intake manifold collector support
- ④ EGRC-BPT valve
- ⑤ Intake manifold support
- ⑥ Oil cooler



- ⑦ Oil pressure switch
- ⑧ Oil filter
- ⑨ Oil filter bracket
- ⑩ Alternator adjusting bar
- ⑪ Alternator bracket
- ⑫ Water outlet

- ⑬ Thermostat
- ⑭ Thermostat housing
- ⑮ Knock sensor
- ⑯ Blow-by control valve
- ⑰ VTC solenoid valve

GI  
MA  
**EM**  
LG  
EC  
FE  
CL  
MT  
AT  
PD  
FA  
HA  
BR  
ST  
RS  
SEM970E BT  
HA  
EL  
FOX

## PREPARATION

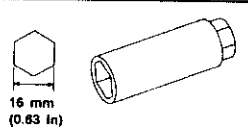
### Commercial Service Tools

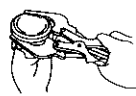
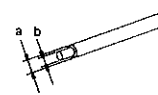
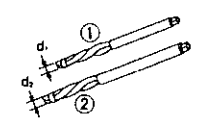
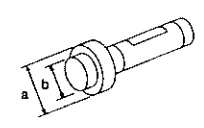
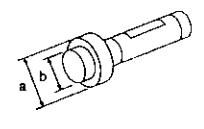
Tool name	Description									
Spark plug wrench	 <p>16 mm (0.63 in)</p> <p>NT047</p> <p>Removing and installing spark plug</p>									
Valve seat cutter set	 <p>NT048</p> <p>Finishing valve seat dimensions</p>									
Piston ring expander	 <p>NT030</p> <p>Removing and installing piston ring</p>									
Valve guide drift	 <p>NT015</p> <p>Removing and installing valve guide</p> <p>Intake a = 9.5 mm (0.374 in) dia. b = 5.0 mm (0.197 in) dia.</p> <p>Exhaust a = 10.5 mm (0.413 in) dia. b = 5.0 mm (0.236 in) dia.</p>									
Valve guide reamer	 <p>NT016</p> <p>Reaming valve guide ① or hole for oversize valve guide ②</p> <p>Unit: mm (in)</p> <table border="1"> <thead> <tr> <th></th> <th>d<sub>1</sub></th> <th>d<sub>2</sub></th> </tr> </thead> <tbody> <tr> <td>Intake</td> <td>6.0 (0.236)</td> <td>10.175 (0.4006)</td> </tr> <tr> <td>Exhaust</td> <td>7.0 (0.276)</td> <td>11.175 (0.4400)</td> </tr> </tbody> </table>		d <sub>1</sub>	d <sub>2</sub>	Intake	6.0 (0.236)	10.175 (0.4006)	Exhaust	7.0 (0.276)	11.175 (0.4400)
	d <sub>1</sub>	d <sub>2</sub>								
Intake	6.0 (0.236)	10.175 (0.4006)								
Exhaust	7.0 (0.276)	11.175 (0.4400)								
Front oil seal drift	 <p>NT049</p> <p>Installing front oil seal</p> <p>a = 75 mm (2.95 in) dia. b = 45 mm (1.77 in) dia.</p>									
Rear oil seal drift	 <p>NT049</p> <p>Installing rear oil seal</p> <p>a = 110 mm (4.33 in) dia. b = 80 mm (3.15 in) dia.</p>									

## OUTER COMPONENT

SEC. 111-118-140-147-148-150-163-164 2.9 - 3.8 (0.30 - 0.39, 2.1  
SEC. 220-223-226

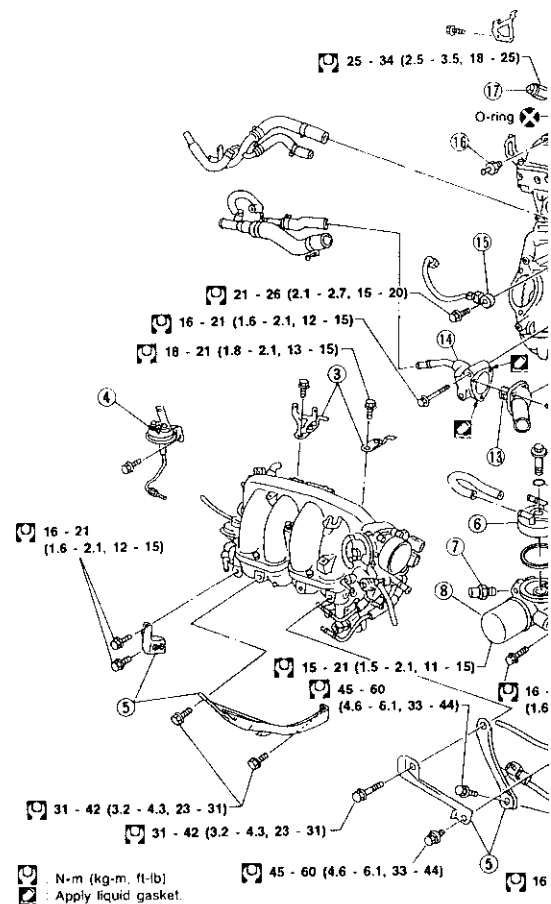

- |                                     |                                |
|-------------------------------------|--------------------------------|
| ① Ignition coil                     | ⑦ Oil pressure switch          |
| ② Spark plug                        | ⑧ Oil filter                   |
| ③ Intake manifold collector support | ⑨ Oil filter bracket           |
| ④ EGRC-BPT valve                    | ⑩ Alternator adjusting bracket |
| ⑤ Intake manifold support           | ⑪ Alternator bracket           |
| ⑥ Oil cooler                        | ⑫ Water outlet                 |

# OUTER COMPONENT PARTS

SEC. 118-140-223

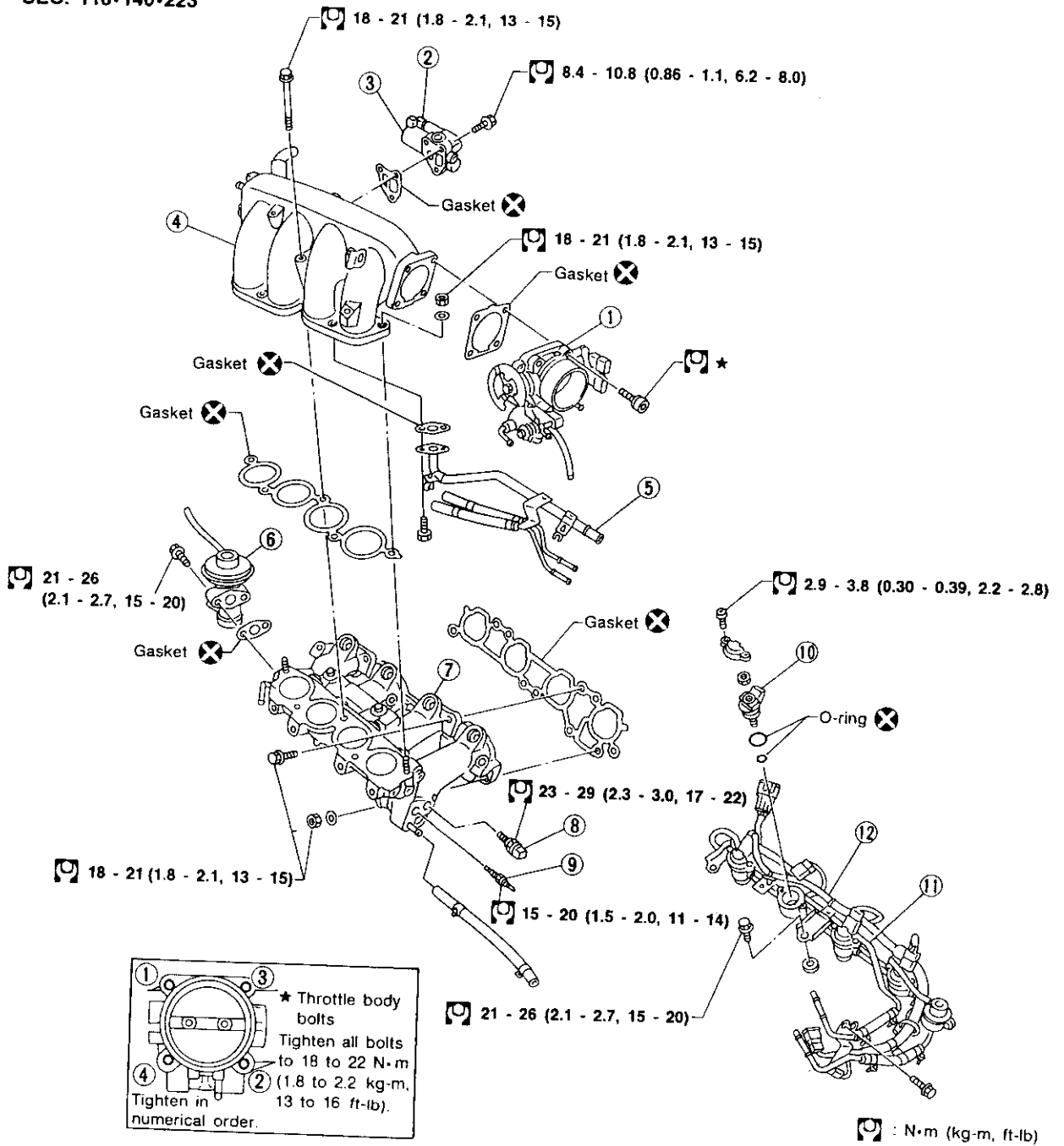

SEM971E

- |                             |                                     |                      |
|-----------------------------|-------------------------------------|----------------------|
| ① Throttle body             | ⑥ EGR valve                         | ⑩ Injector           |
| ② IACV-FICD valve           | ⑦ Intake manifold                   | ⑪ Fuel tube assembly |
| ③ IACV-AAC valve            | ⑧ Engine coolant temperature sensor | ⑫ Injector harness   |
| ④ Intake manifold collector | ⑨ Thermal transmitter               |                      |
| ⑤ Air pipe                  |                                     |                      |

# OUTER COMPONENT PARTS

SEC. 140-144-226

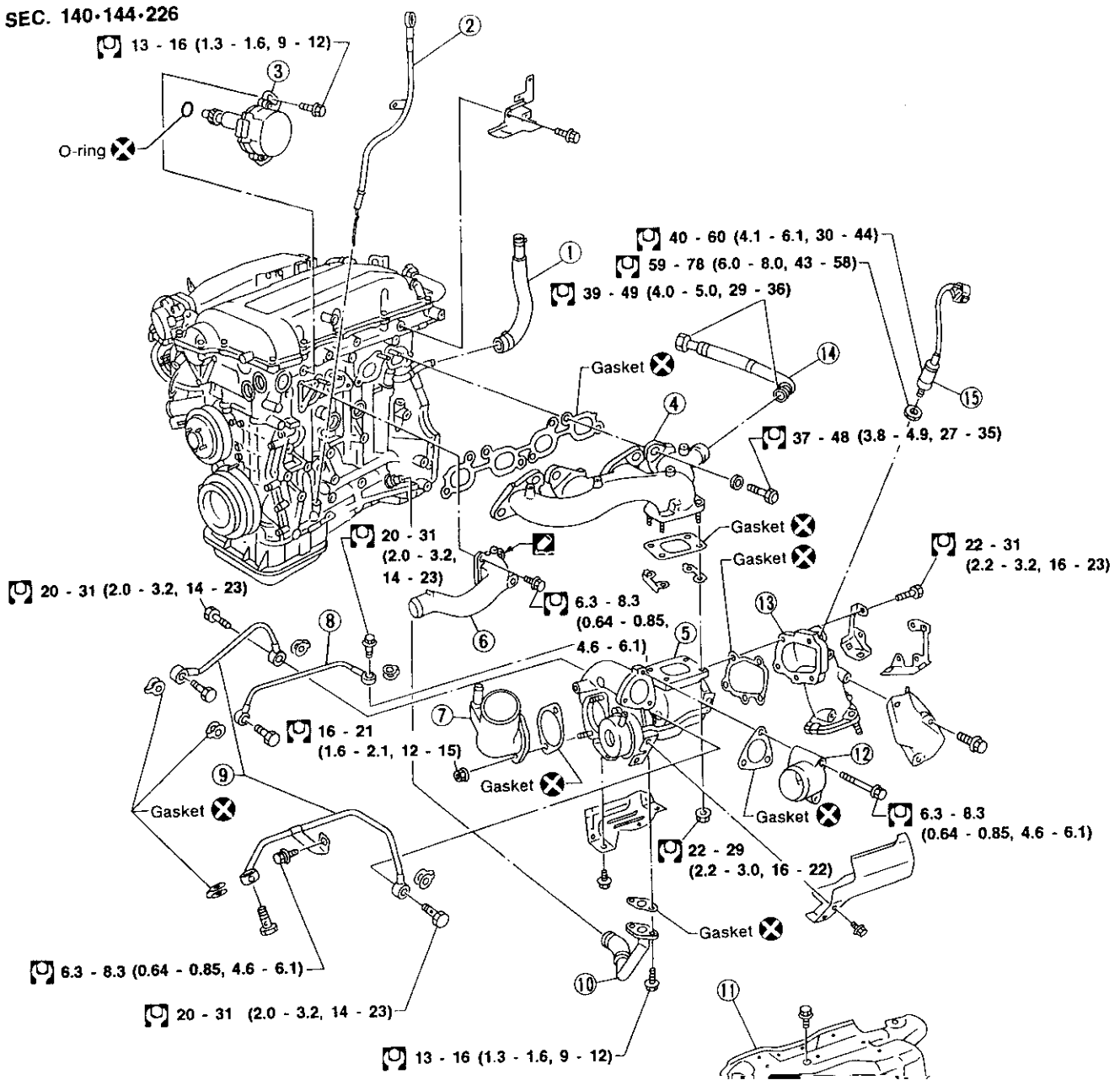

GI

MA

EM

LC

EC

FE

CL

MT

AT

PD

FA

RA

BR

ST

## COMPRESSION PRESSURE

### Measurement of Compression Pressure

1. Warm up engine.
2. Turn ignition switch off.
3. Release fuel pressure.  
Refer to "Releasing Fuel Pressure" in EC section.
4. Remove all spark plugs.
5. Disconnect distributor center cable.

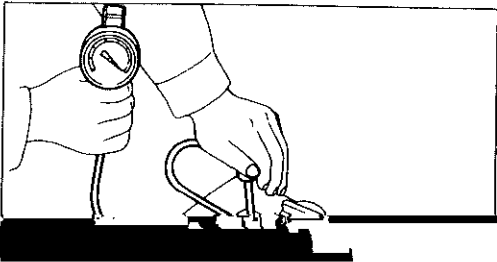

6. Attach a compression tester to No. 1 cylinder.
7. Depress accelerator pedal fully to keep throttle valve wide open.
8. Crank engine and record highest gauge indication.
9. Repeat the measurement on each cylinder as shown above.

**Always use a fully-charged battery to obtain accurate results.**



# OIL PAN

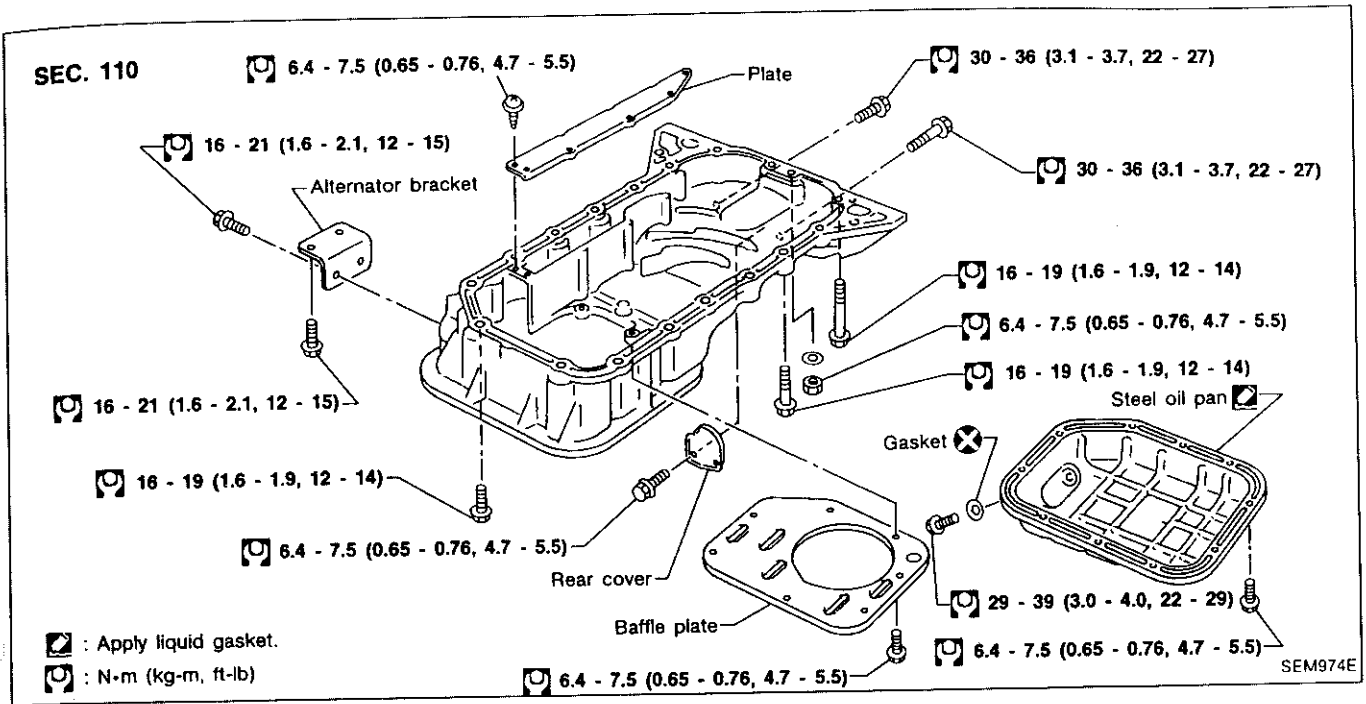

## Removal

1. Remove engine under cover.
2. Drain engine oil.

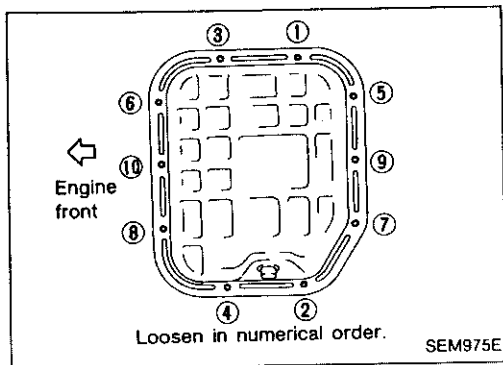

3. Remove steel oil pan bolts.

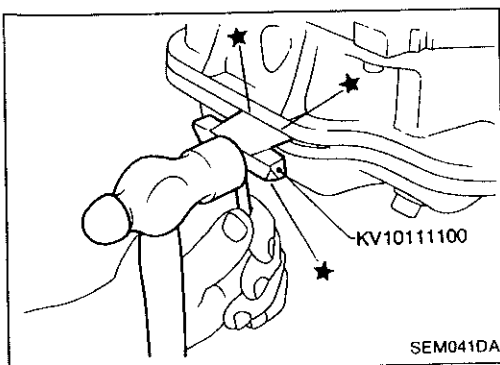

4. Remove steel oil pan.

- (1) Insert Tool between aluminum oil pan and steel oil pan.
  - Be careful not to damage aluminum mating surface.
  - Do not insert screwdriver, or oil pan flange will be deformed.

CI

MA

EM

LC

EC

FE

CL

MT

AT

PD

FA

RA

BR

ST

RS

BT

HA

EL

IDX

## OIL PAN

### Removal (Cont'd)

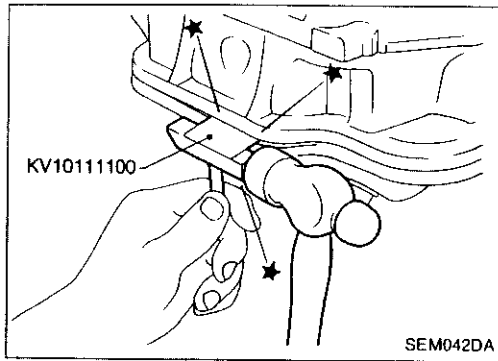

- (2) Slide Tool by tapping on the side of the Tool with a hammer.

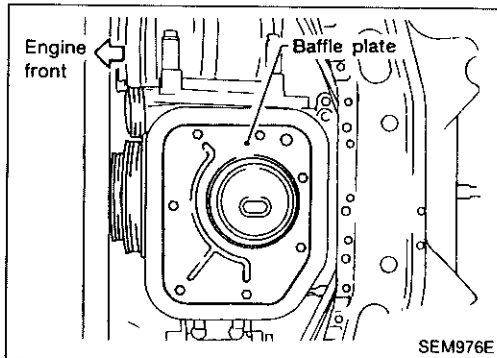

- (3) Remove steel oil pan.  
(4) Remove baffle plate.

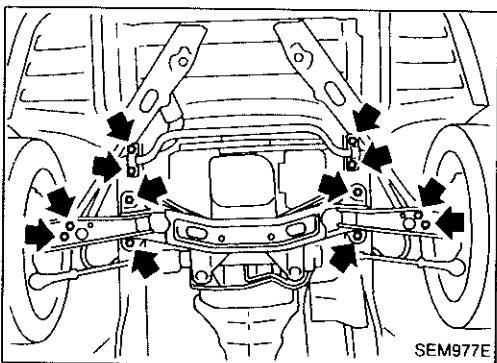

5. Install engine slingers to cylinder head. Refer to "ENGINE REMOVAL" (EM-55).  
6. Set a suitable hoist on engine slinger and hold the engine.  
7. Remove the following parts.
- Tension rod bolts at transverse links
  - Front stabilizer bar securing bolts and nuts from side member.
  - Both left and right side engine mounting bolts. Refer to "ENGINE REMOVAL" (EM-55).
8. Disconnect steering shaft lower joint.

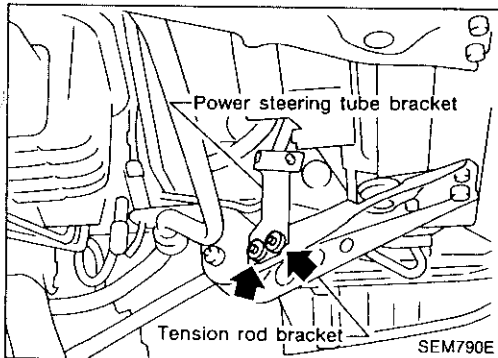

9. Remove power steering tube bracket securing bolts at left tension rod bracket.  
10. Remove front suspension member securing bolts while supporting with a jack.  
11. Lower front suspension member by around 60 mm (2.36 in).

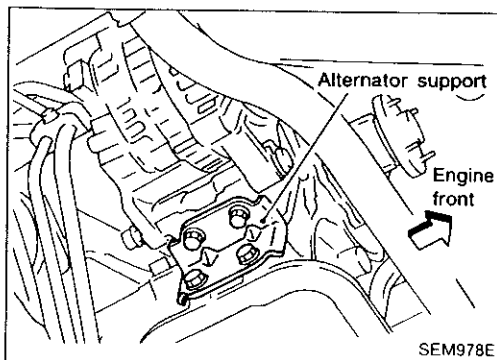

12. Remove alternator support.

## OIL PAN

### Removal (Cont'd)

13. Remove rear cover plate.

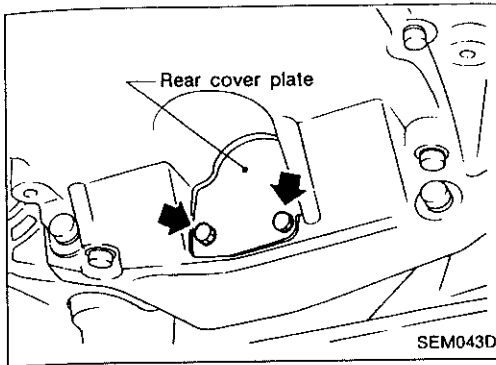

14. Remove aluminum oil pan bolts.

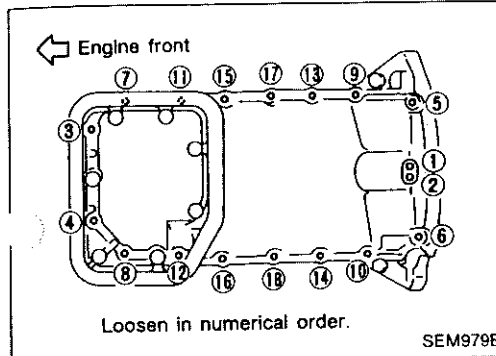

15. Remove four oil pan-to-transmission bolts.

16. Remove two engine-to-transmission bolts and install them into open bolt holes shown. Tighten the two bolts to release aluminum oil pan from cylinder block.

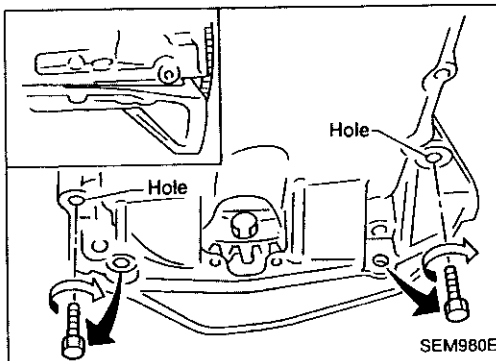

17. Remove aluminum oil pan.

(1) Insert Tool between cylinder block and aluminum oil pan.

- Be careful not to damage aluminum mating surface.
- Do not insert screwdriver, or oil pan flange will be deformed.

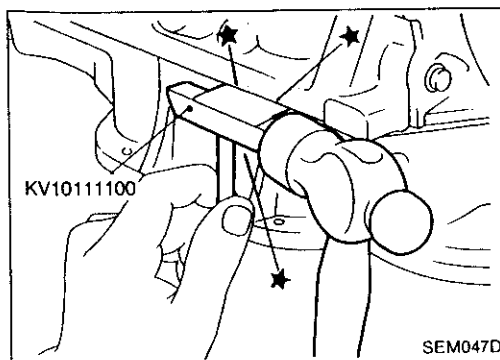
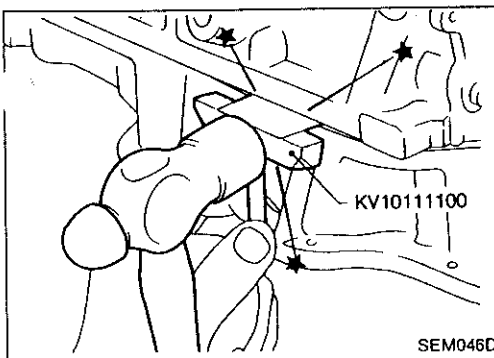

GI

MA

EM

LC

FC

FE

CL

MT

AT

PD

FA

RA

BR

ST

RS

BT

HA

EL

IDX

## OIL PAN

### Removal (Cont'd)

18. Remove the two oil pan-to-transmission bolts previously installed in aluminum oil pan.

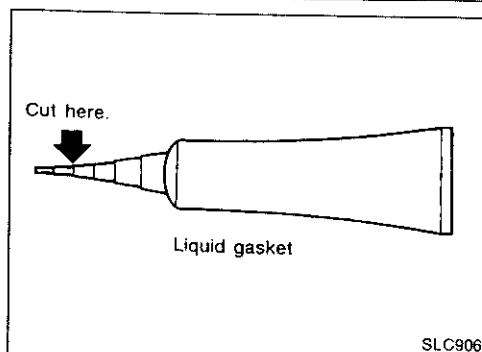
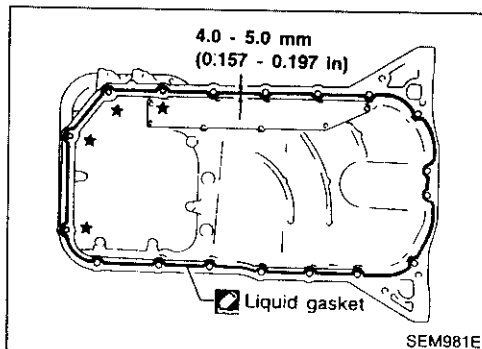
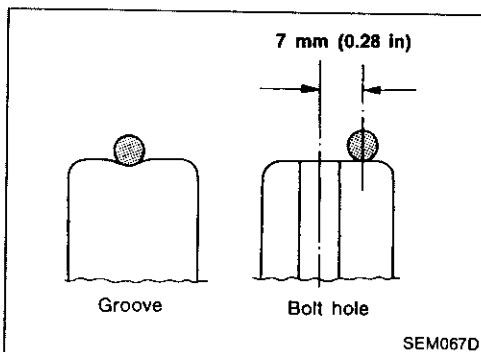
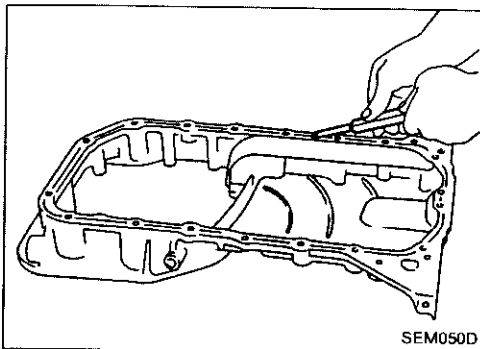
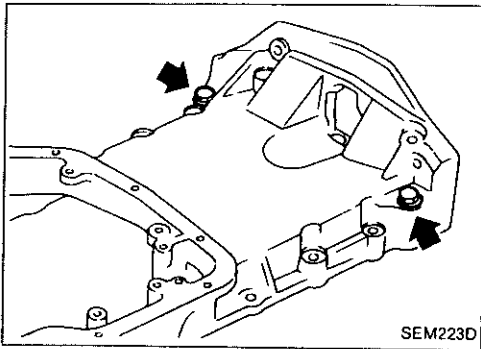

### Installation

1. Install aluminum oil pan.
  - (1) Before installing aluminum oil pan, remove all traces of liquid gasket from mating surfaces using a scraper.
    - Also remove traces of liquid gasket from mating surface of cylinder block and front cover.

- (2) Apply a continuous bead of liquid gasket to mating surface of aluminum oil pan.

- Use Genuine Liquid Gasket or equivalent.

- For areas marked with "★", apply liquid gasket to the outer side of the bolt hole.

- Be sure liquid gasket is 4.0 to 5.0 mm (0.157 to 0.197 in) wide.
- Attaching should be done within 5 minutes after coating.

## OIL PAN

### Installation (Cont'd)

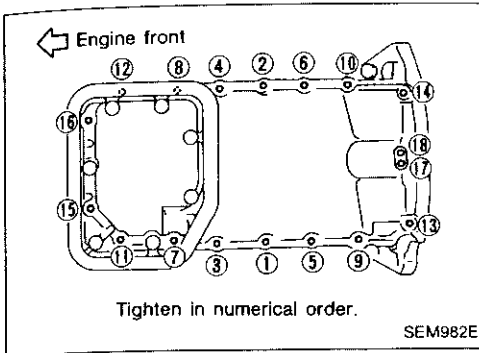

(3) Install aluminum oil pan.

- Tighten bolts in numerical order shown.

① - ⑯ bolts:

☐: 16 - 19 N·m (1.6 - 1.9 kg-m, 12 - 14 ft-lb)

⑰, ⑱ bolts:

☐: 6.4 - 7.5 N·m (0.65 - 0.76 kg-m, 4.7 - 5.5 ft-lb)

2. Install the four oil pan-to-transmission bolts.
3. Install rear cover plate.
4. Install alternator support.
5. Tighten front suspension member securing bolts.
6. Install all removed parts after removing steel oil pan.

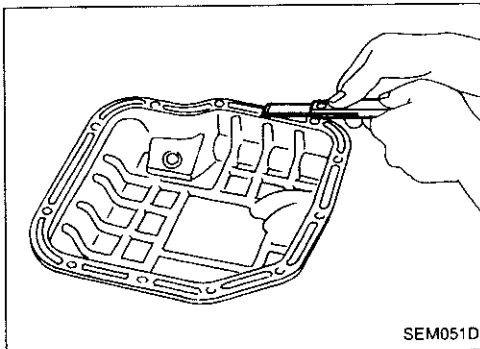

7. Install steel oil pan.

(1) Before installing steel oil pan, remove all traces of liquid gasket from mating surfaces using a scraper.

- Also remove traces of liquid gasket from mating surface of aluminum oil pan.

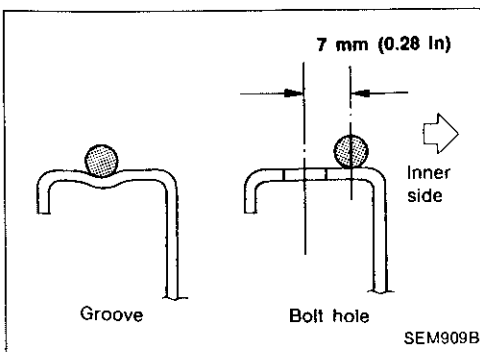

(2) Apply a continuous bead of liquid gasket to mating surface of steel oil pan.

- Use **Genuine Liquid Gasket** or equivalent.

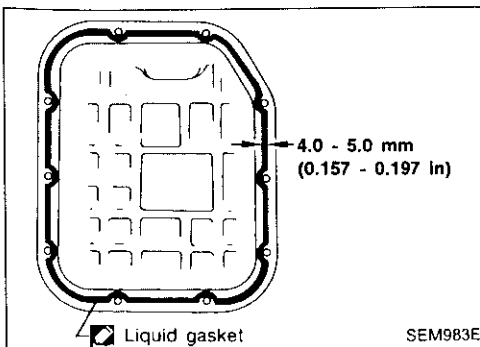

GI

MA

EM

LC

EC

FE

CL

MT

AT

PD

FA

RA

BR

ST

RS

BT

HA

EL

IDX

## OIL PAN

### Installation (Cont'd)

- Be sure liquid gasket is 4.0 to 5.0 mm (0.157 to 0.197 in) wide.
- Attaching should be done within 5 minutes after coating.

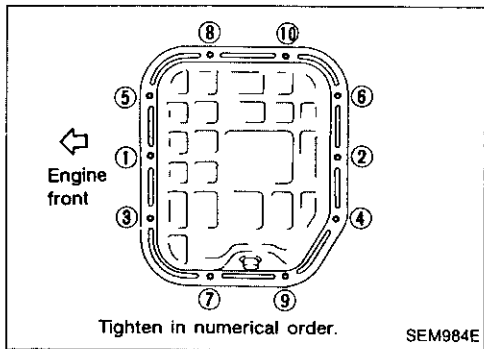
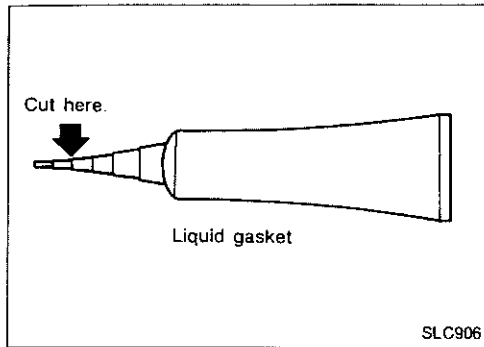

- (3) Install steel oil pan.
- Install bolts in numerical order shown.
- Wait at least 30 minutes before refilling engine oil.

# TIMING CHAIN

SEC. 120-130-135-210

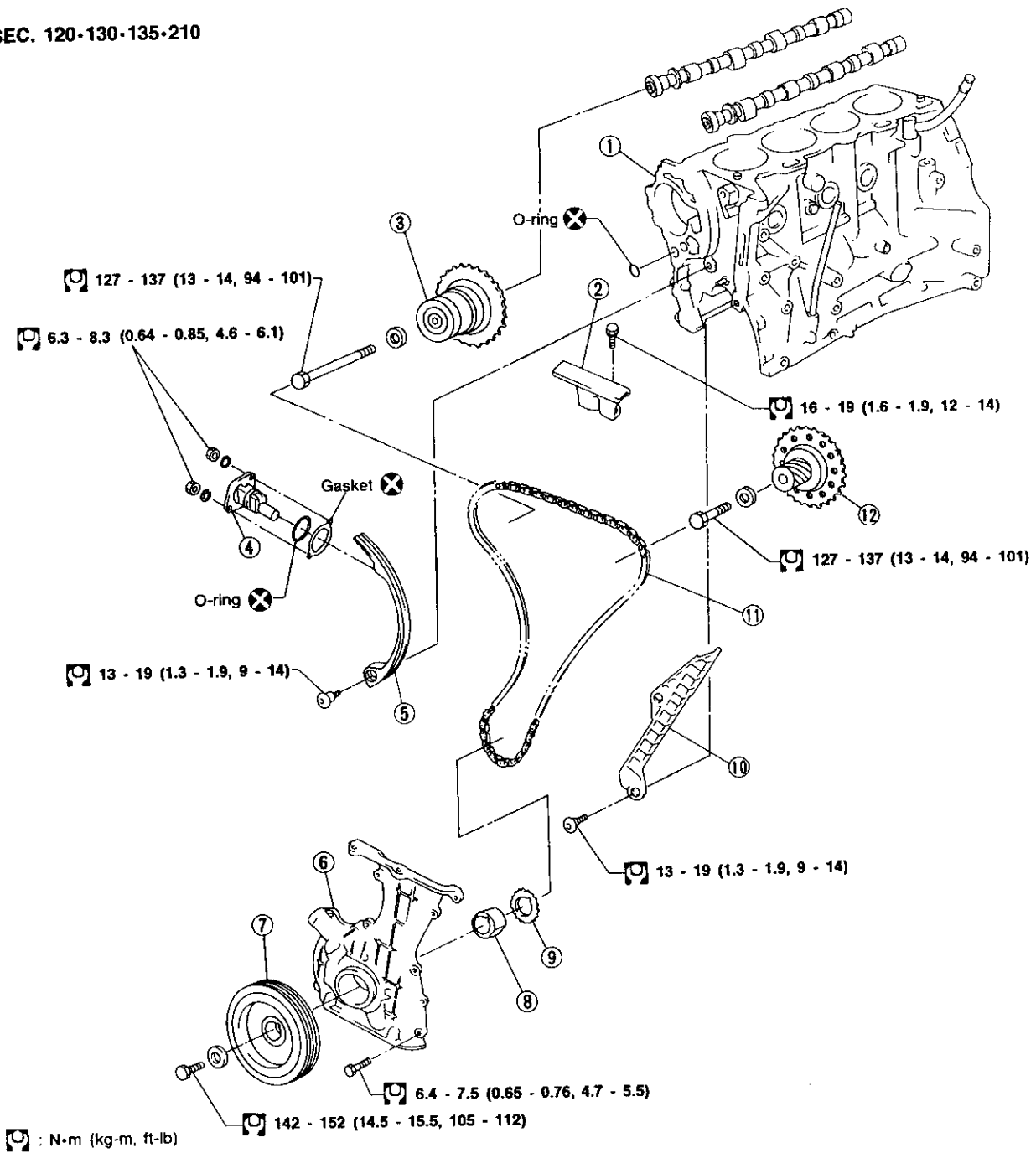

$\square$  : N·m (kg·m, ft·lb)

- ① Cylinder block
- ② Chain guide
- ③ RH camshaft sprocket
- ④ Chain tensioner

- ⑤ Chain guide
- ⑥ Front cover
- ⑦ Crank pulley
- ⑧ Oil pump spacer

- ⑨ Crankshaft sprocket
- ⑩ Chain guide
- ⑪ Timing chain
- ⑫ LH camshaft sprocket

GI

MA

**EM**

LC

EC

FE

CL

MT

AT

PD

FA

RA

BR

ST

RS

SEM985E

BT

HA

EL

IDX

## TIMING CHAIN

### Removal (Cont'd)

14. Set No. 1 piston at TDC on the compression stroke by rotating crankshaft.

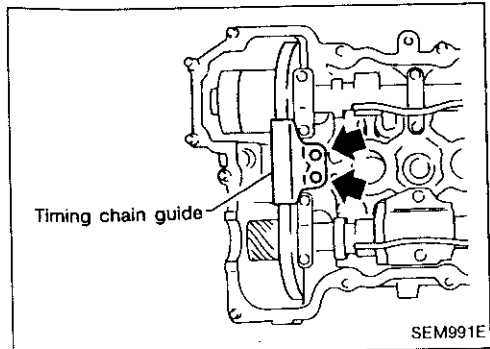
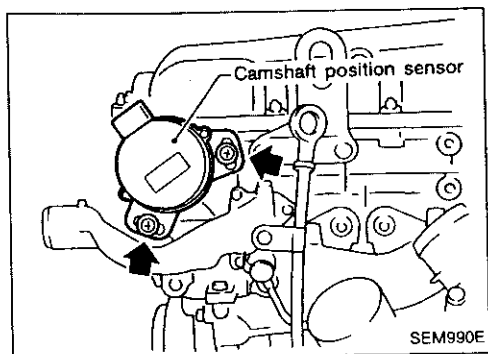
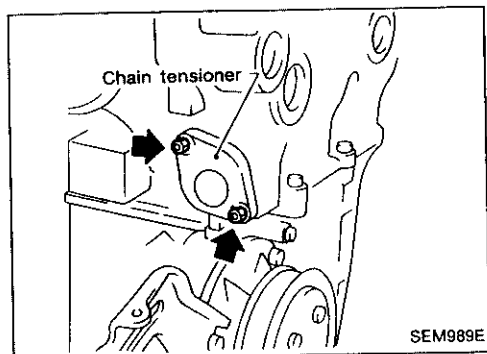
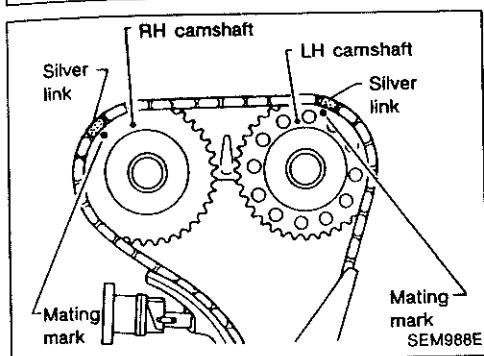
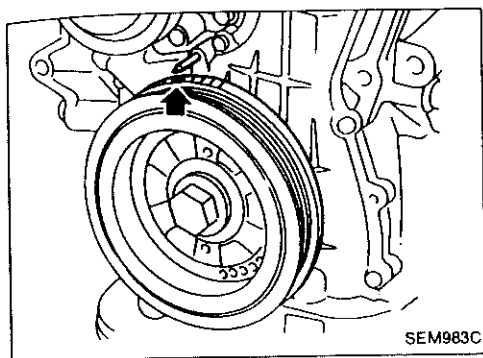

- Rotate crankshaft until mating mark on camshaft sprocket is set at position indicated in figure at left.

15. Remove chain tensioner.

16. Remove camshaft position sensor.

17. Remove timing chain guide.

GI

MA

EM

LC

EC

FE

CL

MT

AT

PD

FA

RA

BR

ST

RS

BT

HA

EL

IDX



## TIMING CHAIN

### CAUTION:

- After removing timing chain, do not turn crankshaft and camshaft separately, or valves will strike piston heads.
- When installing rocker arms, camshafts, chain tensioner, oil seals, or other sliding parts, lubricate contacting surfaces with new engine oil.
- Apply new engine oil to bolt threads and seat surfaces when installing cylinder head, camshaft sprocket, crankshaft pulley, and camshaft brackets.

### Removal

1. Release fuel pressure.  
Refer to "Releasing Fuel Pressure" in EC section.
2. Remove engine under covers.
3. Drain coolant.
4. Remove radiator.
5. Remove air duct to intake manifold and air recirculation duct.
6. Remove PCV hoses from rocker cover.
7. Remove drive belts and water pump pulley.
8. Remove alternator.
9. Remove power steering oil pump.
10. Remove the following parts from cylinder head and intake manifold: vacuum hoses, fuel hoses, water hoses, wires, harness, connectors and so on.
11. Remove ignition coils and all spark plugs.

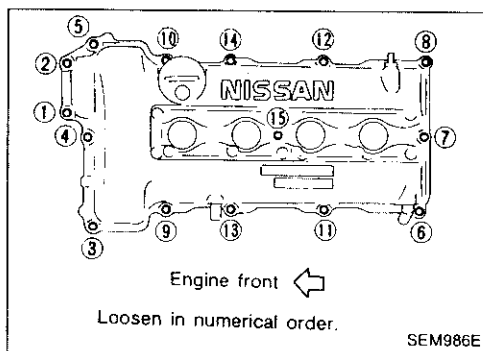

12. Remove rocker cover.

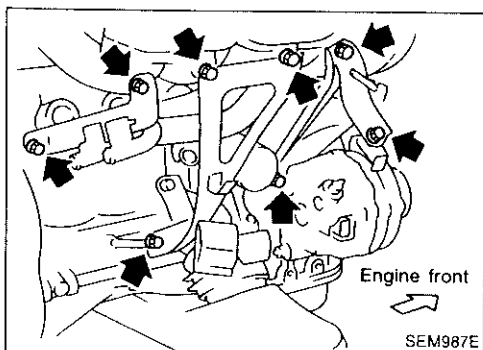

13. Remove intake manifold supports.

## TIMING CHAIN

### Removal (Cont'd)

14. Set No. 1 piston at TDC on the compression stroke by rotating crankshaft.

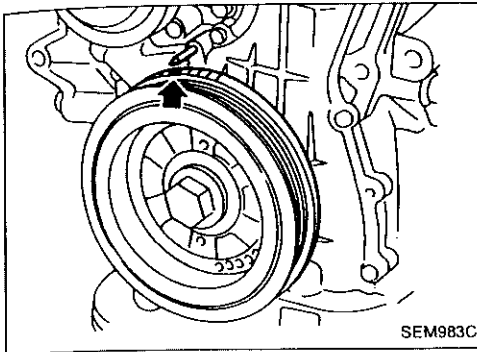

- Rotate crankshaft until mating mark on camshaft sprocket is set at position indicated in figure at left.

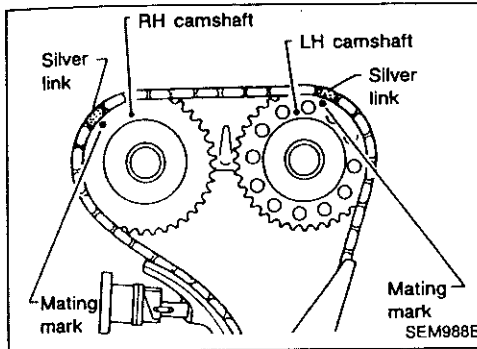

15. Remove chain tensioner.

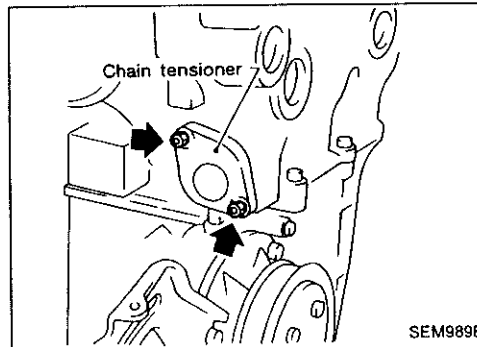

16. Remove camshaft position sensor.

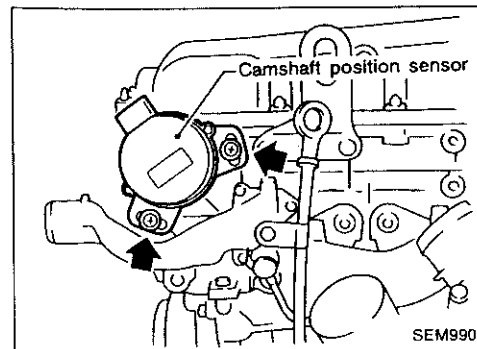

17. Remove timing chain guide.

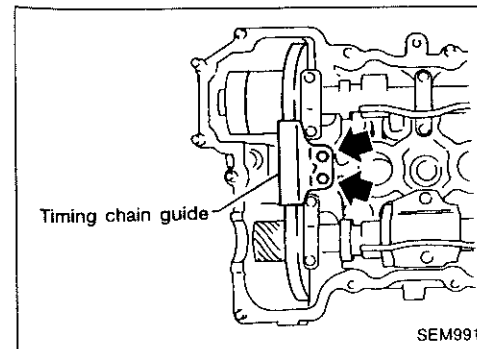

GI

MA

EM

LC

EC

FE

CL

MT

AT

PD

FA

RA

BR

ST

RS

BT

HA

EL

IDX

## TIMING CHAIN

### Removal (Cont'd)

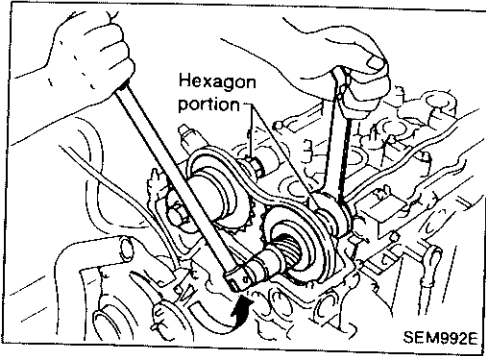

18. Remove camshaft sprockets.

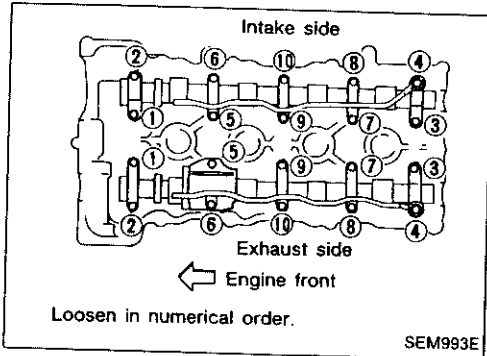

19. Remove camshafts, camshaft brackets, oil tubes and baffle plate.

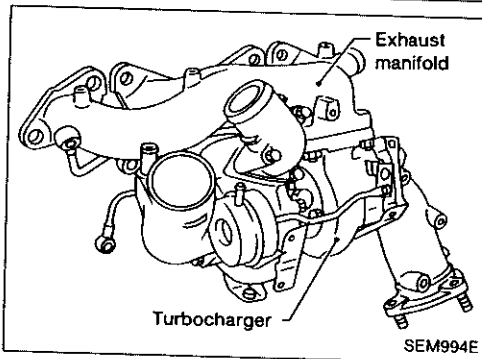

20. Remove exhaust manifold with turbocharger. Refer to "Removal" in "TURBOCHARGER" (EM-49).

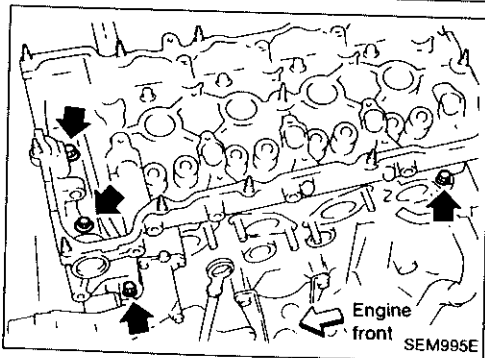

21. Remove cylinder head outside bolts and inside sub bolts.

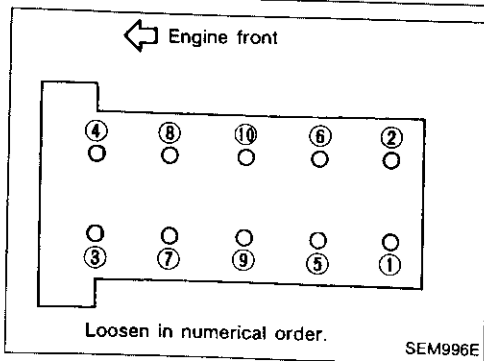

22. Remove cylinder head bolts.

- A warped or cracked cylinder head may result from removing in incorrect order.

- Bolts should be loosened in two or three steps.

23. Remove cylinder head with intake manifold.

## TIMING CHAIN

### Removal (Cont'd)

24. Remove oil pans.  
Refer to "Removal" in "OIL PAN" (EM-13).
25. Remove oil strainer and baffle plate.

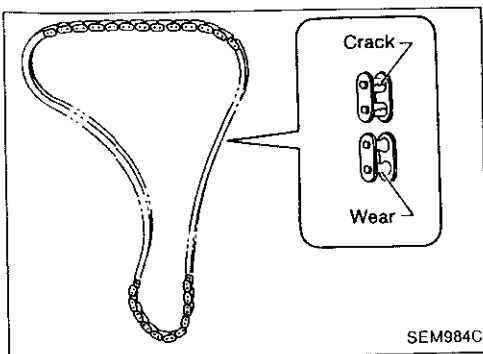
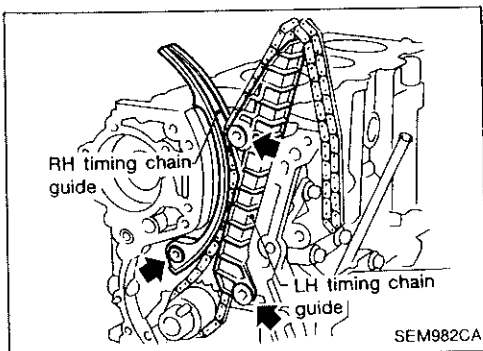
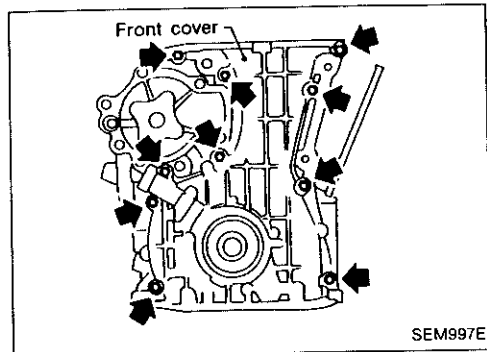
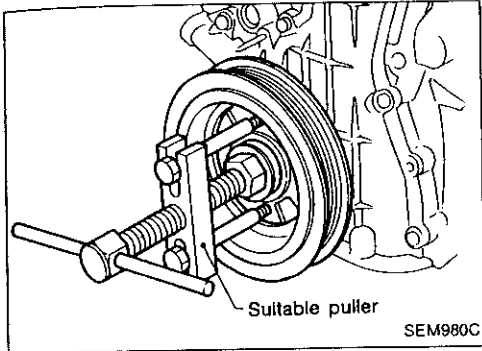
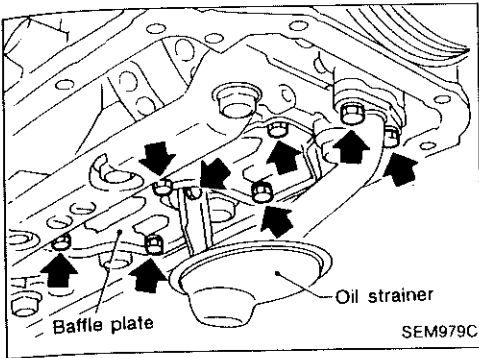

26. Remove crankshaft pulley.

27. Remove front cover.

28. Remove timing chain guides and timing chain.

### Inspection

Check for cracks and excessive wear at roller links. Replace chain if necessary.

GI

MA

EM

LC

EC

FE

CL

MT

AT

PD

FA

RA

BR

ST

RS

BT

HA

EL

IDX

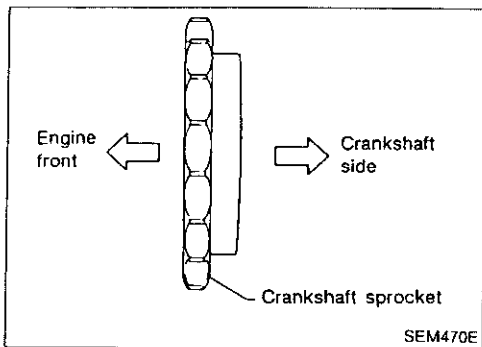

## Installation

1. Install crankshaft sprocket on crankshaft.

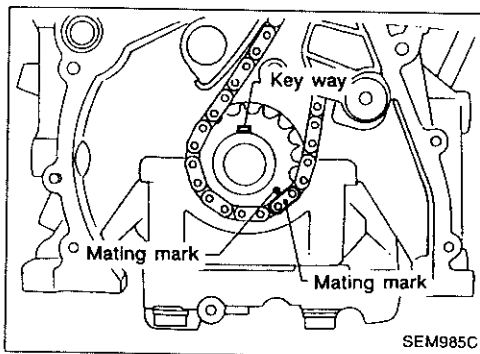

2. Position crankshaft so that No. 1 piston is set at TDC and key way is at 12 o'clock. Fit timing chain on crankshaft sprocket, aligning the mating marks.

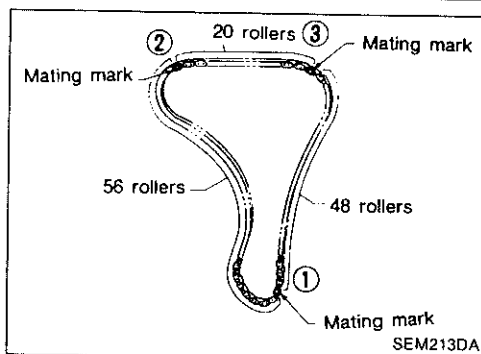

- Mating mark color on timing chain.

① : Gold  
 ②, ③ : Silver

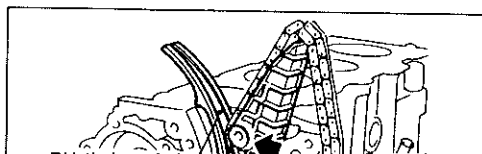

3. Install timing chain and timing chain guides.

## TIMING CHAIN

### Installation (Cont'd)

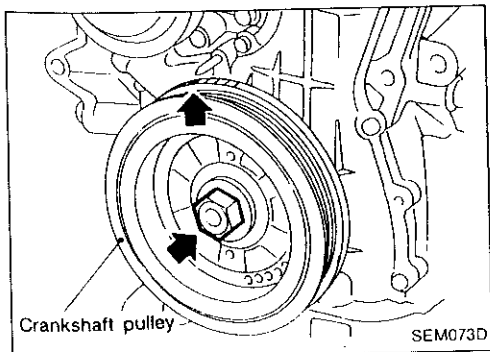
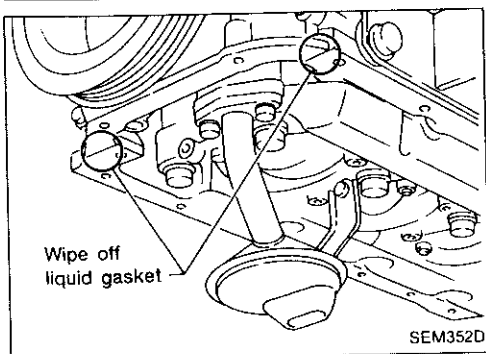
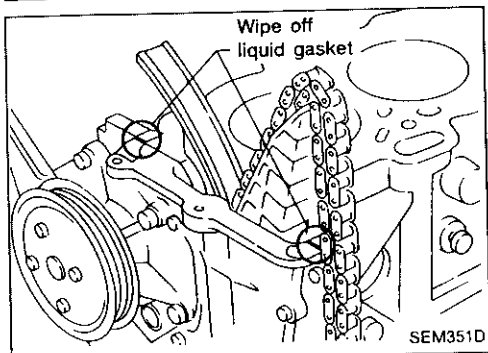
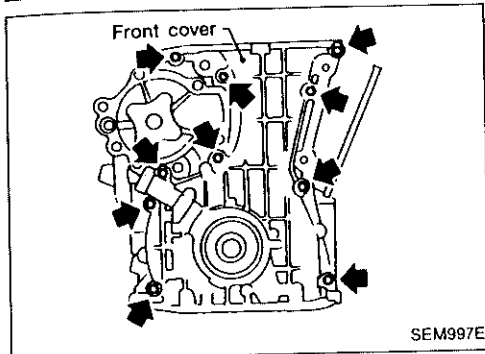
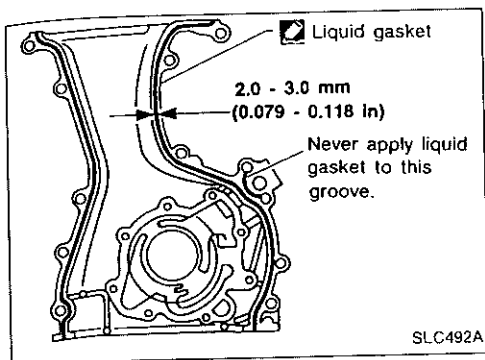

5. Apply a continuous bead of liquid gasket to mating surface of front cover.

- Use Genuine Liquid Gasket or equivalent.

6. Install oil pump drive spacer and front cover.

- Make sure that O-ring is installed on oil pump outlet passage of cylinder block.

- Wipe off excessive liquid gasket.

7. Install crankshaft pulley.

8. Set No. 1 piston at TDC on its compression stroke.

GI

MA

EM

LC

EC

EE

CL

MT

AT

PD

FA

RA

BR

ST

RS

BT

HA

EL

DX

## TIMING CHAIN

### Installation (Cont'd)

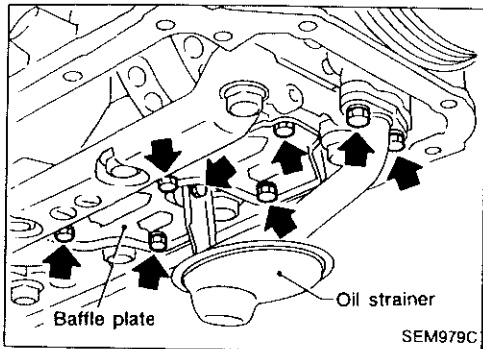

9. Install oil strainer and baffle plate.

10. Install oil pan.  
Refer to "Installation" in "OIL PAN" (EM-13).

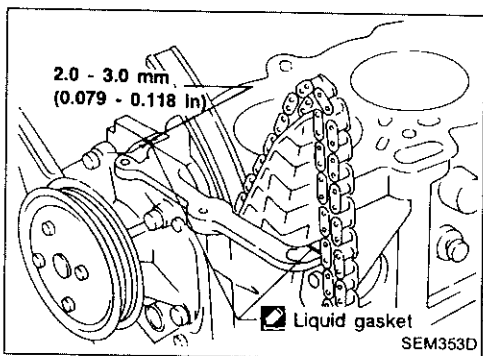

11. Before installing cylinder head gasket, apply a continuous bead of liquid gasket to mating surface of cylinder block.

Cylinder head bolt

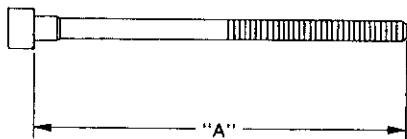

SEM020D

12. Install cylinder head with intake manifold.

#### CAUTION:

The cylinder head bolts can be reused providing dimension "A" is not exceeded.

Dimension "A":  
158.2 mm (6.23 in)

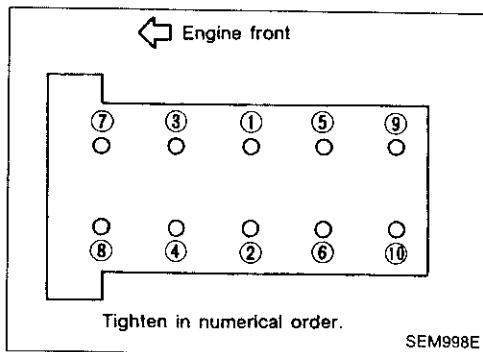

- Cylinder head bolts tightening procedure:
  - a. Tighten all bolts to 39 N·m (4.0 kg-m, 29 ft-lb).
  - b. Tighten all bolts to 78 N·m (8.0 kg-m, 58 ft-lb).
  - c. Loosen all bolts completely.
  - d. Tighten all bolts to 34 to 44 N·m (3.5 to 4.5 kg-m, 25 to 33 ft-lb).

## TIMING CHAIN

### Installation (Cont'd)

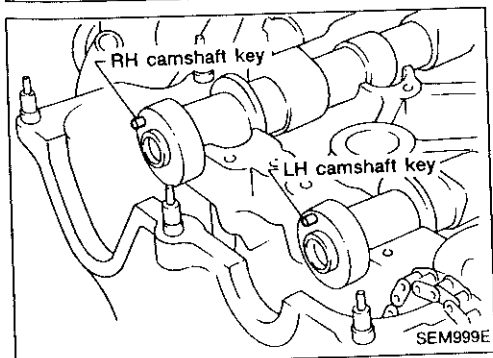
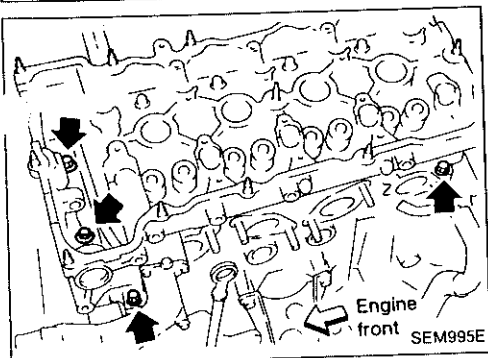
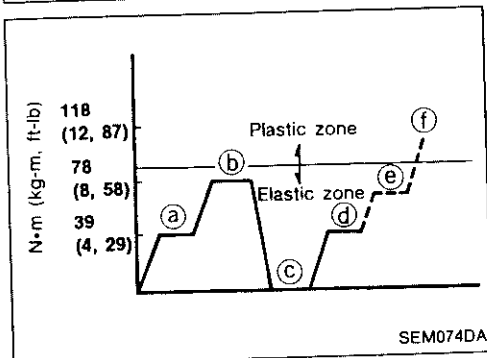
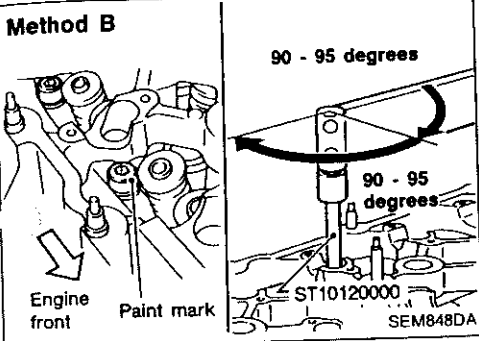
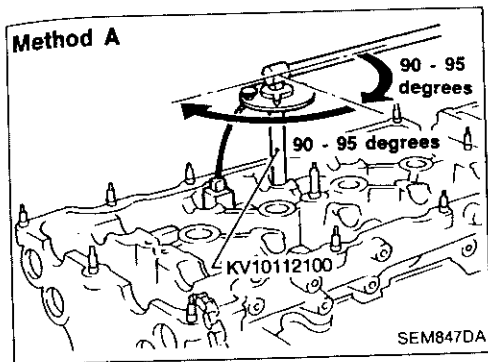

e. Method A: Turn all bolts 90 to 95 degrees clockwise with Tool or suitable angle wrench.

Method B: If an angle wrench is not available, mark all cylinder head bolts on the side facing engine front. Then, turn each cylinder head bolt 90 to 95 degrees clockwise.

f. Turn all bolts 90 to 95 degrees clockwise.

g. Ensure that paint mark on each bolt faces the rear of the engine. (Method B only)

Do not turn any bolt 180 to 190 degrees clockwise all at once.

	Tightening torque N-m (kg-m, ft-lb)
a	39 (4.0, 29)
b	78 (8.0, 58)
c	0 (0, 0)
d	39 ± 5 (4.0 ± 0.5, 28.9 ± 3.6)
e	90 <sup>+5</sup> <sub>-0</sub> degrees
f	90 <sup>+5</sup> <sub>-0</sub> degrees

13. Install cylinder head outside bolts and inner sub-bolts.

14. Install exhaust manifold with turbocharger. Refer to "Installation" in "TURBOCHARGER" (EM-53).

15. Install camshafts, camshaft brackets, oil tubes and baffle plate.

- Position camshaft.
  - a. LH camshaft key at about 12 o'clock
  - b. RH camshaft key at about 10 o'clock

GI  
MA  
EM  
LC  
EC  
FE  
CL  
MT  
AT  
PD  
FA  
RA  
BR  
ST  
RS  
BT  
HA  
EL  
IDX



## TIMING CHAIN

### Installation (Cont'd)

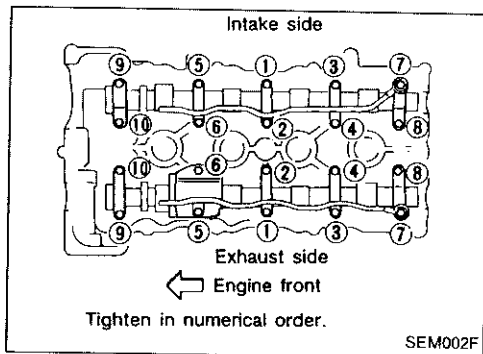
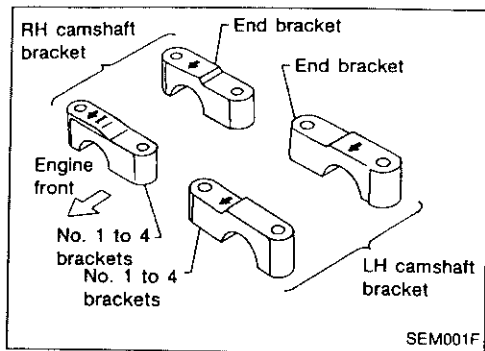

- Position camshaft bracket.

- Camshaft bracket bolts tightening procedure

#### STEP 1:

Tighten bolts ⑨ - ⑩ in that order then tighten bolts ① - ⑧ in that order.

Ⓜ: 2 N·m (0.2 kg-m, 1.4 ft-lb)

#### STEP 2:

Tighten bolts in the specified order.

Ⓜ: 6 N·m (0.6 kg-m, 4.3 ft-lb)

#### STEP 3:

Tighten bolts in the specified order.

Ⓜ: 9.0 - 11.8 N·m

(0.92 - 1.2 kg-m, 6.7 - 8.7 ft-lb)

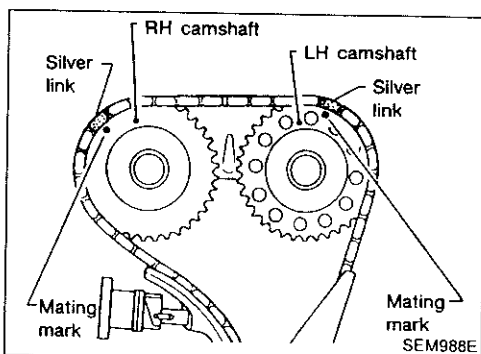

- 16. Install camshaft sprockets.

Line up mating marks on timing chain with mating marks on camshaft sprockets.

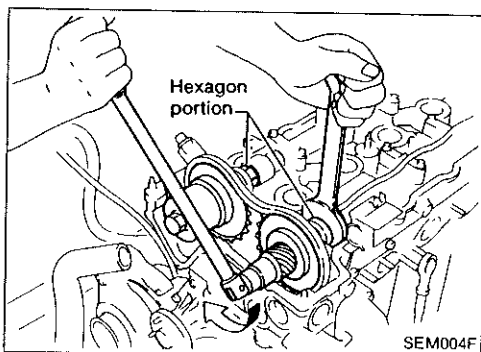

- Lock camshafts as shown in figure and tighten to specified torque.

Ⓜ: 127 - 137 N·m

(13 - 14 kg-m, 94 - 101 ft-lb)

## TIMING CHAIN

### Installation (Cont'd)

17. Install timing chain guide.

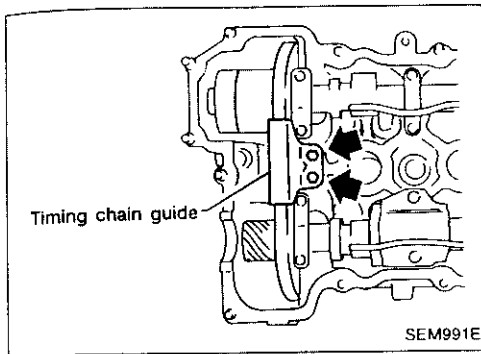

18. Install camshaft position sensor.

- Make sure that No. 1 piston is at TDC on its compression stroke.
- Set mating marks on rotor shaft of camshaft position sensor as shown.

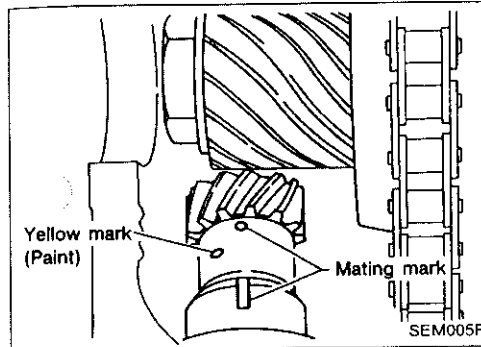

c. Install camshaft position sensor aligning the center of fixing bolt hole.

- After installing, confirm that mating marks on rotor shaft of camshaft position sensor are as shown.
- Tighten fixing bolts.

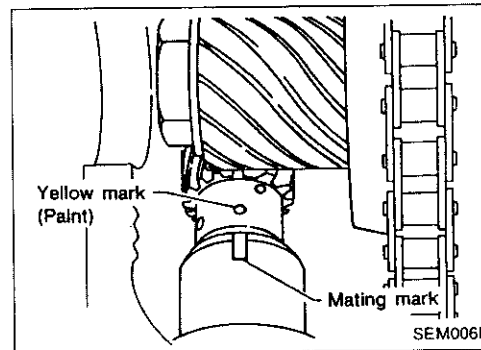

19. Install chain tensioner.

Press cam stopper down and "press-in" sleeve until hook can be engaged on pin. When tensioner is bolted in position the hook will release automatically. Ensure arrow "A" faces the front of the engine.

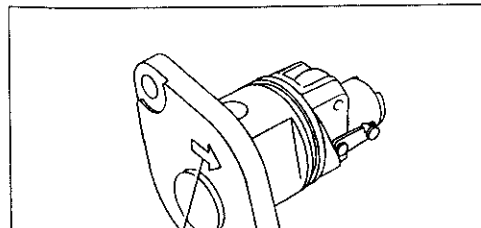
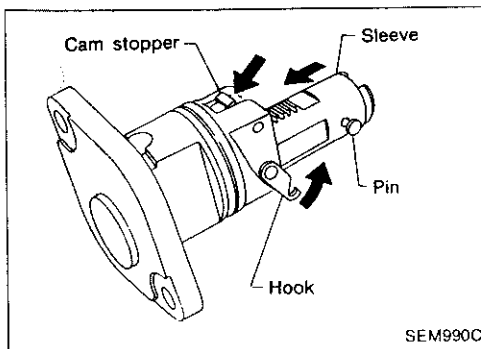

GI

MA

EM

LC

EC

FE

CL

MT

AT

PD

FA

RA

BR

ST

RS

BT

HA

EL

FX

## TIMING CHAIN

### Installation (Cont'd)

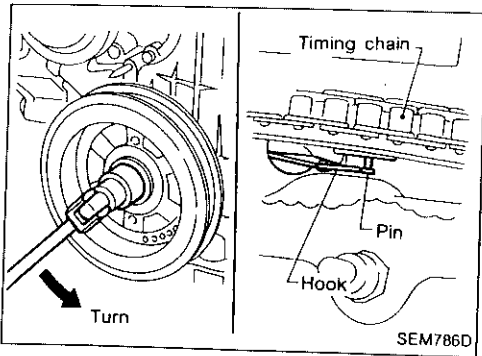

- If hook does not release automatically, turn crankshaft counterclockwise until it does release.

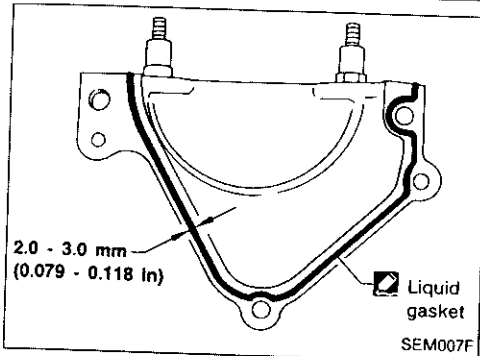

20. Install cylinder head front cover.
  - Before installing, remove all traces of liquid gasket from mating surface of cylinder head and the cover using a scraper.
  - Apply a continuous bead of liquid gasket to mating surface of cylinder head front cover.
  - Use **Genuine Liquid Gasket or equivalent**.

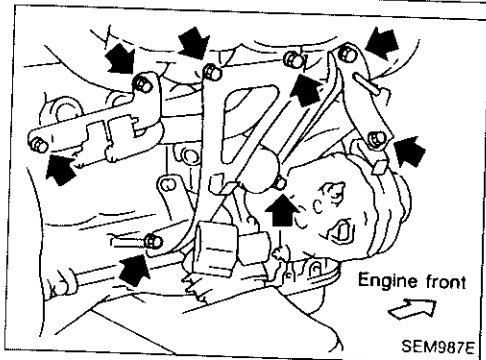

21. Install intake manifold supports.

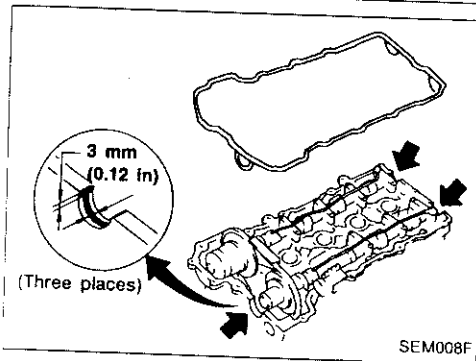

22. Remove all old liquid gasket from mating surfaces of rocker cover and cylinder head.
23. Apply a continuous bead of liquid gasket to mating surface of rocker cover gasket and cylinder head.
  - Use **Genuine Liquid Gasket or equivalent**.

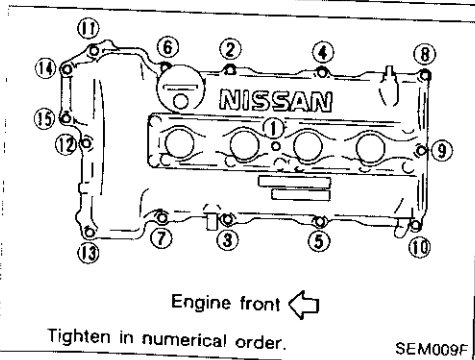

24. Install rocker cover.
 

**Rocker cover tightening procedure:**

  - (1) Tighten nuts ① - ⑩ - ⑪ - ⑬ - ⑧ in that order to 4 N·m (0.4 kg-m, 2.9 ft-lb).
  - (2) Tighten nuts ① to ⑬ as indicated in figure to 8 to 10 N·m (0.8 to 1.0 kg-m, 5.8 to 7.2 ft-lb).

## TIMING CHAIN

### Installation (Cont'd)

25. Reinstall any parts removed in reverse order of removal.
- When refilling engine coolant, refer to "Engine Maintenance" in MA section.

GI

MA

**EM**

LC

EC

FE

CL

MT

AT

PD

FA

RA

BR

ST

RS

BT

HA

EL

IDX

## OIL SEAL REPLACEMENT

### VALVE OIL SEAL

1. Remove rocker cover.
2. Remove camshafts and sprockets.  
Refer to "Removal" in "TIMING CHAIN" (EM-20).
3. Remove ignition coils on spark plugs.

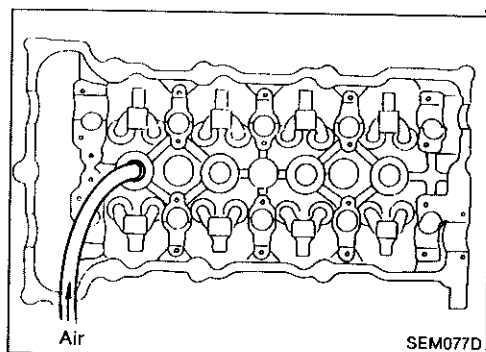

4. Install air hose adapter into spark plug hole and apply air pressure to hold valves in place. Apply a pressure of 490 kPa (4.9 bar, 5 kg/cm<sup>2</sup>, 71 psi).
5. Remove rocker arm, rocker arm guide and shim.

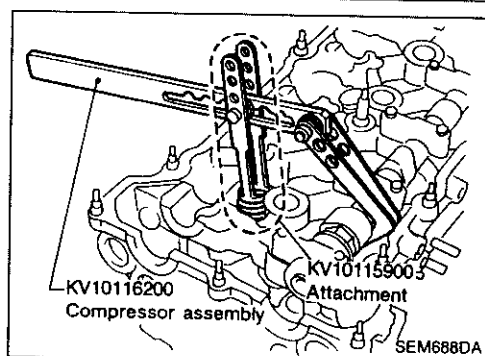

6. Remove valve spring with Tool.  
**Piston concerned should be set at TDC to prevent valve from falling.**

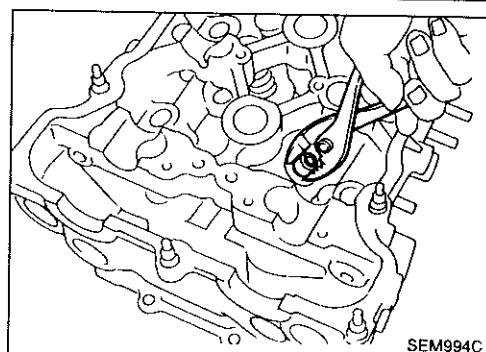

7. Remove valve oil seal.



8. Apply engine oil to new valve oil seal and install it with Tool.

# OIL SEAL REPLACEMENT

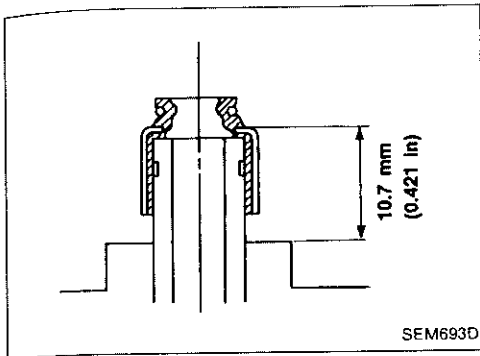

## FRONT OIL SEAL

1. Remove the following parts:
  - Engine under cover
  - Drive belts
  - Crankshaft pulley

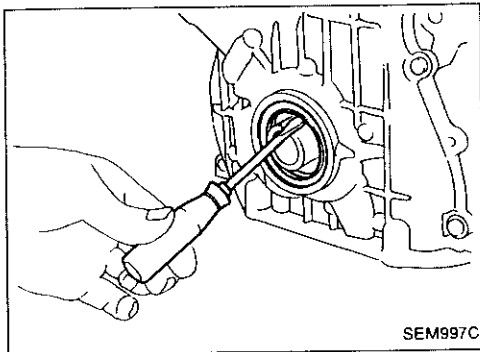

2. Remove front oil seal.  
**Be careful not to scratch front cover.**

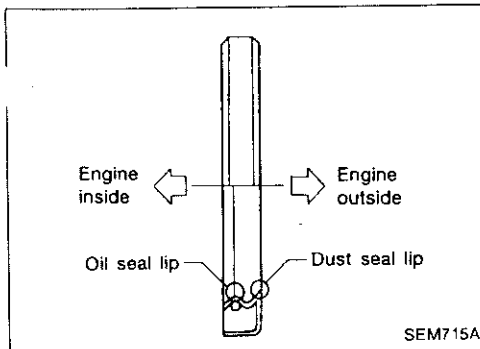

3. Apply engine oil to new oil seal and install it using a suitable tool.

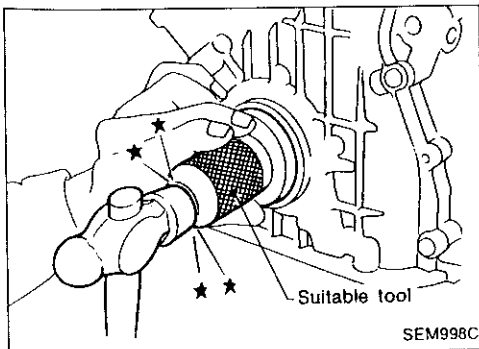

GI

WA

**EM**

LC

EC

FE

CL

MT

AT

PD

FA

RA

BR

ST

RS

BT

HA

EL

IDX

## OIL SEAL REPLACEMENT

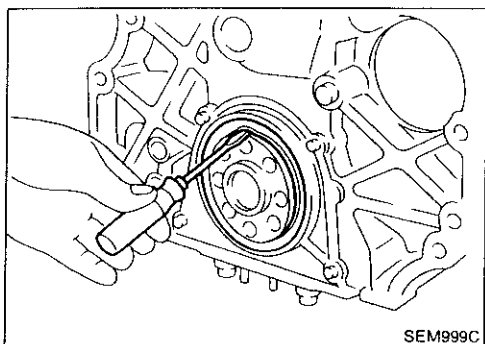

SEM999C

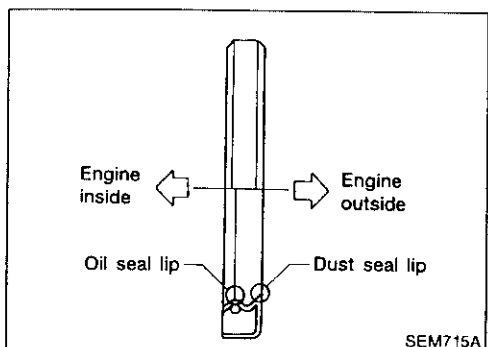

SEM715A

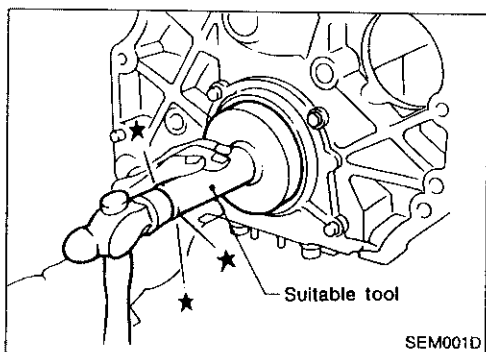

SEM001D

### REAR OIL SEAL

1. Remove transmission. (Refer to MT or AT section.)
2. Remove flywheel or drive plate.
3. Remove rear oil seal.

**Be careful not to scratch rear oil seal retainer.**

4. Apply engine oil to new oil seal and install it using a suitable tool.

# INTAKE MANIFOLD

## Removal

1. Release fuel pressure.  
Refer to "Releasing Fuel Pressure" in EC section.
2. Drain coolant.
3. Remove air duct from intake manifold.
4. Remove PCV hoses from rocker cover.
5. Remove vacuum hoses, fuel hoses, water hoses, wires, harnesses, connectors, etc. from intake manifold.

GI

MA

**EM**

LC

EC

FE

CL

MT

AT

PD

FA

RA

BR

ST

RS

BT

HA

EL

DX

6. Remove intake manifold collector supports.

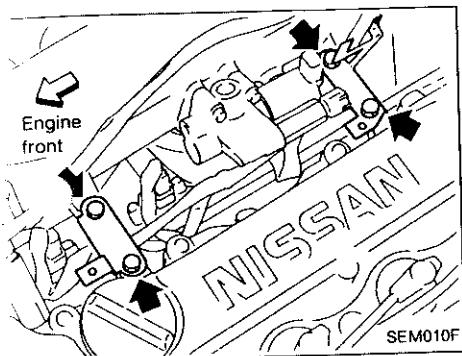

7. Remove intake manifold collector.

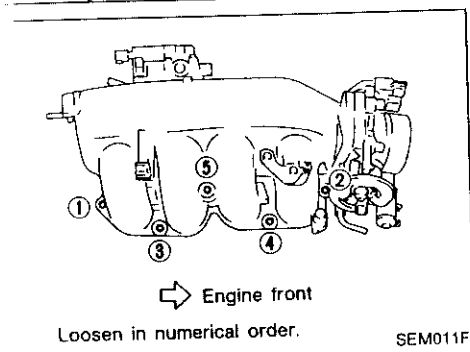

8. Remove harness connectors of engine coolant temperature sensor and thermal transmitter.
9. Remove fuel tube assembly.

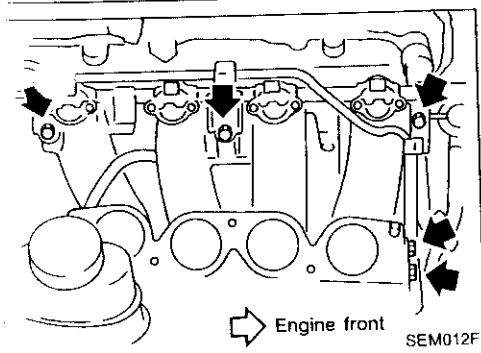

10. Remove EGR tube.
11. Remove hose and tube between EGR valve and EGRC-BPT valve.

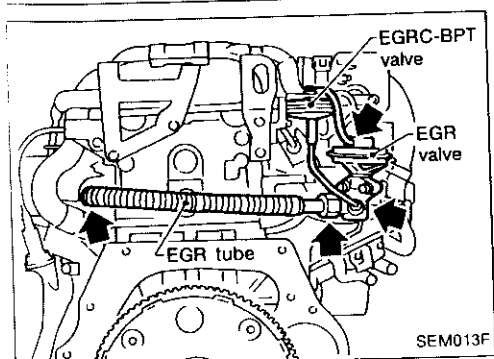



## INTAKE MANIFOLD

### Removal (Cont'd)

12. Remove intake manifold supports.

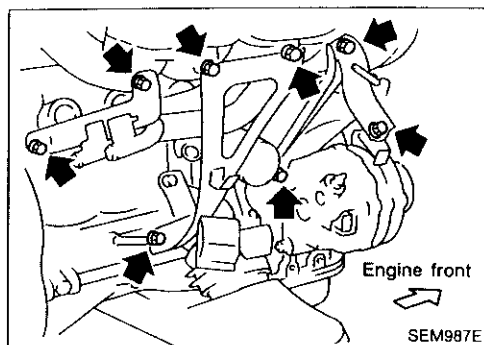

13. Remove intake manifold.

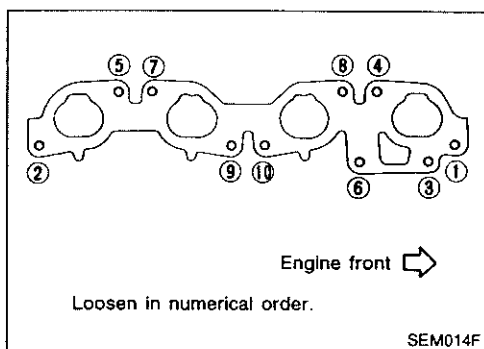

### Installation

1. Install intake manifold.
2. Install intake manifold supports.
3. Install EGR tube.
4. Install hose and tube between EGR valve and EGRC-BPT valve.

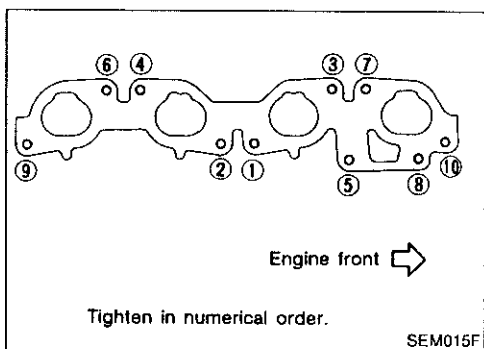

5. Install fuel tube assembly.
- **Tighten bolts in two steps.**
  - 1st: 9.3 - 10.8 N·m (0.95 - 1.1 kg-m, 6.9 - 8.0 ft-lb)
  - 2nd: 21 - 26 N·m (2.1 - 2.7 kg-m, 15 - 20 ft-lb)
6. Connect harness connectors of engine coolant temperature sensor and thermal transmitter.

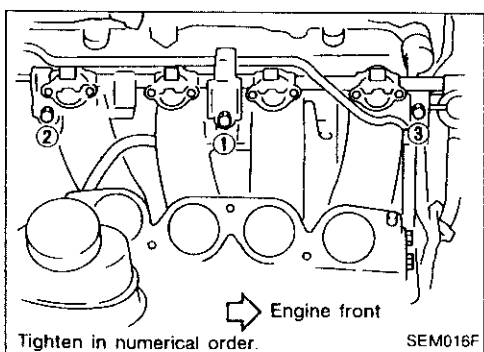

7. Install intake manifold collector.

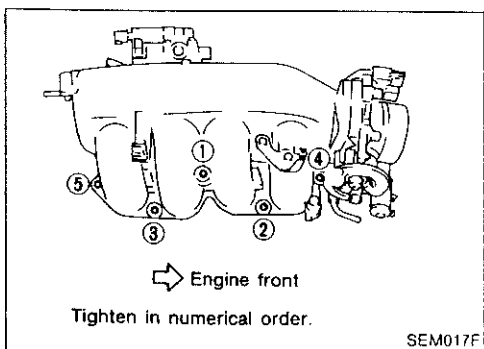

# INTAKE MANIFOLD

## Installation (Cont'd)

8. Reinstall any parts removed in reverse order of removal.

GI

MA

**EM**

LC

EC

FE

CL

MT

AT

PD

FA

RA

BR

ST

RS

BT

HA

EL

IDX

# CYLINDER HEAD

SEC. 111-130

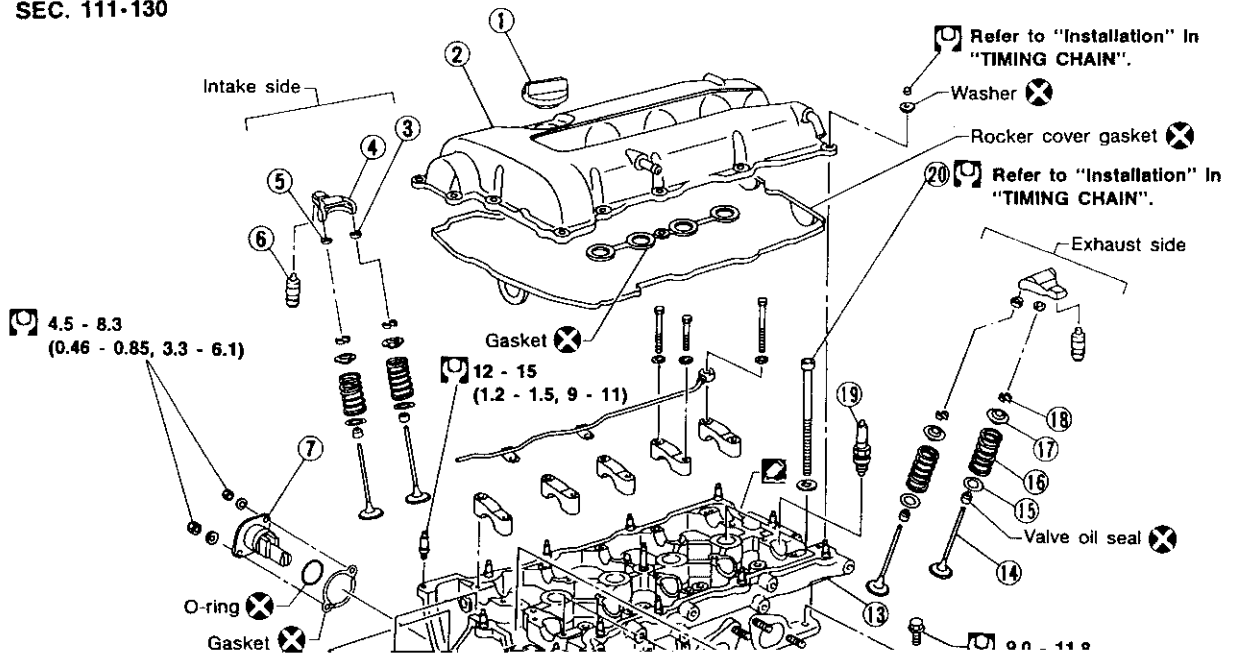

## CYLINDER HEAD

### CAUTION:

- When installing rocker arms, camshaft and oil seal, lubricate contacting surfaces with new engine oil.
- When tightening cylinder head bolts, camshaft sprocket bolts and camshaft bracket bolts, lubricate thread portions and seat surfaces of bolts with new engine oil.

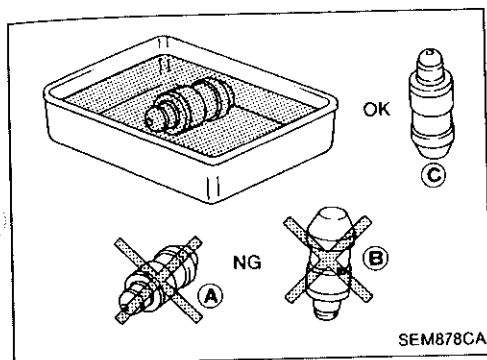

- If a hydraulic lash adjuster is kept on its side, there is a risk of air entering it. When hydraulic lash adjusters are removed, stand them straight up or soak them in new engine oil.
- Do not disassemble hydraulic lash adjusters.
- Attach tags to lash adjusters so as not to mix them up.

### Removal and Installation

Removal and installation procedures are the same as those for timing chain. Refer to "Removal" and "Installation" in "TIMING CHAIN" (EM-20, EM-24).

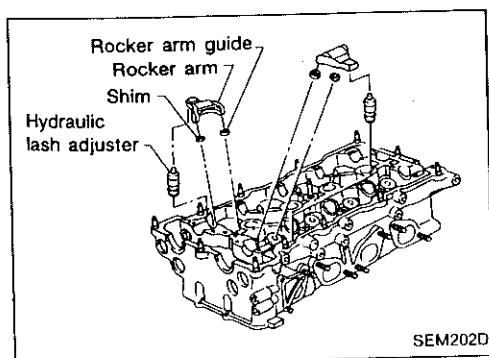

### Disassembly

1. Remove rocker arms, shims, rocker arm guides and hydraulic lash adjusters from cylinder head.

### CAUTION:

Keep parts in order so that they can be installed in their original positions during assembly. (Install parts in their original positions.)

2. Remove intake manifold. Refer to "Removal" in "INTAKE MANIFOLD" (EM-35).
3. Remove water outlet.

## CYLINDER HEAD

### Disassembly (Cont'd)

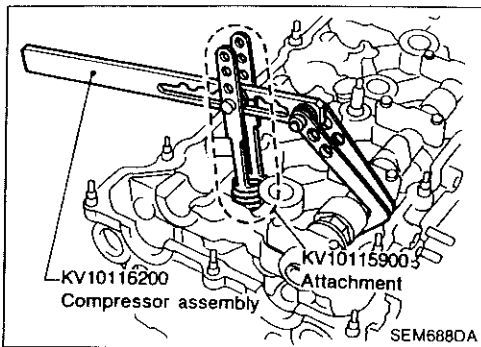

4. Remove valve components with Tool.

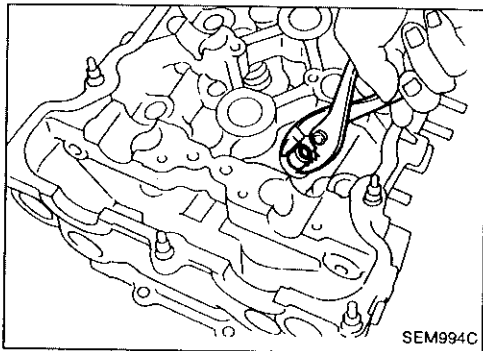

5. Remove valve oil seal with a suitable tool.

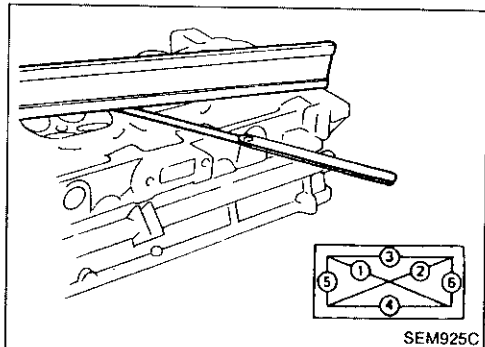

### Inspection

#### CYLINDER HEAD DISTORTION

Measure the distortion in the directions as shown.

##### Head surface distortion:

**Standard**

Less than 0.03 mm (0.0012 in)

**Limit**

0.1 mm (0.004 in)

If beyond the specified limit, replace or resurface.

##### Resurfacing limit:

The resurfacing limit of cylinder head is determined by the cylinder block resurfacing in an engine.

Amount of cylinder head resurfacing is "A".

Amount of cylinder block resurfacing is "B".

The maximum limit is as follows:

$A + B = 0.2 \text{ mm (0.008 in)}$

After resurfacing cylinder head, check that camshaft rotates freely by hand. If resistance is felt, cylinder head must be replaced.

**Nominal cylinder head height:**

136.9 - 137.1 mm (5.390 - 5.398 in)

#### CAMSHAFT VISUAL CHECK

Check camshaft for scratches, seizure and wear.

## CYLINDER HEAD

### Inspection (Cont'd)

#### CAMSHAFT RUNOUT

1. Measure camshaft runout at the center journal.

**Runout (Total indicator reading):**

**Standard**

Less than 0.02 mm (0.0008 in)

**Limit**

0.1 mm (0.004 in)

2. If it exceeds the limit, replace camshaft.

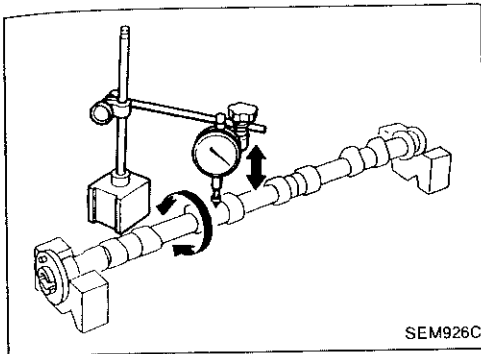

#### CAMSHAFT CAM HEIGHT

1. Measure camshaft cam height.

**Standard cam height:**

**Intake & Exhaust**

37.920 - 38.110 mm (1.4929 - 1.5004 in)

**Cam wear limit:**

**Intake & Exhaust**

0.20 mm (0.0079 in)

2. If wear is beyond the limit, replace camshaft.

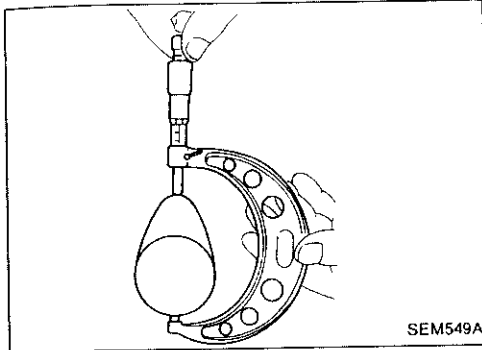

#### CAMSHAFT JOURNAL CLEARANCE

1. Install camshaft bracket and tighten bolts to the specified torque.

2. Measure inner diameter of camshaft bearing.

**Standard inner diameter:**

28.000 - 28.021 mm (1.1024 - 1.1032 in)

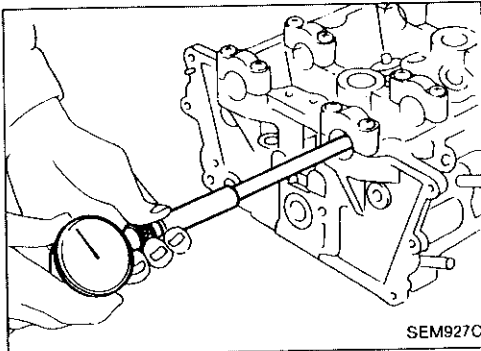

3. Measure outer diameter of camshaft journal.

**Standard outer diameter:**

27.935 - 27.955 mm (1.0998 - 1.1006 in)

4. If clearance exceeds the limit, replace camshaft and/or cylinder head.

**Camshaft journal clearance:**

**Standard**

0.045 - 0.086 mm (0.0018 - 0.0034 in)

**Limit**

0.15 mm (0.0059 in)

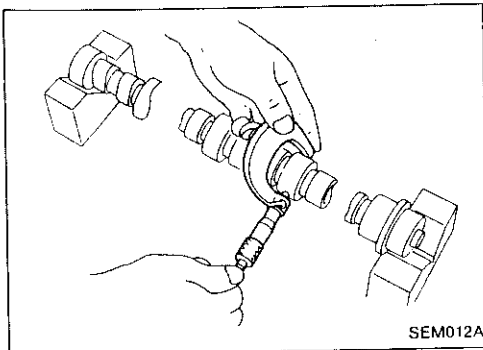

#### CAMSHAFT END PLAY

1. Install camshaft in cylinder head.

2. Measure camshaft end play.

**Camshaft end play:**

**Standard**

0.092 - 0.173 mm (0.0036 - 0.0068 in)

**Limit**

0.20 mm (0.0079 in)

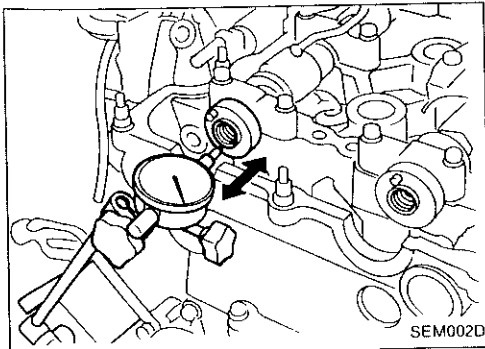

GF

MA

EM

LC

EC

FE

CL

MT

AT

PD

FA

RA

BR

ST

RS

BT

HA

EL

IX

## CYLINDER HEAD

### Inspection (Cont'd)

#### CAMSHAFT SPROCKET RUNOUT

1. Install sprocket on camshaft.
2. Measure camshaft sprocket runout.  
**Runout (Total indicator reading):**  
**Limit 0.25 mm (0.0098 in)**
3. If it exceeds the limit, replace camshaft sprocket.

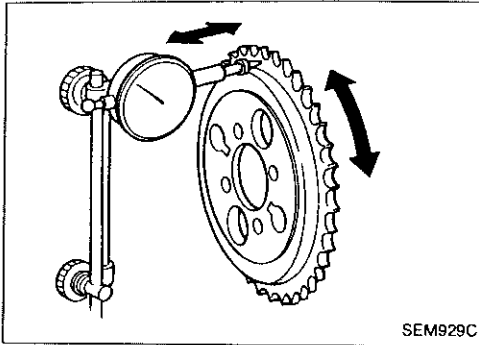

#### VALVE GUIDE CLEARANCE

1. Measure valve deflection in a parallel direction with rocker arm. (Valve and valve guide mostly wear in this direction.)  
**Valve deflection limit (Dial gauge reading):**  
**Intake & Exhaust**  
**0.2 mm (0.008 in)**

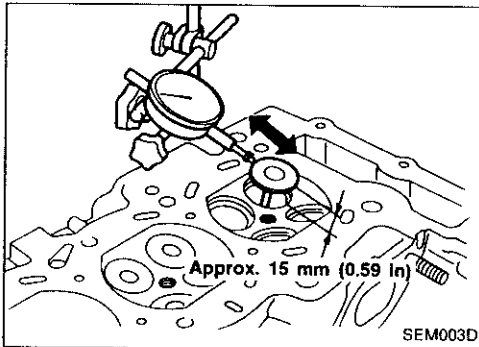

2. If it exceeds the limit, check valve to valve guide clearance.
    - a. Measure valve stem diameter and valve guide inner diameter.
    - b. Check that clearance is within specification.
- Valve to valve guide clearance:**

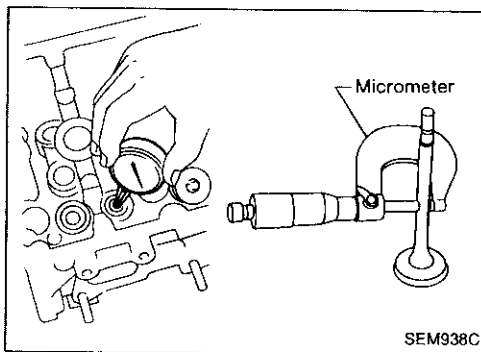

Unit: mm (in)

	Standard	Limit
Intake	0.020 - 0.053 (0.0008 - 0.0021)	0.08 (0.0031)
Exhaust	0.040 - 0.073 (0.0016 - 0.0029)	0.1 (0.004)

- c. If it exceeds the limit, replace valve or valve guide.

#### VALVE GUIDE REPLACEMENT

1. To remove valve guide, heat cylinder head to 110 to 130°C (230 to 266°F).

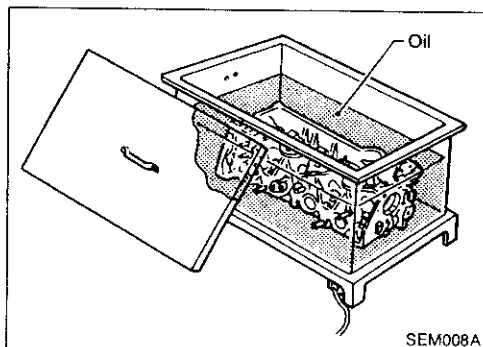

## CYLINDER HEAD

### Inspection (Cont'd)

2. Press out valve guide or use a hammer and suitable tool.

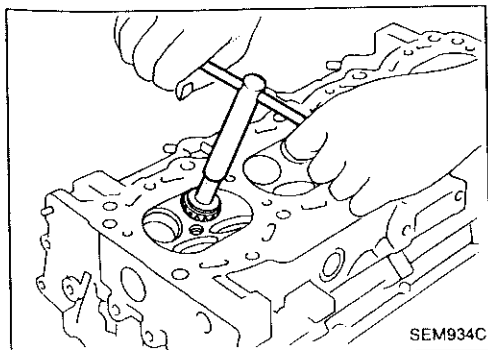
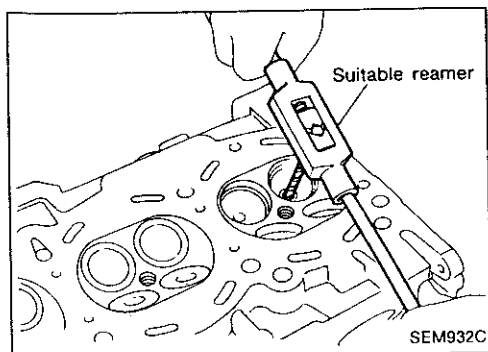
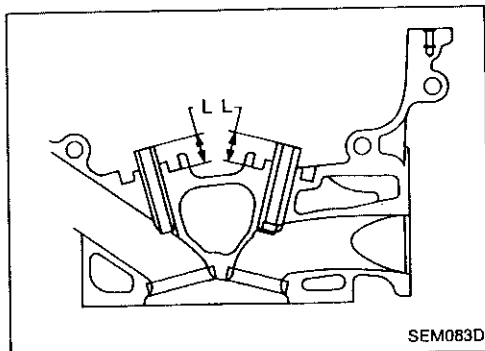
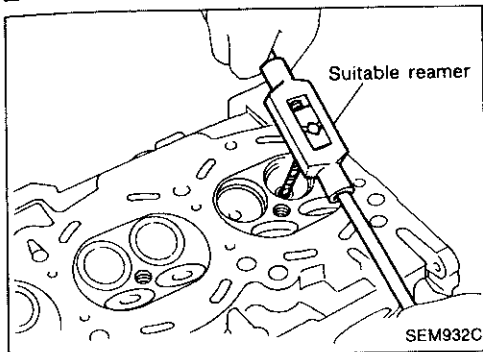
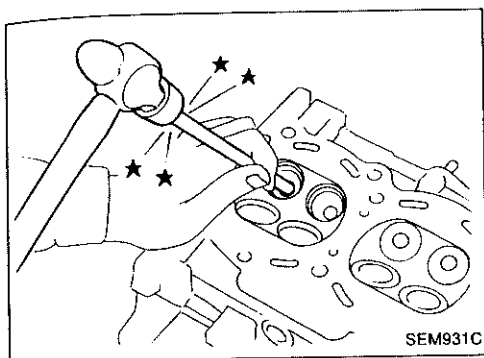

3. Ream cylinder head valve guide hole.

#### Valve guide hole diameter

(for service parts):

Intake

10.175 - 10.196 mm (0.4006 - 0.4014 in)

Exhaust

11.175 - 11.196 mm (0.4400 - 0.4408 in)

4. Heat cylinder head to 110 to 130°C (230 to 266°F) and press service valve guide onto cylinder head.

Projection "L":

14.0 - 14.2 mm (0.551 - 0.559 in)

5. Ream valve guide.

Valve guide inner diameter:

Intake

6.000 - 6.018 mm (0.2362 - 0.2369 in)

Exhaust

7.000 - 7.018 mm (0.2756 - 0.2763 in)

### VALVE SEATS

Check valve seats for pitting at contact surface. Resurface or replace if excessively worn.

- Before repairing valve seats, check valve and valve guide for wear. If they have worn, replace them. Then correct valve seat.
- Cut with both hands to uniform the cutting surface.

GI

MA

EM

LC

EC

FE

CL

MT

AT

PD

FA

RA

BR

ST

RS

BT

HA

EL

IDX



## CYLINDER HEAD

### Inspection (Cont'd)

#### REPLACING VALVE SEAT FOR SERVICE PARTS

1. Bore out old seat until it collapses. Set machine depth stop so that boring cannot contact bottom face of seat recess in cylinder head.

2. Ream cylinder head recess.

#### Reaming bore for service valve seat

Oversize [0.5 mm (0.020 in)]:

##### Intake

35.500 - 35.516 mm (1.3976 - 1.3983 in)

##### Exhaust

31.500 - 31.516 mm (1.2402 - 1.2408 in)

Use the valve guide center for reaming to ensure valve seat will have the correct fit.

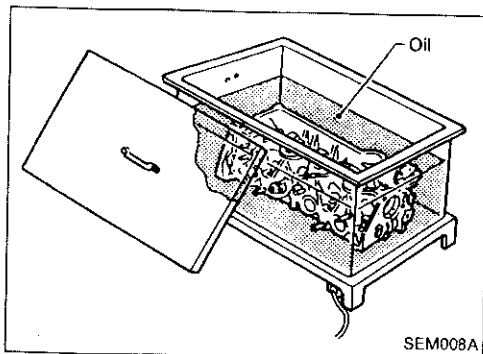
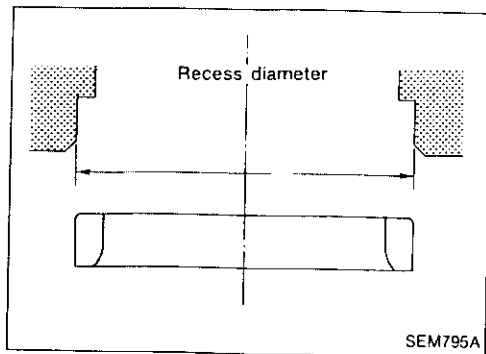

3. Heat cylinder head to 110 to 130°C (230 to 266°F).
4. Press fit valve seat until it seats on the bottom.

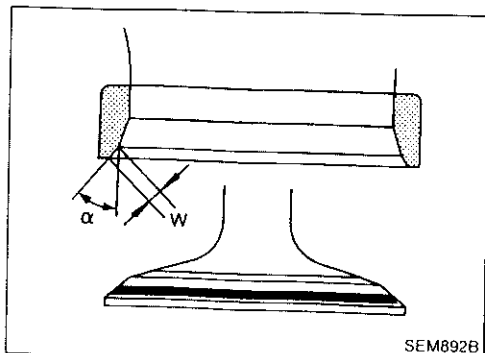

5. Cut or grind valve seat using a suitable tool at the specified dimensions as shown in SDS.
6. After cutting, lap valve seat with abrasive compound.
7. Check valve seating condition.

#### Seat face angle " $\alpha$ ":

44°53' - 45°07' deg.

#### Contacting width "W":

##### Intake

1.4 - 1.7 mm (0.055 - 0.067 in)

##### Exhaust

1.7 - 2.0 mm (0.067 - 0.079 in)

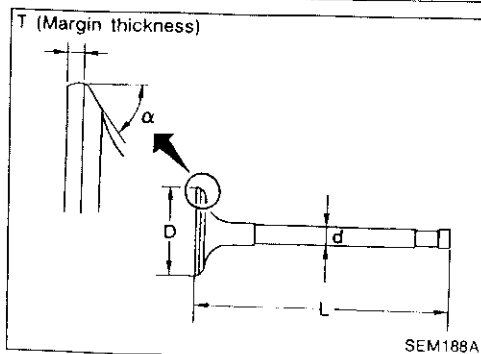

#### VALVE DIMENSIONS

Check dimensions in each valve. For dimensions, refer to SDS.

When valve head has been worn down to 0.5 mm (0.020 in) in margin thickness, replace valve.

Grinding allowance for valve stem tip is 0.2 mm (0.008 in) or less.

## CYLINDER HEAD

### Inspection (Cont'd)

#### VALVE SPRING

##### Squareness

1. Measure "S" dimension.  
**Out-of-square:**  
Less than 2.2 mm (0.087 in)
2. If it exceeds the limit, replace spring.

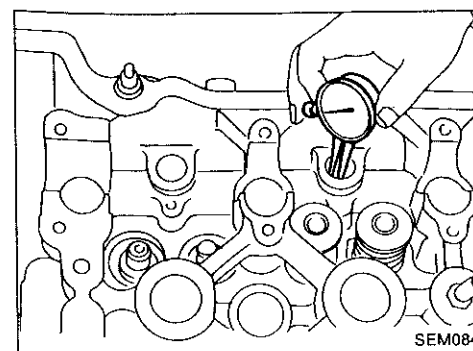
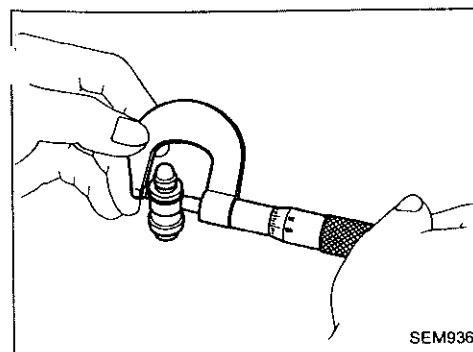
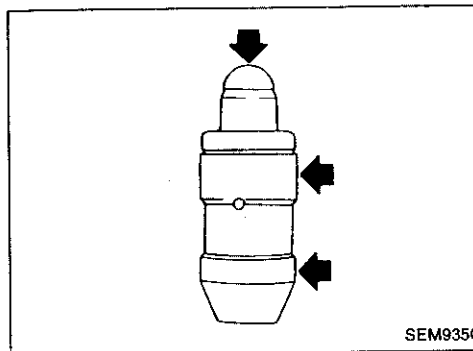
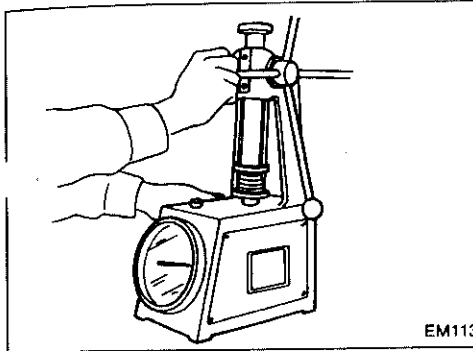
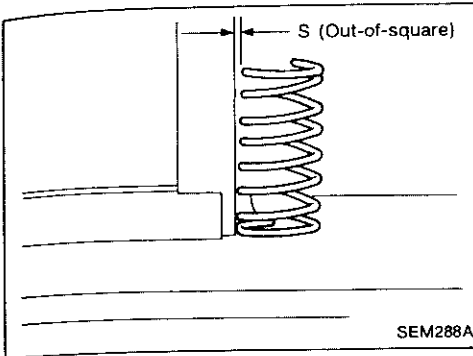

##### Pressure

Check valve spring pressure.

##### Standard:

578.02 - 641.57 N  
(58.94 - 65.42 kg, 129.96 - 144.25 lb)  
at 30.0 mm (1.181 in)

##### Limit:

More than 549.2 N (56.0 kg, 123.5 lb)  
at 30.0 mm (1.181 in)

If it exceeds the limit, replace spring.

#### HYDRAULIC LASH ADJUSTER

1. Check contact and sliding surfaces for wear or scratches.

2. Check diameter of lash adjuster.

##### Outer diameter:

16.980 - 16.993 mm (0.6685 - 0.6690 in)

3. Check lash adjuster guide inner diameter.

##### Inner diameter:

17.000 - 17.020 mm (0.6693 - 0.6701 in)

**Standard clearance between lash adjuster and  
adjuster guide:**

0.007 - 0.040 mm (0.0003 - 0.0016 in)

GI

MA

EM

LC

EC

FE

CL

MT

AT

PD

FA

RA

BR

ST

RS

BT

HA

EL

IDX

## CYLINDER HEAD

### Inspection (Cont'd)

#### ROCKER ARM, SHIM AND ROCKER ARM GUIDE

Check contact and sliding surfaces of rocker arms, shims and rocker arm guides for wear or scratches.

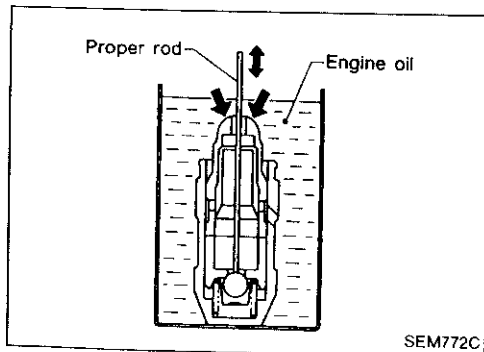
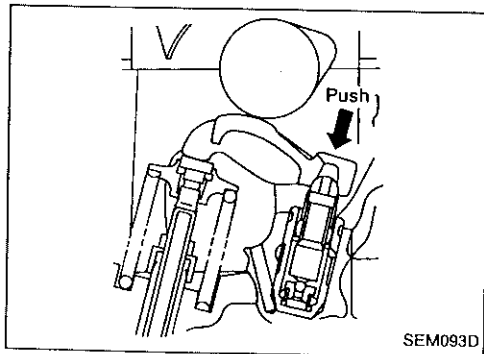
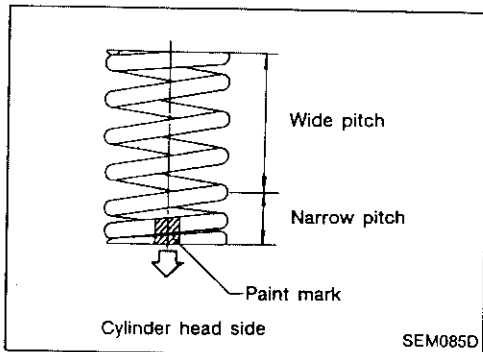
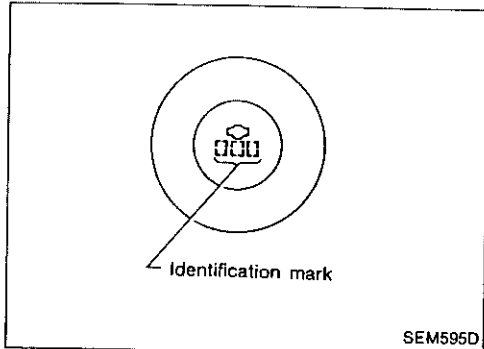
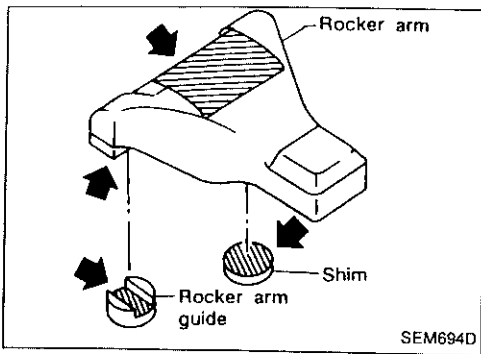

### Assembly

1. Install valve component parts.
  - Install valves, noting their identification marks as indicated in the table below.

Valve	Identification mark
Intake valve	53J
Exhaust valve	5J

- Always use new valve oil seal. Refer to OIL SEAL REPLACEMENT.
- Before installing valve oil seal, install valve spring seat.
- Install valve spring (uneven pitch type) with its narrow pitched side toward cylinder head side (paint mark).
- After installing valve components, tap valve stem tip with a plastic hammer to assure a proper fit.

2. Check hydraulic lash adjusters.
  - a. Push on the rocker arm above the hydraulic lash adjuster. If it moves 1 mm (0.04 in) or more, there is air in the high pressure chamber. Noise will be emitted from hydraulic lash adjuster if engine is started without bleeding air.

- b. Remove hydraulic lash adjuster and dip in a container filled with engine oil. While pushing plunger as shown in figure, lightly push check ball using a thin rod. Air is completely bled when plunger no longer moves.

**Air cannot be bled from this type of lash adjuster by running the engine.**

## CYLINDER HEAD

### Assembly (Cont'd)

3. Install rocker arms, shims, rocker arm guides and hydraulic lash adjusters.

#### CAUTION:

Install all parts in their original positions.

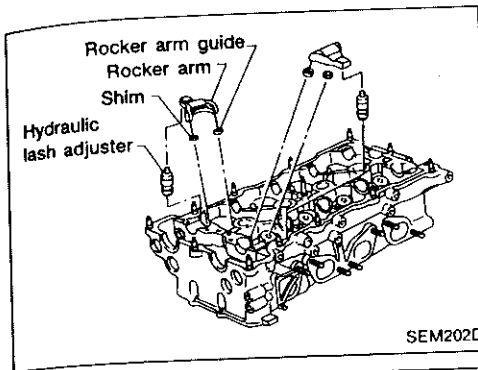

### Valve shim clearance adjustment

4. Determine proper shim size when replacing valve, cylinder head, shim, rocker arm guide, or valve seat.
- Install valve component parts to cylinder head (Except shim).
    - Always replace rocker arm guide with a new one.

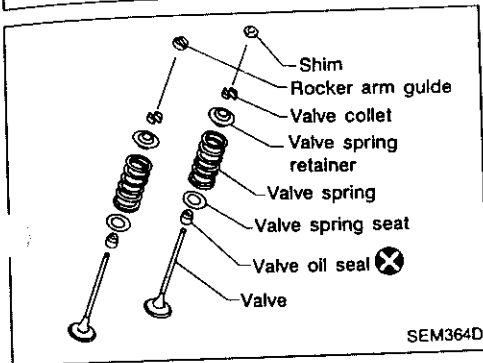

- Remove hydraulic lash adjuster.

- Install Tool\* into hydraulic lash adjuster fixing hole.

\* Tool (KV10115700) is screwed into magnetic stand rod used with dial gauge.

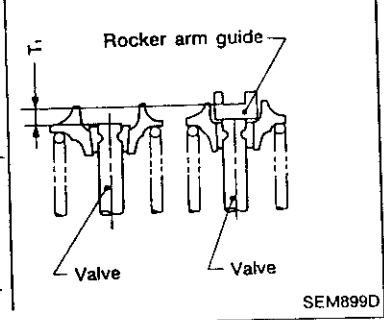
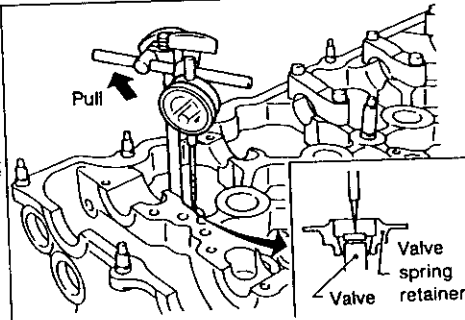
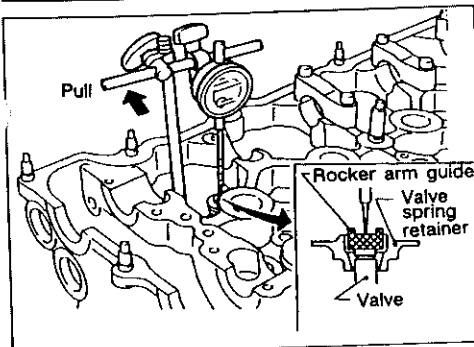
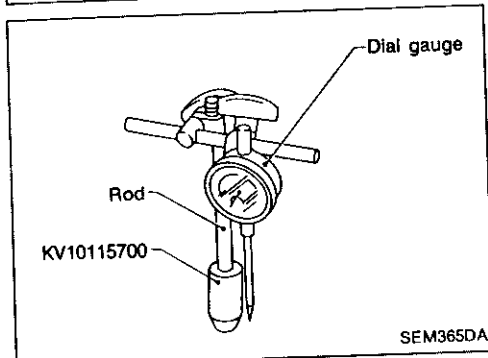

- Before measuring, make sure the following parts are installed in the cylinder head: valve, valve spring, collet, retainer, and rocker arm guide (except shim). On shim side, measure difference ( $T_1$ ) between contact surfaces of rocker arm guide and valve stem end.

When measuring, lightly pull dial indicator rod toward you to eliminate play in Tool (KV10115700).

GI

MA

EM

LC

EC

FE

CL

MT

AT

PD

FA

RA

BR

ST

RS

BT

HA

EL

IDX

## CYLINDER HEAD

### Assembly (Cont'd)

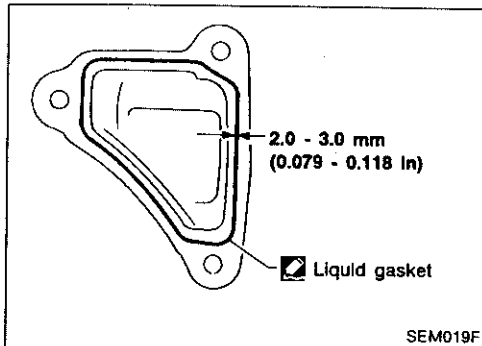
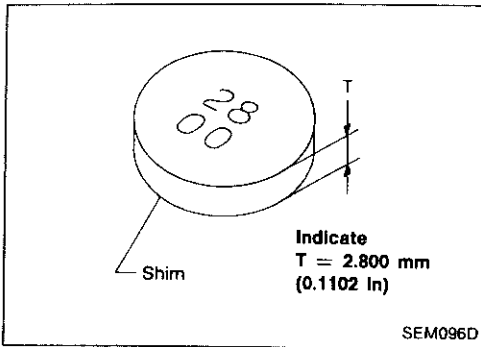

e. Select proper shim.

**Shim thickness (T):  $T_1 \pm 0.025$  mm (0.0010 in)**

- Shims are available in thicknesses from 2.800 mm (0.1102 in) to 3.200 mm (0.1260 in) in steps of 0.025 mm (0.0010 in).

5. Install water outlet.

(1) Before installing water outlet, remove all traces of liquid gasket from mating surface of cylinder head using a scraper.

- Also remove traces of liquid gasket from mating surface of cylinder head.

(2) Apply a continuous bead of liquid gasket to mating surface of water outlet.

- **Use Genuine Liquid Gasket or equivalent.**

6. Install intake manifold.

Refer to "Installation" in "INTAKE MANIFOLD" (EM-36).

# TURBOCHARGER

## Removal

1. Drain coolant from radiator and cylinder block.
2. Remove engine under cover.
3. Remove front exhaust tube.
4. Remove air ducts for turbocharger unit.
5. Remove air cleaner case.
6. Remove wastegate valve control solenoid and its hoses.

GI

MA

**EM**

LC

EC

FE

CL

MT

7. Remove exhaust manifold cover.
8. Remove heat insulator.
9. Remove heated oxygen sensor.
10. Remove EGR tube.

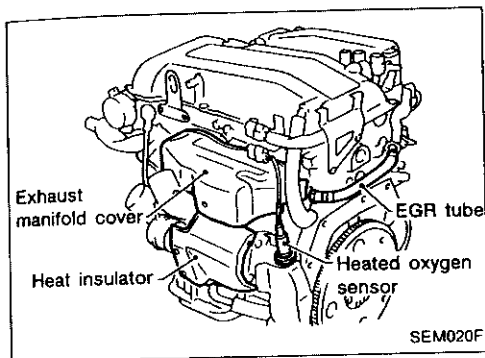

11. Remove connector bolts for water inlet and return tubes and oil inlet tube.

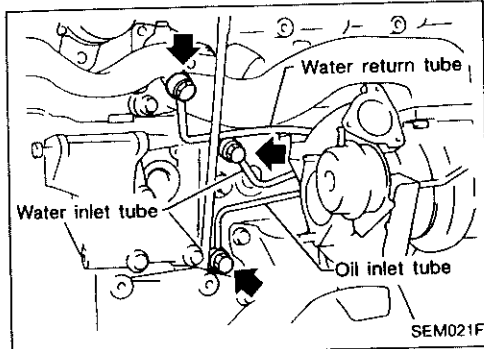

AT

PD

FA

RA

12. Remove oil return hose from cylinder block.

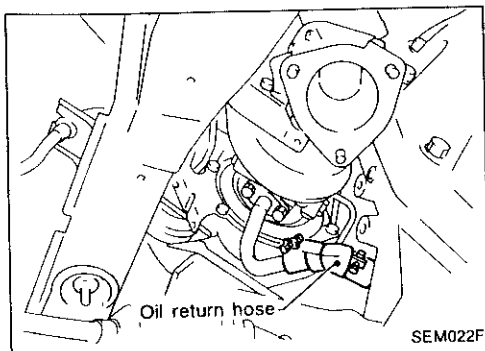

BR

ST

RS

BT

13. Remove exhaust manifold fixing nuts.

HA

EL

IDX

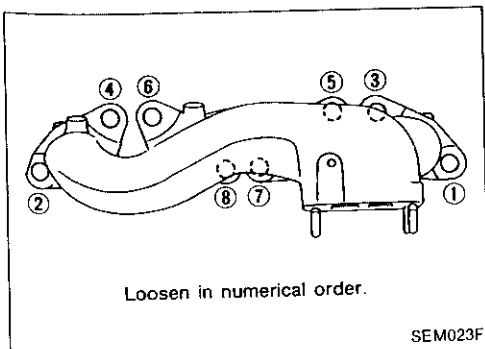

**TURBOCHARGER**

Removal (Cont'd)

# TURBOCHARGER

## Inspection

Perform the following checks. If NG, replace turbocharger unit.

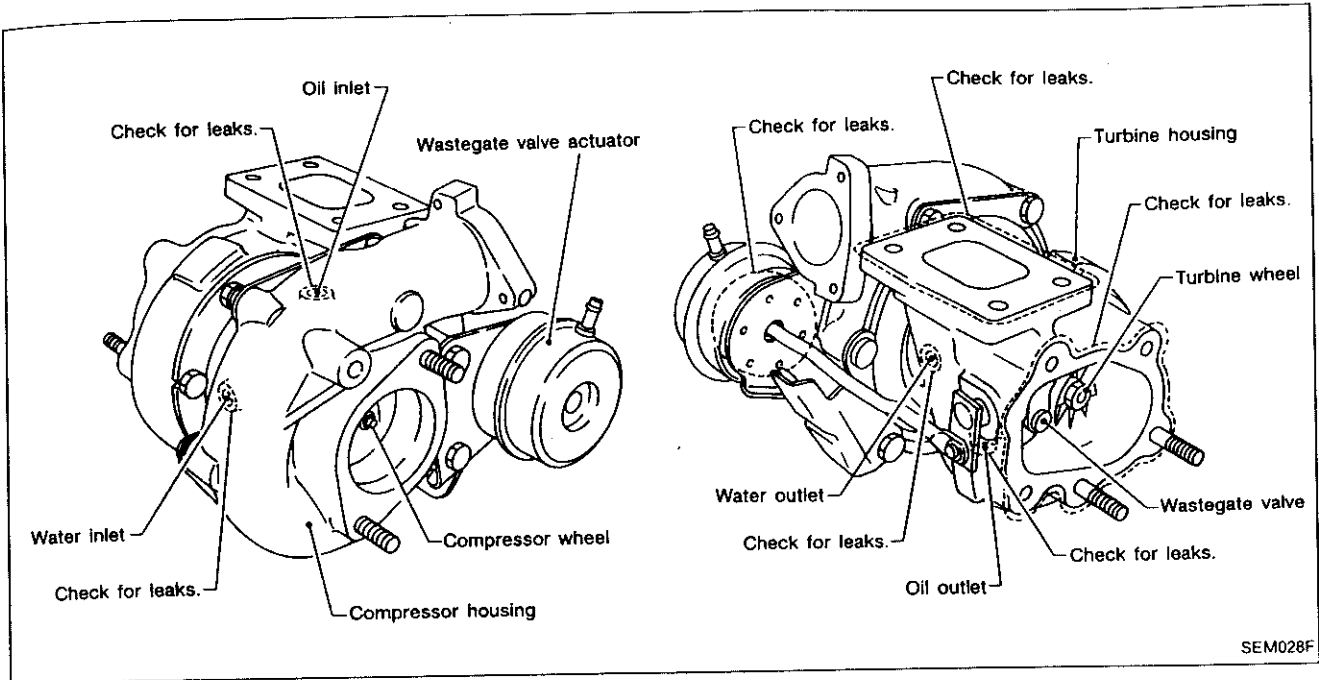

SEM028F

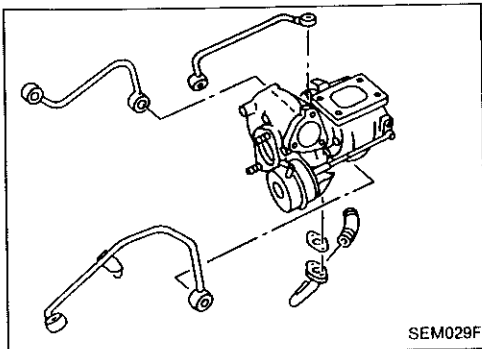

SEM029F

### OIL AND WATER TUBES

Check tubes for clogging.

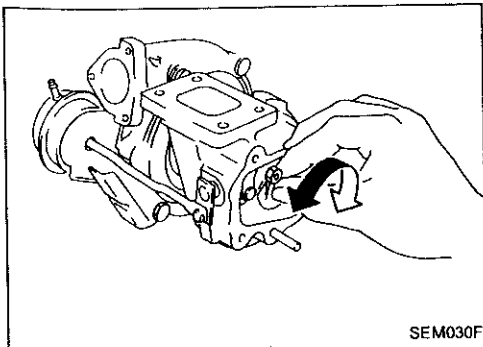

SEM030F

### ROTOR SHAFT

1. Check rotor shaft for smooth rotation.

GI  
MA  
EM  
LC  
EC  
FE  
CL  
MT  
AT  
PD  
FA  
RA  
BR  
ST  
RS  
BT  
HA  
EL  
IDX



## TURBOCHARGER

### Inspection (Cont'd)

2. Check rotor shaft for carbon deposits.

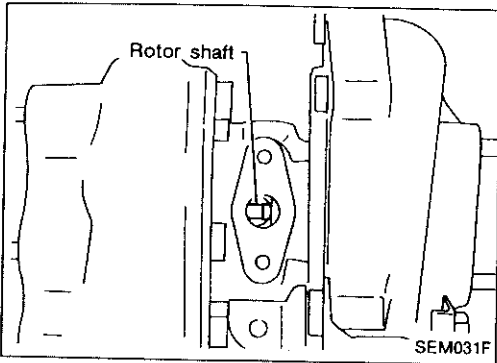

3. Measure rotor shaft runout.

**Runout (Total indicator reading):**

**Standard**

**0.056 - 0.127 mm (0.0022 - 0.0050 in)**

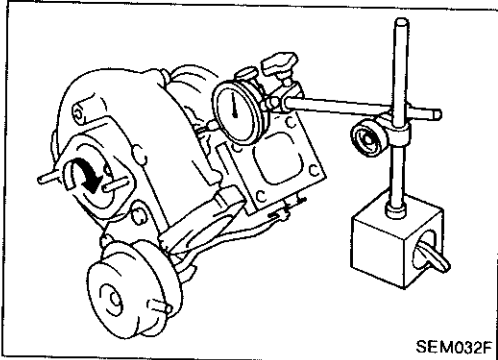

4. Measure rotor shaft end play.

**End play:**



## TURBOCHARGER

### Inspection (Cont'd)

#### WASTEGATE VALVE

Remove rod pin and check wastegate valve for cracks, deformation and smooth movement. Check valve seat surface for smoothness.

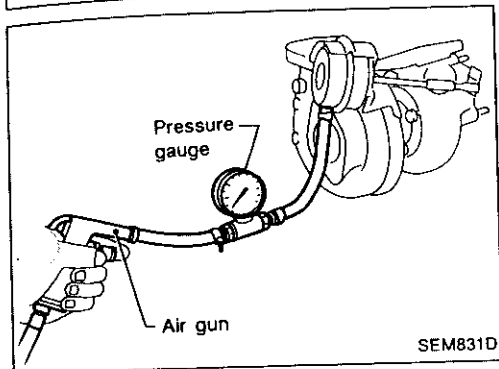
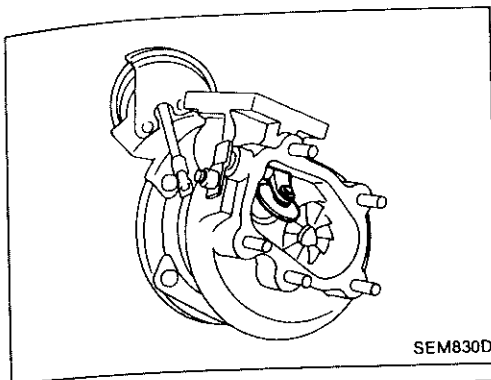

#### WASTEGATE VALVE ACTUATOR

Apply compressed air to wastegate valve actuator and check it for smooth movement.

- Do not applying compressed air to the actuator continuously.
- The air pressure should be in the range of 38.7 to 44.0 kPa (387 to 440 mbar, 290 to 330 mmHg, 11.42 to 12.99 inHg).

#### Assembly

Assembly is the reverse order of disassembly.

- Install gasket between exhaust manifold and turbocharger with lappet side facing exhaust manifold.

- Bend locking plates along the side of turbocharger fastening nuts.

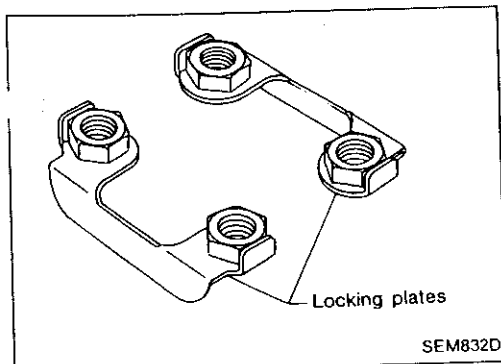

#### Installation

1. Install exhaust manifold fixing nuts.

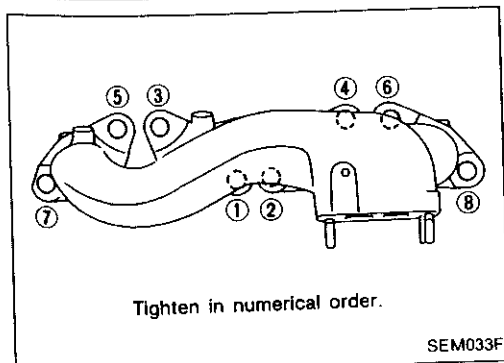

GI

MA

EM

LC

EC

FE

CL

MT

AT

PD

FA

RA

BR

ST

RS

BT

HA

EL

HDX

## TURBOCHARGER

### Installation (Cont'd)

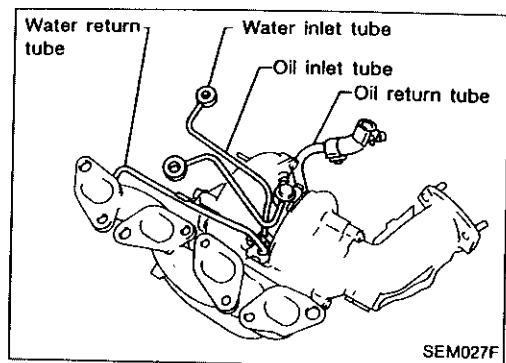

2. Installation is the reverse order of removal.
  - Install oil tubes and water tubes in the following order, aligning the mating marks.
    - a. Oil feed tube
    - b. Water return tube
    - c. Water feed tube
    - d. Oil return tube

# ENGINE REMOVAL

SEC. 112-111

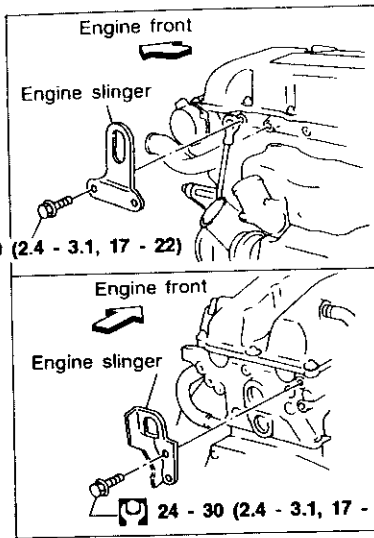

M/T model

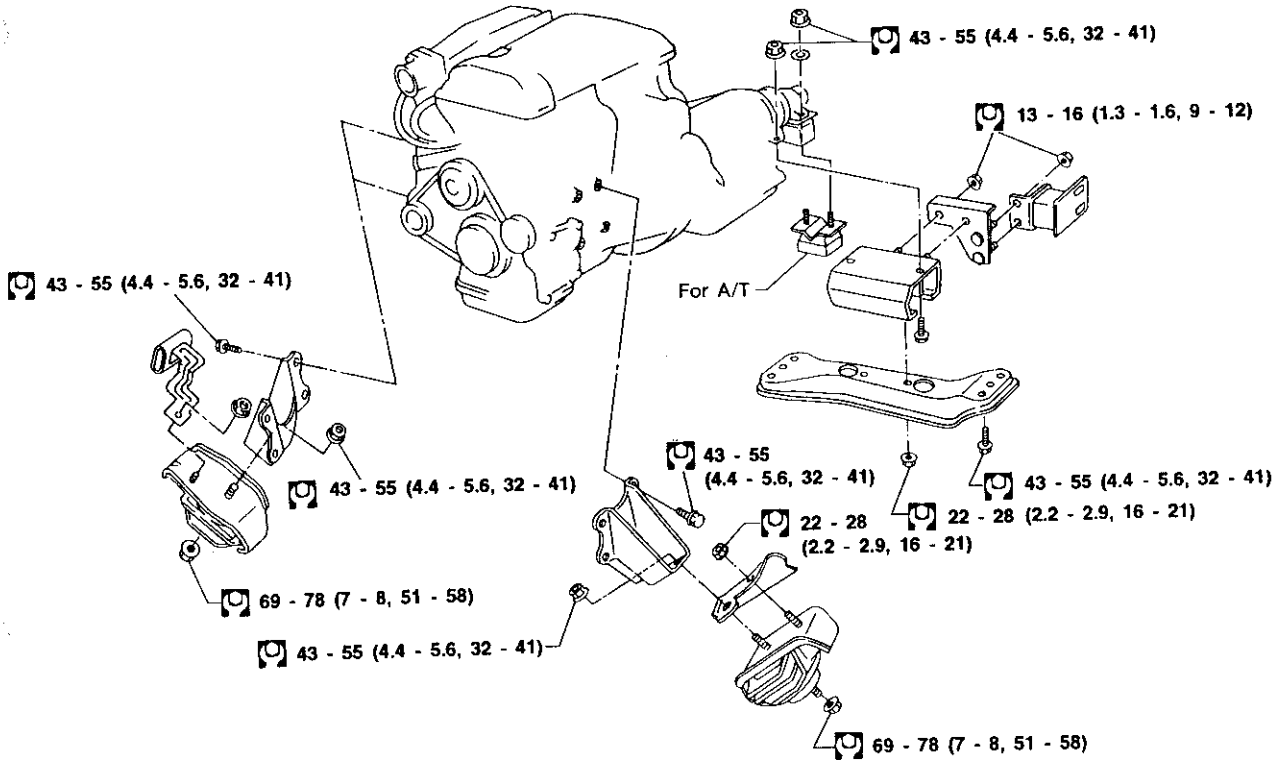
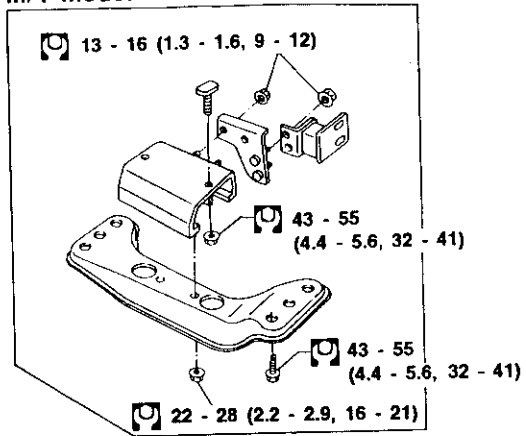

: N·m (kg-m, ft-lb)

GI  
MA  
**EM**  
LC  
EC  
FE  
CL  
MT  
AT  
PD  
FA  
RA  
BR  
ST  
RS  
BT  
HA  
EL  
DX

SEM034F

## ENGINE REMOVAL

### WARNING:

- Situate vehicle on a flat and solid surface.
- Place chocks at front and back of rear wheels.
- Do not remove engine until exhaust system has completely cooled off.

Otherwise, you may burn yourself and/or fire may break out in fuel line.

- For safety during subsequent steps, the tension of wires should be slacked against the engine.
- Before disconnecting fuel hose, release fuel pressure from fuel line.  
Refer to "Releasing Fuel Pressure" in EC section.
- Be sure to hoist engine and transmission in a safe manner.
- For engines not equipped with engine slingers, attach proper slingers and bolts described in PARTS CATALOG.

### CAUTION:

- When lifting engine, be sure to clear surrounding parts. Take special care for accelerator wire casing, brake lines and brake master cylinder.
- In hoisting the engine, always use engine slingers in a safe manner.

### Removal

1. Remove transmission.  
**Refer to AT or MT section.**
2. Remove engine under cover and hood.
3. Drain coolant from both cylinder block drain plug, and radiator drain cock.
4. Drain engine oil from drain plug of oil pan.
5. Remove vacuum hoses, fuel tubes, wires, harness and connectors and so on.
6. Remove front exhaust tubes.
7. Remove radiator and shroud.
8. Remove drive belts.
9. Remove A/C compressor and power steering oil pump from engine.
10. Install engine slingers to cylinder head.
11. Set a suitable hoist on engine slinger.
12. Remove engine mounting bolts from both sides and then slowly raise engine.

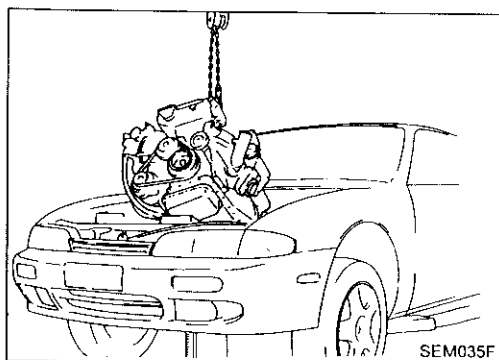

13. Remove engine as shown.

### Installation

Installation is in the reverse order of removal.

# CYLINDER BLOCK

SEC.110-120

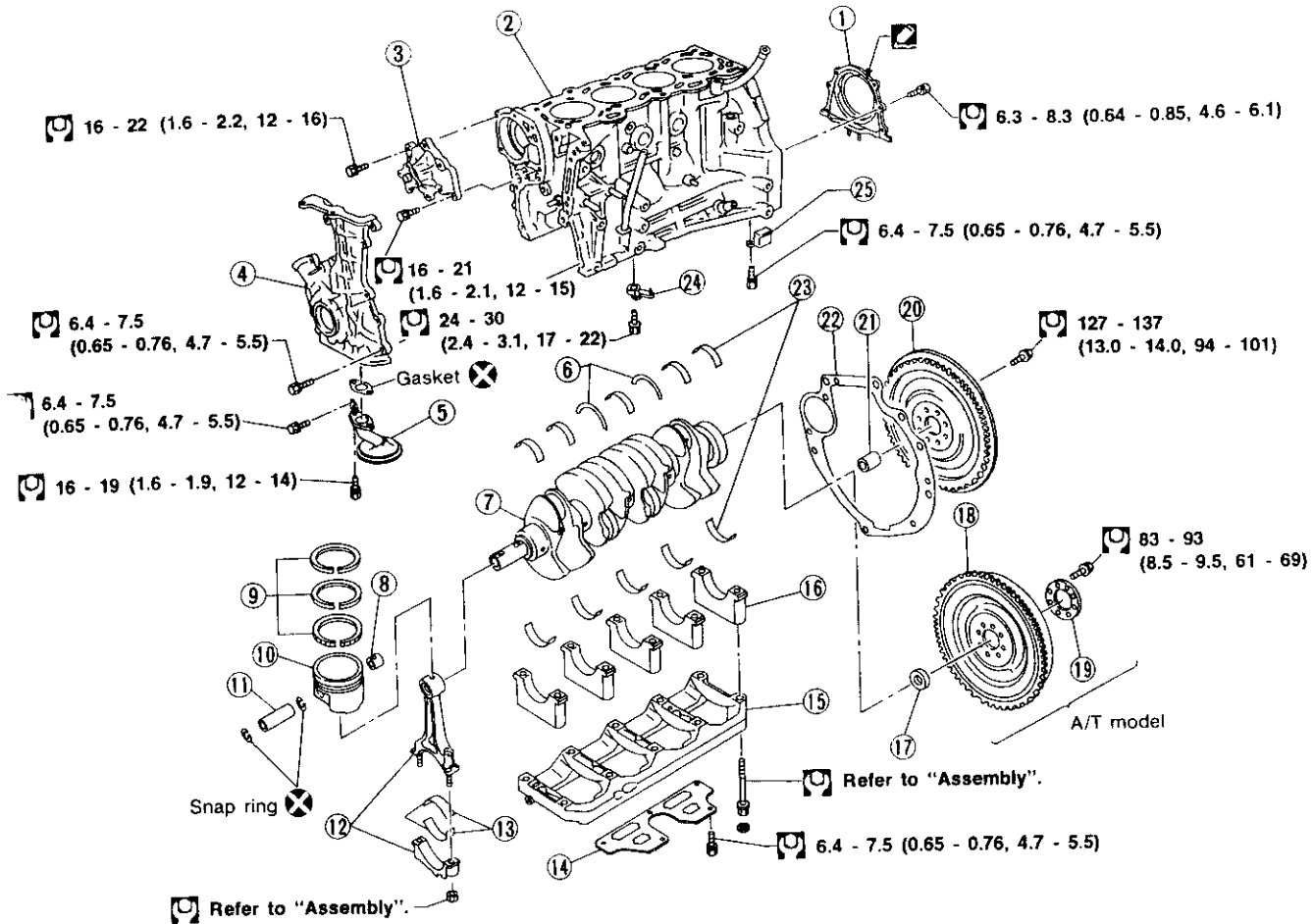

: Apply liquid gasket.  
 : N·m (kg·m, ft·lb)

- ① Rear oil seal retainer
- ② Cylinder block
- ③ Water pump
- ④ Front cover with oil pump
- ⑤ Oil strainer
- ⑥ Thrust bearing
- ⑦ Crankshaft
- ⑧ Connecting rod bushing
- ⑨ Piston rings

- ⑩ Piston
- ⑪ Piston pin
- ⑫ Connecting rod
- ⑬ Connecting rod bearing
- ⑭ Baffle plate
- ⑮ Main bearing beam
- ⑯ Main bearing cap
- ⑰ Pilot converter

- ⑱ Drive plate
- ⑲ Reinforcement plate
- ⑳ Flywheel
- ㉑ Pilot bushing
- ㉒ Rear plate
- ㉓ Main bearing
- ㉔ Oil jet
- ㉕ Baffle plate

GI

MA

**EM**

LC

EC

FE

CL

MT

AT

PD

FA

RA

BR

ST

RS

SEM036F ST

HA

EL

LOX

# CYLINDER BLOCK

- When installing bearings, pistons, or other sliding parts, lubricate contacting surfaces with new engine oil.
- Place removed parts such as bearings and bearing caps in their proper order and direction.
- When installing connecting rod nuts, and main bearing cap bolts, apply new engine oil to threads and seating surfaces.

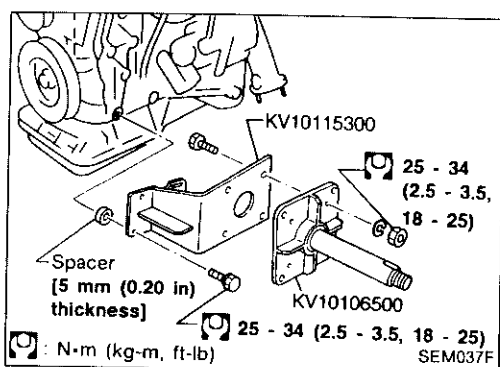

## Disassembly

### PISTON AND CRANKSHAFT

1. Remove engine.  
Refer to "ENGINE REMOVAL" (EM-55).
2. Remove compressor bracket and engine mounting bracket, then install engine on engine stand (ST0501S000).
3. Remove cylinder head.  
Refer to "Removal" in "TIMING CHAIN" (EM-20).
4. Remove oil pan.  
Refer to "Removal" in "OIL PAN" (EM-13).
5. Remove timing chain.  
Refer to "Removal" in "TIMING CHAIN" (EM-20).

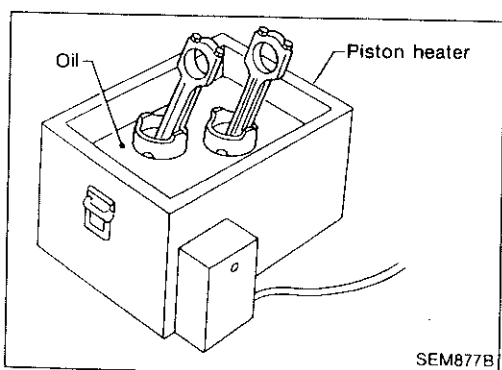

6. Remove pistons with connecting rods.
  - When disassembling piston and connecting rod, remove snap ring first. Then heat piston to 60 to 70°C (140 to 158°F), or use piston pin press stand at room temperature.
7. Remove rear oil seal retainer.

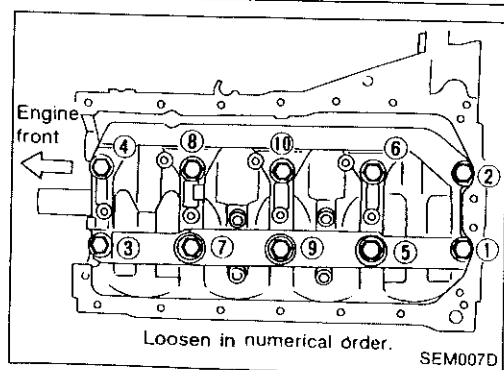

8. Remove bearing beam, bearing cap and crankshaft.
  - Before removing bearing cap, measure crankshaft end play.
  - Bolts should be loosened in two or three steps.

## CYLINDER BLOCK

### Disassembly (Cont'd)

9. Remove baffle plate.
10. Remove oil jets.

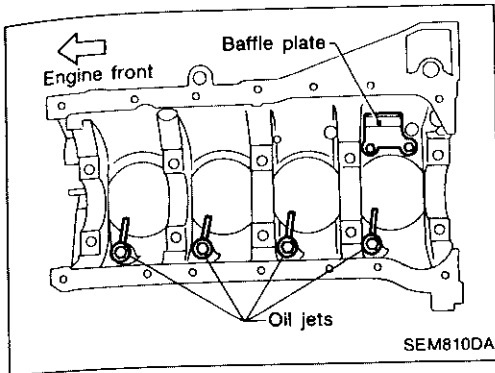

### Inspection

#### PISTON AND PISTON PIN CLEARANCE

1. Measure inner diameter of piston pin hole "dp".  
**Standard diameter "dp":**  
 21.987 - 21.999 mm (0.8656 - 0.8661 in)

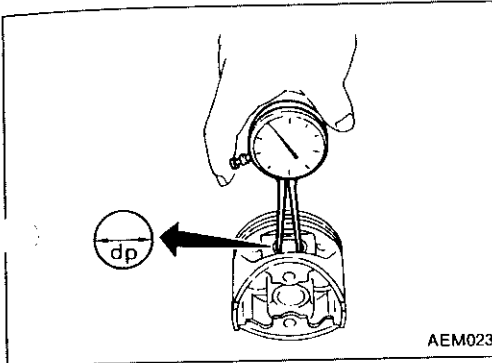

2. Measure outer diameter of piston pin "Dp".  
**Standard diameter "Dp":**  
 21.989 - 22.001 mm (0.8657 - 0.8662 in)

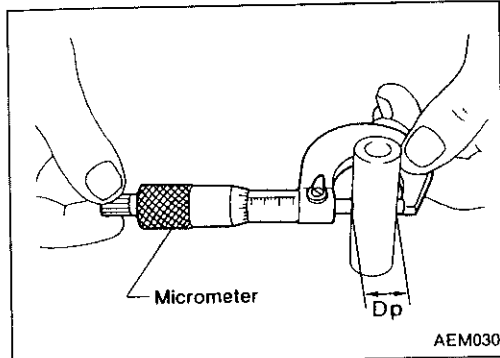

3. Calculate piston pin clearance.  
 $dp - Dp = -0.004 \text{ to } 0 \text{ mm } (-0.0002 \text{ to } 0 \text{ in})$   
 If it exceeds the above value, replace piston assembly with pin.

#### PISTON RING SIDE CLEARANCE

Side clearance:

Top ring

0.045 - 0.080 mm (0.0018 - 0.0031 in)

2nd ring

0.030 - 0.065 mm (0.0012 - 0.0026 in)

Max. limit of side clearance:

0.1 mm (0.004 in)

If out of specification, replace piston and/or piston ring assembly.

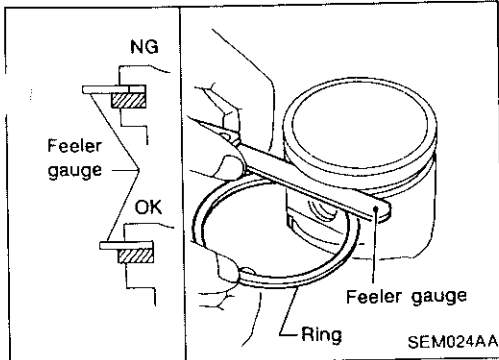

GI

MA

EM

LC

EC

FE

CL

MT

AT

PD

FA

RA

BR

ST

RS

BT

HA

FL

IDX



## CYLINDER BLOCK

### Inspection (Cont'd)

#### PISTON RING END GAP

##### Top ring:

###### Standard

0.20 - 0.30 mm (0.0079 - 0.0118 in)

###### Limit

0.39 mm (0.0154 in)

##### 2nd ring:

###### Standard

0.35 - 0.50 mm (0.0138 - 0.0197 in)

###### Limit

0.59 mm (0.0232 in)

##### Oil ring:

###### Standard

0.20 - 0.60 mm (0.0079 - 0.0236 in)

###### Limit

0.60 mm (0.0272 in)

If out of specification, replace piston ring. If gap exceeds maximum limit with new ring, rebore cylinder and use oversize piston and piston rings.

Refer to SDS (EM-78).

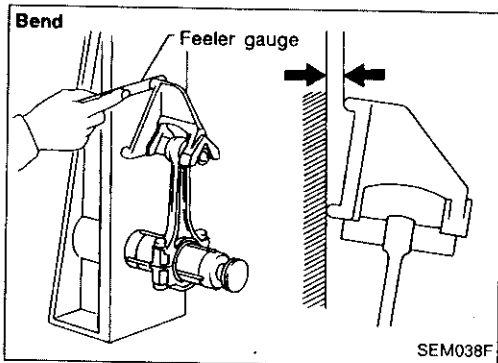
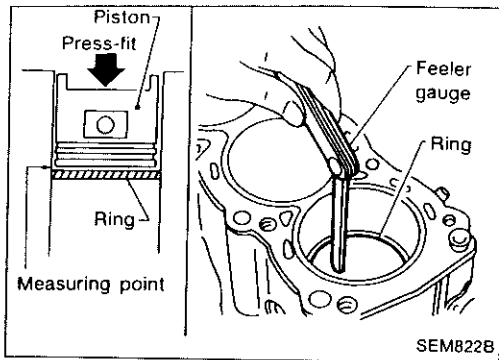

#### CONNECTING ROD BEND AND TORSION

##### Bend:

Limit 0.15 mm (0.0059 in)

per 100 mm (3.94 in) length

##### Torsion:

Limit 0.30 mm (0.0118 in)

per 100 mm (3.94 in) length

If it exceeds the limit, replace connecting rod assembly.

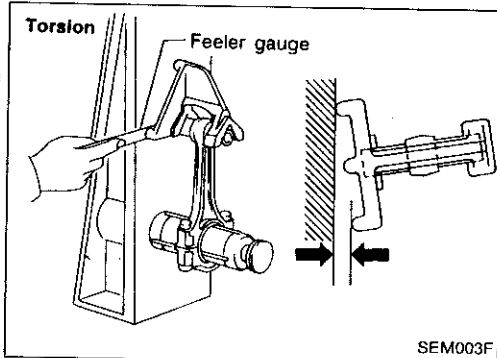

# CYLINDER BLOCK

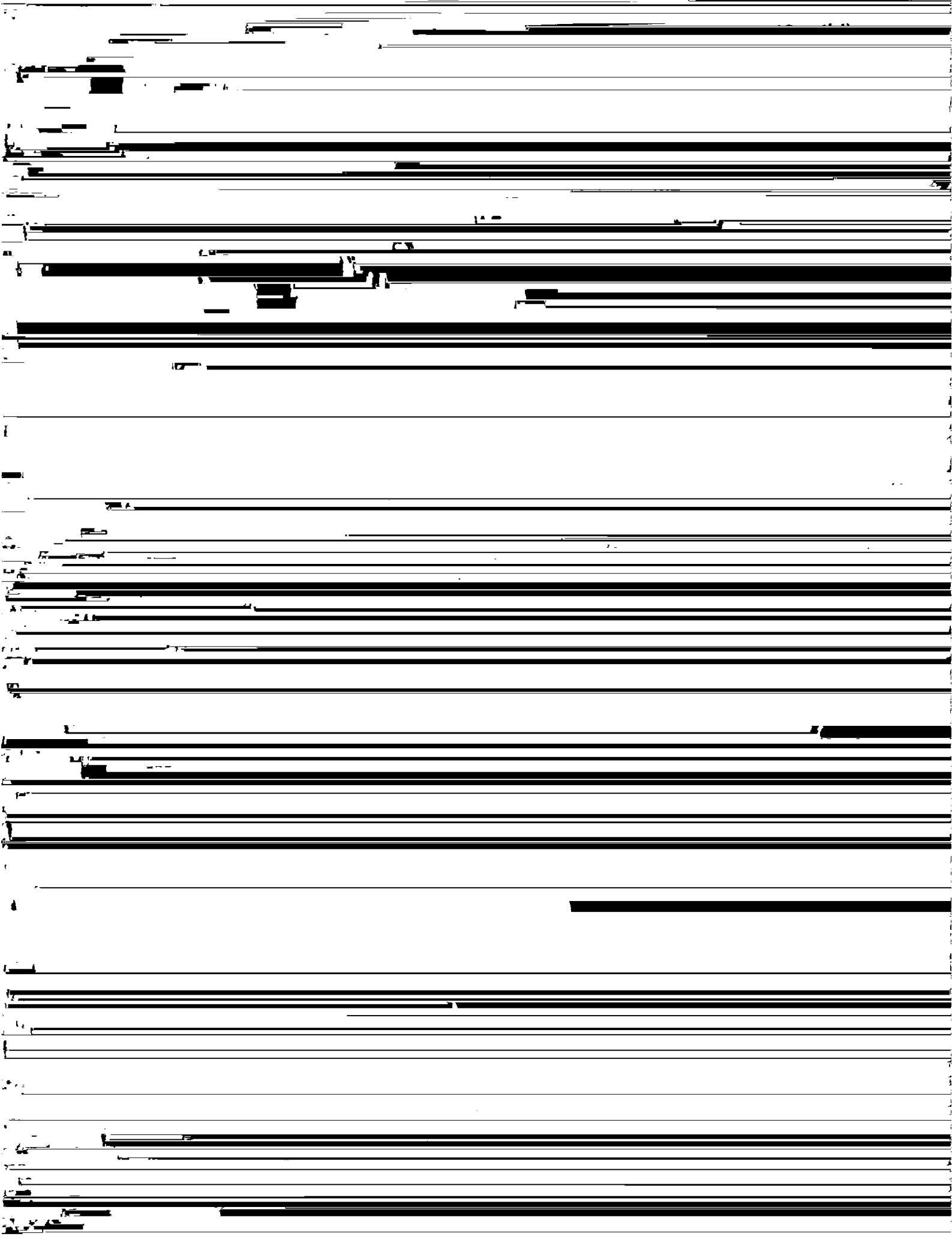

## CYLINDER BLOCK

### Inspection (Cont'd)

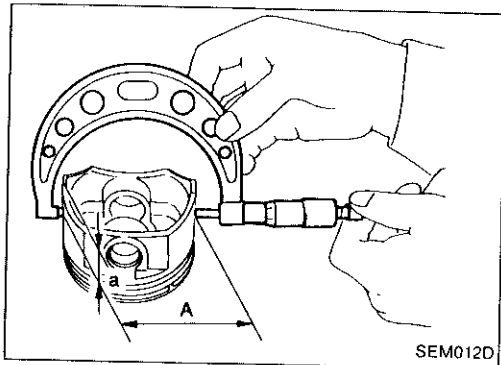
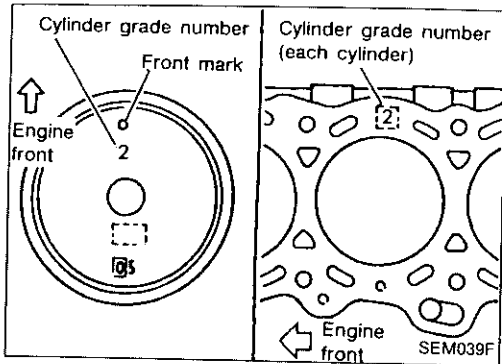

- If cylinder block or piston is replaced, match piston grade with grade number on cylinder block upper surface.

3. Measure piston skirt diameter.

**Piston diameter "A":**

Refer to SDS (EM-78).

**Measuring point "a" (Distance from the bottom):**  
10.5 mm (0.413 in)

4. Check that piston-to-bore clearance is within specification.

**Piston-to-bore clearance "B":**

0.010 - 0.030 mm (0.0004 - 0.0012 in)

5. Determine piston oversize according to amount of cylinder wear.

**Oversize pistons are available for service. Refer to SDS (EM-78).**

6. Cylinder bore size is determined by adding piston-to-bore clearance to piston diameter "A".

**Rebored size calculation:**

$$D = A + B - C$$

where,

**D: Bored diameter**

**A: Piston diameter as measured**

**B: Piston-to-bore clearance**

**C: Honing allowance 0.02 mm (0.0008 in)**

7. Install main bearing caps and tighten bolts to the specified torque. This will prevent distortion of cylinder bores.

8. Cut cylinder bores.

- When any cylinder needs boring, all other cylinders must also be bored.

- Do not cut too much out of cylinder bore at a time. Cut only 0.05 mm (0.0020 in) or so in diameter at a time.

- 9.hone cylinders to obtain specified piston-to-bore clearance.

10. Measure finished cylinder bore for out-of-round and taper.

- Measurement should be done after cylinder bore cools down.

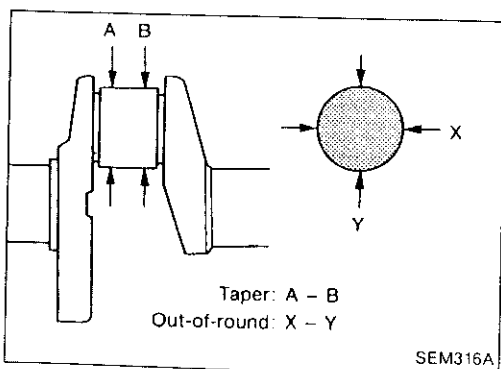

Taper: A - B  
Out-of-round: X - Y

SEM316A

## CRANKSHAFT

1. Check crankshaft main and pin journals for score, wear or cracks.
2. With a micrometer, measure journals for taper and out-of-round.

Unit: mm (in)

Out-of-round (X - Y) and Taper (A - B)	Main journal	Less than 0.005 (0.0002)
	Pin journal	Less than 0.0025 (0.0001)

## CYLINDER BLOCK

### Inspection (Cont'd)

3. Measure crankshaft runout.

**Runout (Total indicator reading):**  
**Less than 0.05 mm (0.0020 in)**

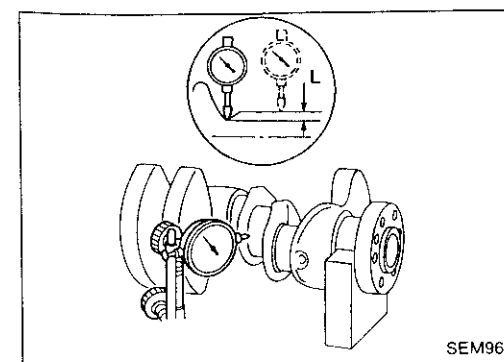
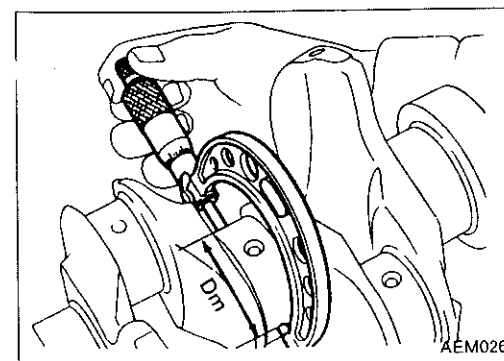
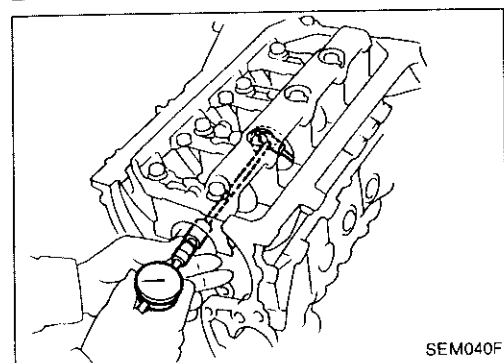
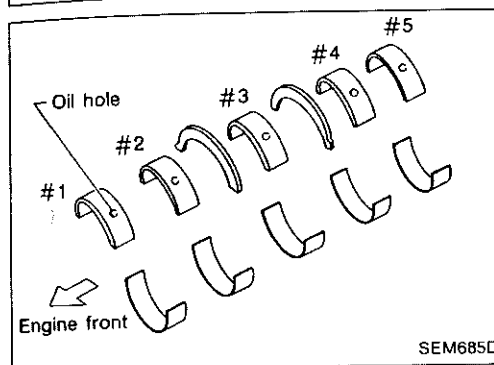
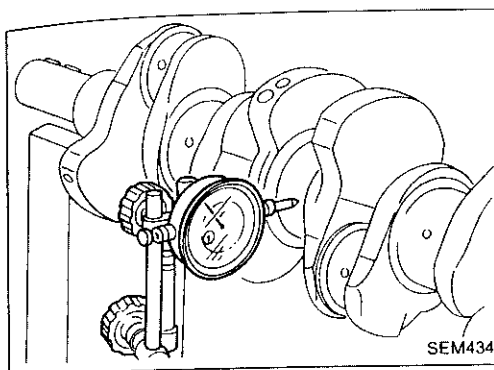

### BEARING CLEARANCE

- Use Method A or Method B. Method A is preferred because it is more accurate.

#### Method A (Using bore gauge & micrometer)

##### Main bearing

1. Set main bearings in their proper positions on cylinder block and main bearing cap.

2. Install main bearing cap and main bearing beam to cylinder block.

**Tighten all bolts in specified procedure. Refer to "CRANKSHAFT" in "Cylinder Block Assembly" (EM-68).**

3. Measure inner diameter "A" of each main bearing.

4. Measure outer diameter "Dm" of each crankshaft main journal.

5. Calculate main bearing clearance.

Main bearing clearance =  $A - D_m$

**Standard: 0.004 - 0.022 mm (0.0002 - 0.0009 in)**

**Limit: 0.050 mm (0.0020 in)**

6. If it exceeds the limit, replace bearing.
7. If clearance cannot be adjusted within the standard of any bearing, grind crankshaft journal and use undersized bearing.

- a. When grinding crankshaft journal, confirm that "L" dimension in fillet roll is more than the specified limit.

**"L": 0.1 mm (0.004 in)**

- b. Refer to SDS for grinding crankshaft and available service parts (EM-80).

GI

MA

EM

LC

EC

FE

CL

MT

AT

PD

FA

RA

BR

ST

RS

BT

HA

EL

IDX

## CYLINDER BLOCK

### Inspection (Cont'd)

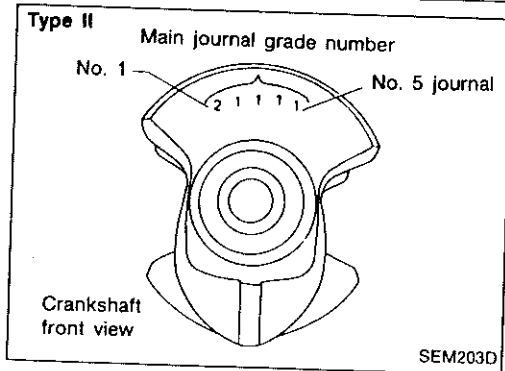
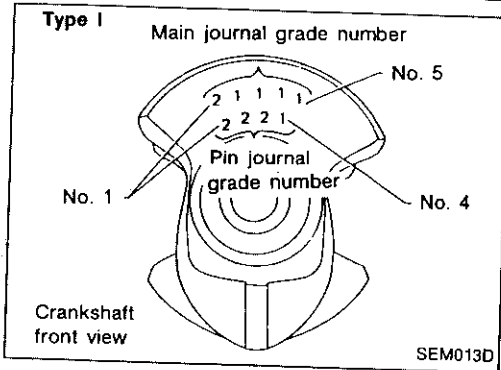
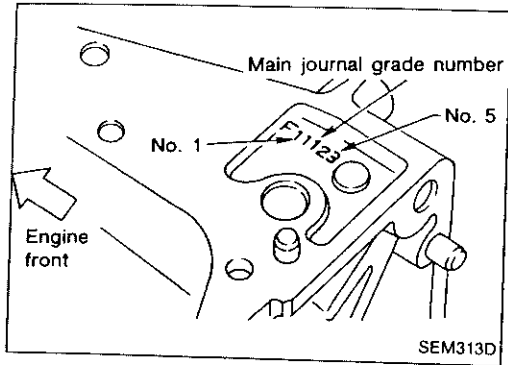

8. If crankshaft is reused, measure main bearing clearances and select thickness of main bearings.

If crankshaft is replaced, select thickness of main bearings as follows:

a. Grade number of each cylinder block main journal is punched on the respective cylinder block. These numbers are punched in either Arabic or Roman numerals.

b. Grade number of each crankshaft main journal is punched on the respective crankshaft. These numbers are punched in either Arabic or Roman numerals.

c. Select main bearing with suitable thickness according to the following table.

### How to select main bearings (Identification mark and color)

Crankshaft journal grade number	Main journal grade number			
	0	1	2	3
0	0 (A, Black)	1 (B, Brown)	2 (C, Green)	3 (D, Yellow)
1	1 (B, Brown)	2 (C, Green)	3 (D, Yellow)	4 (E, Blue)
2	2 (C, Green)	3 (D, Yellow)	4 (E, Blue)	5 (F, Pink)
3	3 (D, Yellow)	4 (E, Blue)	5 (F, Pink)	6 (G, No color)

For example:

Main journal grade number: 1

Crankshaft journal grade number: 2

Main bearing grade number = 1 + 2

= 3 (D, Yellow)

## CYLINDER BLOCK

### Inspection (Cont'd)

#### Connecting rod bearing (Big end)

1. Install connecting rod bearing to connecting rod and cap.
2. Install connecting rod cap to connecting rod.

**Tighten bolts to the specified torque.**

3. Measure inner diameter "C" of each bearing.

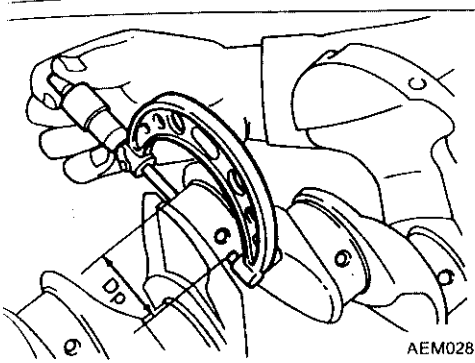
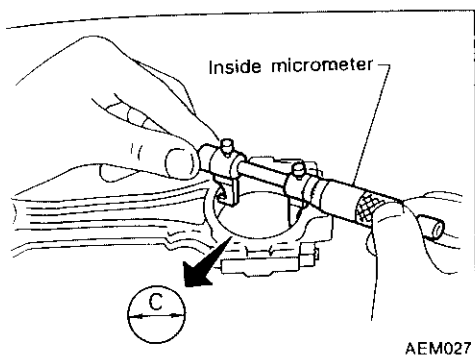

4. Measure outer diameter "Dp" of each crankshaft pin journal.
5. Calculate connecting rod bearing clearance.

**Connecting rod bearing clearance (C - Dp):**

**Standard**

**0.020 - 0.045 mm (0.0008 - 0.0018 in)**

**Limit**

**0.65 mm (0.00256 in)**

6. If it exceeds the limit, replace bearing.
7. If clearance cannot be adjusted within the standard of any bearing, grind crankshaft journal and use undersized bearing.

Refer to step 7 of "BEARING CLEARANCE — Main bearing" (EM-63).

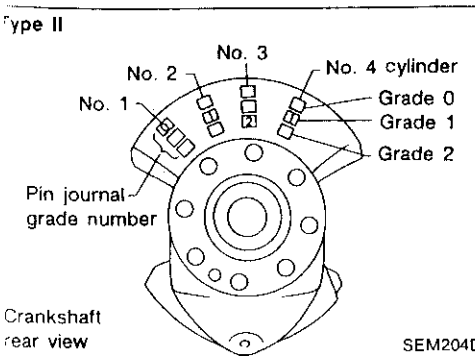
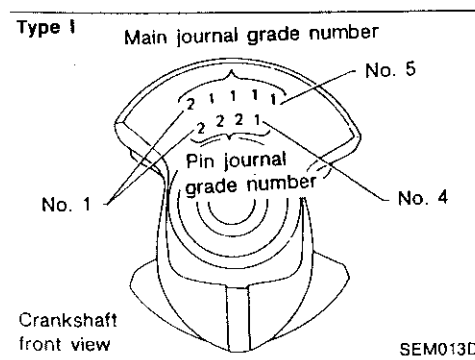

8. If crankshaft is replaced with a new one, select connecting rod bearing according to the following table.

#### Connecting rod bearing grade number:

These numbers are punched in either Arabic or Roman numerals.

Crank pin journal grade number	Connecting rod bearing grade number
0	0
1	1
2	2

#### Identification colors of connecting rod bearing:

**Grade 0; No color**

**Grade 1; Black**

**Grade 2; Brown**

GI

MA

EM

LC

EC

PE

CL

MT

AT

PD

FA

RA

BR

ST

RS

BT

HA

EL

IDX

## CYLINDER BLOCK

### Inspection (Cont'd)

#### Method B (Using plastigage)

##### CAUTION:

- Do not turn crankshaft or connecting rod while plastigage is being inserted.
- When bearing clearance exceeds the specified limit, ensure that the proper bearing has been installed. If clearance cannot be adjusted using any standard bearing grade, grind crankshaft journal and use undersized bearing.

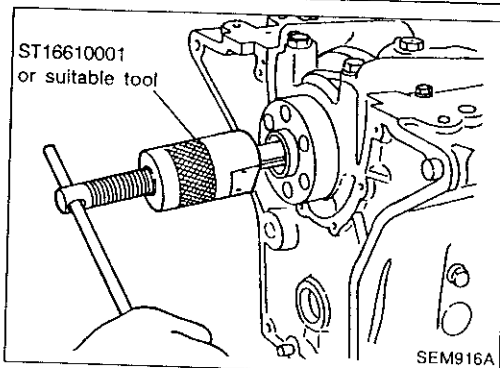
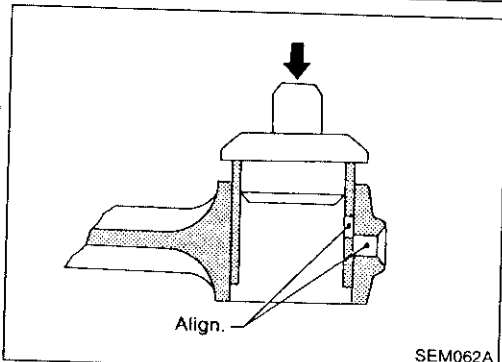
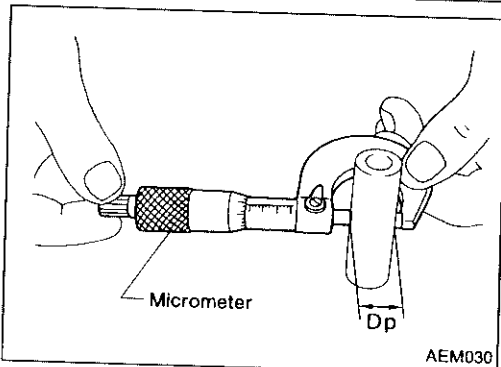
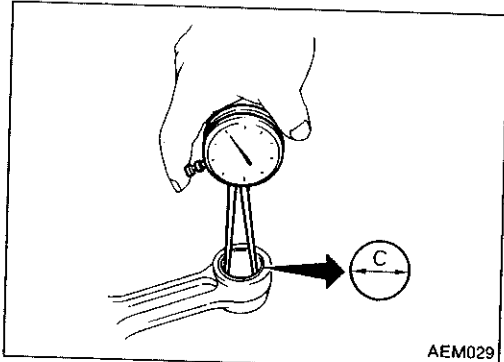
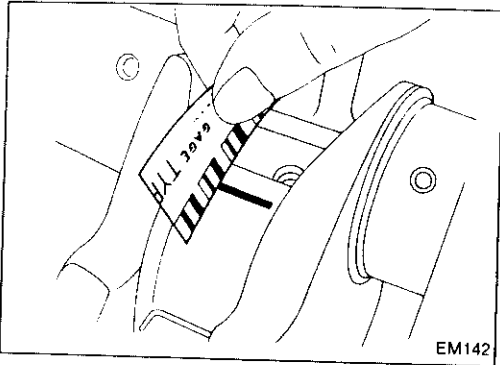

### CONNECTING ROD BUSHING CLEARANCE (Small end)

1. Measure inner diameter "C" of bushing.

2. Measure outer diameter "Dp" of piston pin.
3. Calculate connecting rod bushing clearance.  
Connecting rod bushing clearance = C - Dp

##### Standard:

0.005 - 0.017 mm (0.0002 - 0.0007 in)

##### Limit:

0.023 mm (0.0009 in)

If it exceeds the limit, replace connecting rod assembly or connecting rod bushing and/or piston set with pin.

### REPLACEMENT OF CONNECTING ROD BUSHING (Small end)

1. Drive in small end bushing until it is flush with end surface of rod.

**Be sure to align the oil holes.**

2. Ream the bushing so that clearance with piston pin is within specification.

**Clearance between connecting rod bushing and piston pin:**

0.005 - 0.017 mm (0.0002 - 0.0007 in)

### REPLACEMENT OF PILOT BUSHING (M/T) OR PILOT CONVERTER (A/T)

1. Remove pilot bushing or pilot converter using Tool or suitable tool.

## CYLINDER BLOCK

### Inspection (Cont'd)

2. Install pilot bushing or pilot converter as shown.

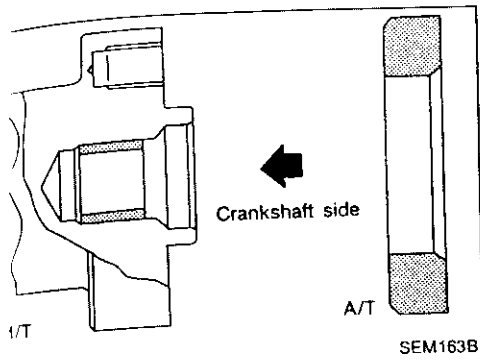

### FLYWHEEL/DRIVE PLATE RUNOUT

Runout (Total indicator reading):

Flywheel (M/T model)

Less than 0.15 mm (0.0059 in)

Drive plate (A/T model)

Less than 0.20 mm (0.0079 in)

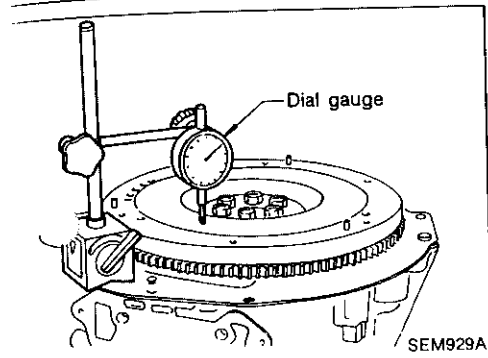

### Assembly

1. Install timing chain oil jet.  
Drive oil jet into cylinder block with punchmark facing up.

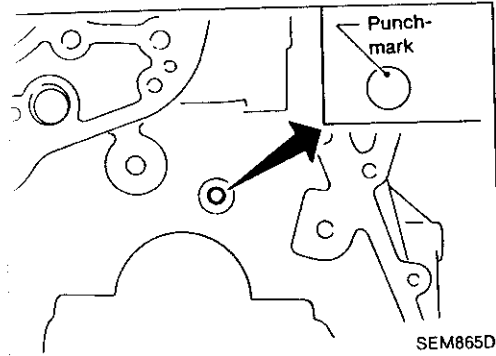

2. Install piston oil jets.
3. Install baffle plate.

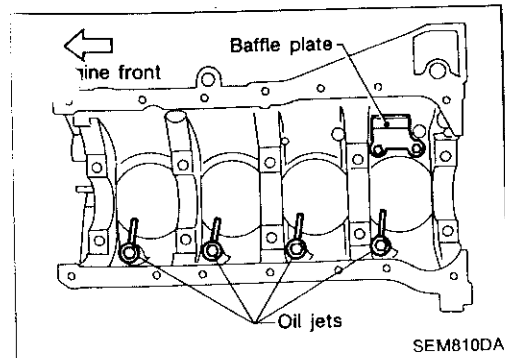

### PISTON

1. Install new snap ring on one side of piston pin hole.

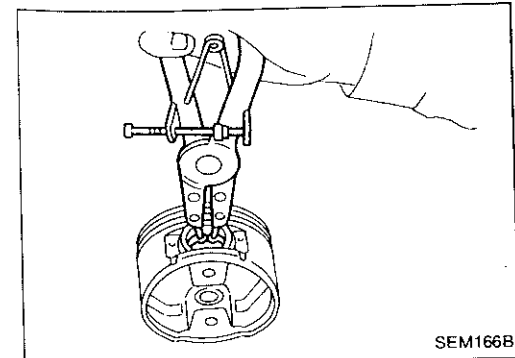

GI

MA

EM

LC

EC

FE

CL

MT

AT

PD

FA

RA

RR

ST

RS

BT

HA

EL

IDX



## CYLINDER BLOCK

### Assembly (Cont'd)

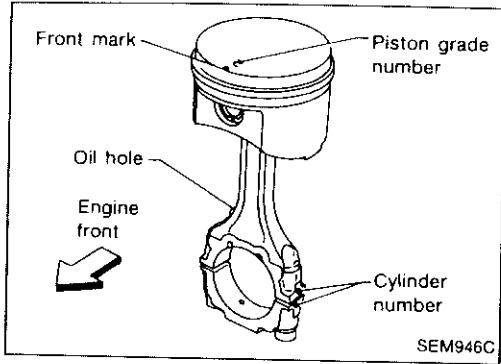

- Heat piston to 60 to 70°C (140 to 158°F) and assemble piston, piston pin, connecting rod and new snap ring.
  - Align the direction of piston and connecting rod.
  - Numbers stamped on connecting rod and cap correspond to each cylinder.
  - After assembly, make sure connecting rod swings smoothly.

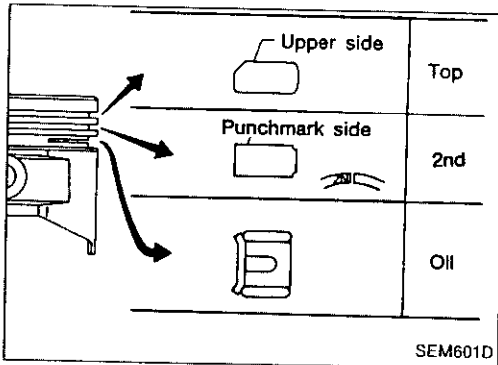

- Set piston rings as shown.

#### CAUTION:

- When piston rings are not replaced, make sure that piston rings are mounted in their original positions.
- When replacing piston rings, if there is no punchmark, install with either side up.

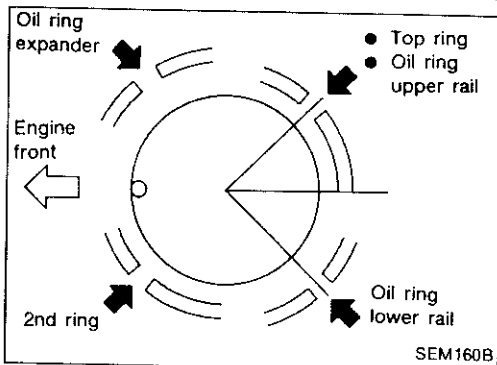

- Locate the ring gap as shown.

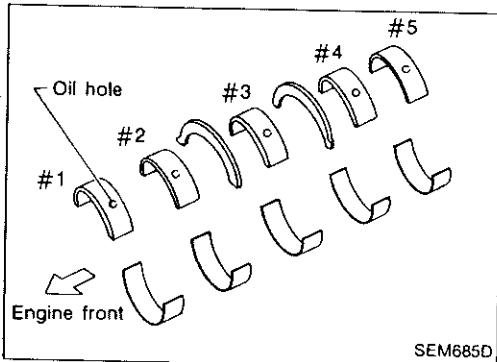

### CRANKSHAFT

- Set main bearings and thrust bearings in their proper positions on cylinder block and main bearing cap.
  - Confirm that correct main bearings are used. Refer to "Inspection" of this section.
  - Direct the oil grooved side of thrust bearing to crankshaft arm side.

## CYLINDER BLOCK

### Assembly (Cont'd)

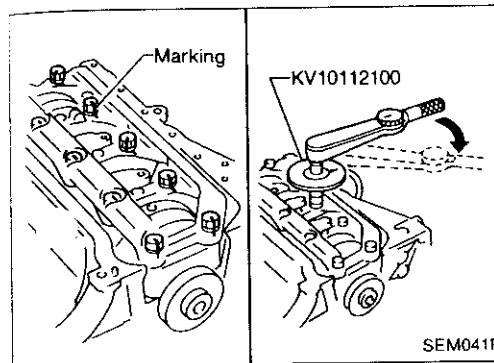
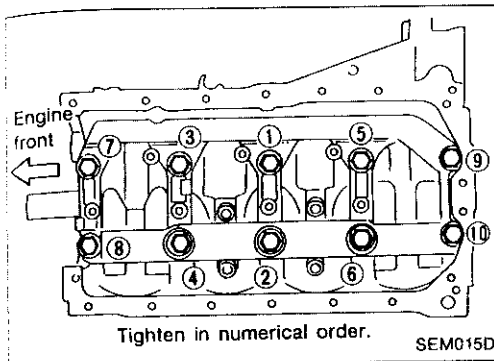

2. Install crankshaft, main bearing caps and beam and tighten bolts to the specified torque.

- Prior to tightening bearing cap bolts, shift crankshaft back and forth to properly seat the bearing cap.

- Tightening procedure

- a. Tighten all bolts to 26 to 32 N·m (2.7 to 3.3 kg-m, 20 to 24 ft-lb).

- b. Turn all bolts 75 to 80 degrees clockwise with Tool or suitable angle wrench.

- c. Loosen all bolts completely.

- d. Tighten all bolts to 32 to 38 N·m (3.3 to 3.9 kg-m, 24 to 28 ft-lb).

- e. Turn all bolts 45 to 50 degrees clockwise with Tool or suitable angle wrench.

- If an angle wrench is not available, mark all bearing cap bolts on the side facing engine rear. Then, turn each bolt specified degrees clockwise. Confirm angle of degrees with a graduator, not by eye-measurement.

- After securing bearing cap bolts, make sure crankshaft turns smoothly by hand.

3. Measure crankshaft end play.

GI

MA

EM

LC

EC

FE

CL

MT

## CYLINDER BLOCK

### Assembly (Cont'd)

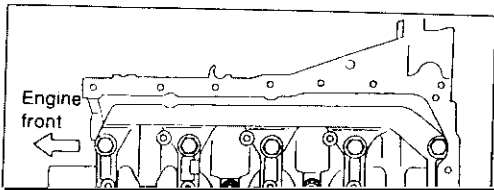

- b. Install connecting rod bearing caps.  
Tighten connecting rod bearing cap nuts in the following two steps.

#### Step 1

Tighten nuts to 14 to 16 N·m (1.4 to 1.6 kg-m, 10 to 12 ft-lb)

## CYLINDER BLOCK

### Assembly (Cont'd)

- (3) Apply a continuous bead of liquid gasket to mating surface of rear oil seal retainer.
- Use Genuine Liquid Gasket or equivalent.

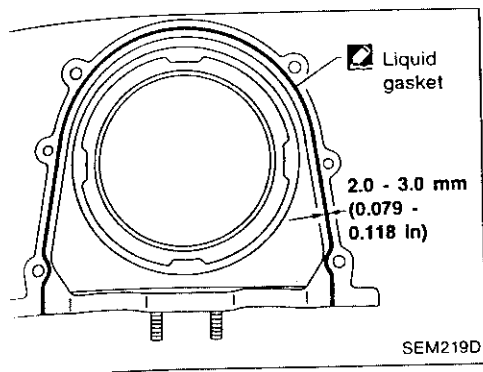

GI

MA

**EM**

LC

EC

FE

CL

MT

AY

PD

FA

RA

BR

ST

RS

BT

HA

EL

IDX

## SERVICE DATA AND SPECIFICATIONS (SDS)

### General Specifications

Cylinder arrangement		In-line 4
Displacement	cm <sup>3</sup> (cu in)	1,998 (121.92)
Bore and stroke	mm (in)	86 x 86 (3.39 x 3.39)
Valve arrangement		DOHC
Firing order		1-3-4-2
Number of piston rings		
Compression		2
Oil		1
Number of main bearings		5
Compression ratio		8.5

### COMPRESSION PRESSURE

	Unit: kPa (bar, kg/cm <sup>2</sup> , psi)/300 rpm
Standard	1,079 (10.79, 11.0, 156)
Minimum	883 (8.83, 9.0, 128)
Differential limit between cylinders	98 (0.98, 1.0, 14)

# SERVICE DATA AND SPECIFICATIONS (SDS)

## Inspection and Adjustment

### CYLINDER HEAD

	Unit: mm (in)	
	Standard	Limit
Head surface distortion	Less than 0.03 (0.0012)	0.1 (0.004)

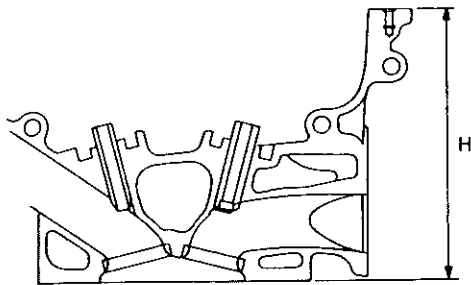

SEM043F

Nominal cylinder head height "H"	136.9 - 137.1 (5.390 - 5.398)
Resurfacing limit	0.2 (0.008)*

\* Sum of resurfacing cylinder head and cylinder block

### VALVE

Unit: mm (in)

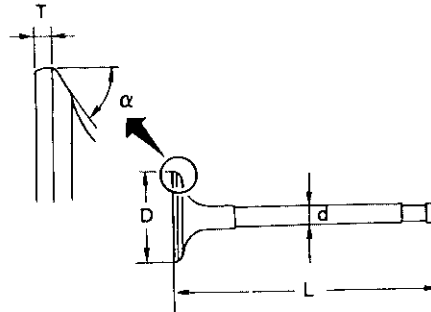

SEM188-B

#### Valve head diameter "D"

Intake	34.0 - 34.2 (1.339 - 1.346)
Exhaust	30.0 - 30.2 (1.181 - 1.189)

#### Valve length "L"

Intake	101.19 - 101.61 (3.9839 - 4.0004)
Exhaust	102.11 - 102.53 (4.0201 - 4.0366)

#### Valve stem diameter "d"

Intake	5.965 - 5.980 (0.2348 - 0.2354)
Exhaust	6.945 - 6.960 (0.2734 - 0.2740)

#### Valve seat angle " $\alpha$ "

Intake	45°15' - 45°45'
Exhaust	

#### Valve margin "T"

Intake	1.1 (0.043)
Exhaust	1.3 (0.051)

#### Valve margin "T" limit

More than 0.5 (0.020)

#### Valve stem end surface grinding limit

Less than 0.2 (0.008)

GI

MA

**EM**

LC

EC

FE

CL

MT

AT

PD

FA

RA

BR

ST

RS

BT

HA

EL

IDX

## SERVICE DATA AND SPECIFICATIONS (SDS)

### Inspection and Adjustment (Cont'd)

#### Valve spring

Free height	mm (in)	49.36 (1.9433)
Pressure	N (kg, lb) at height mm (in)	
Standard		578.02 - 641.57 (58.94 - 65.42, 129.96 - 144.25) at 30.0 (1.181)
Limit		549.2 (56.0, 123.5) at 30.0 (1.181)
Out-of-square	mm (in)	Less than 2.2 (0.087)

#### Hydraulic lash adjuster (HLA)

Unit: mm (in)

HLA outer diameter	16.980 - 16.993 (0.6685 - 0.6690)
HLA guide inner diameter	17.000 - 17.020 (0.6693 - 0.6701)
Clearance between HLA and HLA guide	0.007 - 0.040 (0.0003 - 0.0016)

#### Valve guide

Unit: mm (in)

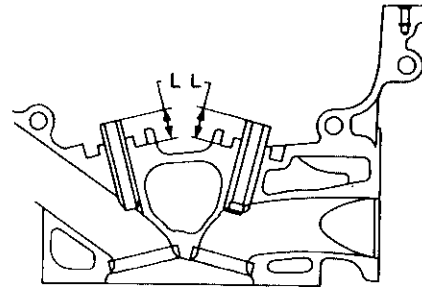

SEM083D

		Standard	Service
Valve guide			
Outer diameter	Intake	10.023 - 10.034 (0.3946 - 0.3950)	10.223 - 10.234 (0.4025 - 0.4029)
	Exhaust	11.023 - 11.034 (0.4340 - 0.4344)	11.223 - 11.234 (0.4418 - 0.4423)
Valve guide			
Inner diameter (Finished size)	Intake	6.000 - 6.018 (0.2362 - 0.2369)	
	Exhaust	7.000 - 7.018 (0.2756 - 0.2763)	
Cylinder head valve guide hole diameter	Intake	9.975 - 9.996 (0.3927 - 0.3935)	10.175 - 10.196 (0.4006 - 0.4014)
	Exhaust	10.975 - 10.996 (0.4321 - 0.4329)	11.175 - 11.196 (0.4400 - 0.4408)
Interference fit of valve guide		0.027 - 0.059 (0.0011 - 0.0023)	
		Standard	Limit
Stem to guide clearance	Intake	0.020 - 0.053 (0.0008 - 0.0021)	0.08 (0.0031)
	Exhaust	0.040 - 0.073 (0.0016 - 0.0029)	0.1 (0.004)
Valve deflection limit		0.2 (0.008)	
Projection length "L"		14.0 - 14.2 (0.551 - 0.559)	

# SERVICE DATA AND SPECIFICATIONS (SDS)

## Inspection and Adjustment (Cont'd)

### Valve seat

Unit: mm (in)

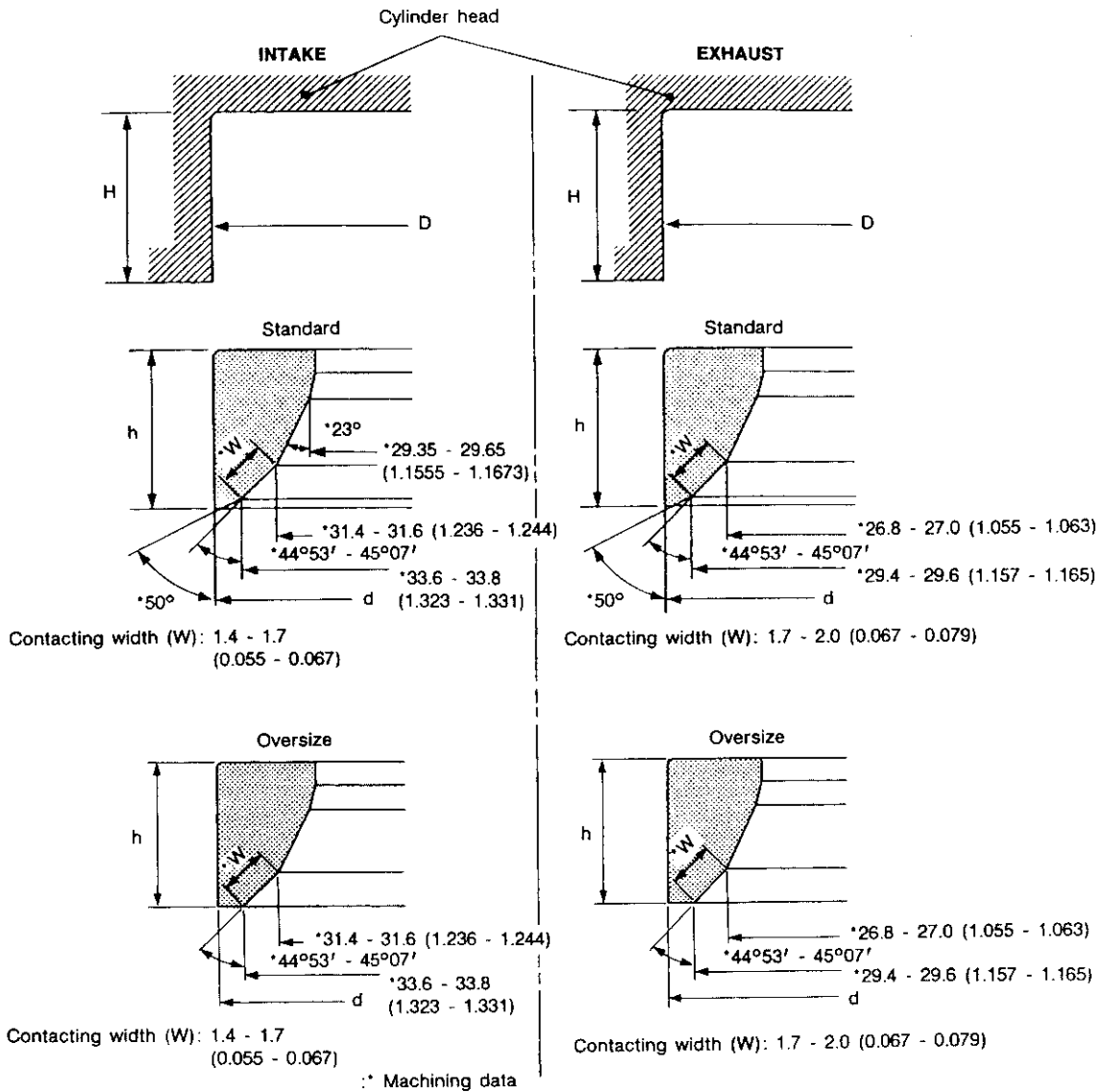

SEM651D

		Standard	Service
Cylinder head seat recess diameter (D)	In.	35.000 - 35.016 (1.3780 - 1.3786)	35.500 - 35.516 (1.3976 - 1.3983)
	Ex.	31.000 - 31.016 (1.2205 - 1.2211)	31.500 - 31.516 (1.2402 - 1.2408)
Valve seat interference fit	In.	0.064 - 0.096 (0.0025 - 0.0038)	
	Ex.	0.064 - 0.096 (0.0025 - 0.0038)	
Valve seat outer diameter (d)	In.	35.080 - 35.096 (1.3811 - 1.3817)	35.580 - 35.596 (1.4008 - 1.4014)
	Ex.	31.080 - 31.096 (1.2236 - 1.2242)	31.580 - 31.596 (1.2433 - 1.2439)
Depth (H)	In.	6.25 (0.2461)	
	Ex.	6.25 (0.2461)	
Height (h)		6.2 - 6.3 (0.244 - 0.248)	5.4 - 5.5 (0.213 - 0.217)

GI  
 MA  
**EM**  
 LC  
 EC  
 FE  
 CL  
 MT  
 AT  
 PD  
 FA  
 RA  
 BR  
 ST  
 RS  
 BT  
 HA  
 EL  
 IDX



# SERVICE DATA AND SPECIFICATIONS (SDS)

## Inspection and Adjustment (Cont'd)

### Valve shim clearance adjustment

Unit: mm (in)

Valve shim clearance (Cold)	Less than 0.025 (0.001)
Shim thickness "T"	$T_1 \pm 0.025$ (0.001)

### Available shims

Thickness mm (in)	Identification mark
2.800 (0.1102)	28 00
2.825 (0.1112)	28 25
2.850 (0.1122)	28 50
2.875 (0.1132)	28 75
2.900 (0.1142)	29 00
2.925 (0.1152)	29 25
2.950 (0.1161)	29 50
2.975 (0.1171)	29 75
3.000 (0.1181)	30 00
3.025 (0.1191)	30 25
3.050 (0.1201)	30 50
3.075 (0.1211)	30 75
3.100 (0.1220)	31 00
3.125 (0.1230)	31 25
3.150 (0.1240)	31 50
3.175 (0.1250)	31 75
3.200 (0.1260)	32 00

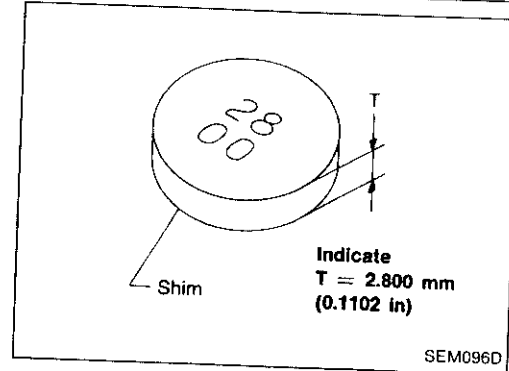
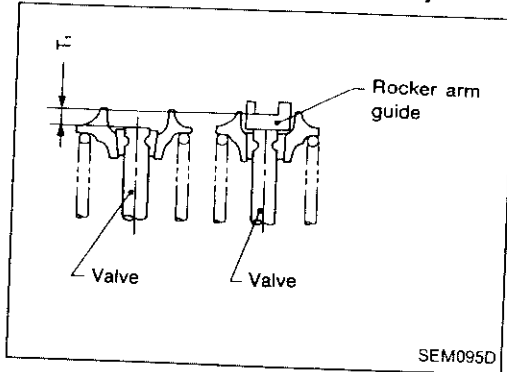

# SERVICE DATA AND SPECIFICATIONS (SDS)

## Inspection and Adjustment (Cont'd)

### CAMSHAFT AND CAMSHAFT BEARING

Unit: mm (in)

	Standard	Limit
Camshaft journal to bearing clearance	0.045 - 0.086 (0.0018 - 0.0034)	0.15 (0.0059)
Inner diameter of camshaft bearing	28.000 - 28.021 (1.1024 - 1.1032)	—
Outer diameter of camshaft journal	27.935 - 27.955 (1.0998 - 1.1006)	—
Camshaft runout [TIR*]	Less than 0.02 (0.0008)	0.1 (0.004)
Camshaft sprocket runout [TIR*]	Less than 0.25 (0.0098)	—
Camshaft end play	0.092 - 0.173 (0.0036 - 0.0068)	0.20 (0.0079)

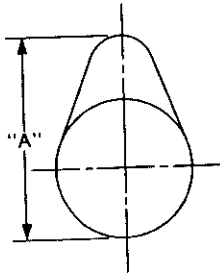

EM671

#### Cam height "A"

Intake	37.920 - 38.110 (1.4929 - 1.5004)
Exhaust	37.920 - 38.110 (1.4929 - 1.5004)

#### Wear limit of cam height

0.2 (0.008)

#### Valve lift

Intake	9.2 (0.362)
Exhaust	9.2 (0.362)

\*Total indicator reading

Valve timing (VTC solenoid valve OFF)

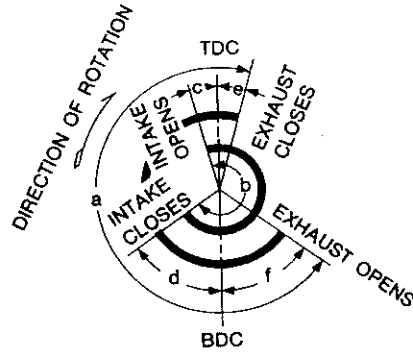

EM120

Unit: degree

a	b	c	d	e	f
240°	240°	-6°	66°	7°	53°

GI

MA

EM

LC

EC

FE

CL

MT

AT

PD

FA

RA

BR

ST

RS

BT

HA

EL

IDX

## SERVICE DATA AND SPECIFICATIONS (SDS)

### Inspection and Adjustment (Cont'd)

#### CYLINDER BLOCK

Unit: mm (in)

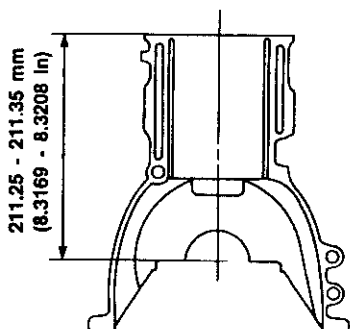

SEM008D

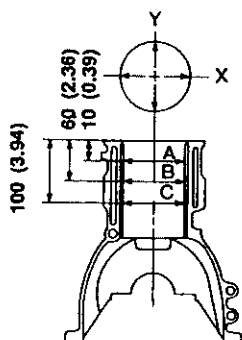

SEM686D

#### Surface flatness

Standard	Less than 0.03 (0.0012)
Limit	0.10 (0.0039)

#### Cylinder bore

##### Inner diameter

##### Standard

Grade No. 1	86.000 - 86.010 (3.3858 - 3.3862)
Grade No. 2	86.010 - 86.020 (3.3862 - 3.3866)
Grade No. 3	86.020 - 86.030 (3.3866 - 3.3870)

Wear limit 0.20 (0.0079)

Out-of-round (X - Y) Less than 0.015 (0.0006)

Taper (A - B and A - C) Less than 0.010 (0.0004)

#### Difference in inner diameter between cylinders

Limit Less than 0.05 (0.0020)

#### Main journal inner diameter

Grade No. 0	58.944 - 58.950 (2.3206 - 2.3209)
Grade No. 1	58.950 - 58.956 (2.3209 - 2.3211)
Grade No. 2	58.956 - 58.962 (2.3211 - 2.3213)
Grade No. 3	58.962 - 58.968 (2.3213 - 2.3216)

#### PISTON, PISTON RING AND PISTON PIN

#### Available piston

Unit: mm (in)

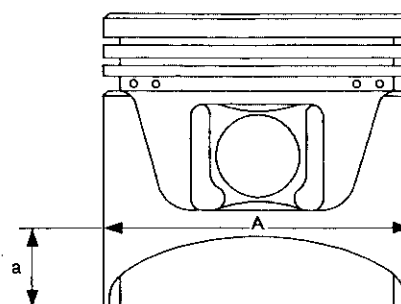

SEM750C

#### Piston skirt diameter "A"

##### Standard

Grade No. 1	85.980 - 85.990 (3.3850 - 3.3854)
Grade No. 2	85.990 - 86.000 (3.3854 - 3.3858)
Grade No. 3	86.000 - 86.010 (3.3858 - 3.3862)
0.20 (0.0079) over-size (Service)	86.180 - 86.210 (3.3929 - 3.3941)

"a" dimension 10.5 (0.413)

Piston clearance to cylinder block 0.010 - 0.030 (0.0004 - 0.0012)

Piston pin hole diameter 21.987 - 21.999 (0.8656 - 0.8661)

# SERVICE DATA AND SPECIFICATIONS (SDS)

## Inspection and Adjustment (Cont'd)

### CONNECTING ROD

#### Piston ring

Unit: mm (in)

Side clearance		
Top		
Standard	0.045 - 0.080 (0.0018 - 0.0031)	
Limit	0.1 (0.004)	
2nd		
Standard	0.030 - 0.065 (0.0012 - 0.0026)	
Limit	0.1 (0.004)	
End gap		
Top		
Standard	0.20 - 0.30 (0.0079 - 0.0118)	
Limit	0.39 (0.0154)	
2nd		
Standard	0.35 - 0.50 (0.0138 - 0.0197)	
Limit	0.59 (0.0232)	
Oil		
Standard	0.20 - 0.60 (0.0079 - 0.0236)	
Limit	0.69 (0.0272)	

Unit: mm (in)

Center distance	136.30 (5.3661)	GI
Bend [per 100 (3.94)]		
Limit	0.15 (0.0059)	MA
Torsion [per 100 (3.94)]		
Limit	0.3 (0.0012)	EM
Connecting rod small end inner diameter	24.980 - 25.000 (0.9835 - 0.9843)	LC
Piston pin bushing inner diameter*	22.000 - 22.012 (0.8661 - 0.8666)	EC
Connecting rod big end inner diameter	51.000 - 51.013 (2.0079 - 2.0084)	FE
Side clearance		
Standard	0.20 - 0.35 (0.0079 - 0.0138)	FE
Limit	0.5 (0.020)	

\*After installing in connecting rod

#### Piston pin

Unit: mm (in)

Piston pin outer diameter	21.989 - 22.001 (0.8657 - 0.8662)
Interference fit of piston pin to piston	0 - 0.004 (0 - 0.0002)
Piston pin to connecting rod bushing clearance	
Standard	0.005 - 0.017 (0.0002 - 0.0007)
Limit	0.023 (0.0009)

\* Values measured at ambient temperature of 20°C (68°F)

GI

MA

EM

LC

EC

FE

CL

MT

AT

PD

FA

RA

BR

ST

RS

BT

HA

EL

IDX

# SERVICE DATA AND SPECIFICATIONS (SDS)

## Inspection and Adjustment (Cont'd)

### CRANKSHAFT

Unit: mm (in)

Main journal dia. "Dm"	
Grade No. 0	54.974 - 54.980 (2.1643 - 2.1646)
Grade No. 1	54.968 - 54.974 (2.1641 - 2.1643)
Grade No. 2	54.962 - 54.968 (2.1639 - 2.1641)
Grade No. 3	54.956 - 54.962 (2.1636 - 2.1639)
Pin journal dia. "Dp"	
Grade No. 0	47.968 - 47.974 (1.8885 - 1.8887)
Grade No. 1	47.962 - 47.968 (1.8883 - 1.8885)
Grade No. 2	47.956 - 47.962 (1.8880 - 1.8883)
Center distance "r"	
	42.96 - 43.04 (1.6913 - 1.6945)
Out-of-round (X - Y)	
Standard	
Main journal	Less than 0.005 (0.0002)
Pin journal	Less than 0.0025 (0.0001)
Taper (A - B)	
Standard	
Main journal	Less than 0.005 (0.0002)
Pin journal	Less than 0.0025 (0.0001)
Runout [TIR]	
Standard	Less than 0.025 (0.0010)
Limit	Less than 0.05 (0.0020)
Free end play	
Standard	0.10 - 0.26 (0.0039 - 0.0102)
Limit	0.30 (0.0118)

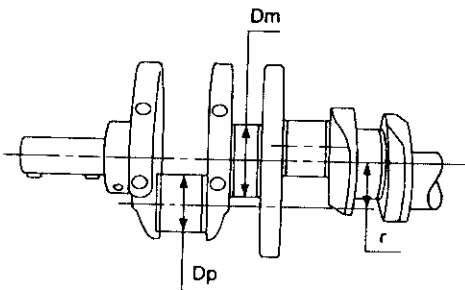

SEM954C

Out-of-round (X) - (Y)  
Taper (A) - (B)

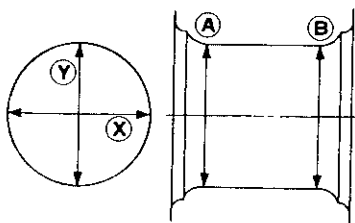

EM715

### AVAILABLE MAIN BEARING

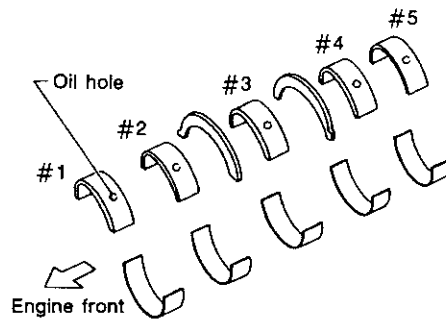

SEM685D

### Main bearing (Standard)

Unit: mm (in)

Grade number	Thickness "T"	Width "W"	Identification color (mark)
0	1.977 - 1.980 (0.0778 - 0.0780)	18.9 - 19.1 (0.744 - 0.752)	Black (A)
1	1.980 - 1.983 (0.0780 - 0.0781)		Brown (B)
2	1.983 - 1.986 (0.0781 - 0.0782)		Green (C)
3	1.986 - 1.989 (0.0782 - 0.0783)		Yellow (D)
4	1.989 - 1.992 (0.0783 - 0.0784)		Blue (E)
5	1.992 - 1.995 (0.0784 - 0.0785)		Pink (F)
6	1.995 - 1.998 (0.0785 - 0.0787)	No color (G)	

### Main bearing (Undersize)

Unit: mm (in)

Undersize	Thickness "T"	Main journal diameter "Dm"
0.25 (0.0098)	2.109 - 2.117 (0.0830 - 0.0833)	Grind so that bearing clearance is the specified value.

## SERVICE DATA AND SPECIFICATIONS (SDS)

### Inspection and Adjustment (Cont'd)

#### AVAILABLE CONNECTING ROD BEARING

##### Connecting rod bearing Standard size

Unit: mm (in)

Grade number	Thickness "T"	Width "W"	Identification color (mark)
0	1.500 - 1.503 (0.0591 - 0.0592)	16.9 - 17.1 (0.665 - 0.673)	No color (A)
1	1.503 - 1.506 (0.0592 - 0.0593)		Black (B)
2	1.506 - 1.509 (0.0593 - 0.0594)		Brown (C)

#### Undersize

Unit: mm (in)

Undersize	Thickness "T"	Crank pin journal diameter "Dp"
0.08 (0.0031)	1.541 - 1.549 (0.0607 - 0.0610)	Grind so that bearing clearance is the specified value.
0.12 (0.0047)	1.561 - 1.569 (0.0615 - 0.0618)	
0.25 (0.0098)	1.626 - 1.634 (0.0640 - 0.0643)	

#### Bearing clearance

Unit: mm (in)

Main bearing clearance	
Standard	0.004 - 0.022 (0.0002 - 0.0009)
Limit	0.05 (0.0020)
Connecting rod bearing clearance	
Standard	0.020 - 0.045 (0.0008 - 0.0018)
Limit	0.65 (0.0256)

#### MISCELLANEOUS COMPONENTS

Unit: mm (in)

Camshaft sprocket runout limit [TIR]	0.25 (0.0098)
Flywheel runout limit [TIR]	0.15 (0.0059)

GI

MA

**EM**

LC

EC

EE

CL

MT

AT

EO

EA

RA

BR

ST

RS

RT

HA

EL

EOX

# ENGINE LUBRICATION & COOLING SYSTEMS

## SECTION **LC**

GI

MA

EM

**LC**

EC

FE

CL

MT

AT

PD

FA

RA

BR

ST

RS

BT

HA

EL

IDX

## CONTENTS

<b>PRECAUTION AND PREPARATION</b> .....	2
Precaution .....	2
Special Service Tools .....	2
<b>ENGINE LUBRICATION SYSTEM</b> .....	4
Lubrication Circuit .....	4
Oil Pressure Check .....	4
Oil Pump .....	5
Oil Filter .....	8
Oil Jet (For piston) .....	8
Oil Cooler .....	9
Turbocharger Oil Tube .....	9
<b>ENGINE COOLING SYSTEM</b> .....	10
Cooling Circuit .....	10

System Check .....	10
Refilling Engine Coolant .....	11
Water Pump .....	11
Thermostat .....	12
Water Outlet .....	13
Cooling Fan Control System (Motor driven) .....	14
Cooling Fan (Crankshaft driven) .....	14
Radiator (Aluminum type) .....	15
Turbocharger Water Tube .....	19
<b>SERVICE DATA AND SPECIFICATIONS (S.D.S.)</b> .....	20
Engine Lubrication System .....	20
Engine Cooling System .....	20

## PRECAUTION AND PREPARATION

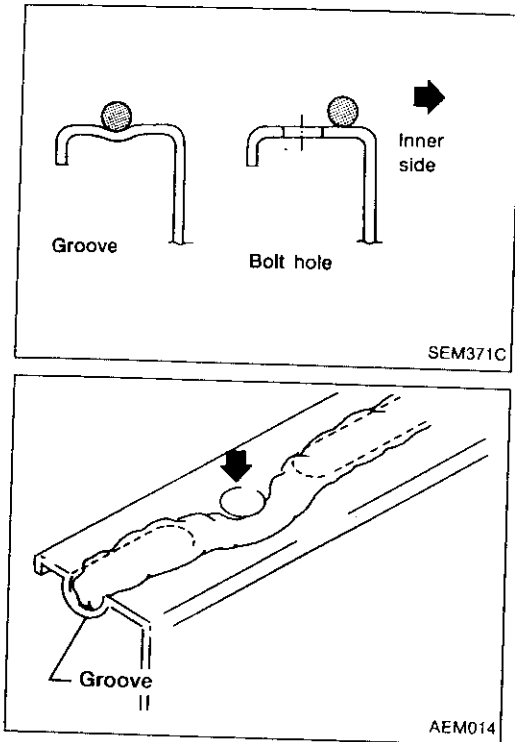

### Precaution

#### LIQUID GASKET APPLICATION PROCEDURE

- Use a scraper to remove all traces of old liquid gasket from mating surfaces and grooves. Also, completely clean any oil from these areas.
- Apply a continuous bead of liquid gasket to mating surfaces. (Use Genuine Liquid Gasket or equivalent.)
  - Be sure liquid gasket is 4.0 to 5.0 mm (0.157 to 0.197 in) wide (for oil pan).
  - Be sure liquid gasket is 2.0 to 3.0 mm (0.079 to 0.118 in) wide (in areas except oil pan).
- Apply liquid gasket to inner surface around hole perimeter area. (Assembly should be done within 5 minutes after coating.)
- Wait at least 30 minutes before refilling engine oil and engine coolant.

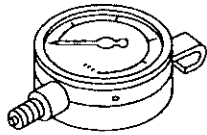
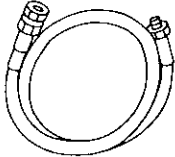
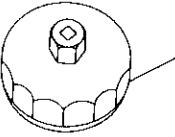
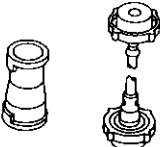

### Special Service Tools

Tool number Tool name	Description
ST25051001 Oil pressure gauge	 NT050
ST25052000 Hose	 Adapting oil pressure gauge to cylinder block NT051
KV10115801 Oil filter wrench	 Removing oil filter 14 faces Inner span 64.3 mm (2.531 in) (Face to opposite face) NT362
EG17650301 Radiator cap tester adapter	 Adapting radiator cap tester to radiator filler neck NT053

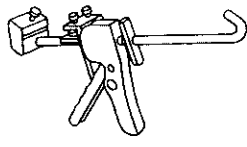

# PRECAUTION AND PREPARATION

## Special Service Tools (Cont'd)

Tool number Tool name	Description	
WS39930000 Tube presser	Pressing the tube of liquid gasket  NT052	GI MA EM
KV99103510 Radiator plate pliers A	Installing radiator upper and lower tanks  NT224	LC EC
KV99103520 Radiator plate pliers B	Removing radiator upper and lower tanks  NT225	FE CL MT

# ENGINE LUBRICATION SYSTEM

## Lubrication Circuit

← Return

↔ Feed

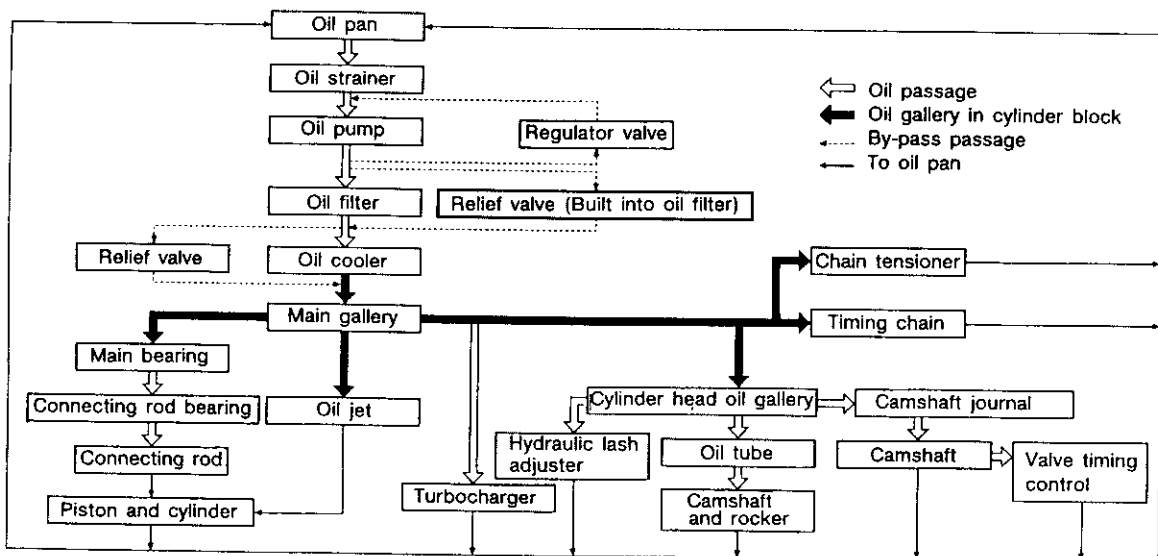
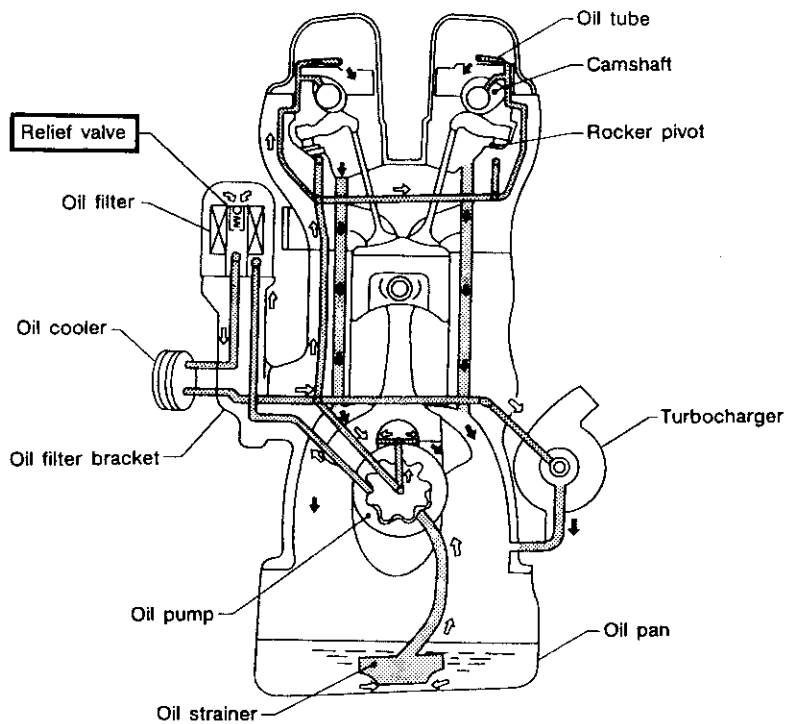

SLC969A

## ENGINE LUBRICATION SYSTEM

### Oil Pressure Check (Cont'd)

3. Install pressure gauge.
4. Start engine and warm it up to normal operating temperature.
5. Check oil pressure with engine running under no-load.

**Approximate discharge pressure: kPa (bar, kg/cm<sup>2</sup>, psi)**

**Engine speed at idle**

**More than 78 (0.78, 0.8, 11)**

**Engine speed at 3,200 rpm**

**314 - 392 (3.14 - 3.92, 3.2 - 4.0, 46 - 57)**

If difference is extreme, check oil passage and oil pump for oil leaks.

6. Install oil pressure switch with sealant.

### Oil Pump

#### REMOVAL

1. Remove front cover.
- Refer to "TIMING CHAIN" in EM section.
2. Remove oil pump cover.

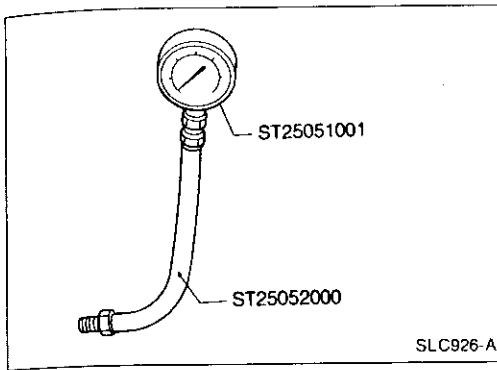

### DISASSEMBLY AND ASSEMBLY

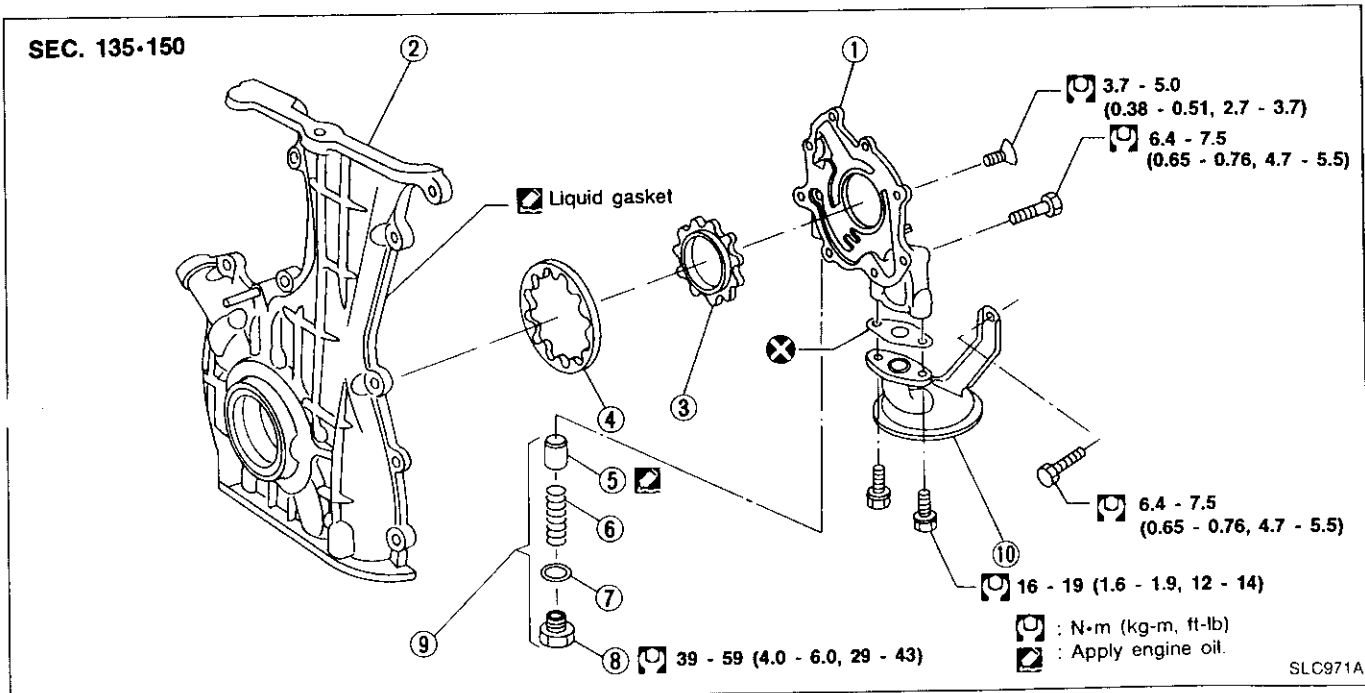

- ① Oil pump cover
- ② Front cover
- ③ Inner gear
- ④ Outer gear

- ⑤ Regulator valve
- ⑥ Spring
- ⑦ Washer

- ⑧ Plug
- ⑨ Regulator valve set
- ⑩ Oil strainer

- Always replace oil seals and gaskets with new ones.
- When installing oil pump, apply engine oil to inner and outer gears.

## ENGINE LUBRICATION SYSTEM

### Oil Pump (Cont'd)

#### INSTALLATION

- Before installing front cover assembly, remove all traces of liquid gasket from mating surface using a scraper.
- Also remove traces of liquid gasket from mating surface of cylinder block.

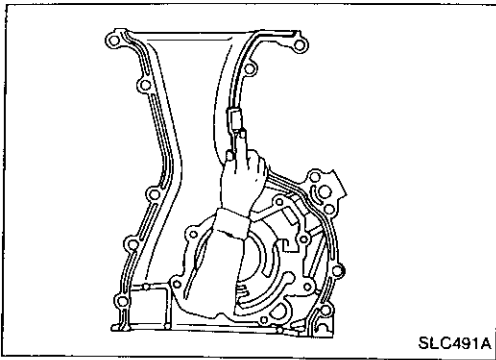

SLC491A

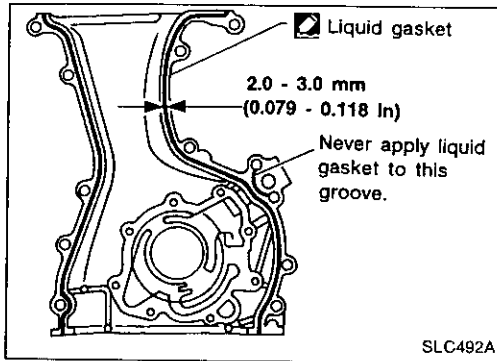

SLC492A

1. Apply a continuous bead of liquid gasket to mating surface of front cover assembly.
- Use Genuine Liquid Gasket or equivalent.
2. Installation is in reverse order of removal.

# ENGINE LUBRICATION SYSTEM

## Oil Pump (Cont'd)

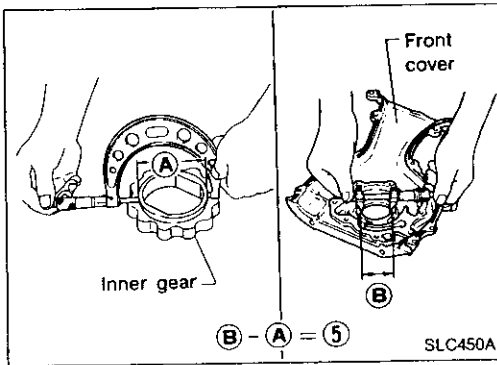
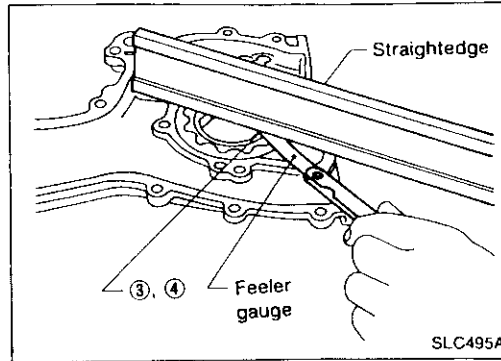
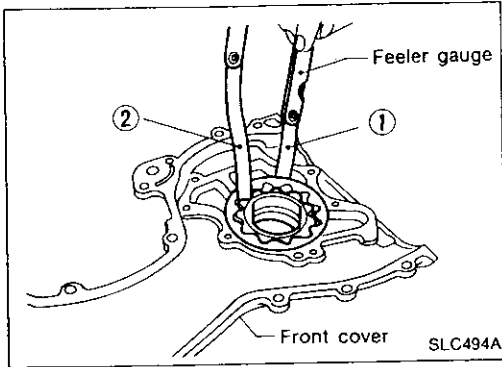

SLC860A

### INSPECTION

Using a feeler gauge, check the following clearances:

Unit: mm (in)

Body to outer gear clearance ①	0.114 - 0.200 (0.0045 - 0.0079)
Inner gear to outer gear tip clearance ②	Below 0.18 (0.0071)
Body to inner gear side clearance ③	0.05 - 0.09 (0.0020 - 0.0035)
Body to outer gear side clearance ④	0.05 - 0.11 (0.0020 - 0.0043)
Inner gear to brazed portion of housing clearance ⑤	0.045 - 0.091 (0.0018 - 0.0036)

- If the tip clearance (②) exceeds the limit, replace gear set.
- If body to gear side clearances (①, ③, ④, ⑤) exceed the limit, replace front cover assembly.

### REGULATOR VALVE INSPECTION

1. Visually inspect components for wear and damage.
2. Check oil pressure regulator valve sliding surface and valve spring.
3. Coat regulator valve with engine oil. Check that it falls freely into the valve hole by its own weight.

If damaged, replace regulator valve set or front cover assembly.

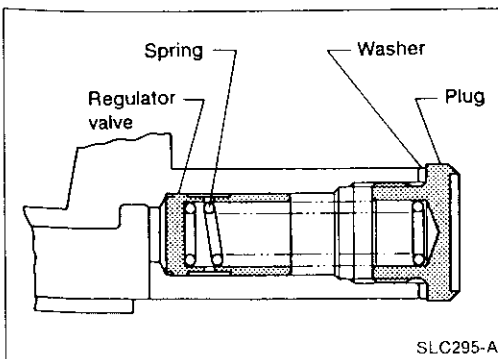

SLC295-A

GI

VA

EM

LC

EC

FE

CL

MT

AT

PD

FA

RA

BR

ST

RS

BT

HA

EL

IDX

## ENGINE LUBRICATION SYSTEM

### Oil Pump (Cont'd)

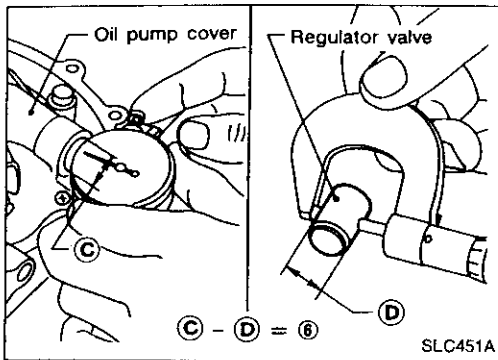

4. Check regulator valve to oil pump cover clearance.

Clearance:

⑥ : 0.040 - 0.097 mm (0.0016 - 0.0038 in)

If it exceeds the limit, replace oil pump cover.

### Oil Filter

The oil filter is a small, full-flow cartridge type and is provided with a relief valve.

- The new and existing oil filter designs differ from each other and are not interchangeable.
- Use Tool KV10115801 for removing oil filter.

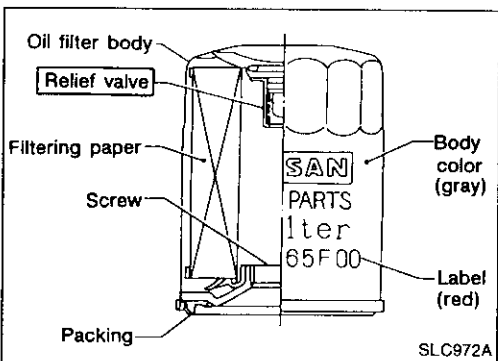

### Oil Jet (For piston)

#### INSPECTION

1. Blow through outlet of oil jet and make sure that air comes out of inlet.
2. Push cut-off valve of oil jet bolt with a clean resin or brass rod and make sure that cut-off valve moves smoothly with proper repulsion.

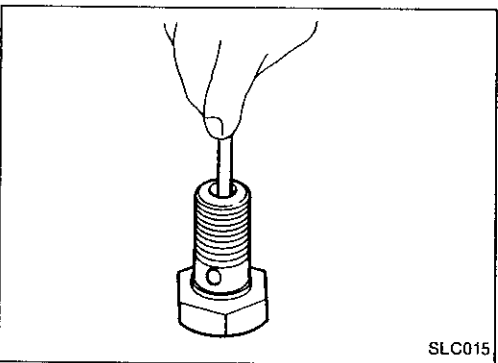

When installing oil jet, align oil jet's boss with hole on cylinder block.

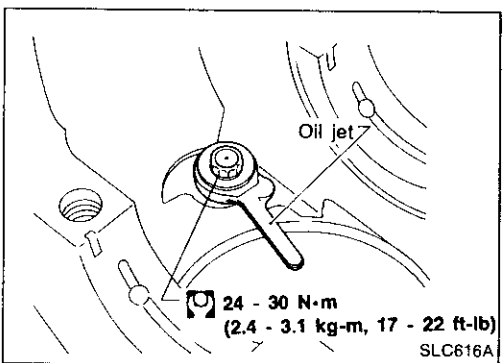

# ENGINE LUBRICATION SYSTEM

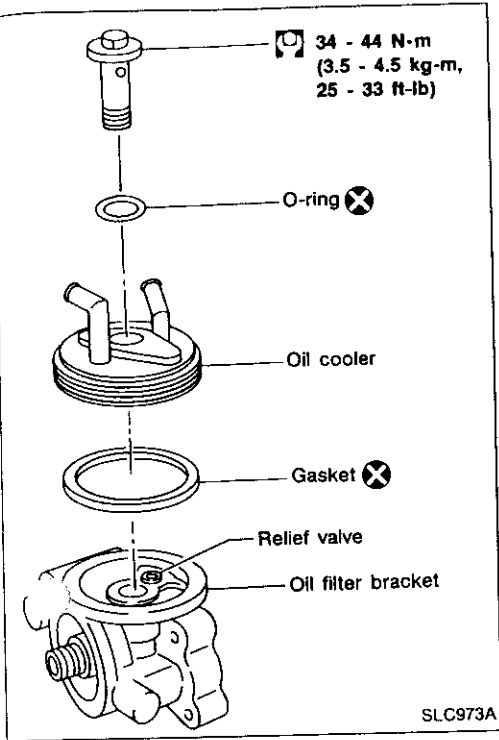

## Oil Cooler

### REMOVAL AND INSTALLATION

1. Drain engine oil and coolant.
2. Remove oil cooler.
3. Installation is in reverse order of removal.

### INSPECTION

#### Oil cooler

1. Check oil cooler for cracks.
2. Check oil cooler for clogging by blowing through coolant inlet.

If necessary, replace oil cooler assembly.

#### Oil pressure relief valve

Inspect oil pressure relief valve for movement, cracks and breaks by pushing the ball. If replacement is necessary, remove valve by prying it out with a suitable tool. Install a new valve in place by tapping it.

## Turbocharger Oil Tube

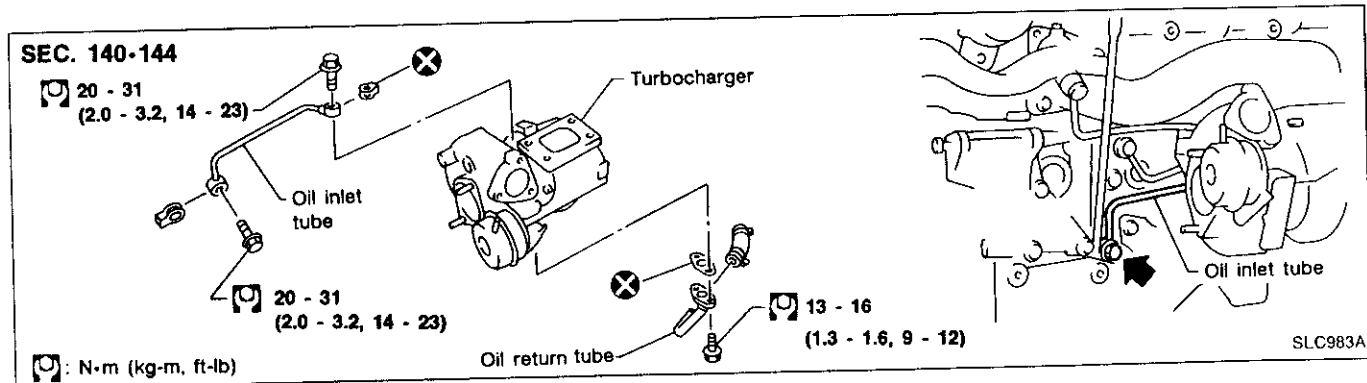

- For installation, first hand-tighten bolts connecting tubes. Then tighten bolts to the specified torques.
- Be careful not to deform tubes.
- After installation, run engine for a few minutes, and check for oil leakage.

GI

MA

EM

LC

EC

FE

CL

MT

AT

PD

FA

RA

BR

ST

RS

BT

HA

EL

IDX

# ENGINE COOLING SYSTEM

## Cooling Circuit

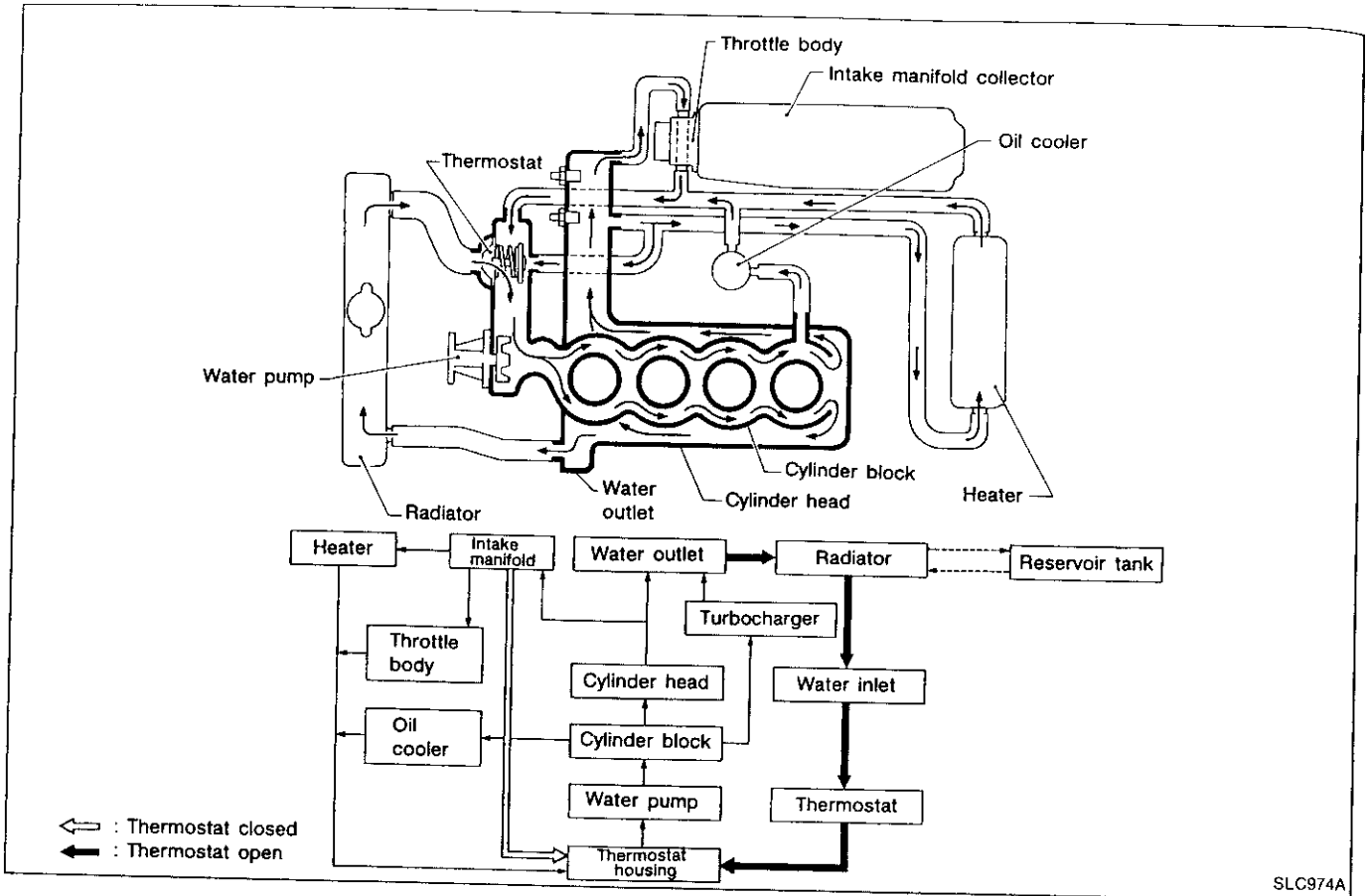

## System Check

### WARNING:

Never remove the radiator cap when the engine is hot; serious burns could be caused by high pressure fluid escaping from the radiator.

Wrap a thick cloth around cap and carefully remove the cap.



## ENGINE COOLING SYSTEM

### System Check (Cont'd)

#### CHECKING RADIATOR CAP

To check radiator cap, apply pressure to cap with a tester.

Radiator cap relief pressure:

78 - 98 kPa (0.78 - 0.98 bar, 0.8 - 1.0 kg/cm<sup>2</sup>, 11 - 14 psi)

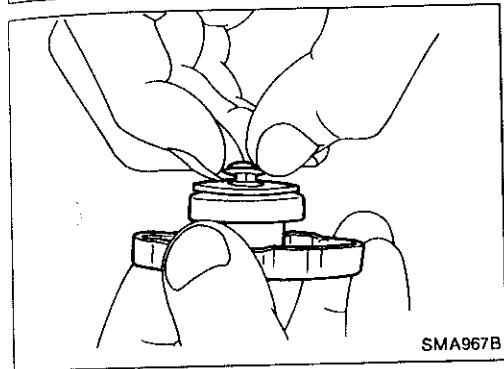
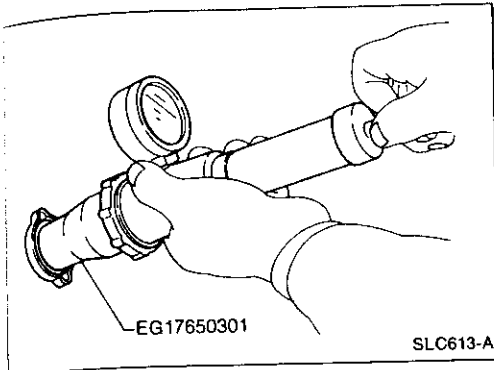

Pull the negative pressure valve to open it. Check that it closes completely when released.

#### Refilling Engine Coolant

Refer to "Changing Engine coolant" in MA section.

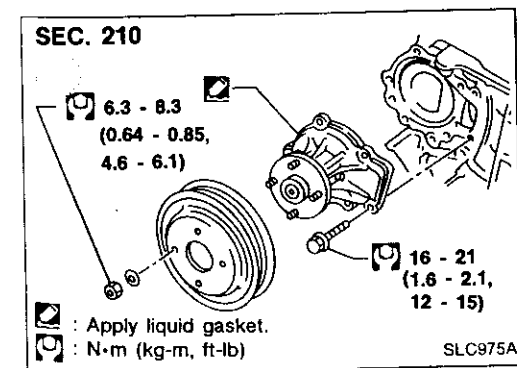

#### Water Pump

##### CAUTION:

- When removing water pump assembly, be careful not to get coolant on drive belt.
- Water pump cannot be disassembled and should be replaced as a unit.
- After installing water pump, connect hose and clamp securely, then check for leaks using radiator cap tester.

#### REMOVAL

1. Drain coolant from cylinder block and radiator.
2. Remove fan coupling with fan.
3. Remove power steering pump drive belt, alternator drive belt and air compressor drive belt.
4. Remove water pump.

GI

WA

EM

LC

EC

FE

CL

MT

AT

PD

FA

RA

BR

ST

RS

BT

HA

EL

OX

## ENGINE COOLING SYSTEM

### Water Pump (Cont'd)

#### INSPECTION

1. Check for badly rusted or corroded vanes and body assembly.
2. Check for rough operation due to excessive end play.

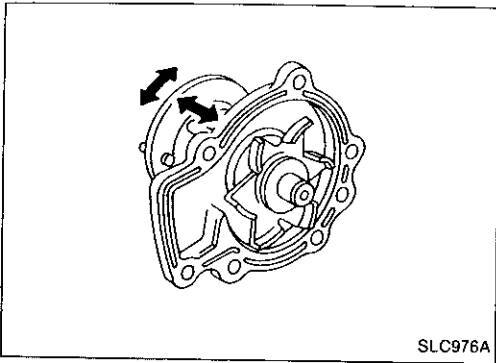

SLC976A

#### INSTALLATION



## ENGINE COOLING SYSTEM

### Thermostat (Cont'd)

#### INSPECTION

1. Check valve seating condition at ordinary room temperatures. It should seat tightly.
2. Check valve opening temperature and maximum valve lift.

Valve opening temperature	°C (°F)	76.5 (170)
Maximum valve lift	mm/°C (in/°F)	More than 10/90 (0.39/194)

3. Then check if valve is closed at 5°C (9°F) below valve opening temperature.

- Apply a continuous bead of liquid gasket to mating surface of water inlet. Refer to "Water Pump (LC-11)".
- After installation, run engine for a few minutes, and check for leaks.
- Be careful not to spill coolant over engine compartment. Use a rag to absorb coolant.

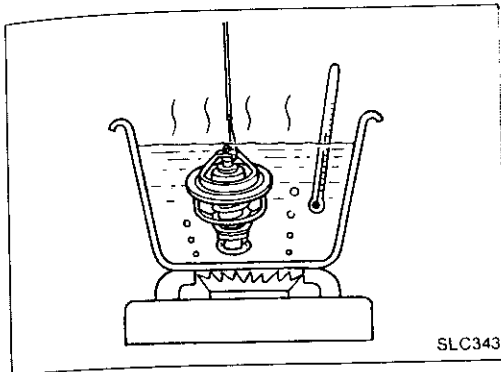

### Water Outlet

#### INSPECTION

Visually inspect for water leaks. If there is leakage, apply liquid gasket.

#### INSTALLATION

1. Use a scraper to remove old liquid gasket from water outlet.
- Also remove traces of liquid gasket from mating surface of cylinder head.
2. Apply a continuous bead of liquid gasket to mating surface of water outlet.
- Use Genuine Liquid Gasket or equivalent.

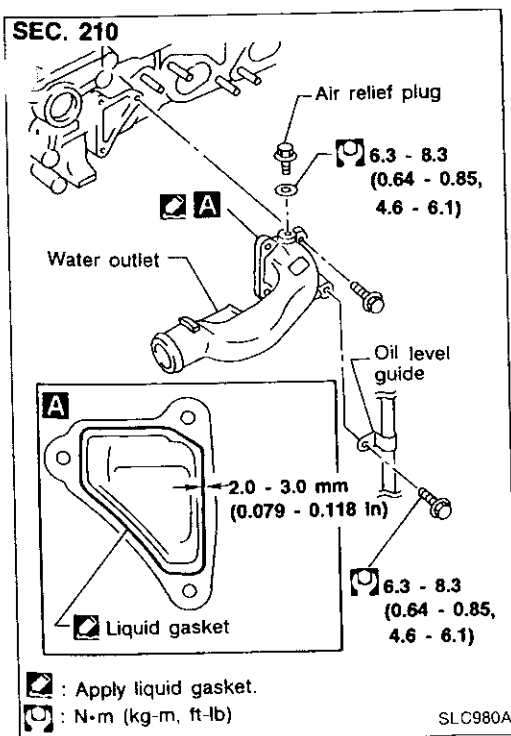

GI  
MA  
EM  
LC  
EC  
FE  
CL  
MT  
AT  
PD  
FA  
RA  
BR  
ST  
RS  
BT  
HA  
EL  
IDX

# ENGINE COOLING SYSTEM

## SEC. 214

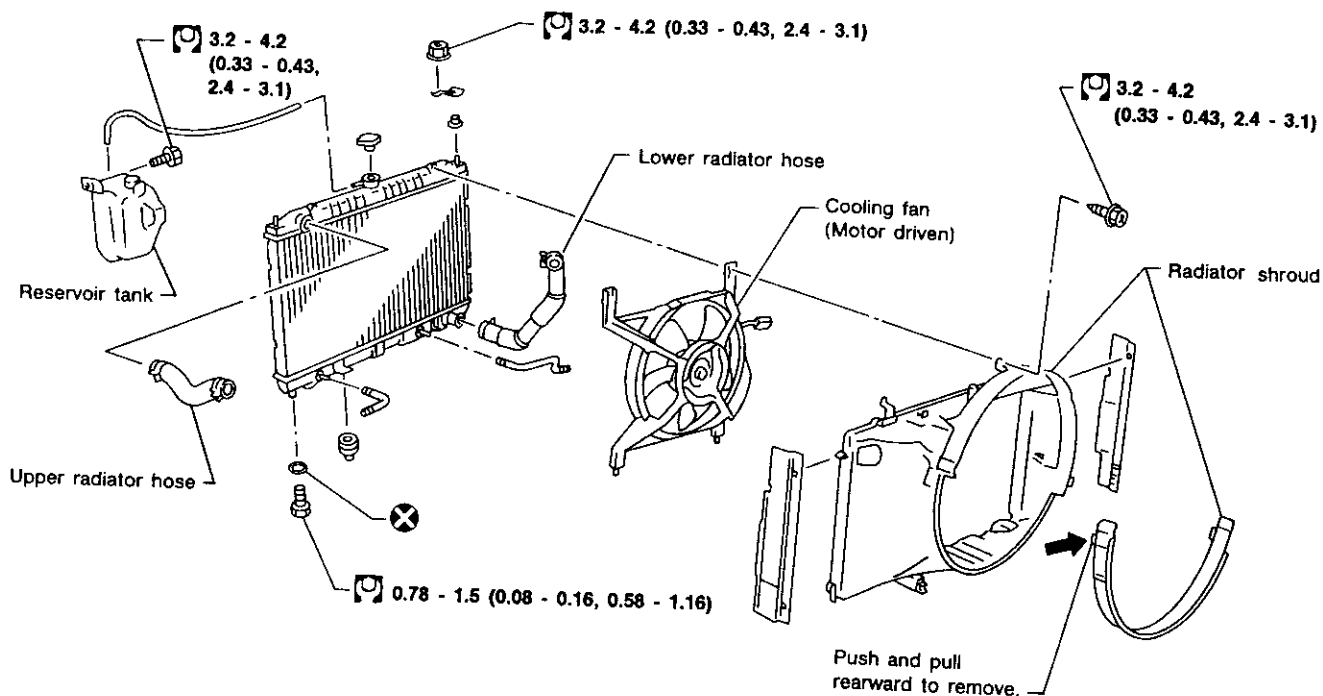

: N·m (kg-m, ft-lb)

SLC981A

## Cooling Fan Control System (Motor driven)

Fans are controlled by ECM. For details, refer to EC section.

## SEC. 210

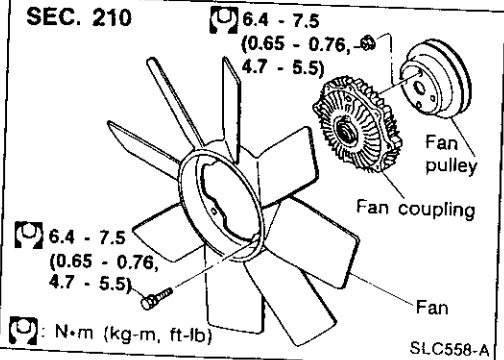

## Cooling Fan (Crankshaft driven)

### DISASSEMBLY AND ASSEMBLY

### INSPECTION

Check fan coupling for rough operation, oil leakage or bent bimetal.

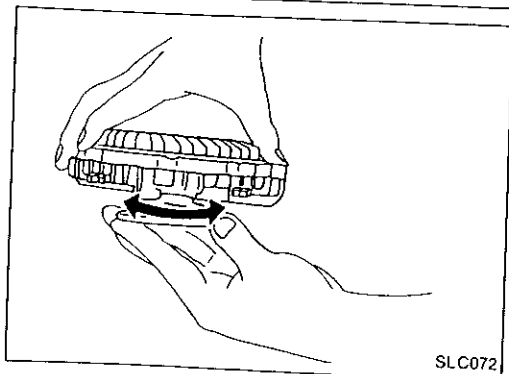

# ENGINE COOLING SYSTEM

## Radiator (Aluminum type)



GI

# ENGINE COOLING SYSTEM

## Radiator (Aluminum type) (Cont'd)

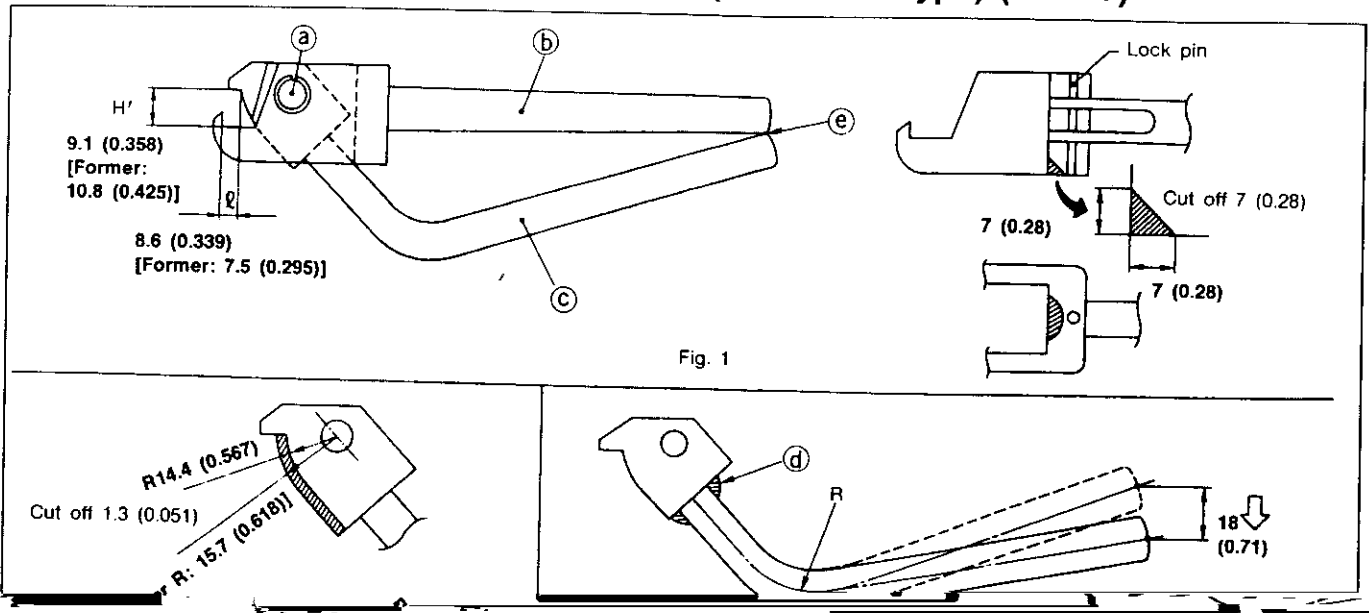

## ENGINE COOLING SYSTEM

### Radiator (Aluminum type) (Cont'd)

- In areas where Tool cannot be used, use a screwdriver to bend the edge up.

Be careful not to damage tank.

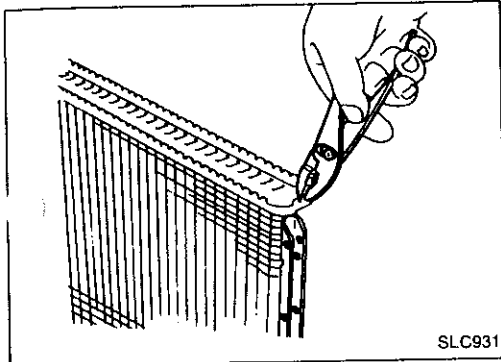
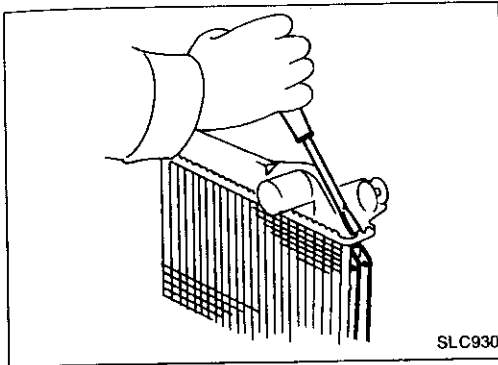

2. Make sure the edge stands straight up.
3. Remove oil cooler from tank. (A/T models only)

### ASSEMBLY

1. Install oil cooler. (A/T models only)  
Pay attention to direction of conical washer.

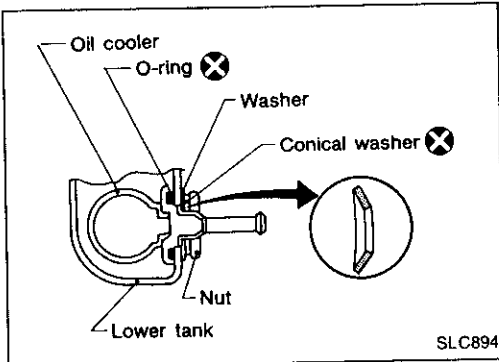

2. Clean contact portion of tank.

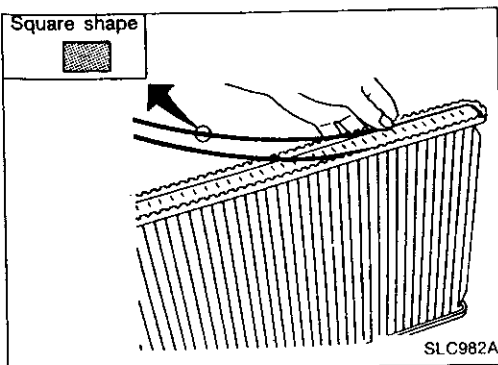
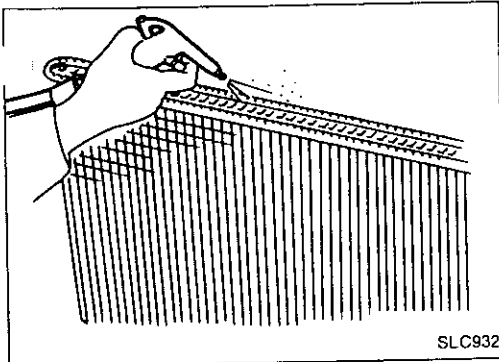

3. Install sealing rubber.  
Push it in with fingers.  
Be careful not to twist sealing rubber.

GI

MA

EM

LC

EC

FE

CL

MT

AT

PD

FA

RA

BR

ST

RS

BT

HA

EL

IDX

## ENGINE COOLING SYSTEM

### Radiator (Aluminum type) (Cont'd)

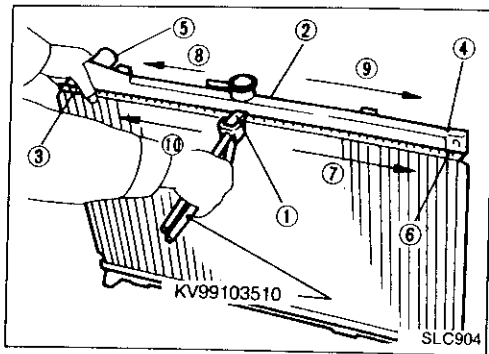

4. Caulk tank in specified sequence with Tool.  
Be careful not to excessively caulk the radiator with circular shaped rubber. The Tool is not designed for the standard caulking height (H).

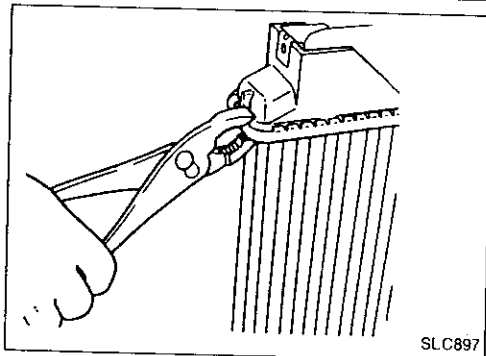
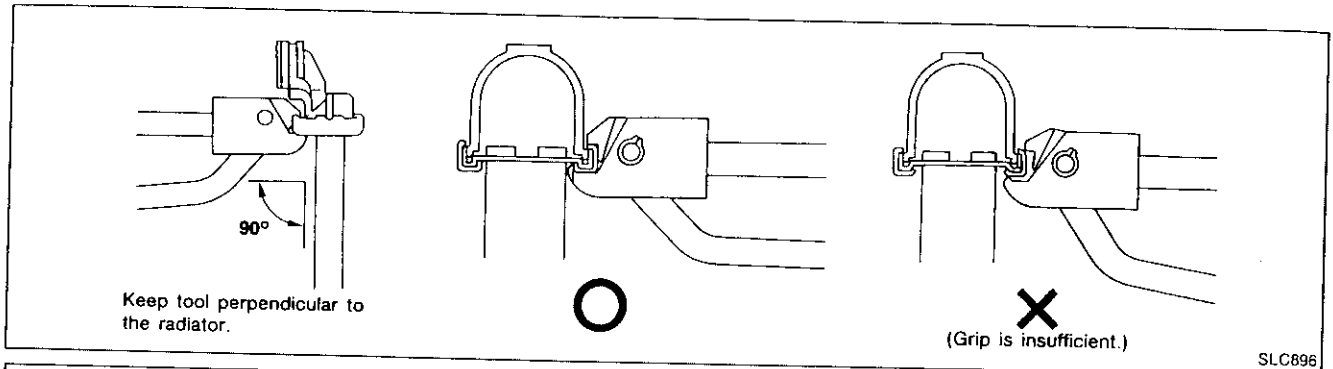

- Use pliers in the locations where Tool cannot be used.

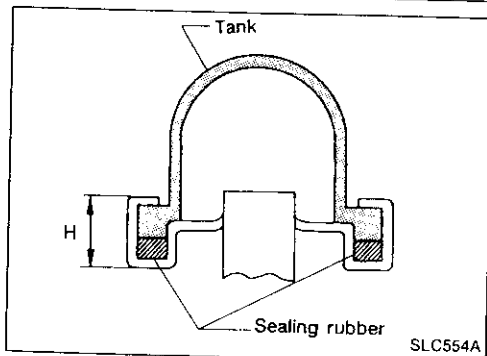

5. Make sure that the rim is completely crimped down.  
**Standard height "H":**  
8.0 - 8.4 mm (0.315 - 0.331 in)
6. Confirm that there is no leakage.  
**Refer to Inspection.**

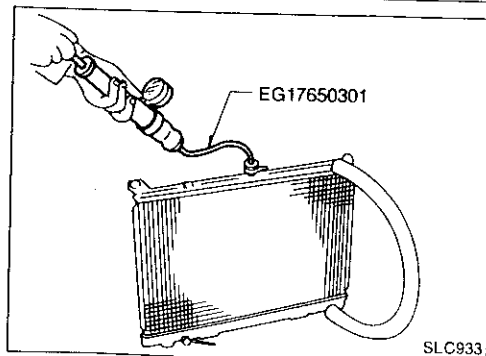

### INSPECTION

Apply pressure with Tool.

**Specified pressure value:**

157 kPa (1.57 bar, 1.6 kg/cm<sup>2</sup>, 23 psi)

### WARNING:

To prevent the risk of the hose coming undone while under pressure, securely fasten it down with a hose clamp.  
Attach a hose to the oil cooler as well. (A/T models only)



# ENGINE COOLING SYSTEM

## Turbocharger Water Tube

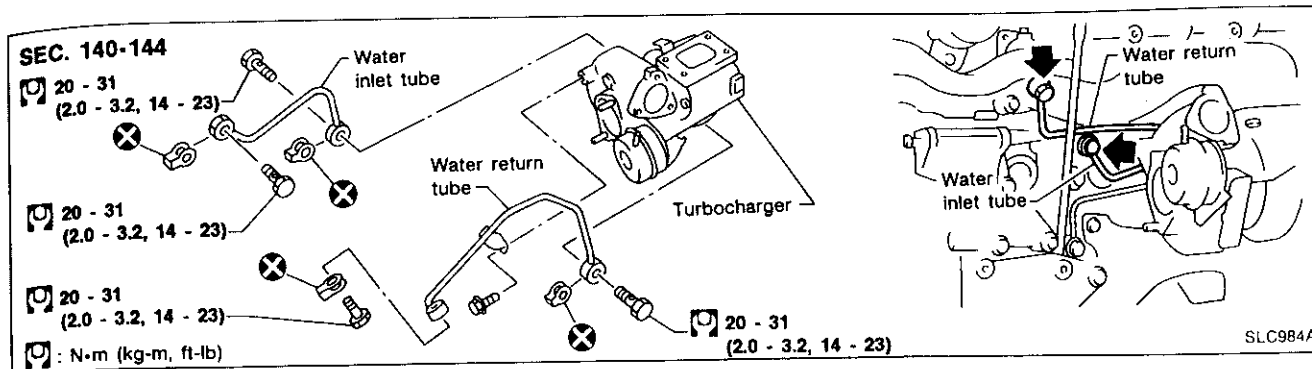

- When installing water tubes, first hand-tighten bolts connecting tubes, then slightly tighten bracket securing bolts. Finally, tighten bolts securely.
- Be careful not to deform tubes.
- After installation, run engine for a few minutes, and check for water leakage.

GI

MA

EM

LC

EC

FE

CL

MT

AT

PD

FA

RA

BR

ST

RS

BT

HA

EL

IDX

## SERVICE DATA AND SPECIFICATIONS (S.D.S.)

### Engine Lubrication System

#### Oil pressure

Engine rpm	Approximate discharge pressure kPa (bar, kg/cm <sup>2</sup> , psi)
Idle speed	More than 78 (0.78, 0.8, 11)
3,200	314 - 392 (3.14 - 3.92, 3.2 - 4.0, 46 - 57)

#### Regulator valve

Unit: mm (in)	
Regulator valve to oil pump cover clearance	0.040 - 0.097 (0.0016 - 0.0038)

#### Oil pump

Unit: mm (in)	
Body to outer gear clearance	0.114 - 0.200 (0.0045 - 0.0079)
Inner gear to outer gear tip clearance	Below 0.18 (0.0071)
Body to inner gear side clearance	0.05 - 0.09 (0.0020 - 0.0035)
Body to outer gear side clearance	0.05 - 0.11 (0.0020 - 0.0043)
Inner gear to brazed portion of housing clearance	0.045 - 0.091 (0.0018 - 0.0036)

### Engine Cooling System

#### Cooling system leakage test

Unit: kPa (bar, kg/cm <sup>2</sup> , psi)	
Testing pressure	157 (1.57, 1.6, 23)

#### Radiator cap

Unit: kPa (bar, kg/cm <sup>2</sup> , psi)	
Relief pressure	78 - 98 (0.78 - 0.98, 0.8 - 1.0, 11 - 14)

#### Thermostat

Valve opening temperature	°C (°F)	76.5 (170)
Max. valve lift	mm/°C (in/°F)	More than 10/90 (0.39/194)

# ENGINE CONTROL SYSTEM

## SECTION **EC**

GI

MA

EM

LC

**EC**

FE

## CONTENTS

<b>PREPARATION AND PRECAUTIONS</b> .....	3	Wastegate Valve Control Solenoid Valve.....	17
Supplemental Restraint System (SRS) "AIR BAG" and "SEAT BELT PRE-TENSIONER".....	3	Recirculation Valve.....	17
Engine Fuel & Emission Control System.....	4	Boost Pressure Sensor.....	18
<b>ENGINE AND EMISSION CONTROL OVERALL SYSTEM</b> .....	5	<b>ENGINE AND EMISSION CONTROL SYSTEM DESCRIPTION</b> .....	19
ECCS Component Parts Location.....	5	Multiport Fuel Injection (MFI) System.....	19
System Chart.....	8	Electronic Ignition (EI) System.....	22
System Diagram.....	9	Idle Air Control (IAC) System.....	24
Vacuum Hose Drawing.....	10	Fuel Pump Control.....	25
Circuit Diagram.....	11	Exhaust Gas Recirculation (EGR) and Canister Control System.....	26
<b>ENGINE AND EMISSION CONTROL PARTS DESCRIPTION</b> .....	12	Air Conditioner Cut Control.....	26
Engine Control Module (ECM)-ECCS Control Module.....	12	Valve Timing Control (VTC).....	27
Camshaft Position Sensor (CMPS).....	12	Heated Oxygen Sensor (HO2S) Heater Control.....	29
Mass Air Flow Sensor (MAFS).....	12	Cooling Fan Control.....	29
Engine Coolant Temperature Sensor (ECTS).....	13	Boost Pressure Control.....	30
Throttle Position Sensor (TPS) & Soft Closed Throttle Position (CTP) Switch.....	13	Fail-safe System.....	31
Fuel Injector.....	14	Direct Ignition System.....	33
Fuel Pressure Regulator.....	14	<b>IDLE SPEED/IGNITION TIMING/IDLE MIXTURE RATIO INSPECTION</b> .....	35
Fuel Pump.....	14	<b>TROUBLE DIAGNOSES</b> .....	41
Heated Oxygen Sensor (HO2S).....	14	Contents.....	41
Power Transistor Unit & Ignition Coil.....	15	<b>MULTIPORT FUEL INJECTION SYSTEM INSPECTION</b> .....	208
Fast Idle Cam (FIC).....	15	Releasing Fuel Pressure.....	208
Idle Air Control Valve (IACV)-Auxiliary Air Control (AAC) Valve.....	15	Fuel Pressure Check.....	208
Power Steering Oil Pressure Switch.....	15	Injector Removal and Installation.....	209
Vehicle Speed Sensor (VSS).....	16	<b>EVAPORATIVE EMISSION SYSTEM</b> .....	210
Knock Sensor (KS).....	16	Description.....	210
Exhaust Gas Recirculation (EGR) Valve.....	16	Inspection.....	210
EGR Control (EGRC)-BPT Valve.....	16	<b>CRANKCASE EMISSION CONTROL SYSTEM</b> .....	212
EGR and Canister Control Solenoid Valve.....	16	Description.....	212
Fuel Filter.....	17	Inspection.....	212
Valve Timing Control (VTC) Solenoid Valve.....	17	<b>SERVICE DATA AND SPECIFICATIONS (SDS)</b> .....	213
Carbon Canister.....	17	General Specifications.....	213
		Inspection and Adjustment.....	213

CL

MT

AT

PD

FA

RA

BR

ST

RS

BT

HA

EL

IDX

## **CONTENTS (Cont'd.)**

**When you read wiring diagrams:**

- **Read GI section, "HOW TO READ WIRING DIAGRAMS".**
- **See EL section, "POWER SUPPLY ROUTING" for power distribution circuit.**

**When you perform trouble diagnoses, read GI section, "HOW TO FOLLOW FLOW CHART IN TROUBLE DIAGNOSES" and "HOW TO PERFORM EFFICIENT DIAGNOSIS FOR AN ELECTRICAL INCIDENT".**

## PREPARATION AND PRECAUTIONS

### Supplemental Restraint System (SRS) "AIR BAG" and "SEAT BELT PRE-TENSIONER"

The Supplemental Restraint System "Air Bag" and "Seat Belt Pre-tensioner", used along with a seat belt, help to reduce the risk or severity of injury to the driver and front passenger in a frontal collision. The Supplemental Restraint System consists of air bag modules (located in the center of the steering wheel and on the instrument panel on the passenger side), seat belt pre-tensioners, a diagnosis sensor unit, warning lamp, wiring harness and spiral cable. Information necessary to service the system safely is included in the **RS** section of this Service Manual.

#### WARNING:

- To avoid rendering the SRS inoperative, which could increase the risk of personal injury or death in the event of a collision which would result in air bag inflation, all maintenance must be performed by an authorized NISSAN dealer.
- Improper maintenance, including incorrect removal and installation of the SRS, can lead to personal injury caused by unintentional activation of the system.
- All SRS air bag electrical wiring harnesses and connectors are covered with yellow outer insulation. Do not use electrical test equipment on any circuit related to the SRS.

GI

MA

EM

LC

EC

FE

CL

MT

AT

PD

FA

RA

BR

ST

RS

BT

HA

EL

IDX

## PREPARATION AND PRECAUTIONS

### Engine Fuel & Emission Control System

#### ECM

- Do not disassemble ECM (ECCS control module).
- Do not turn diagnosis mode selector forcibly.
- If a battery terminal is disconnected, the memory will return to the ECM value. The ECM will now start to

self-control at its initial value. Engine operation can vary slightly when the terminal is disconnected. However, this is not an indication of a problem. Do not replace parts because of a slight variation.

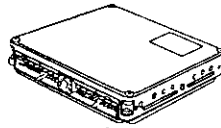

#### BATTERY

- Always use a 12 volt battery as power source.
- Do not attempt to disconnect battery cables while engine is running.

#### WIRELESS EQUIPMENT

- When installing C.B. ham radio or a mobile phone, be sure to observe the following as it may adversely affect electronic control systems depending on its installation location.
  - 1) Keep the antenna as far as possible away from the ECM.
  - 2) Keep the antenna feeder line more than 20 cm (7.9 in) away from the harness of electronic controls. Do not let them run parallel for a long distance.
  - 3) Adjust the antenna and feeder line so that the standing-wave ratio can be kept smaller.
  - 4) Be sure to ground the radio to vehicle body.

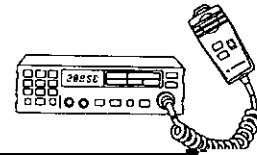

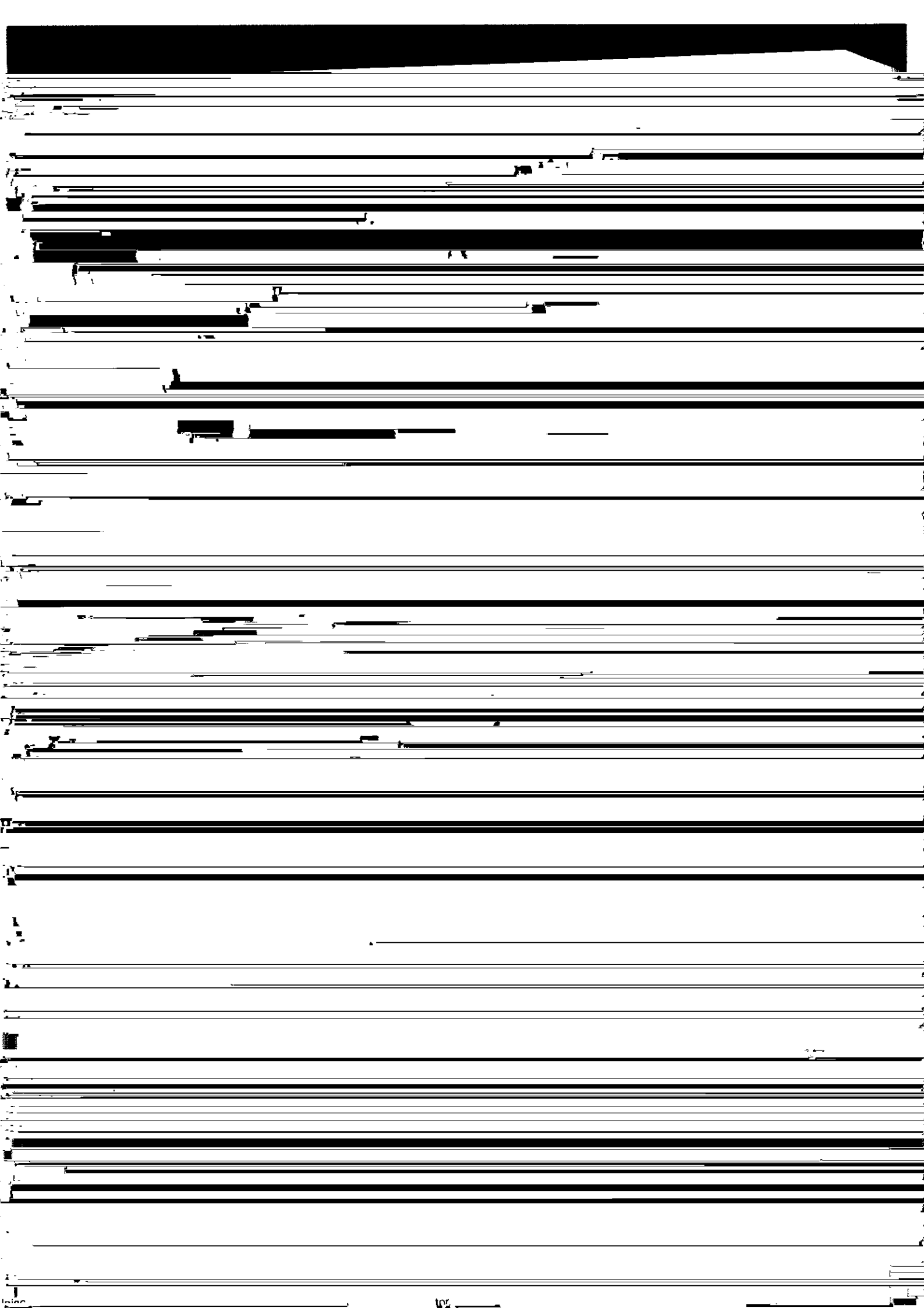

# ENGINE AND EMISSION CONTROL OVERALL SYSTEM

## ECCS Component Parts Location (Cont'd)

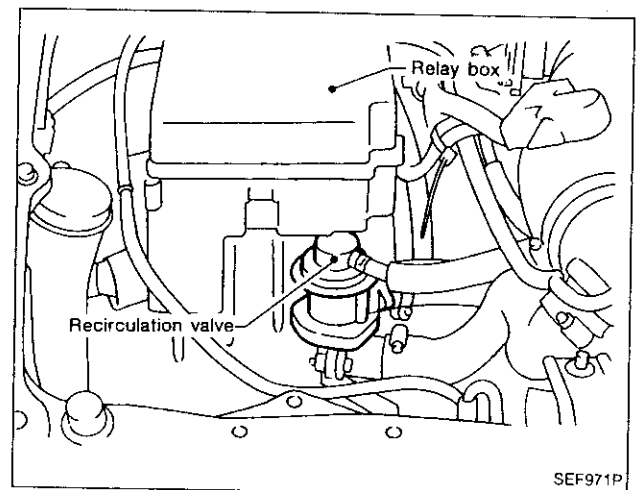
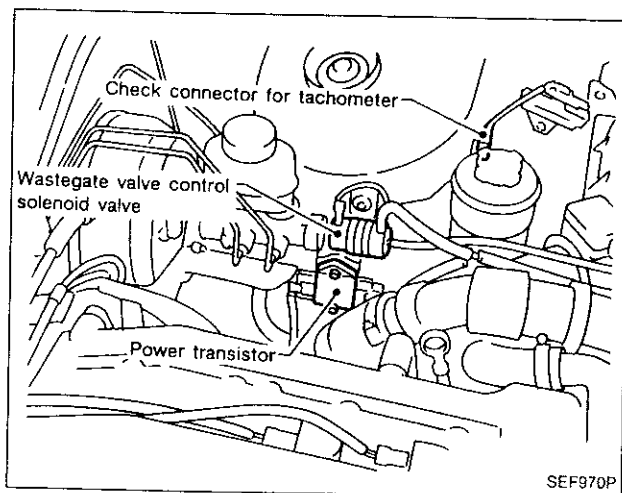
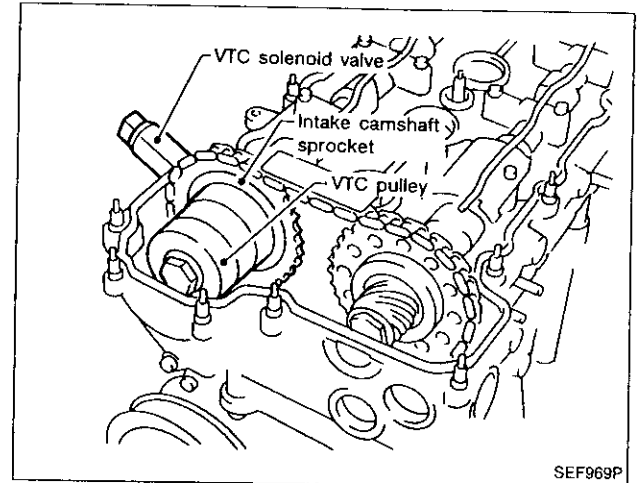
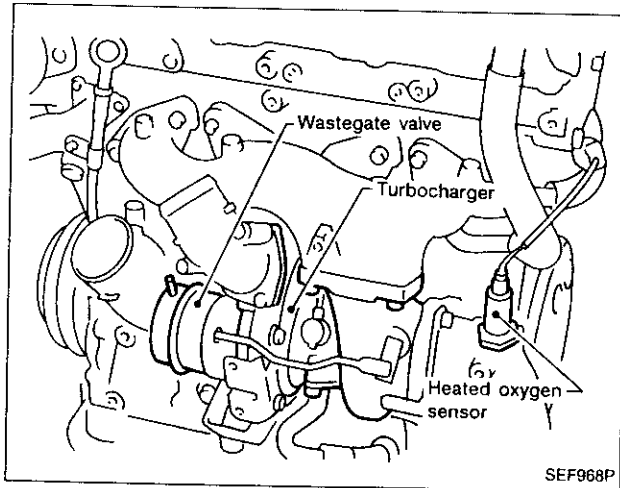
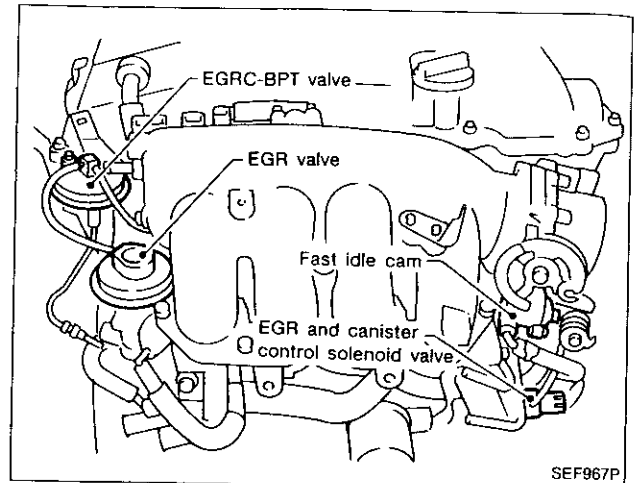
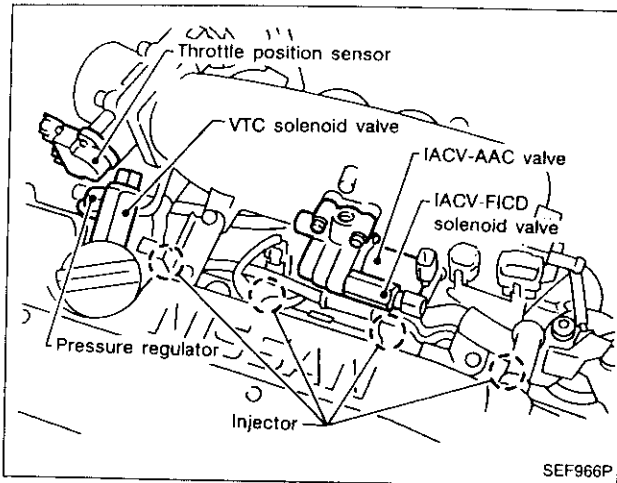



# ENGINE AND EMISSION CONTROL OVERALL SYSTEM

## ECCS Component Parts Location (Cont'd)

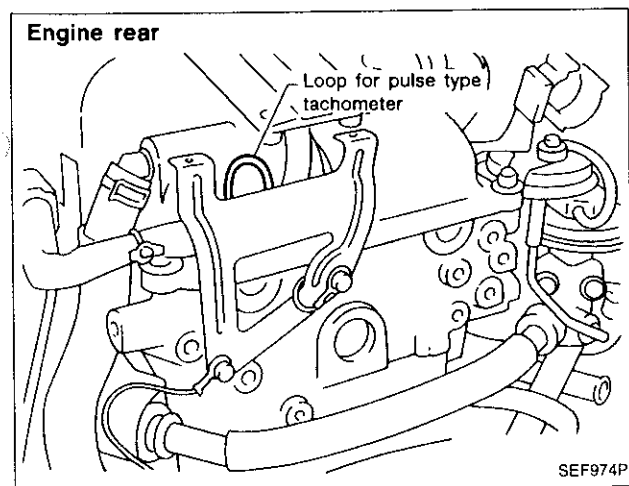
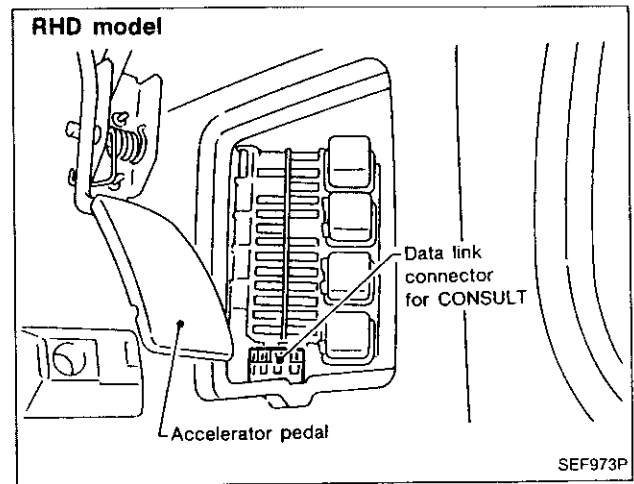
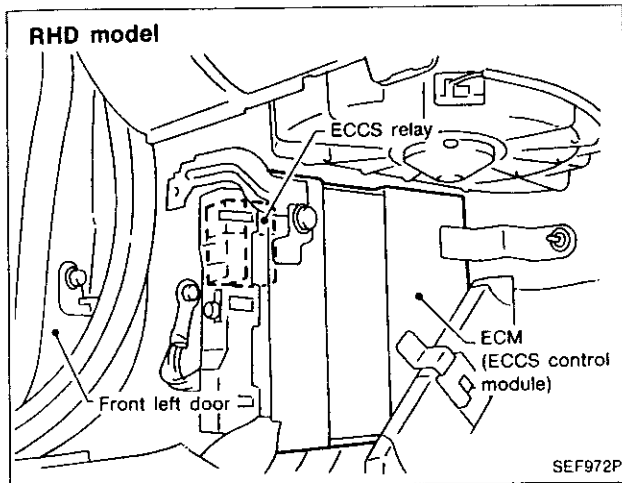
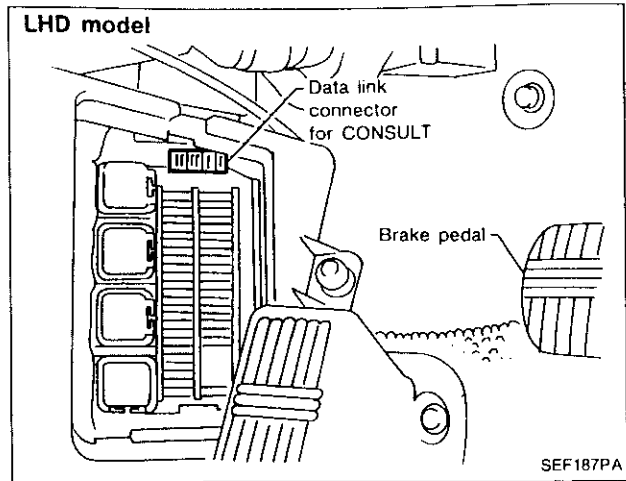
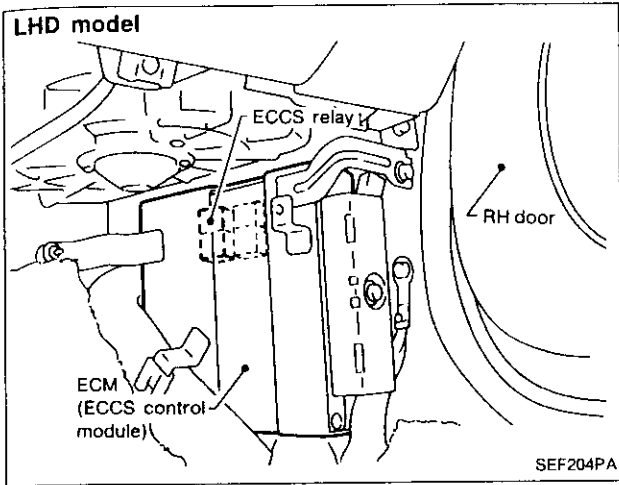

GI

MA

EM

LC

**EC**

FE

CL

MT

AT

PD

FA

RA

BR

ST

RS

BT

KA

EL

IDX

# ENGINE AND EMISSION CONTROL OVERALL SYSTEM

## System Chart

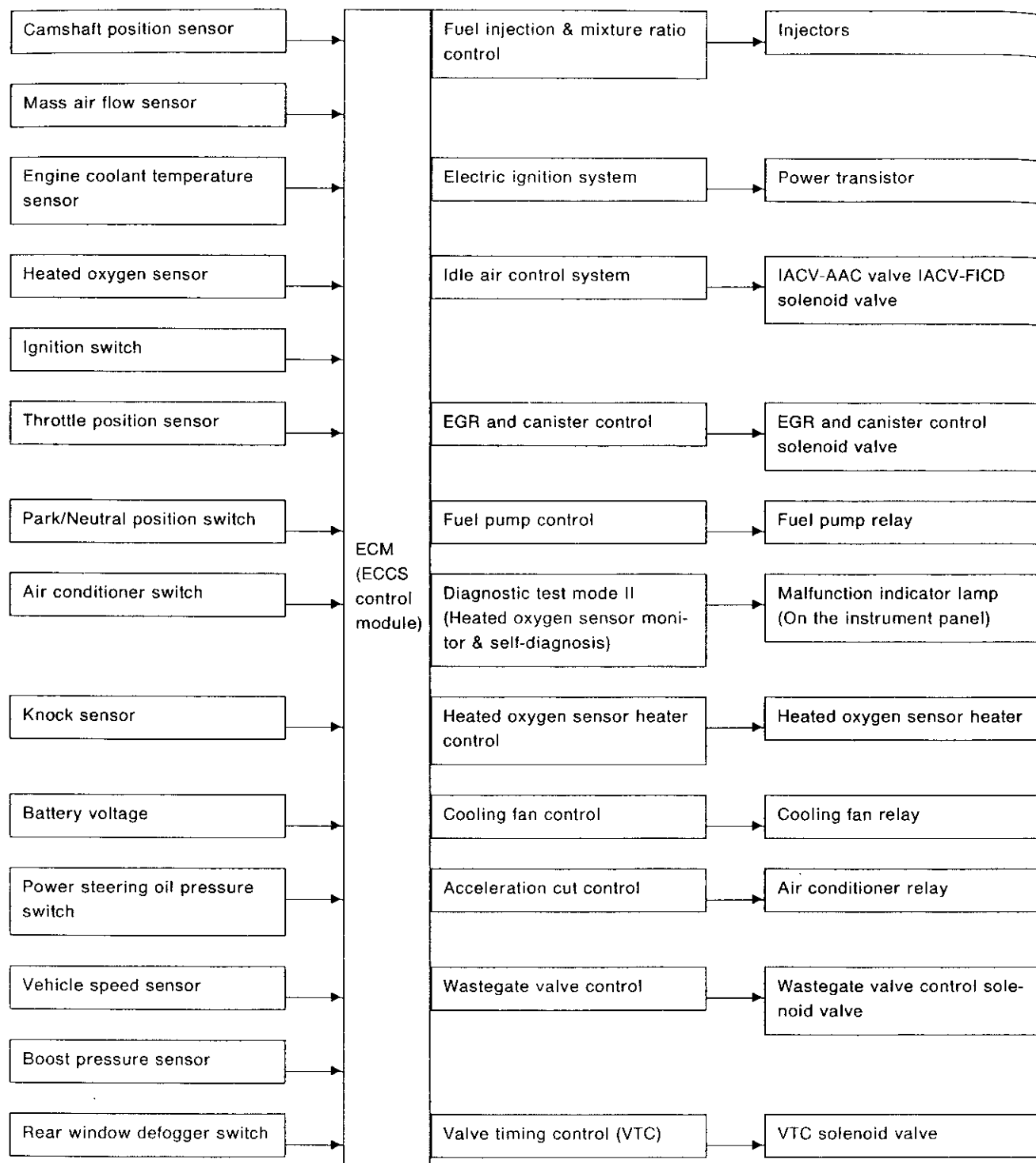

# ENGINE AND EMISSION CONTROL OVERALL SYSTEM

## System Diagram

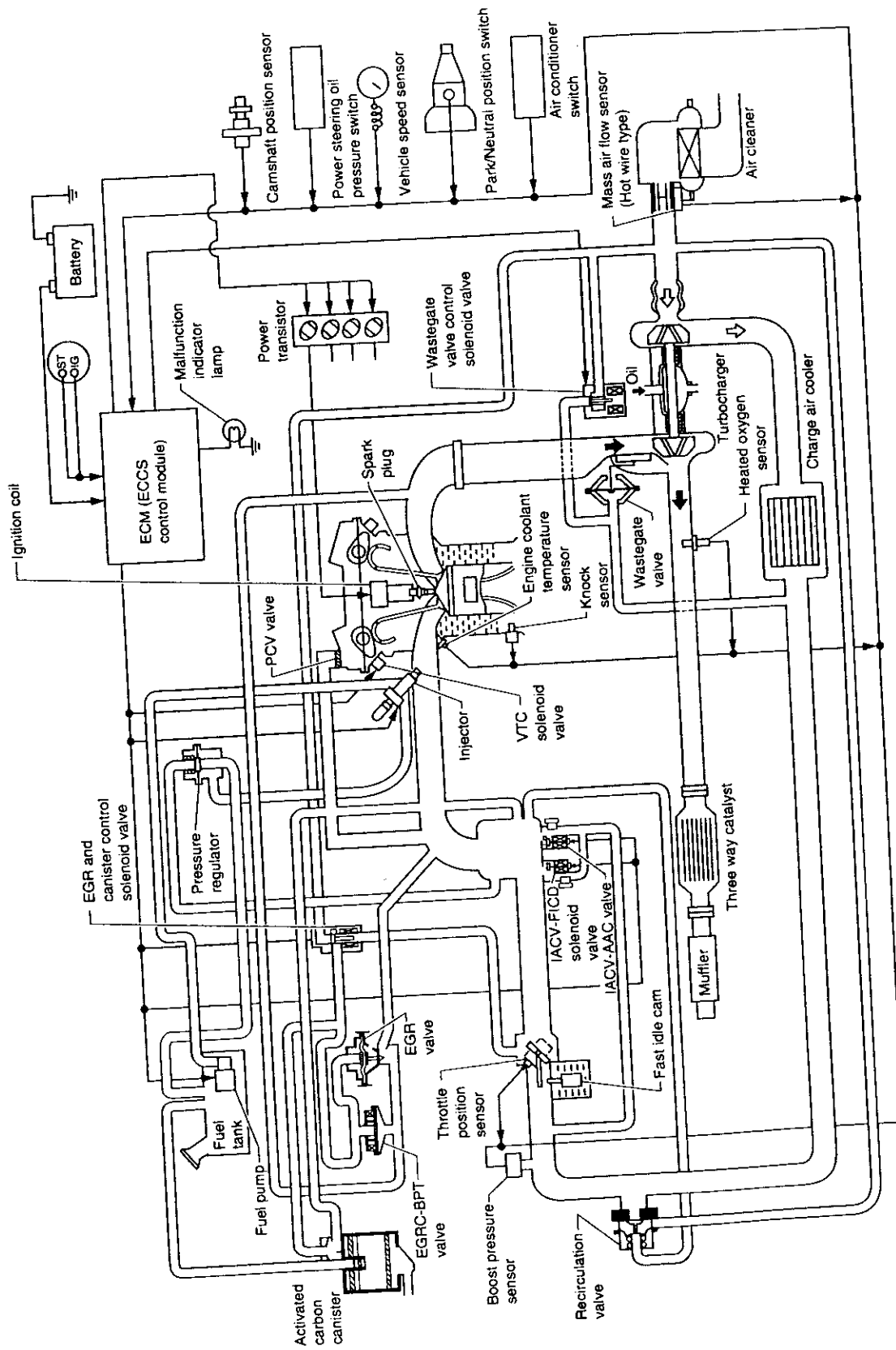

- QI
- MA
- AM
- LC
- EC**
- EP
- CL
- MT
- AT
- PD
- FA
- BA
- BR
- ST
- BS
- BT
- HA
- EL
- IDX

# ENGINE AND EMISSION CONTROL OVERALL SYSTEM

## Vacuum Hose Drawing

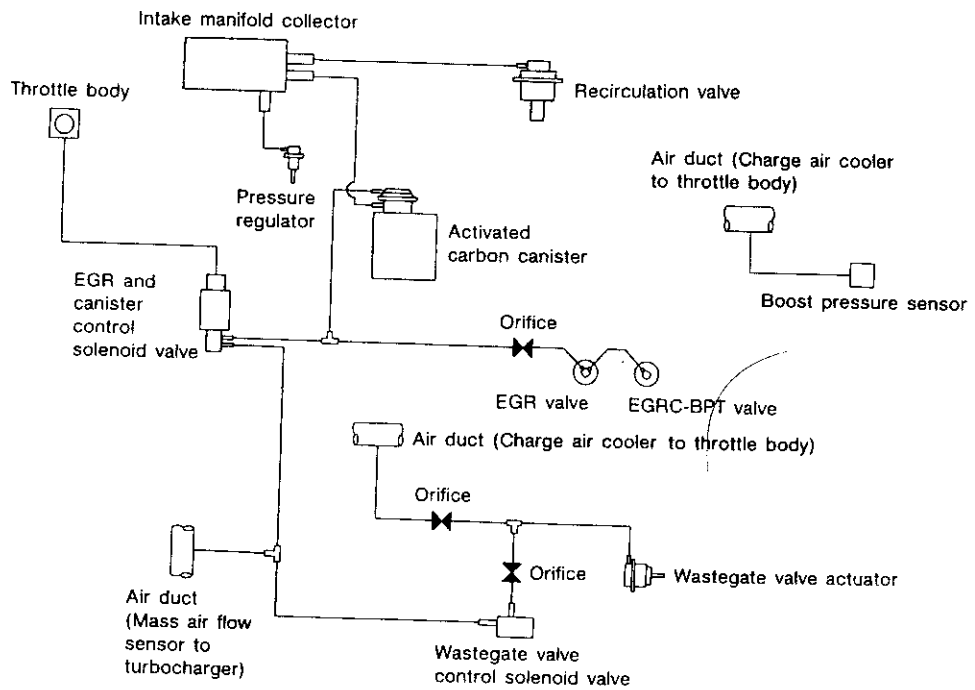
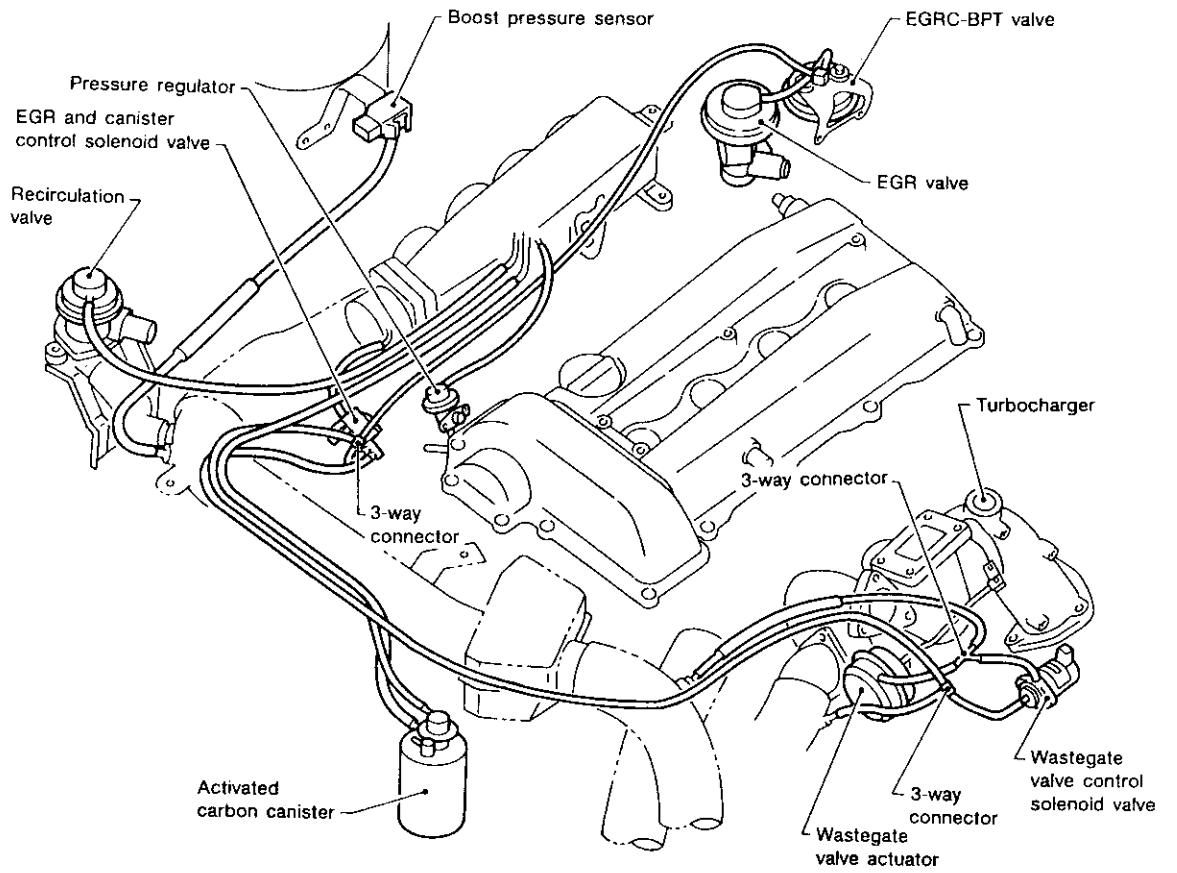



## ENGINE AND EMISSION CONTROL PARTS DESCRIPTION

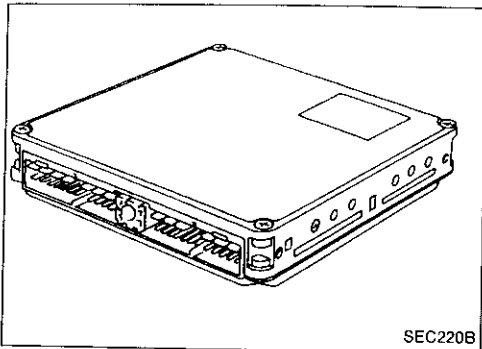

### Engine Control Module (ECM)-ECCS Control Module

The ECM consists of a microcomputer, an inspection lamp, a diagnostic test mode selector, and connectors for signal input and output and for power supply. The unit controls the engine.

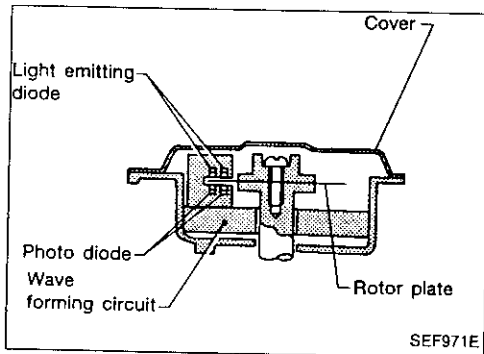

### Camshaft Position Sensor (CMPS)

The camshaft position sensor is a basic component of the ECCS. It monitors engine speed and piston position, and sends signals to the ECM to control fuel injection, ignition timing and other functions.

The camshaft position sensor has a rotor plate and a wave-forming circuit. The rotor plate has 360 slits for 1° signal and 4 slits for 180° signal. Light Emitting Diodes (LED) and photo diodes are built in the wave-forming circuit.

When the rotor plate passes between the LED and the photo diode, the slits in the rotor plate continually cut the light being transmitted to the photo diode from the LED. This generates rough-shaped pulses which are converted into on-off pulses by the wave-forming circuit, which are sent to the ECM. For diagnosis, refer to EC-109, 201.

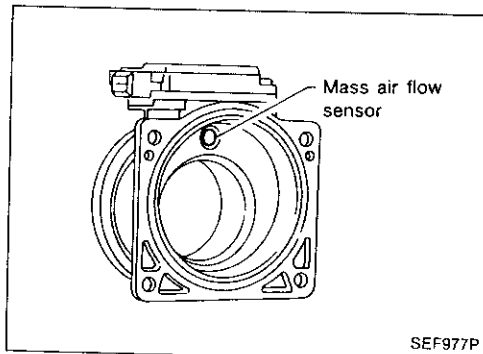
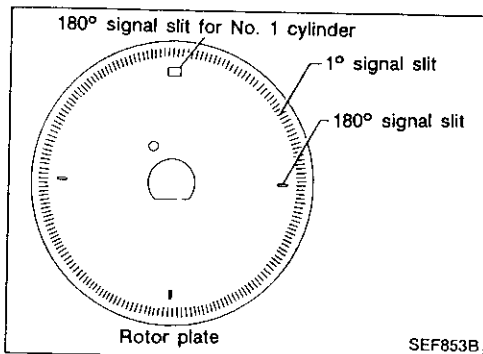

### Mass Air Flow Sensor (MAFS)

The mass air flow sensor measures the intake air flow rate by measuring a part of the entire flow. Measurements are made in such a way that the ECM receives electrical output signals varied by the amount of heat emitting from the hot film placed in the stream of the intake air.

When intake air flows into the intake manifold through a route around the hot film, the heat generated from the hot film is taken away by the air. The amount of heat reduction depends on the air flow. The temperature of the hot film is automatically controlled to a certain number of degrees.

Therefore, it is necessary to supply the hot film with more electric current in order to maintain the temperature of the hot film. The ECM detects the air flow by means of this current change. For diagnosis, refer to EC-113, 201.

# ENGINE AND EMISSION CONTROL PARTS DESCRIPTION

## ENGINE AND EMISSION CONTROL PARTS DESCRIPTION

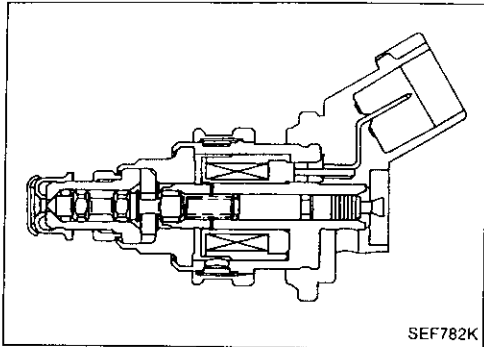

### Fuel Injector

The fuel injector is a small, elaborate solenoid valve. As the ECM sends injection signals to the injector, the coil in the injector pulls the needle valve back and fuel is released into the intake manifold through the nozzle. The injected fuel is controlled by the ECM in terms of injection pulse duration. For diagnosis, refer to EC-156, 205.

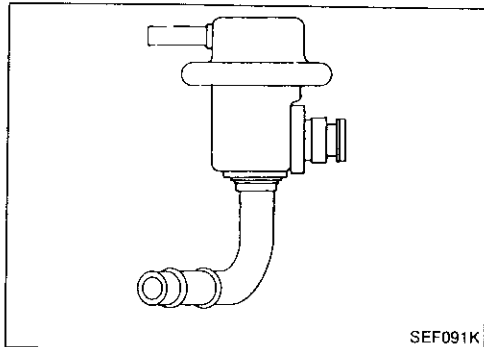

### Fuel Pressure Regulator

The pressure regulator maintains the fuel pressure at 299.1 kPa (2.991 bar, 3.05 kg/cm<sup>2</sup>, 43.4 psi). Since the injected fuel amount depends on injection pulse duration, it is necessary to maintain the pressure at the above value. For diagnosis, refer to EC-208.

### Fuel Pump





## ENGINE AND EMISSION CONTROL PARTS DESCRIPTION

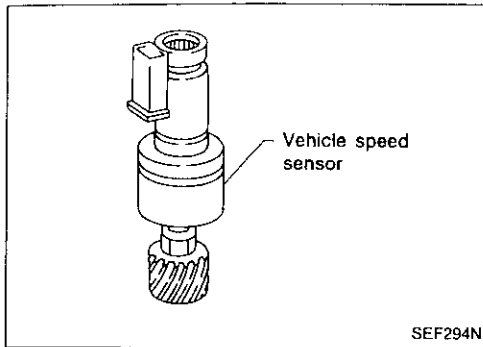

### Vehicle Speed Sensor (VSS)

The vehicle speed sensor provides a vehicle speed signal to the speedometer and the speedometer sends a signal to the ECM.

The speed sensor consists of a pulse generator which is installed in the transmission. For diagnosis, refer to EC-145, 202.

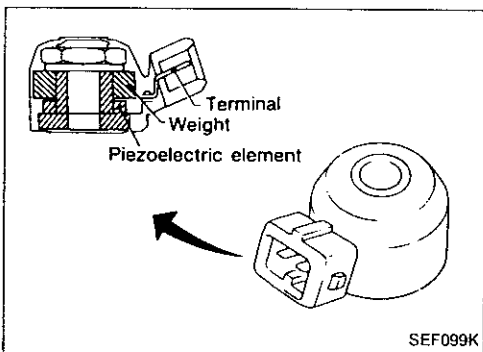

### Knock Sensor (KS)

The knock sensor is attached to the cylinder block and senses engine knocking conditions.

A knocking vibration from the cylinder block is applied as pressure to the piezoelectric element. This vibrational pressure is then converted into a voltage signal which is sent to the ECM.

For diagnosis, refer to EC-132, 205.

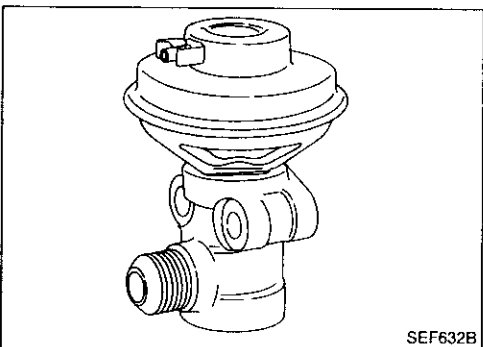

### Exhaust Gas Recirculation (EGR) Valve

The EGR valve controls the quantity of exhaust gas to be diverted to the intake manifold through vertical movement of a taper valve connected to the diaphragm. Vacuum is applied to the diaphragm in response to the opening of the throttle valve. For diagnosis, refer to EC-148, 203.

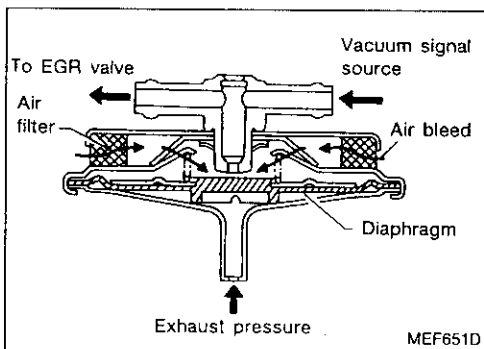

### EGR Control (EGRC)-BPT Valve

The EGRC-BPT valve monitors exhaust pressure to activate the diaphragm, controlling throttle body vacuum applied to the EGR valve. In other words, recirculated exhaust gas is controlled in response to positioning of the EGR valve or to engine operation. For diagnosis, refer to EC-148, 203.

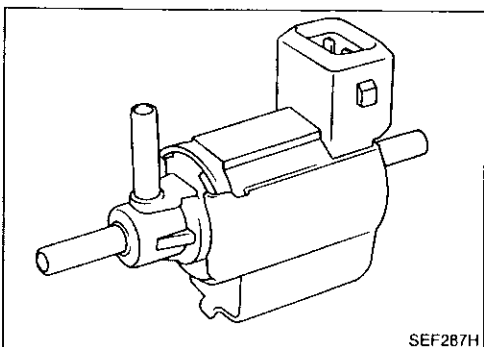

### EGR and Canister Control Solenoid Valve

The EGR and canister control solenoid valve responds to signals from the ECM. When the ECM sends an ON (ground) signal, the coil in the solenoid valve is energized. A plunger will then move to cut the vacuum signal (from the throttle body to the EGR valve and canister purge valve).

When the ECM sends an OFF signal, the vacuum signal passes through the solenoid valve. The signal then reaches the EGR valve and carbon canister. For diagnosis, refer to EC-148, 203.

# ENGINE AND EMISSION CONTROL PARTS DESCRIPTION

Fuel Filter

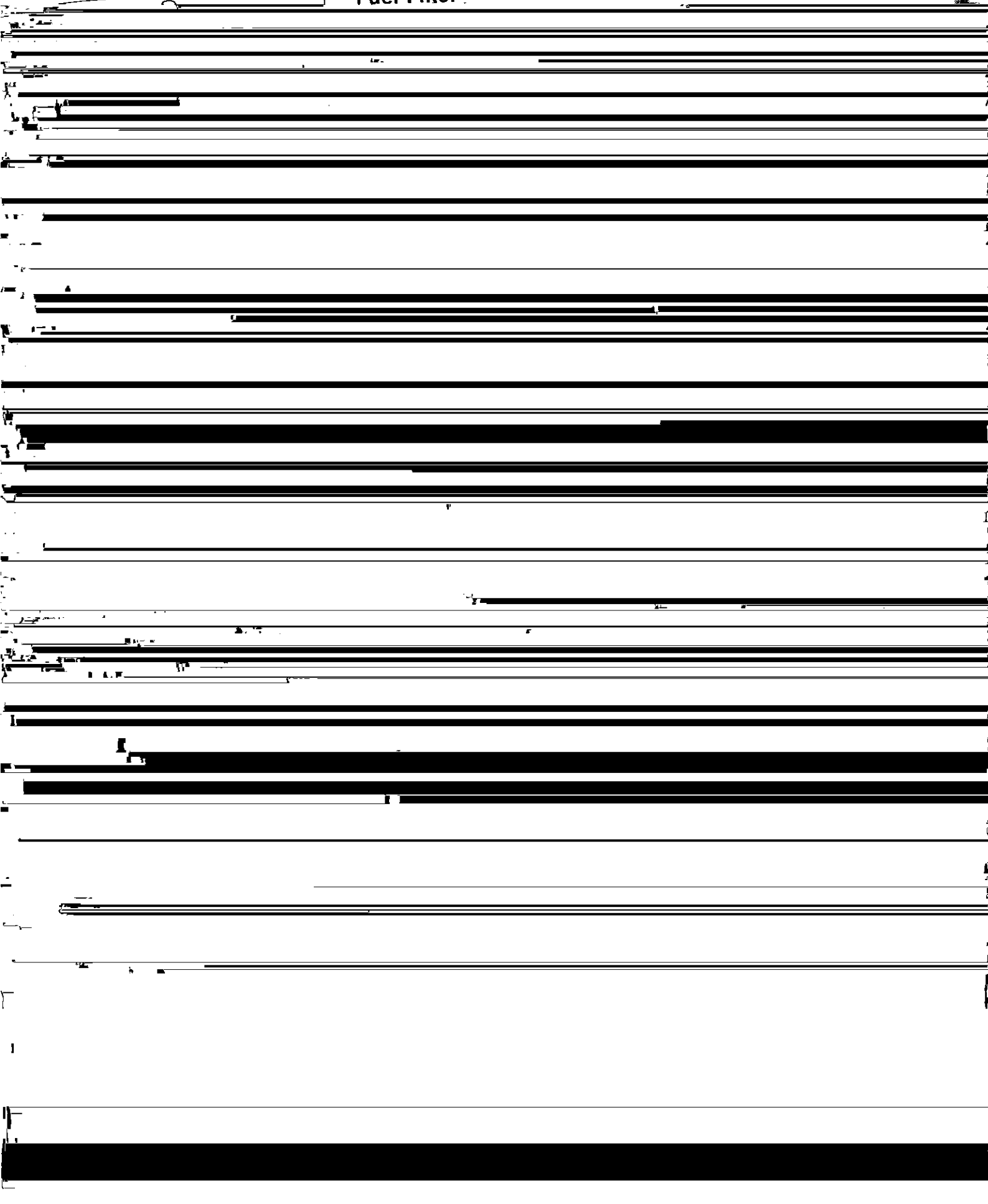

## ENGINE AND EMISSION CONTROL PARTS DESCRIPTION

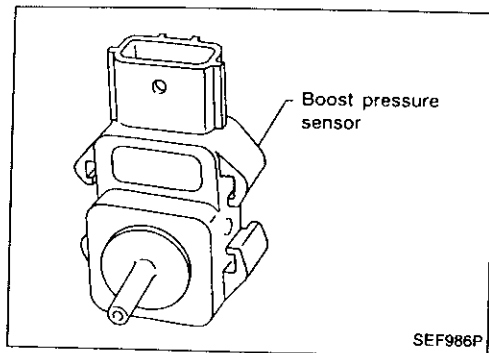

### Boost Pressure Sensor

The boost pressure sensor detects boost pressure at the upstream of the throttle body. The pressure signal is transmitted to the ECM to control the boost pressure precisely. For diagnosis, refer to EC-128, 206.

# ENGINE AND EMISSION CONTROL SYSTEM DESCRIPTION

## Multipoint Fuel Injection (MFI) System

### INPUT/OUTPUT SIGNAL LINE

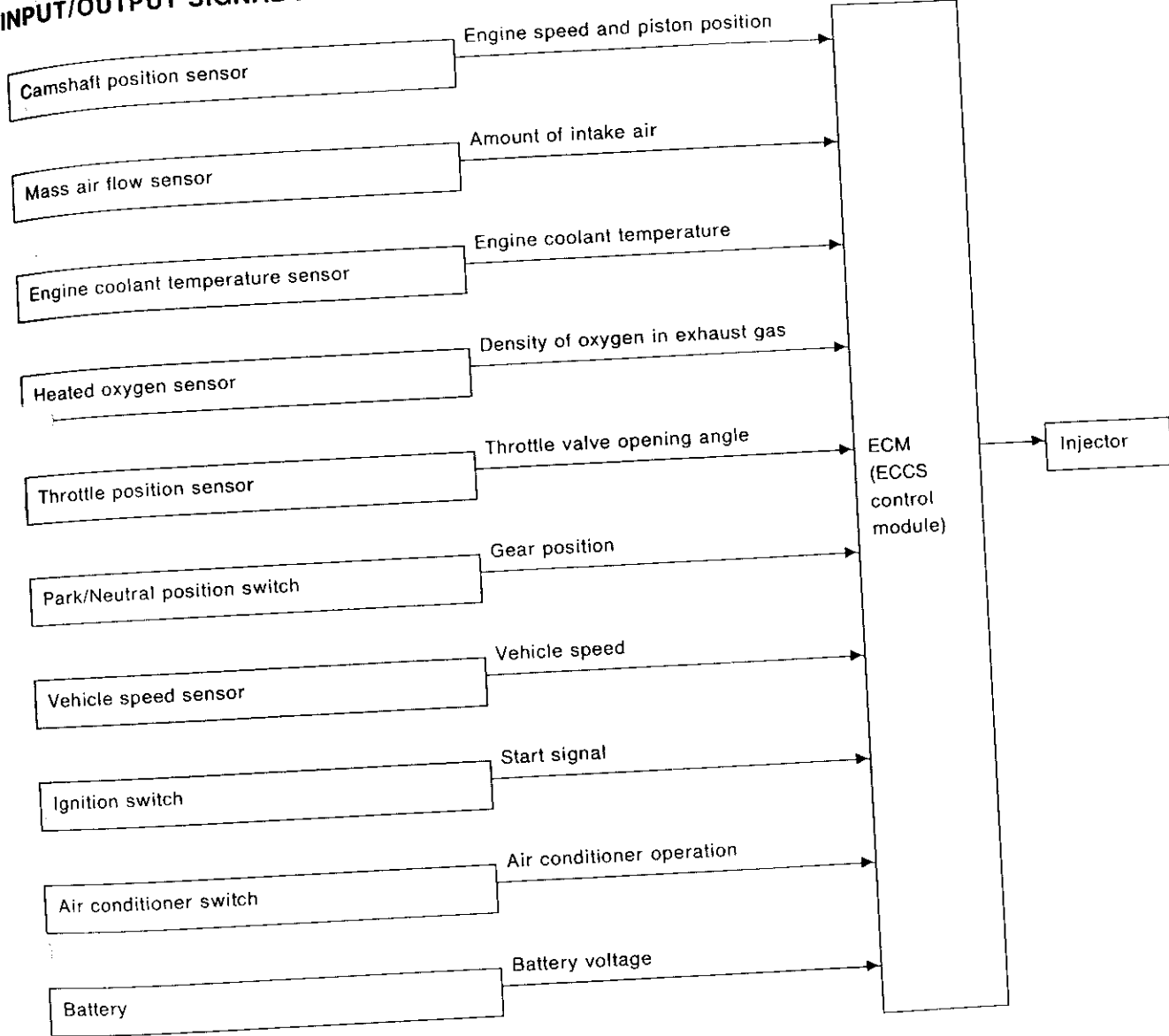

### BASIC MULTIPOINT FUEL INJECTION SYSTEM

The amount of fuel injected from the fuel injector, or the length of time the valve remains open, is determined by the ECM. The amount of fuel injected is a program value mapped in the ECM memory. In other words, the program value is preset by engine operating conditions determined by input signals (for engine speed and air intake) from both the camshaft position sensor and the mass air flow sensor.

### VARIOUS FUEL INJECTION INCREASE/DECREASE COMPENSATION

The amount of fuel injection is compensated for to improve engine performance. This will be made under various operating conditions as listed below.

- < Fuel increase >
  - 1) During warm-up
  - 2) When starting the engine
  - 3) During acceleration
  - 4) Hot-engine operation
- < Fuel decrease >
  - 1) During deceleration

GI  
VA  
EM  
LC  
EC  
EE  
CI  
MT  
AT  
FD  
FA  
RA  
BR  
ST  
RS  
BT  
HA  
EI  
DX

## ENGINE AND EMISSION CONTROL SYSTEM DESCRIPTION

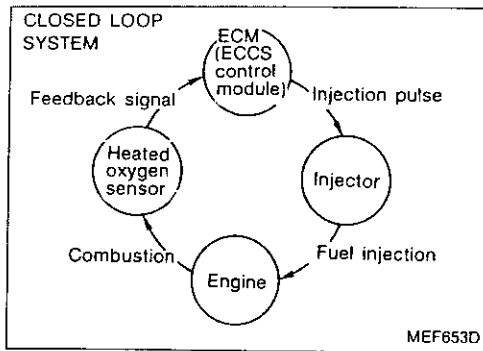

### Multiport Fuel Injection (MFI) System (Cont'd) MIXTURE RATIO FEEDBACK CONTROL

The mixture ratio feedback system is used for precise control of the mixture ratio to the stoichiometric point, so that the three way catalyst can reduce CO, HC and NO<sub>x</sub> emissions. This system uses a heated oxygen sensor in the exhaust manifold to check the air-fuel ratio. The ECM adjusts the injection pulse width according to the sensor voltage so the mixture ratio will be within the range of the stoichiometric air-fuel ratio. This stage refers to the closed loop control condition.

### OPEN LOOP CONTROL

The open loop control condition refers to that under which the ECM detects any of the following conditions and feedback control stops in order to maintain stabilized fuel combustion.

- 1) Deceleration
- 2) High-load, high-speed operation
- 3) Engine idling
- 4) Malfunction of heated oxygen sensor or its circuit
- 5) Insufficient activation of heated oxygen sensor at low engine coolant temperature
- 6) Engine starting

### MIXTURE RATIO SELF-LEARNING CONTROL

The mixture ratio feedback control system monitors the mixture ratio signal transmitted from the heated oxygen sensor. This feedback signal is then sent to the ECM to control the amount of fuel injection to provide a basic mixture ratio as close to the theoretical mixture ratio as possible. However, the basic mixture ratio is not necessarily controlled as originally designed. Both Manufacturing differences (i.e. mass air flow sensor hot wire) and characteristic changes during operation (i.e. injector clogging) directly affect mixture ratio.

Accordingly, the difference between the basic and theoretical mixture ratios is monitored in this system. This is then computed in terms of "fuel injection duration" to automatically compensate for the difference between the two ratios.

# ENGINE AND EMISSION CONTROL SYSTEM DESCRIPTION

## Multiport Fuel Injection (MFI) System (Cont'd)

### FUEL INJECTION TIMING

Two types of systems are used — sequential multiport fuel injection system and simultaneous multiport fuel injection system.

- 1) Sequential multiport fuel injection system  
Fuel is injected into each cylinder during each engine cycle according to the firing order. This system is used when the engine is running.
- 2) Simultaneous multiport fuel injection system  
Fuel is injected simultaneously into all four cylinders twice each engine cycle. In other words, pulse signals of the same width are simultaneously transmitted from the ECM. The four injectors will then receive the signals two times for each engine cycle.  
This system is used when the engine is being started and/or if the fail-safe system (CPU) is operating.

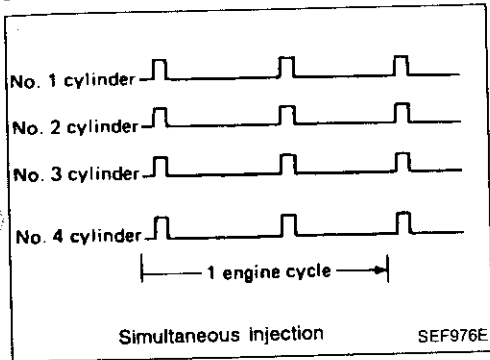
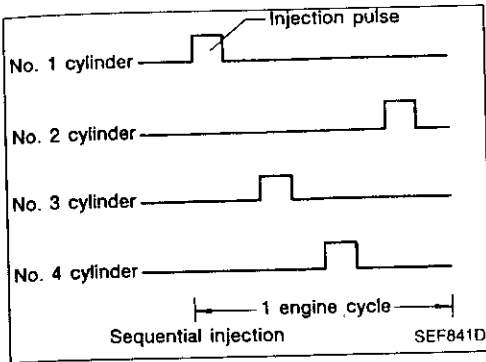

### FUEL SHUT-OFF

Fuel to each cylinder is cut off during deceleration or operation of the engine at excessively high speeds.

GI

MA

EM

LC

EC

FE

CL

MT

AT

PD

FA

RA

BR

ST

RS

BT

HA

EL

IDX

# ENGINE AND EMISSION CONTROL SYSTEM DESCRIPTION

## Electronic Ignition (EI) System

### INPUT/OUTPUT SIGNAL LINE

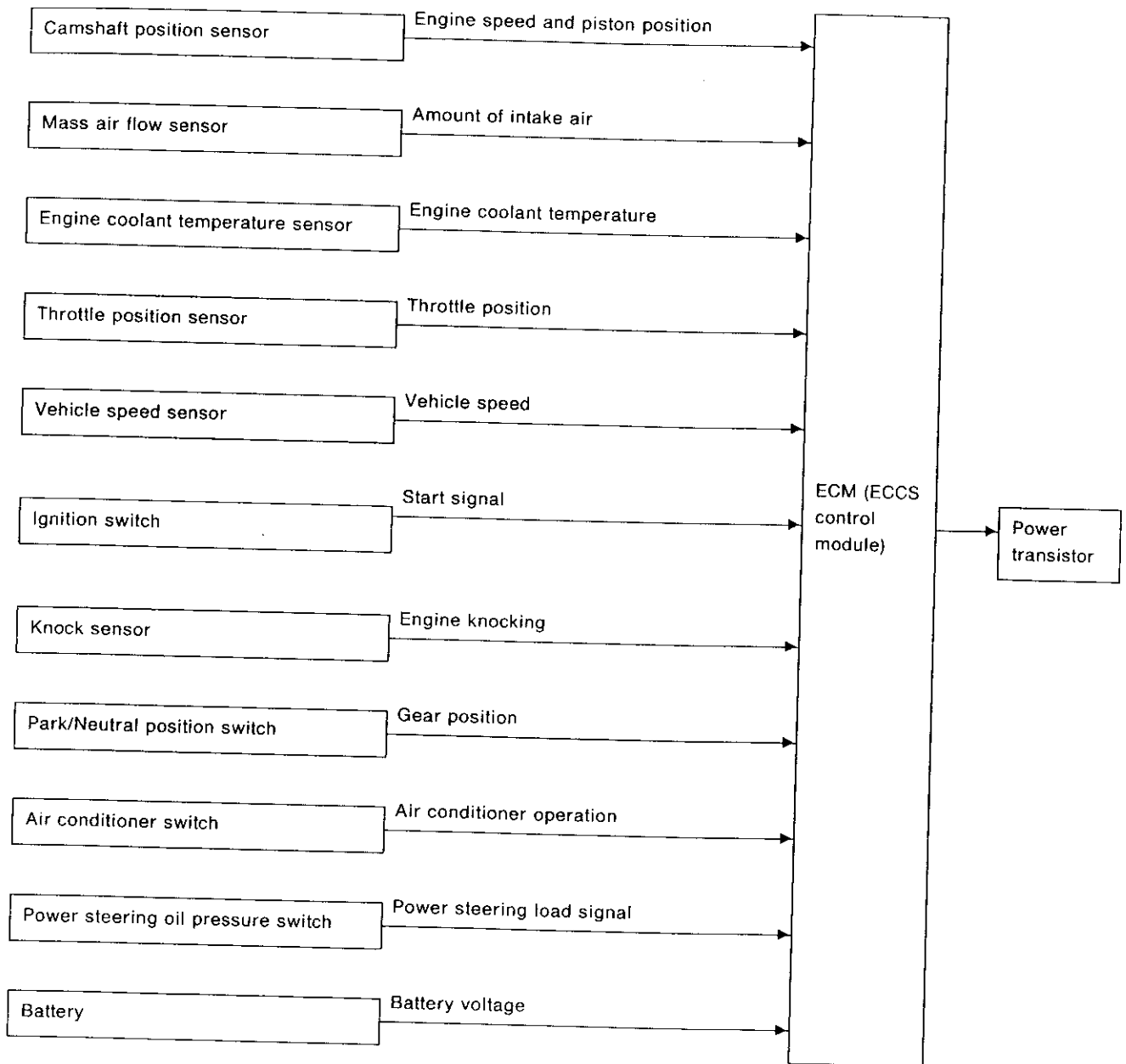



# ENGINE AND EMISSION CONTROL SYSTEM DESCRIPTION

## Electronic Ignition (EI) System (Cont'd)

### SYSTEM DESCRIPTION

The ignition timing is controlled by the ECM in order to maintain the best air-fuel ratio for every running condition of the engine. The ignition timing data is stored in the ECM. This data forms the map shown below. The ECM detects information such as the injection pulse width and camshaft position sensor signal which varies every moment. Then responding to this information, ignition signals

are transmitted to the power transistor.  
e.g. N: 1,800 rpm, Tp: 1.50 msec  
A °BTDC

In addition to this,

- 1) At starting
- 2) During warm-up
- 3) At idle
- 4) At low battery voltage

the ignition timing is revised by the ECM according to the other data stored in the ECM.

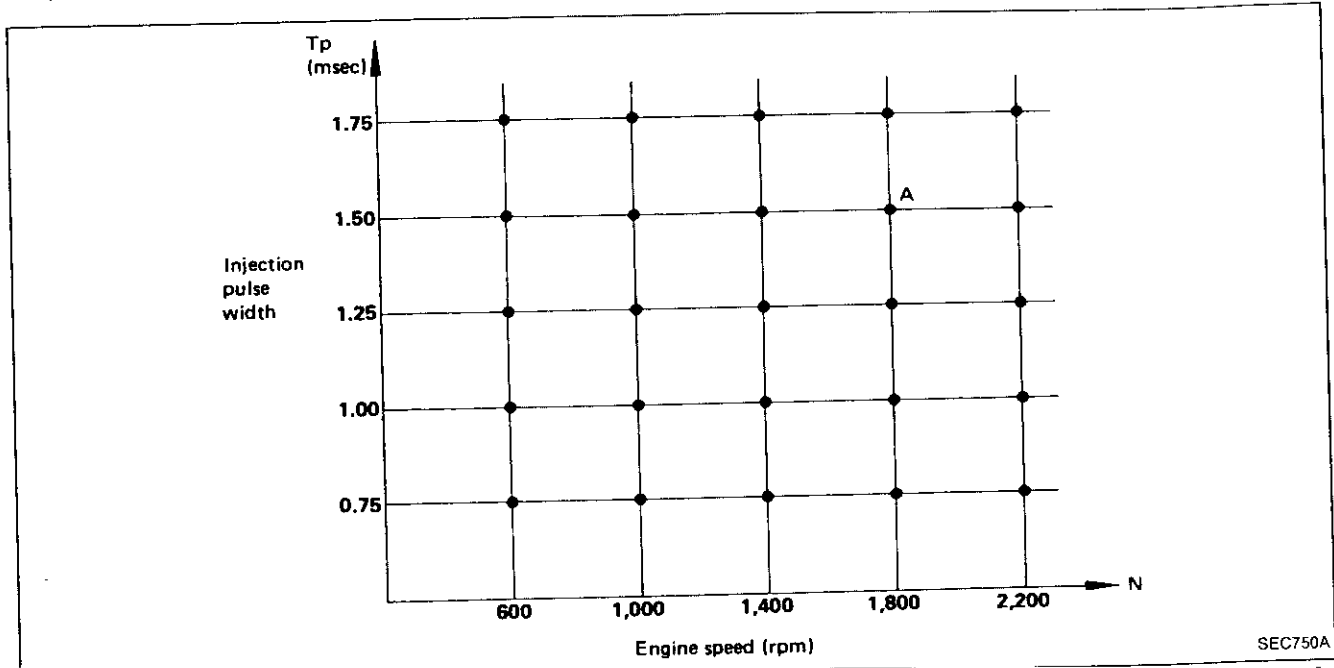

The retard system, actuated by the knock sensor, is designed only for emergencies. The basic ignition timing is pre-programmed within the anti-knocking zone, if recommended fuel is used under dry conditions. Consequently, the retard system does not operate under normal driving conditions.

However, if engine knocking occurs, the knock sensor monitors the condition and the signal is transmitted to the ECM (ECCS control module). After receiving it, the ECM retards the ignition timing to eliminate the knocking condition.

GI

MA

EM

LC

EC

FE

CL

MT

AT

PD

FA

RA

BR

ST

RS

BT

HA

EL

IDX

# ENGINE AND EMISSION CONTROL SYSTEM DESCRIPTION

## Idle Air Control (IAC) System

### INPUT/OUTPUT SIGNAL LINE

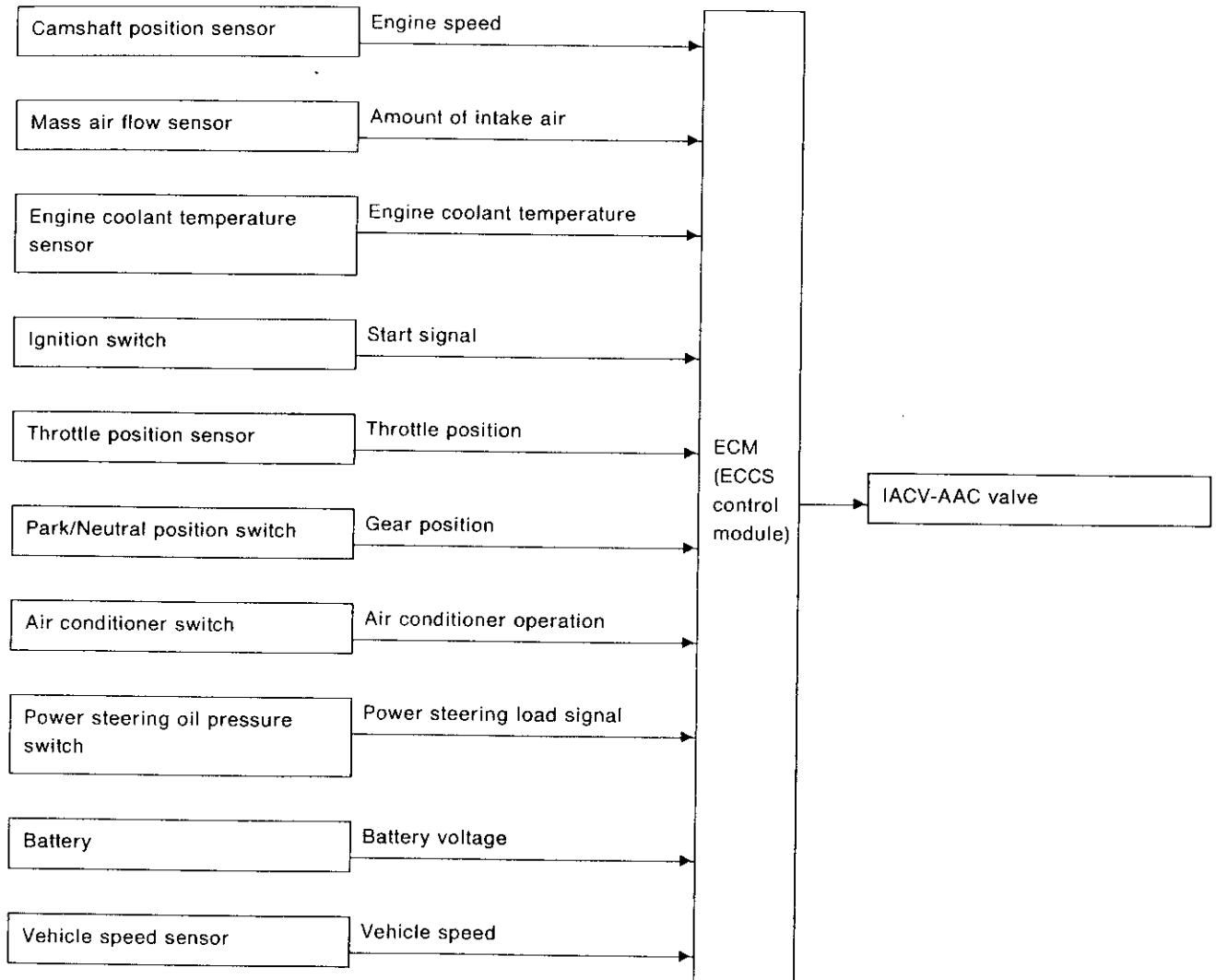

### SYSTEM DESCRIPTION

This system automatically controls engine idle speed to a specified level. Idle speed is controlled through fine adjustment of the amount of air which by-passes the throttle valve via the IACV-AAC valve. The IACV-AAC valve repeats ON/OFF operation according to the signal sent from the ECM. The camshaft position sensor detects the actual engine speed and sends a signal to the ECM.

The ECM then controls the ON/OFF time of the IACV-AAC valve so that engine speed coincides with the target value memorized in the ECM. The target engine speed is the lowest speed at which the engine can operate steadily. The optimum value stored in the ECM is determined by taking into consideration various engine conditions, such as noise and vibration transmitted to the vehicle interior, fuel consumption, and engine load.

# ENGINE AND EMISSION CONTROL SYSTEM DESCRIPTION

## Fuel Pump Control

### INPUT/OUTPUT SIGNAL LINE

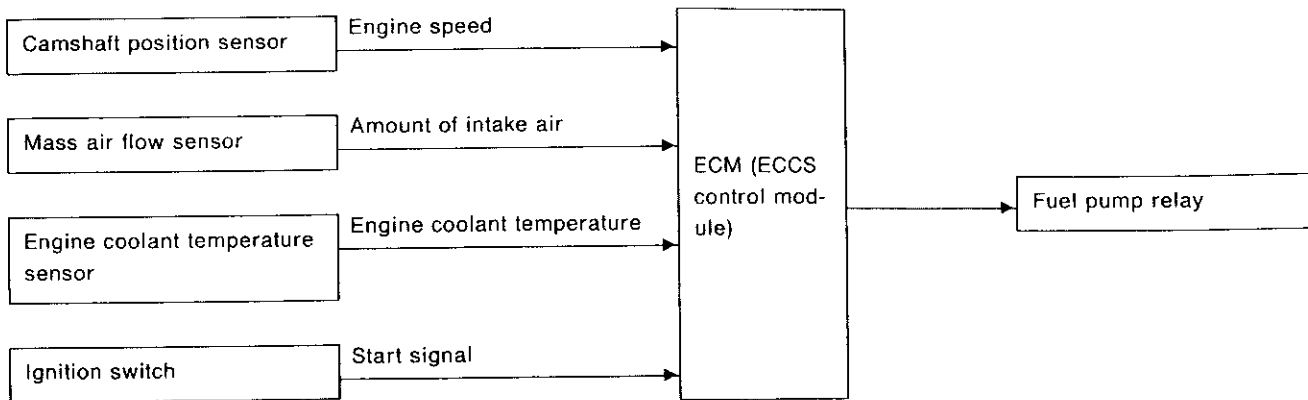

### SYSTEM DESCRIPTION

#### Fuel pump ON-OFF control

The ECM activates the fuel pump for several seconds after the ignition switch is turned on to improve engine start-up. If the ECM receives a 1° signal from the camshaft position sensor, it knows that the engine is rotating, and causes the pump to activate. If the 1° signal is not received when the ignition switch is on, the engine stalls. The ECM stops pump operation and prevents the battery from discharging, thereby improving safety. The ECM does not directly drive the fuel pump. It controls the ON/OFF fuel pump relay, which in turn controls the fuel pump.

Condition	Fuel pump operation
Ignition switch is turned to ON.	Operates for 1 second
Engine running and cranking	Operates
When engine is stopped	Stops in 1 second
Except as shown above	Stops

GI  
WA  
EM  
LC  
**EC**  
FE  
CL  
VT  
AT  
PD  
FA  
RA  
BR  
ST  
RS  
BT  
FA

EL  
IDY

# ENGINE AND EMISSION CONTROL SYSTEM DESCRIPTION

## Exhaust Gas Recirculation (EGR) and Canister Control System

### INPUT/OUTPUT SIGNAL LINE

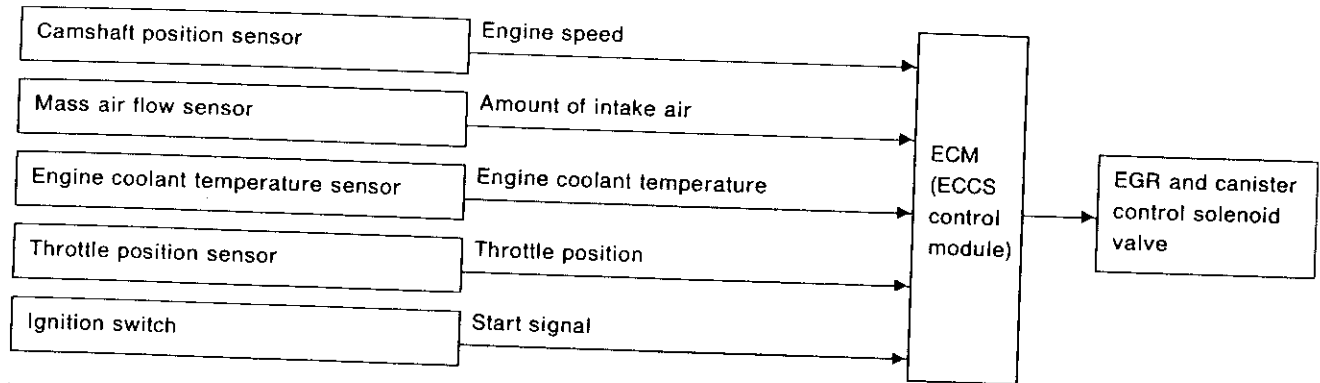

### SYSTEM DESCRIPTION

This system cuts and controls vacuum applied to EGR valve and canister to suit engine operating conditions. This cut-and-control operation is accomplished through the ECM and the EGR & canister control solenoid valve. When the ECM detects any of the following conditions, current flows through the solenoid valve. This causes the port vacuum to be discharged into the atmosphere. The EGR valve and canister remain closed.

- 1) Low engine coolant temperature
- 2) Engine starting
- 3) High-speed engine operation
- 4) Engine idling
- 5) Excessively high engine coolant temperature
- 6) Mass air flow sensor malfunction

## Air Conditioner Cut Control

### INPUT/OUTPUT SIGNAL LINE

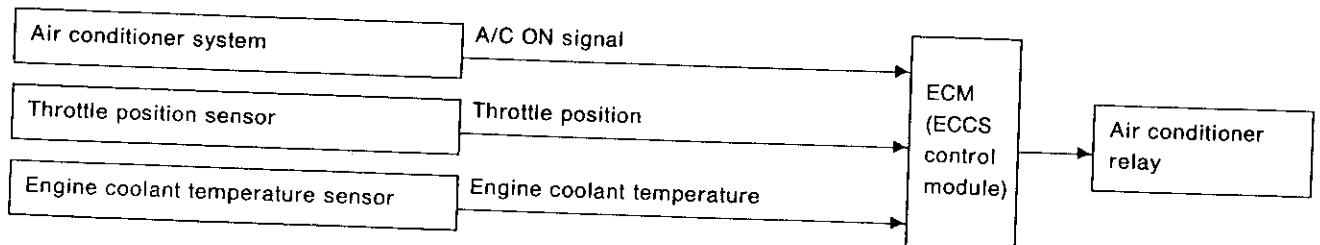

### SYSTEM DESCRIPTION

When the accelerator pedal is fully depressed, or engine coolant temperature is extremely high, the air conditioner is turned off for a few seconds.

This system improves acceleration when the air conditioner is used.

# ENGINE AND EMISSION CONTROL SYSTEM DESCRIPTION

## Valve Timing Control (VTC)

### INPUT/OUTPUT SIGNAL LINE

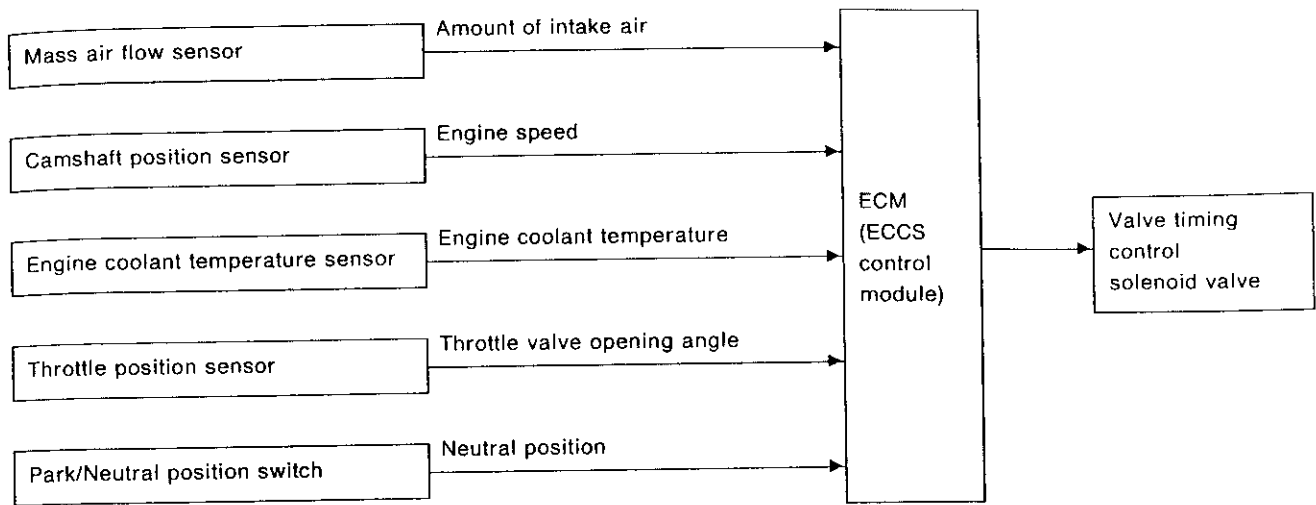

### SYSTEM DESCRIPTION

The valve timing control system is utilized to increase engine performance. Intake valve opening and closing time is controlled, according to the engine operating conditions, by the ECM.

Engine coolant temperature signals, engine speed, amount of intake air, throttle position, vehicle speed and gear position are used to determine intake valve timing.

The intake camshaft pulley position is regulated by oil pressure, which is controlled by the valve timing control solenoid valve.

GI

WA

EM

LC

EC

FE

CL

MT

AT

PD

EA

RA

BR

ST

RS

BT

HA

EL

DX

# ENGINE AND EMISSION CONTROL SYSTEM DESCRIPTION

## Valve Timing Control (VTC) (Cont'd)

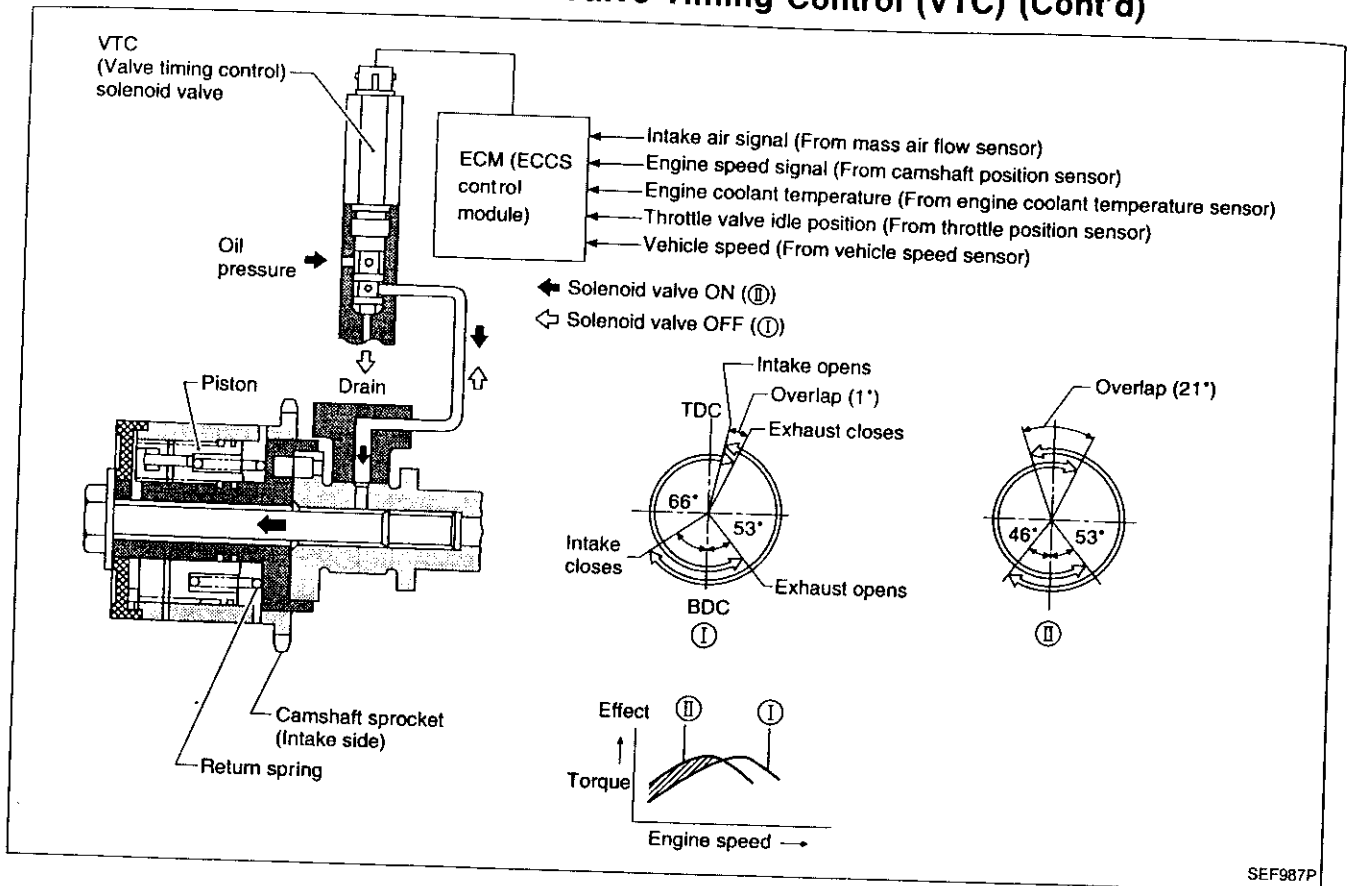

SEF987P

### OPERATION

Engine operating condition	Valve timing control solenoid valve	Intake valve opening and closing time	Valve overlap	Engine torque curve
<ul style="list-style-type: none"> <li>Vehicle is running.</li> <li>Engine coolant temperature is 50°C (122°F) or more.</li> <li>Engine speed is between 1,050 rpm and 5,700 rpm.</li> </ul>	ON	Advance	Increased	II
<ul style="list-style-type: none"> <li>Engine load is high.</li> <li>Engine speed is 1,050 rpm or less.</li> </ul>	OFF	Normal	Normal	I
Those other than above	OFF	Normal	Normal	I

# ENGINE AND EMISSION CONTROL SYSTEM DESCRIPTION

## Heated Oxygen Sensor (HO2S) Heater Control

### INPUT/OUTPUT SIGNAL LINE

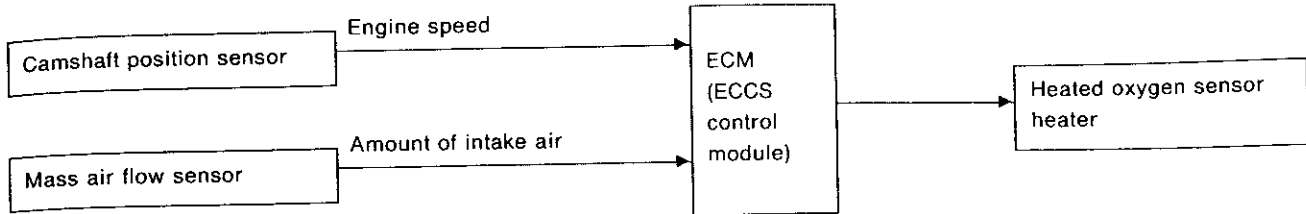

The ECM performs ON/OFF control of the heated oxygen sensor heater corresponding to the engine speed and engine load.

### OPERATION

Engine operating condition	Heated oxygen sensor heater
Engine speed is more than 4,000 rpm.	OFF
Heavy load	OFF
Except above	ON

## Cooling Fan Control

### INPUT/OUTPUT SIGNAL LINE

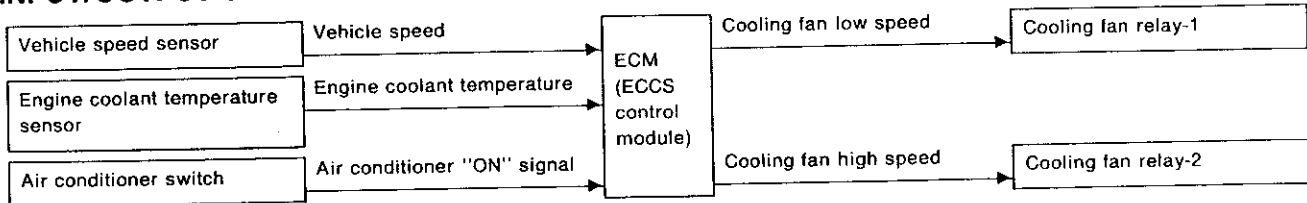

The ECM controls the cooling fan corresponding to vehicle speed, engine coolant temperature

and air conditioner ON signal. The control system has a 2-step control [HIGH/LOW/OFF].

### OPERATION

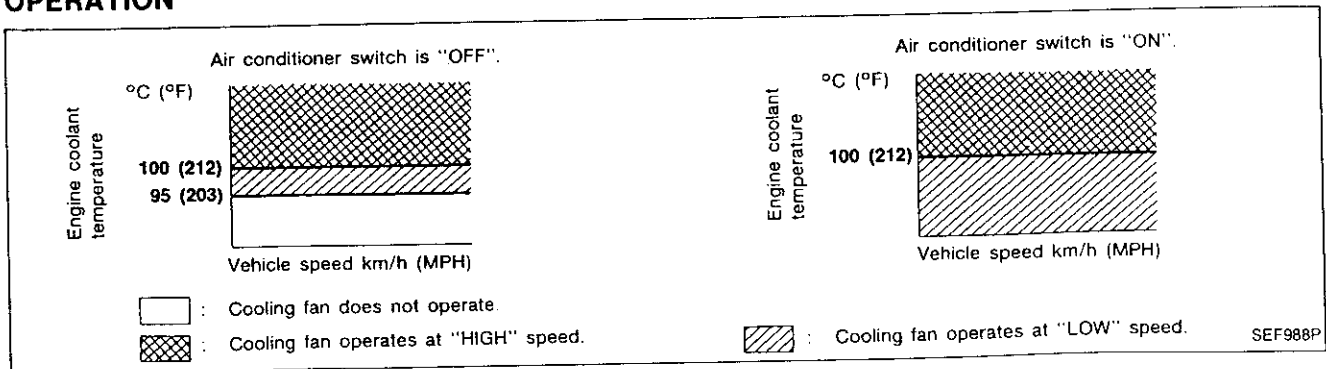

The cooling fan operates at HIGH speed if diagnostic test mode II (self-diagnostic results) for engine coolant temperature sensor is "NG".

## ENGINE AND EMISSION CONTROL SYSTEM DESCRIPTION

### Boost Pressure Control

#### INPUT/OUTPUT SIGNAL LINE

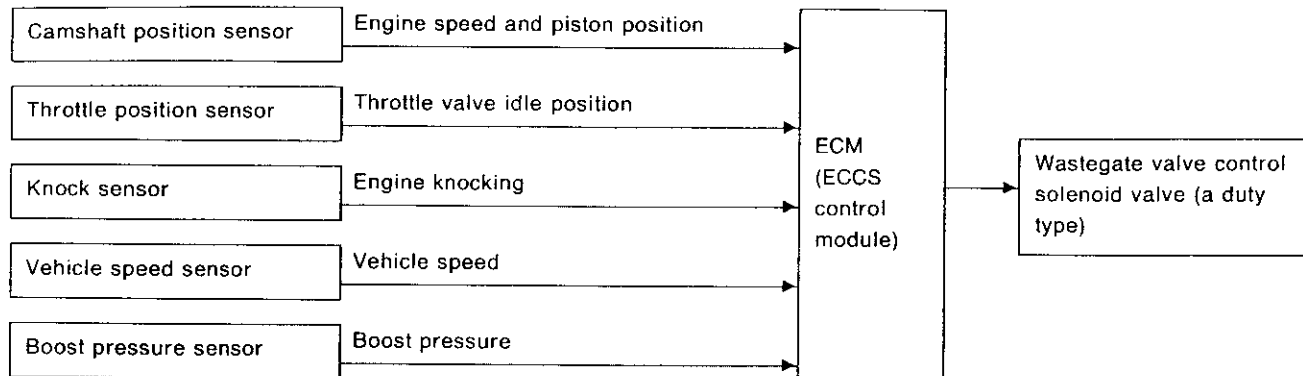

#### SYSTEM DESCRIPTION

The output signal maps of the ECM are selected according to fuel octane rating, gear position (M/T model) and vehicle speed (A/T model). The wastegate valve control solenoid valve

changes the source vacuum which activates the actuator. This results in a proportional boost pressure to the acceleration. Knock signs are used to determine fuel octane rating.

#### OPERATION

Fuel octane rating	Gear position or vehicle speed	Boost pressure control map
Premium	<ul style="list-style-type: none"> <li>● 1, 2 and 3 speed gears (M/T model)</li> <li>● Less than 46 km/h (29 MPH) (A/T model)</li> </ul>	A slow response type
	<ul style="list-style-type: none"> <li>● 4 and 5 speed gears (M/T model)</li> <li>● More than 46 km/h (29 MPH) (A/T model)</li> </ul>	A quick response type
Lower than the above	Any	Fixed



# ENGINE AND EMISSION CONTROL SYSTEM DESCRIPTION

## Fail-safe System

### CPU MALFUNCTION

#### Input/output signal line

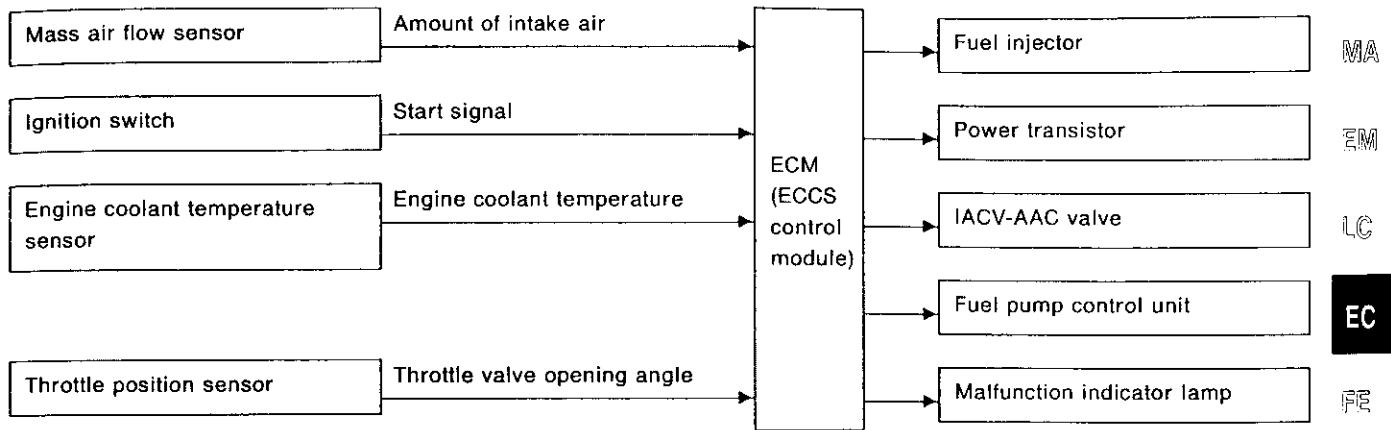

### Outline

The fail-safe system makes engine starting possible if there is something malfunctioning in the ECM's CPU circuit.

In former models, engine starting was difficult under the previously mentioned conditions. But with the provisions in this fail-safe system, it is possible to start the engine.

### Fail-safe system activating condition when ECM is malfunctioning

The fail-safe mode operates when the computing function of the ECM is judged to be malfunctioning.

When the fail-safe system activates, i.e. if a malfunction condition is detected in the CPU of the ECM, the MALFUNCTION INDICATOR LAMP on the instrument panel lights to warn the driver.

### Engine control with fail-safe system, operates when ECM is malfunctioning

When the fail-safe system is operating, fuel injection, ignition timing, fuel pump operation, engine idle speed, and so on are controlled under certain limitations.

### Operation (Mass air flow sensor malfunction)

Engine condition	Starter switch	Fail-safe system	Fail-safe functioning
Stopped	ANY	Does not operate.	—
Cranking	ON	Operates.	Engine will be started by a pre-determined injection pulse on ECM.
Running	OFF		Engine speed will not rise above 2,400 rpm

### Cancellation of fail-safe system when ECM is malfunctioning

Activation of the fail-safe system is canceled each time the ignition switch is turned OFF. The system is reactivated if all of the activating conditions are satisfied after turning the ignition switch from OFF to ON.

### MASS AIR FLOW SENSOR MALFUNCTION

If the mass air flow sensor output voltage is below the specified value, the ECM senses a mass air flow sensor malfunction. In the case of a malfunction, the throttle position sensor substitutes for the mass air flow sensor.

Although the mass air flow sensor is malfunctioning, it is possible to start the engine and drive the vehicle. But engine speed will not rise more than 2,400 rpm in order to inform the driver of fail-safe system operation while driving.

## ENGINE AND EMISSION CONTROL SYSTEM DESCRIPTION

### Fail-safe System (Cont'd)

#### ENGINE COOLANT TEMPERATURE SENSOR MALFUNCTION

When engine coolant temperature sensor output voltage is below or above the specified value, engine coolant temperature is fixed at the preset value as follows:

Engine condition	Engine coolant temperature preset value °C (°F)
Start	20 (68)
Running	80 (176)

#### THROTTLE POSITION SENSOR MALFUNCTION

##### Description

When the output signal of throttle position sensor is abnormal the ECM judges it as a malfunctioning of throttle position sensor.

The ECM do not use the throttle position sensor signal.

#### KNOCK SENSOR MALFUNCTION

When ECM judged to be malfunctioning, ignition timing is controlled numerical value for regular gasoline.

#### START SIGNAL FOR MALFUNCTION

If the ECM always receives a start signal, the ECM will judge the start signal "OFF" when engine speed is above 1,000 rpm to prevent extra enrichment.

After the engine speed is below 200 rpm, start-up enrichment will be allowed until the engine speed reaches 1,000 rpm.

#### BOOST PRESSURE SENSOR MALFUNCTION

When ECM judged to be malfunctioning, the duty of wastegate valve control solenoid valve is fixed at 20%.

# ENGINE AND EMISSION CONTROL SYSTEM DESCRIPTION

## Direct Ignition System

### CHECKING IDLE SPEED AND IGNITION TIMING

#### Idle speed

1. Disconnect check connector for voltage type tachometer.
2. Connect tachometer using a suitable tool.

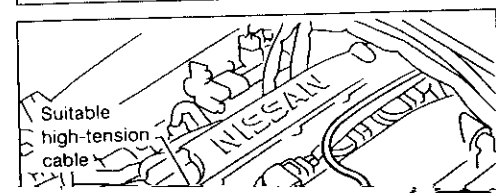
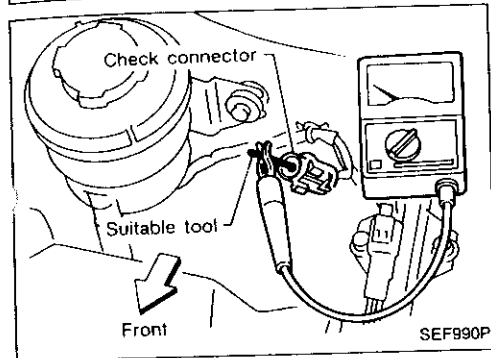
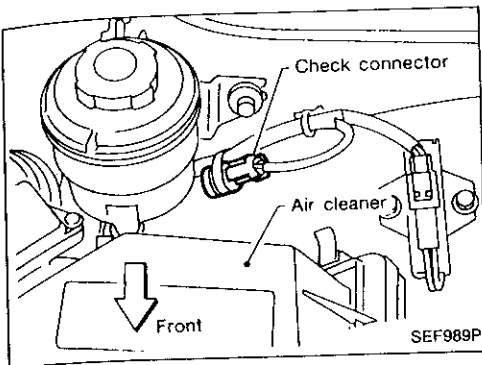

#### Ignition timing

##### ● Method A (Without SST)

1. Remove No. 1 ignition coil.
2. Connect No. 1 ignition coil and No.1 spark plug with a suitable high-tension wire as shown, and attach timing light. For the above procedures, enlarge the end of a suit-

GI

MA

EM

LC

EC

FE

CL

MT

AT

PD

## ENGINE AND EMISSION CONTROL SYSTEM DESCRIPTION

### Direct Ignition System (Cont'd)

- **Method B (Without SST)**

Clamp wire as shown.

This wire is provided at the rear end of the engine.

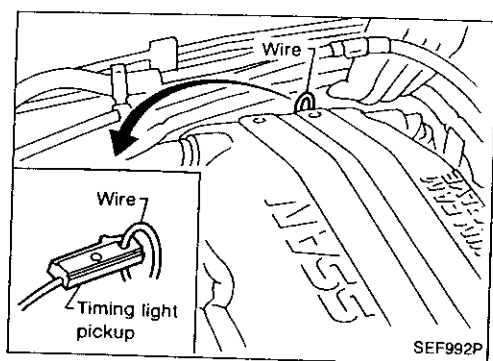

# IDLE SPEED/IGNITION TIMING/IDLE MIXTURE RATIO INSPECTION

## PREPARATION

1. Make sure that the following parts are in good order.

- Battery
- Ignition system
- Engine oil and coolant levels
- Fuses
- ECM harness connector
- Vacuum hoses
- Air intake system (Oil filler cap, oil level gauge, etc.)
- Fuel pressure
- Engine compression
- EGR valve operation
- Throttle valve

2. On air conditioner equipped models, checks should be carried out while the air conditioner is "OFF".

3. When checking idle speed, ignition timing and mixture ratio of A/T models, shift lever to "N" position.

4. When measuring "CO" percentage, insert probe more than 40 cm (15.7 in) into tail pipe.

5. Turn off headlamps, heater blower, rear defogger.

6. Keep front wheels pointed straight ahead.

7. Make the check after the cooling fan has stopped.

## Overall inspection sequence

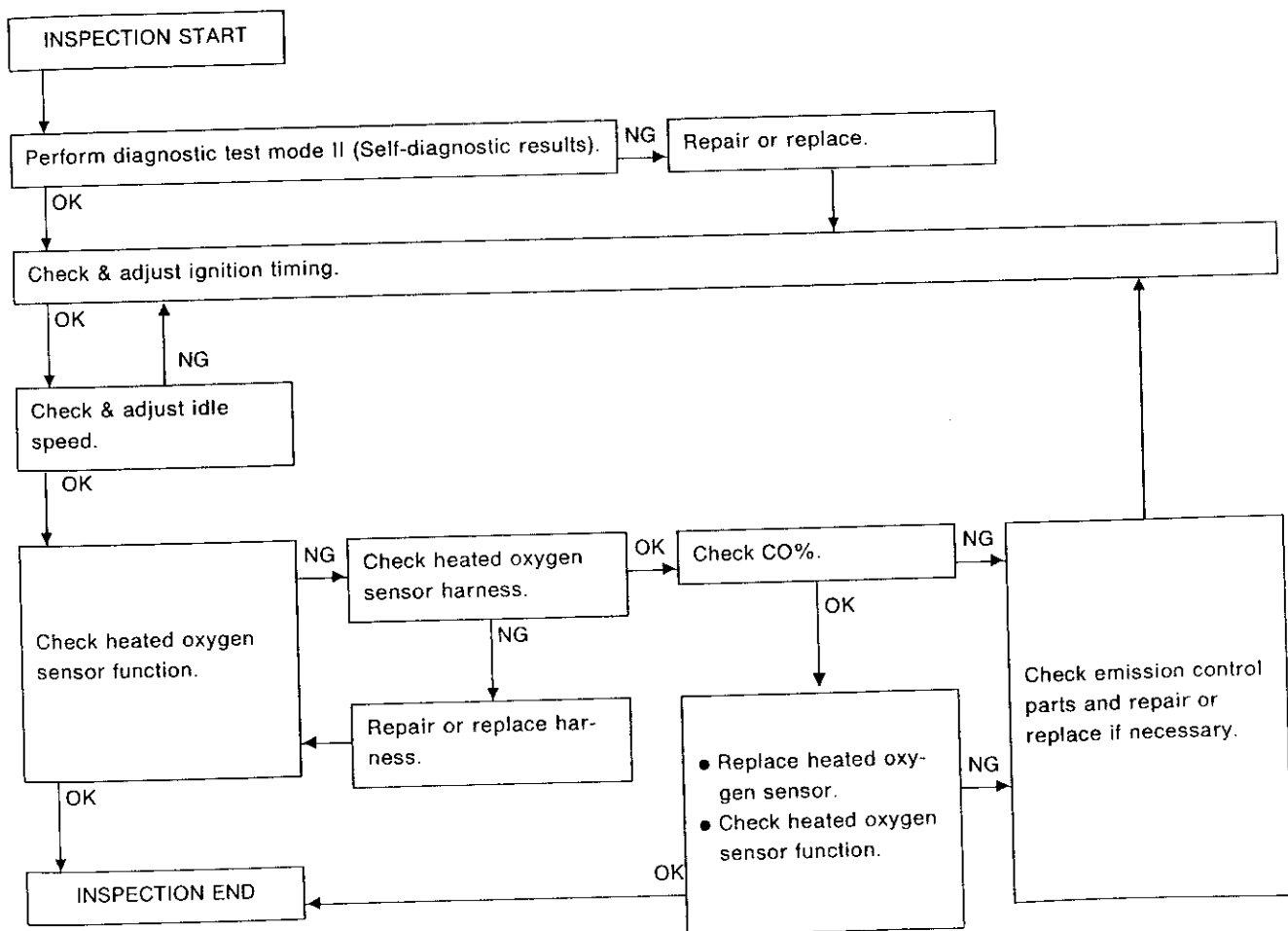

GI

MA

EM

LC

**EC**

FE

CL

MT

AT

PD

FA

RA

BR

ST

RS

BT

HA

EL

IDX

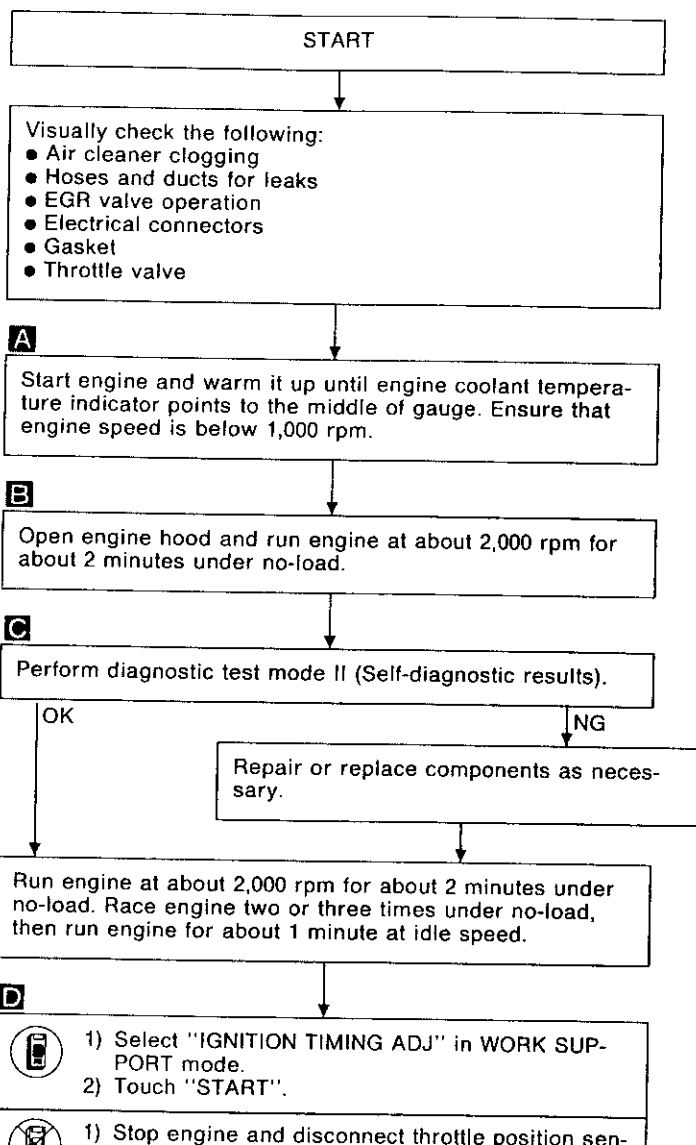
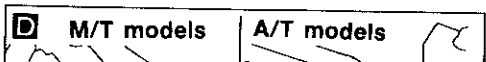
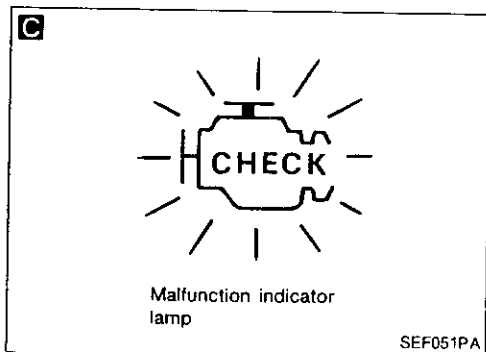
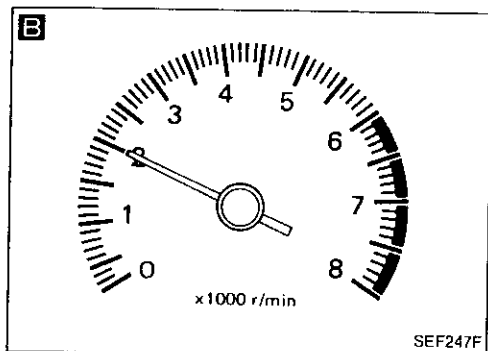
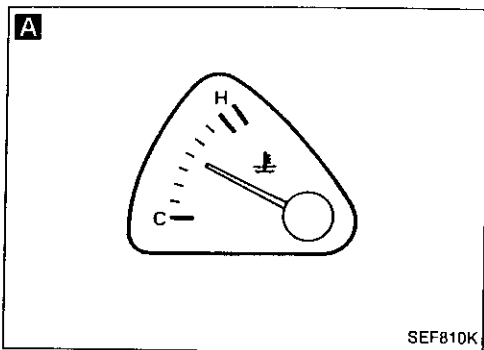

# IDLE SPEED/IGNITION TIMING/IDLE MIXTURE RATIO INSPECTION

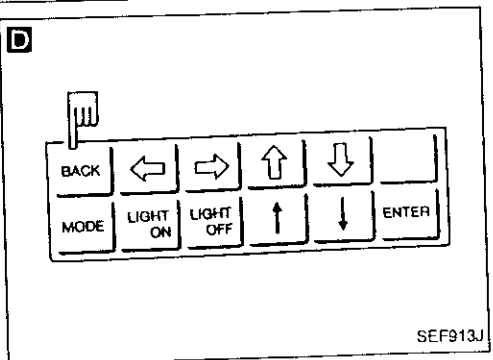
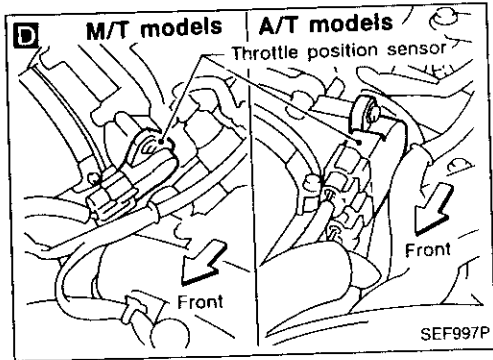
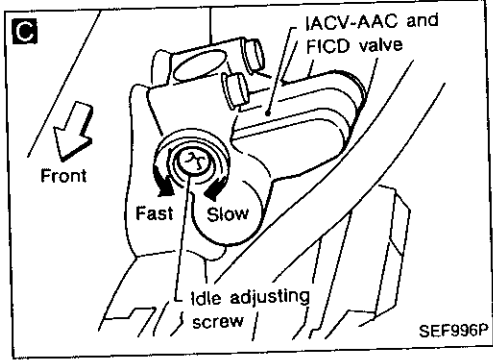
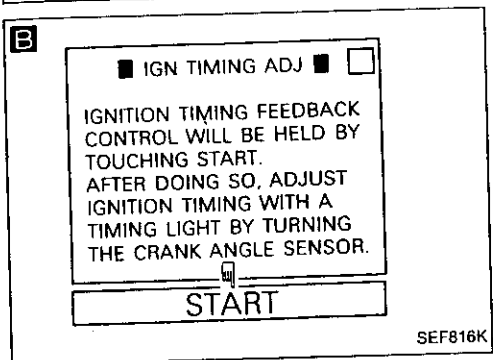
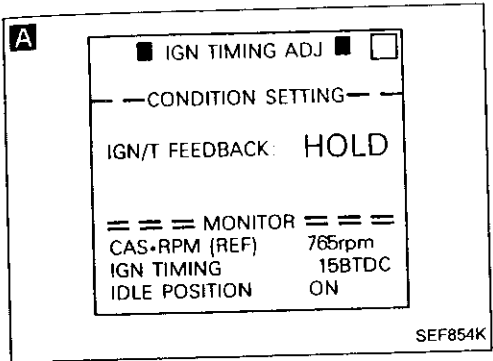

Ⓐ

Check idle speed.

Read idle speed in "IGN TIMING ADJ" in "WORK SUPPORT" mode.

OR

Check idle speed.

**800 ± 50 rpm (A/T in "N" position)**

OK → NG → Ⓔ

**B**

1) Select "IGN TIMING ADJ" in "WORK SUPPORT" mode.

2) Touch "START".

OR

Turn off engine and disconnect throttle position sensor harness connector. Then start engine.

Race engine two or three times to about 2,000 rpm under no-load. Then run engine at idle speed.

**C**

Adjust idle speed by turning idle speed adjusting screw.

**750 ± 50 rpm (A/T in "N" position)**

**D**

Touch "Back".

1) Stop engine and connect throttle position sensor harness connector.

2) Start engine.

Race engine two or three times to about 2,000 rpm under no-load. Then run engine at idle speed.

Check idle speed.

Read idle speed in "DATA MONITOR" mode with CONSULT.

OR

Check idle speed.

**800 ± 50 rpm (A/T in "N" position)**

OK → NG

Check AAC valve and replace if necessary.

**B** Check AAC valve harness and repair if necessary.

Check ECM function\* by substituting another known good ECM.

\*: ECM may be the cause of a problem, but this is rarely the case. Ⓑ

GI  
 MA  
 EM  
 LC  
**EC**  
 FE  
 CL  
 MT  
 AT  
 PD  
 FA  
 RA  
 BR  
 ST  
 RS  
 BT  
 HA  
 EL  
 IDX

# IDLE SPEED/IGNITION TIMING/IDLE MIXTURE RATIO INSPECTION

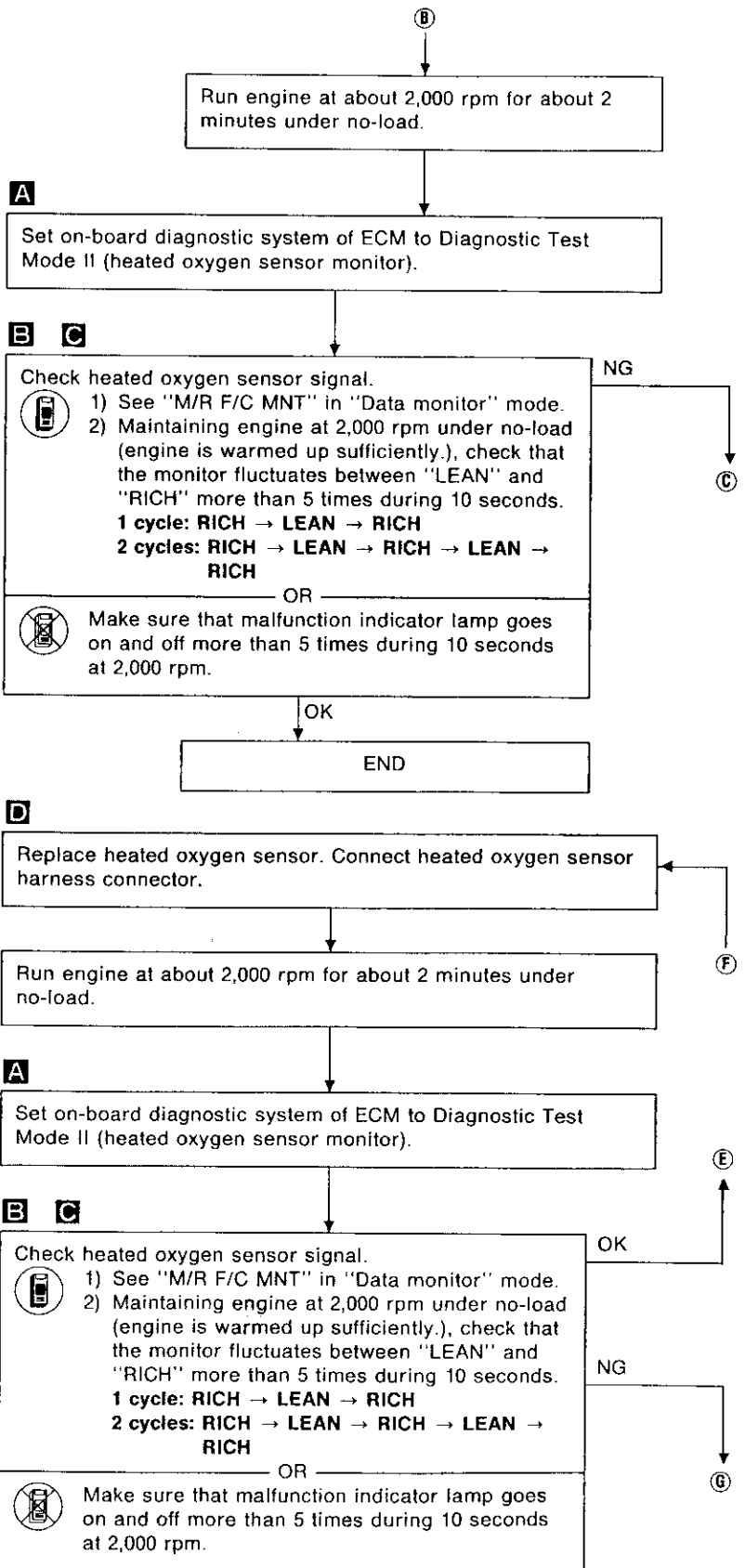
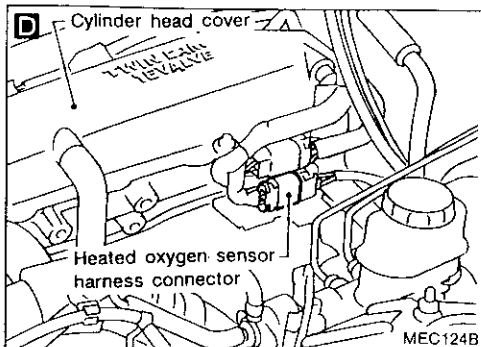
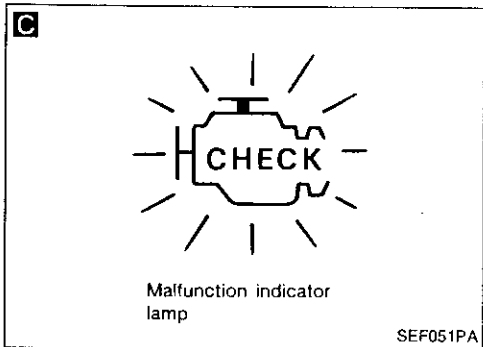
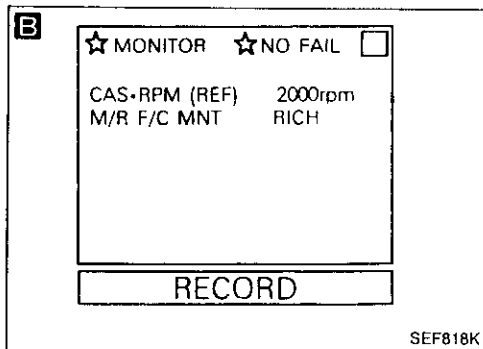
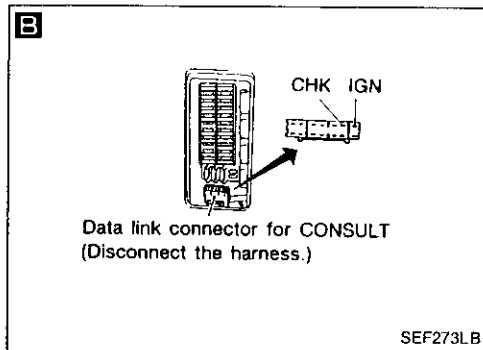
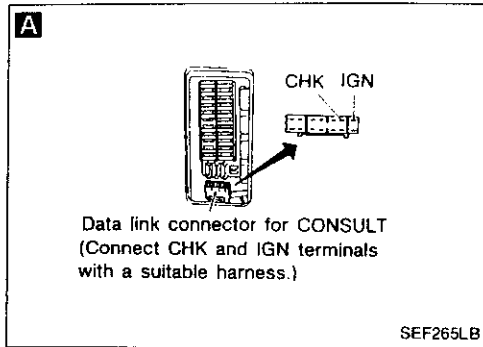



# IDLE SPEED/IGNITION TIMING/IDLE MIXTURE RATIO INSPECTION

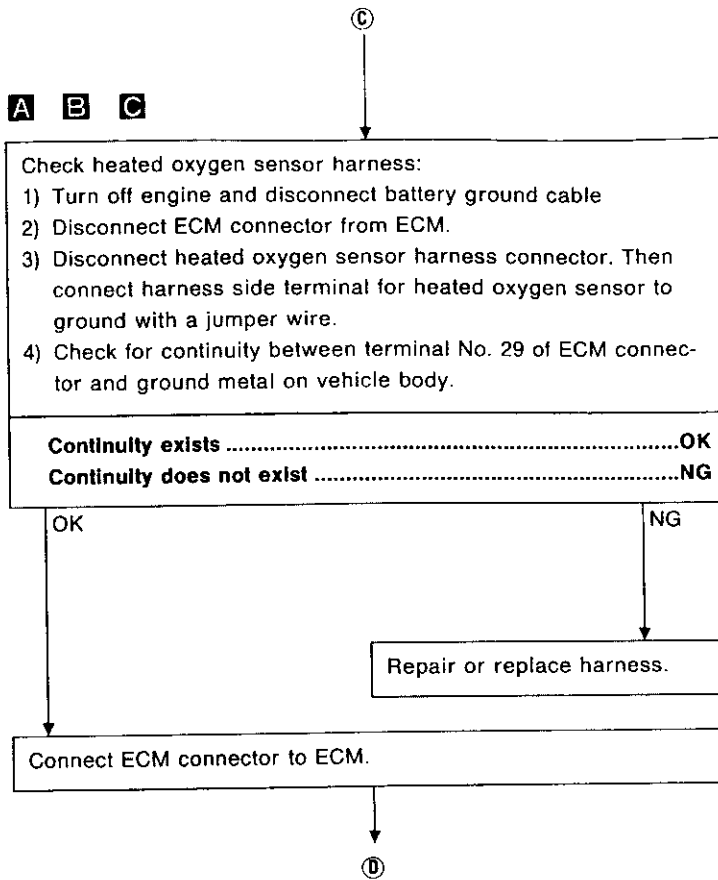
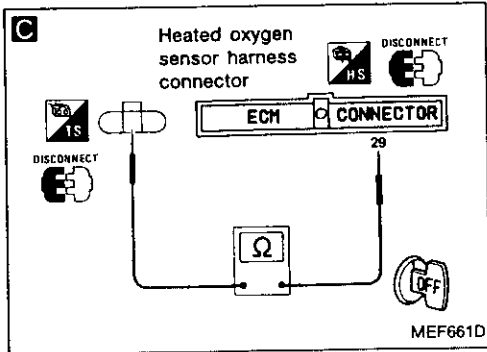
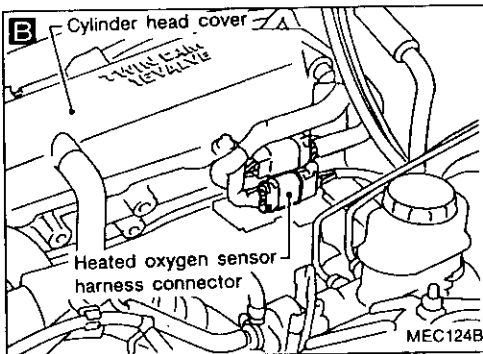
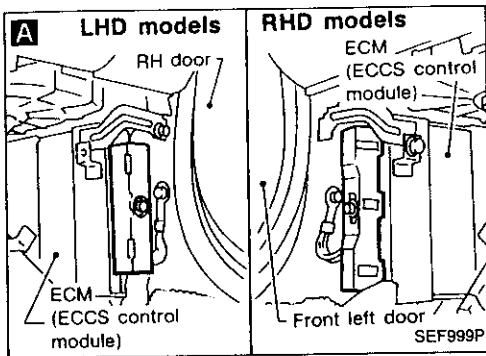

GI  
 MA  
 EM  
 LC  
**EC**  
 FE  
 CL  
 MT  
 AT  
 PD  
 FA  
 RA  
 BR  
 ST  
 RS  
 BT  
 HA  
 EL  
 IDX

# IDLE SPEED/IGNITION TIMING/IDLE MIXTURE RATIO INSPECTION

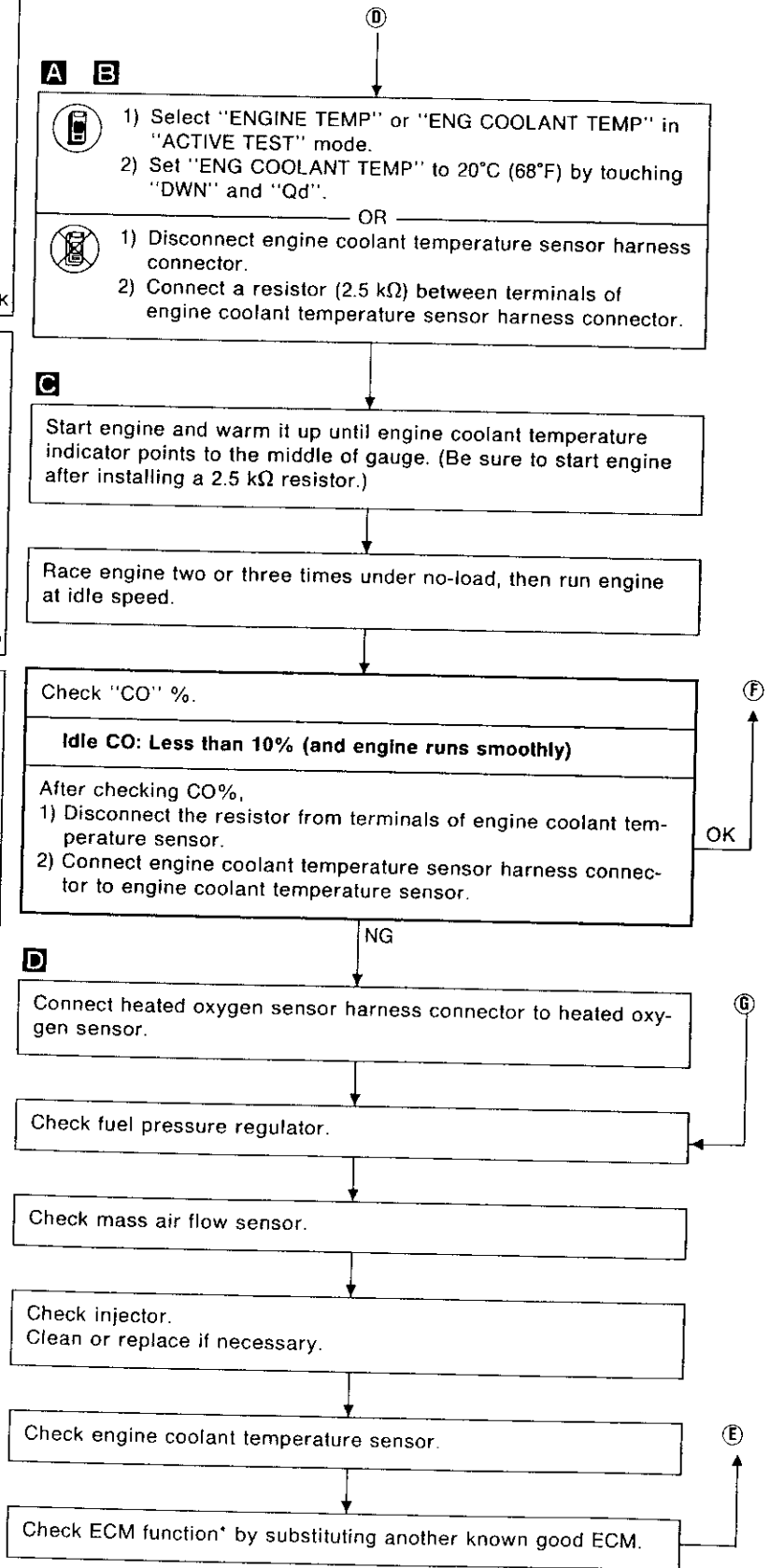
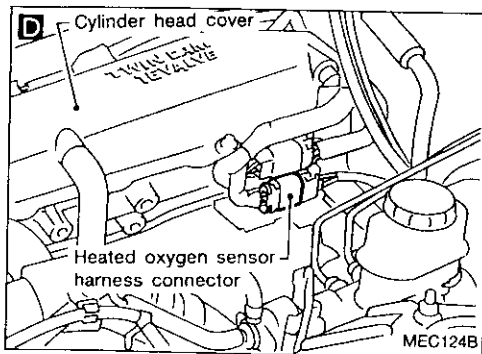
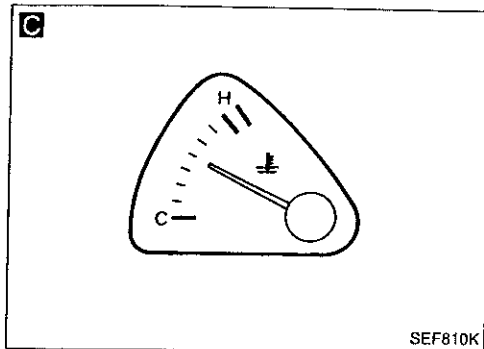
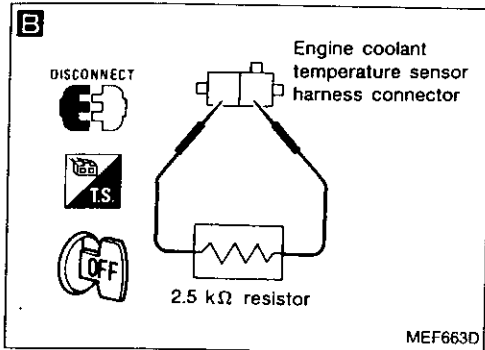
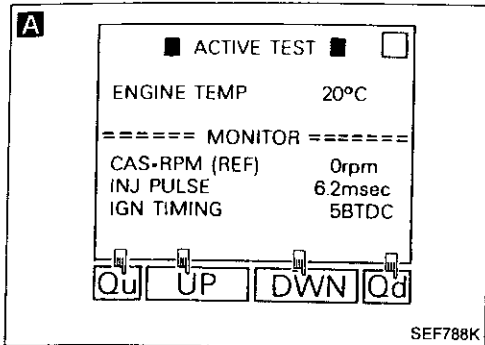

\*: ECM may be the cause of a problem, but this is rarely the case.

## TROUBLE DIAGNOSES

### Contents

How to Perform Trouble Diagnoses for Quick and Accurate Repair .....	EC- 43	
On-board Diagnostic System .....	EC- 48	GF
On-board Diagnostic System — Diagnostic Test Mode I .....	EC- 50	
On-board Diagnostic System — Diagnostic Test Mode II (Self-diagnostic results) .....	EC- 50	MA
On-board Diagnostic System — Diagnostic Test Mode II (Heated oxygen sensor monitor) .....	EC- 52	
Consult .....	EC- 53	EM
Diagnostic Procedure .....	EC- 61	
Basic Inspection .....	EC- 63	
How to Execute On-board Diagnostic System in Diagnostic Test Mode II .....	EC- 66	LC
Diagnostic Procedure 1 — Symptom — High Idling after Warm-up .....	EC- 70	
Diagnostic Procedure 2 — Symptom — Hunting .....	EC- 71	EC
Diagnostic Procedure 3 — Symptom — Unstable Idle .....	EC- 72	
Diagnostic Procedure 4 — Symptom — Hard to Start or Impossible to Start when the Engine is Cold .....	EC- 76	FE
Diagnostic Procedure 5 — Symptom — Hard to Start or Impossible to Start when the Engine is Hot .....	EC- 78	CL
Diagnostic Procedure 6 — Symptom — Hard to Start or Impossible to Start under Normal Conditions .....	EC- 80	
Diagnostic Procedure 7 — Symptom — Hesitation when the Engine is Hot .....	EC- 82	MT
Diagnostic Procedure 8 — Symptom — Hesitation when the Engine is Cold .....	EC- 83	
Diagnostic Procedure 9 — Symptom — Hesitation under Normal Conditions .....	EC- 84	AT
Diagnostic Procedure 10 — Symptom — Engine Stalls when Turning .....	EC- 85	
Diagnostic Procedure 11 — Symptom — Engine Stalls when the Engine is Hot .....	EC- 87	
Diagnostic Procedure 12 — Symptom — Engine Stalls when the Engine is Cold .....	EC- 89	PD
Diagnostic Procedure 13 — Symptom — Engine Stalls when Stepping on the Accelerator Momentarily .....	EC- 91	FA
Diagnostic Procedure 14 — Symptom — Engine Stalls after Decelerating .....	EC- 93	
Diagnostic Procedure 15 — Symptom — Engine Stalls when Accelerating or when Driving at Constant Speed .....	EC- 97	RA
Diagnostic Procedure 16 — Symptom — Engine Stalls when the Electrical Load is Heavy .....	EC- 99	
Diagnostic Procedure 17 — Symptom — Lack of Power and Stumble .....	EC-101	BR
Diagnostic Procedure 18 — Symptom — Knock .....	EC-102	
Diagnostic Procedure 19 — Symptom — Surge .....	EC-103	ST
Diagnostic Procedure 20 — Symptom — Backfire through the Intake .....	EC-104	
Diagnostic Procedure 21 — Symptom — Backfire through the Exhaust .....	EC-104	RS
Diagnostic Procedure 22 MAIN POWER SUPPLY AND GROUND CIRCUIT (Not self-diagnostic item) .....	EC-105	BT
Diagnostic Procedure 23 CAMSHAFT POSITION SENSOR (Diagnostic trouble code No. 11) .....	EC-109	
Diagnostic Procedure 24 MASS AIR FLOW SENSOR (Diagnostic trouble code No. 12) .....	EC-113	HA
Diagnostic Procedure 25 ENGINE COOLANT TEMPERATURE SENSOR (Diagnostic trouble code No. 13) .....	EC-116	EL
Diagnostic Procedure 26 IGNITION SIGNAL (Diagnostic trouble code No. 21) .....	EC-120	IDX
Diagnostic Procedure 27 BOOST PRESSURE SENSOR (Diagnostic trouble code No. 26) .....	EC-128	

## TROUBLE DIAGNOSES

### Contents (Cont'd)

<b>Diagnostic Procedure 28</b>	
KNOCK SENSOR (Diagnostic trouble code No. 34) .....	EC-132
<b>Diagnostic Procedure 29</b>	
THROTTLE POSITION SENSOR (Diagnostic trouble code No. 43) .....	EC-135
<b>Diagnostic Procedure 30</b>	
A/T CONTROL (Diagnostic trouble code No. 54) .....	EC-139
<b>Diagnostic Procedure 31</b>	
START SIGNAL (Not self-diagnostic item) .....	EC-142
<b>Diagnostic Procedure 32</b>	
VEHICLE SPEED SENSOR (Not self-diagnostic item) .....	EC-145
<b>Diagnostic Procedure 33</b>	
EGR AND CANISTER CONTROL (Not self-diagnostic item) .....	EC-148
<b>Diagnostic Procedure 34</b>	
HEATED OXYGEN SENSOR (Not self-diagnostic item) .....	EC-152
<b>Diagnostic Procedure 35</b>	
INJECTOR CIRCUIT (Not self-diagnostic item) .....	EC-156
<b>Diagnostic Procedure 36</b>	
FUEL PUMP (Not self-diagnostic item) .....	EC-159
<b>Diagnostic Procedure 37</b>	
WASTEGATE VALVE CONTROL (Not self-diagnostic item) .....	EC-163
<b>Diagnostic Procedure 38</b>	
VTC CONTROL (Not self-diagnostic item) .....	EC-166
<b>Diagnostic Procedure 39</b>	
IACV-AAC VALVE (Not self-diagnostic item) .....	EC-169
<b>Diagnostic Procedure 40</b>	
IACV-FICD SOLENOID VALVE (Not self-diagnostic item) .....	EC-172
<b>Diagnostic Procedure 41</b>	
COOLING FAN CONTROL (Not self-diagnostic item) .....	EC-176
<b>Diagnostic Procedure 42</b>	
POWER STEERING OIL PRESSURE SWITCH (Not self-diagnostic item) .....	EC-184
<b>Diagnostic Procedure 43</b>	
NEUTRAL POSITION SWITCH & A/T CONTROL UNIT (PARK/NEUTRAL POSITION SIGNAL) (Not self-diagnostic item) .....	EC-187
<b>Diagnostic Procedure 44</b>	
REAR WINDOW DEFOGGER SWITCH (Not self-diagnostic item) .....	EC-192
<b>Diagnostic Procedure 45</b>	
MALFUNCTION INDICATOR LAMP & DATA LINK CONNECTOR FOR CONSULT (Not self-diagnostic item) .....	EC-195
<b>Electrical Components Inspection</b> .....	EC-196
<b>Fast Idle Cam (FIC) Inspection and Adjustment</b> .....	EC-207

## TROUBLE DIAGNOSES

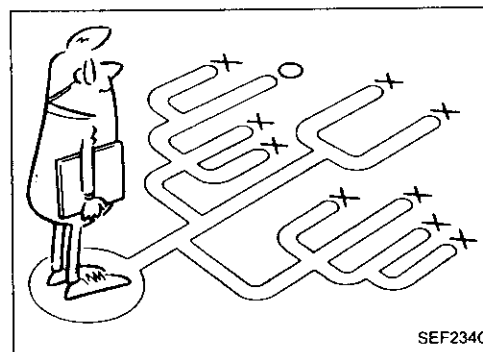
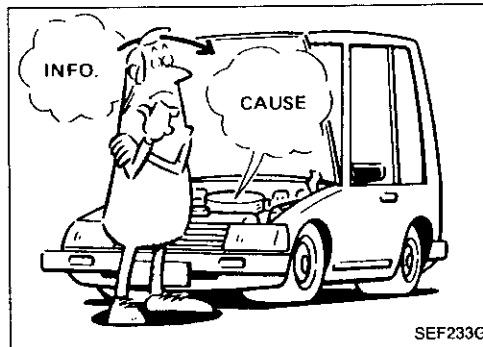
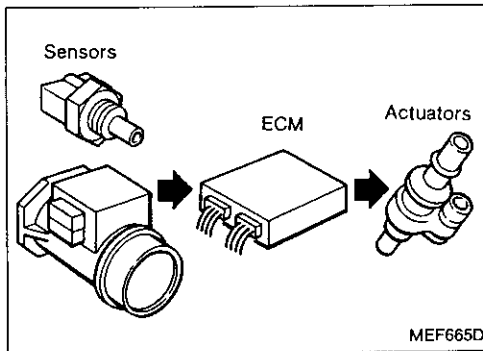

### How to Perform Trouble Diagnoses for Quick and Accurate Repair

#### INTRODUCTION

The engine has an ECM to control major systems such as fuel control, ignition control, idle air control system, etc. The ECM accepts input signals from sensors and instantly drives actuators. It is essential that both kinds of signals are proper and stable. At the same time, it is important that there are no conventional problems such as vacuum leaks, fouled spark plugs, or other problems with the engine.

It is much more difficult to diagnose a problem that occurs intermittently rather than continuously. Most intermittent problems are caused by poor electric connections or improper wiring. In this case, careful checking of suspected circuits may help prevent the replacement of good parts.

A visual check only may not find the cause of the problems, so a road test with a circuit tester connected to a suspected circuit should be performed.

Before checking, talk to customer about drivability complaint. The customer is a very good supplier of information on such problems, especially intermittent ones. Through interaction with the customer, find out what symptoms are present and under what conditions they occur.

Start your diagnosis by looking for "conventional" problems first. This is one of the best ways to troubleshoot drivability problems on an electronically controlled engine vehicle.

1. Verify the complaint.
2. Isolate the cause.
3. Repair
4. Recheck and be sure no new symptoms have been caused.

GI

WA

EM

LC

EC

FE

CL

WT

AT

PD

FA

RA

BR

ST

IS

BT

A

EL

FDX

# TROUBLE DIAGNOSES

## How to Perform Trouble Diagnoses for Quick and Accurate Repair (Cont'd)

### WORK FLOW

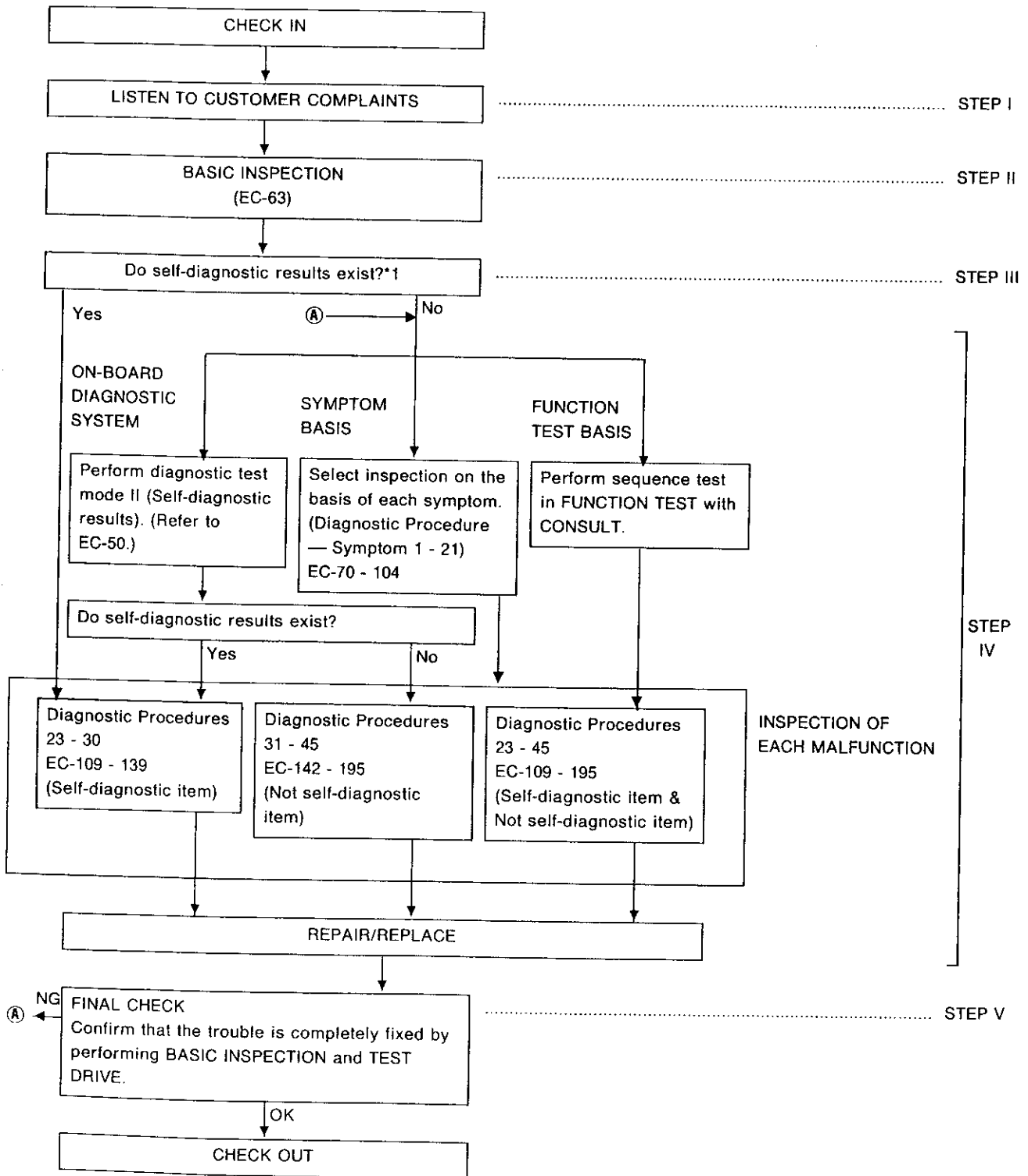

\*1: If the on-board diagnostic system cannot be performed, check main power supply and ground circuit. (See Diagnostic Procedure 22)

\*2: If the trouble is not duplicated, see INTERMITTENT PROBLEM SIMULATION (EC-47).

## TROUBLE DIAGNOSES

### How to Perform Trouble Diagnoses for Quick and Accurate Repair (Cont'd)

#### DESCRIPTION FOR WORK FLOW

STEP	DESCRIPTION	
STEP I	Identify the trouble using the "DIAGNOSTIC WORKSHEET" as shown on the next page.	GF
STEP II	Be sure to carry out the Basic Inspection, or the results of inspections thereafter may be misinterpreted.	MA
STEP III	Check the self-diagnostic results stored in the ECM of the failed vehicle.	EM
STEP IV	<p>Perform inspection often selecting from the following three tests according to the trouble observed.</p> <ol style="list-style-type: none"> <li>1. ON-BOARD DIAGNOSTIC SYSTEM Follow the self-diagnostic procedure for each item described in "How to Execute On-board Diagnostic System in Diagnostic Test Mode II". Non-self-diagnostic procedures described for some items will also provide results which are equal to the self-diagnostic results.</li> <li>2. SYMPTOM BASIS This inspection is of a simplified method. When performing inspection of a part, the corresponding system must be checked thoroughly by selecting the appropriate check item from Diagnostic Procedures 23 - 45.</li> <li>3. FUNCTION TEST BASIS (Sequence test) In this inspection, the CONSULT judges "OK" or "NG" on each system in place of a technician. When performing inspection of a part, the corresponding system must be checked thoroughly by selecting the appropriate check item from Diagnostic Procedures 23 - 45.</li> <li>4. Diagnostic Procedure <ul style="list-style-type: none"> <li>● This inspection program is prepared using the data obtained when disconnection of harness or connectors has occurred in the respective circuit.</li> <li>● Inspection of the "Not self-diagnostic item" does not actually start with the execution of diagnostic test mode II (self-diagnostic results). However, inspection is started by assuming that the diagnostic test mode II (self-diagnostic results) has already been performed.</li> <li>● When a system having the diagnostic test mode II (self-diagnostic results) function contains any circuit placed outside the range of this diagnostic test mode II (self-diagnostic results) function, it is arranged that the "Not self-diagnostic item" of such a system will be performed when the self-diagnostic result is OK. Example: CAMSHAFT POSITION SENSOR</li> </ul> </li> </ol>	EC FE CL MT AT PD FA
STEP V	<ol style="list-style-type: none"> <li>1. FINAL CHECK item is not described in the "Not self-diagnostic item". However, this FINAL CHECK must be performed without fail in order to ensure that the trouble has been repaired, and also that the unit disassembled in the course of the repair work has been reassembled correctly.</li> <li>2. If the same trouble phenomenon is observed again in the final check: Go back to STEP IV, and perform the inspection using a method which is different from the previous method.</li> <li>3. If the cause of the trouble is still unknown even after conducting step 2 above, check the circuit of each system for a short by using the voltage available at the "ECM INPUT/OUTPUT SIGNAL INSPECTION" terminal.</li> </ol>	RA BR ST RS BT HA EL DX





# TROUBLE DIAGNOSES

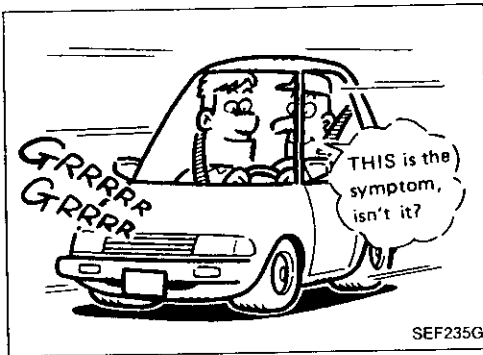

## and Accurate Repair (Cont'd)

### INTERMITTENT PROBLEM SIMULATION

In order to duplicate an intermittent problem, it is effective to create similar conditions for component parts, under which the problem might occur. Perform the activity listed under Service procedure and note the result.

	Variable factor	Influential part	Target condition	Service procedure
1	Mixture ratio	Pressure regulator	Made lean	Remove vacuum hose and apply vacuum.
			Made rich	Remove vacuum hose and apply pressure.
2	Ignition timing	Camshaft position sensor	Advanced	Rotate distributor counter clockwise.
			Retarded	Rotate distributor clockwise.
3	Mixture ratio feedback control	Heated oxygen sensor	Suspended	Disconnect heated oxygen sensor harness connector.
		ECM	Operation check	Perform diagnostic test mode II (Self-diagnostic results) at 2,000 rpm.
4	Idle speed	IACV-AAC valve	Raised	Turn idle adjusting screw counterclockwise.
			Lowered	Turn idle adjusting screw clockwise.
5	Electrical connection (Electric continuity)	Harness connectors and wires	Poor electrical connection or improper wiring	Tap or wiggle.
				Race engine rapidly. See if the torque reaction of the engine unit causes electric breaks.

GI  
 MA  
 EM  
 IC  
 EC  
 EE  
 CL  
 MT  
 AT  
 PD  
 EA

## TROUBLE DIAGNOSES

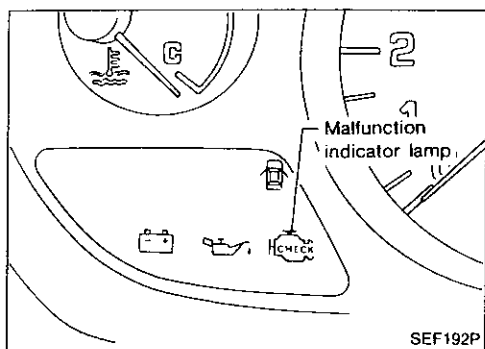



### On-board Diagnostic System

#### MALFUNCTION INDICATOR LAMP (MIL)

A malfunction indicator lamp has been adopted on all models.

#### ON-BOARD DIAGNOSTIC SYSTEM FUNCTION

Condition		Diagnostic Test Mode	
		Diagnostic Test Mode I	Diagnostic Test Mode II
Ignition switch in "ON" position	Engine stopped 	BULB CHECK	SELF-DIAGNOSTIC RESULTS
	Engine running 	MALFUNCTION WARNING	HEATED OXYGEN SENSOR MONITOR

# TROUBLE DIAGNOSES

## On-board Diagnostic System (Cont'd) HOW TO SWITCH MODES

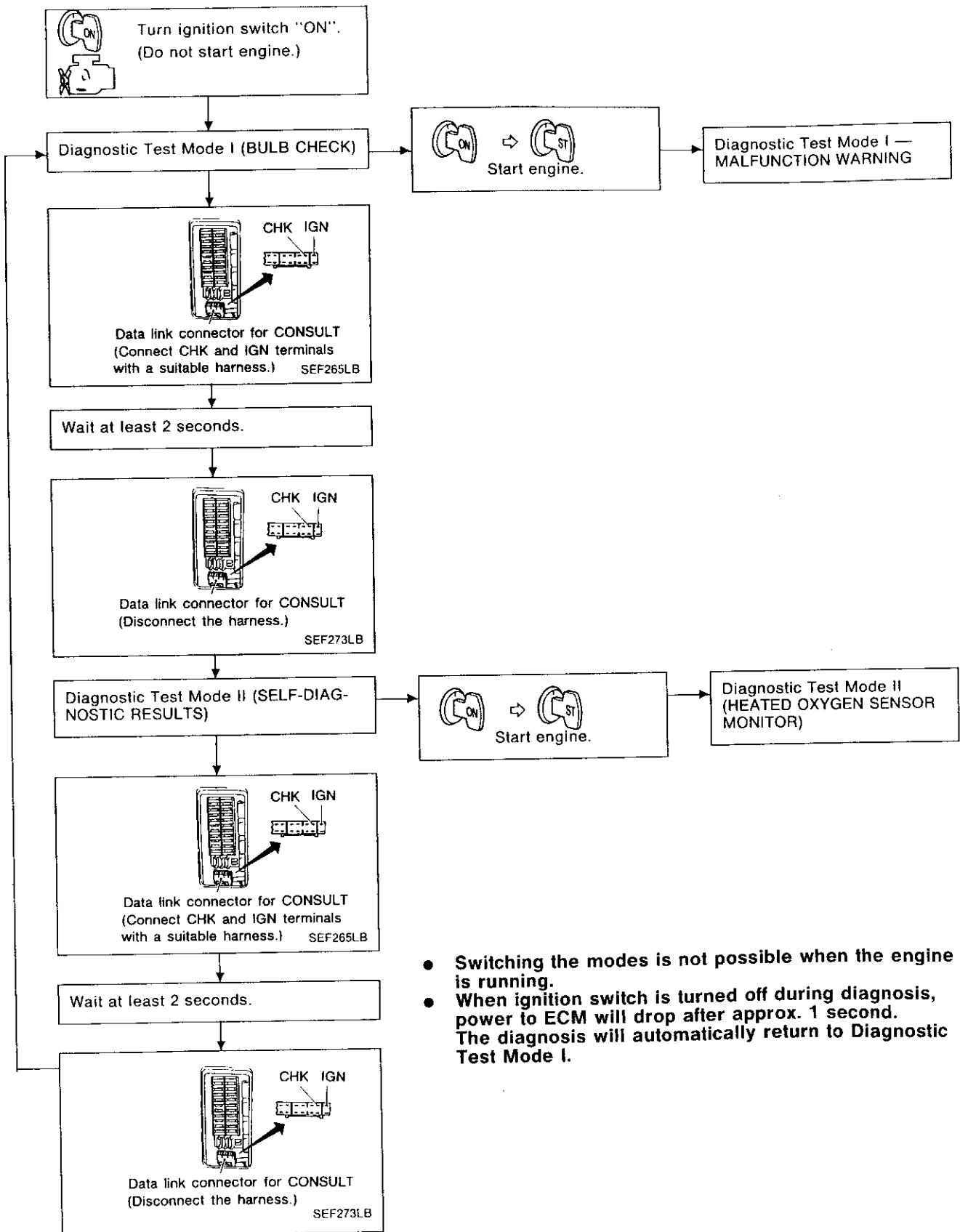

- Switching the modes is not possible when the engine is running.
- When ignition switch is turned off during diagnosis, power to ECM will drop after approx. 1 second. The diagnosis will automatically return to Diagnostic Test Mode I.

GI

MA

EM

LC

EC

FE

CL

MT

AT

PD

FA

RA

BR

ST

RS

BT

HA

EL

IDX

## TROUBLE DIAGNOSES

### On-board Diagnostic System — Diagnostic Test Mode I

#### DIAGNOSTIC TEST MODE I — BULB CHECK

In this mode, the MALFUNCTION INDICATOR LAMP in the instrument panel stays "ON".

If it remains "OFF", check the bulb in the MALFUNCTION INDICATOR LAMP.

#### DIAGNOSTIC TEST MODE I — MALFUNCTION WARNING

MALFUNCTION INDICATOR LAMP	Condition
ON	When the ECM's CPU or camshaft position sensor is malfunctioning.
OFF	OK

### On-board Diagnostic System — Diagnostic Test Mode II (Self-diagnostic results)

#### DESCRIPTION

In this mode, a diagnostic trouble code is indicated by the number of flashes from the MALFUNCTION INDICATOR LAMP (MIL) as shown below:

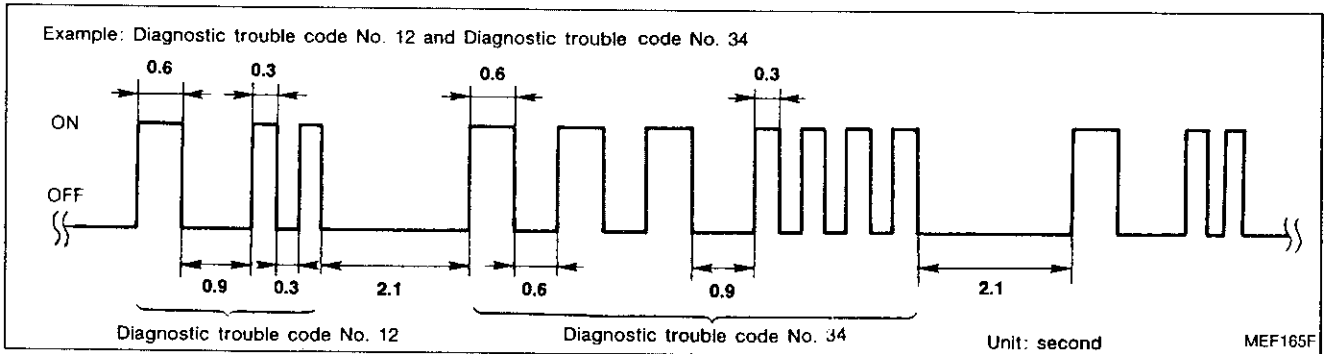

Long (0.6 second) blinking indicates the number of ten digits and short (0.3 second) blinking indicates the number of single digits.

For example, the MIL flashes for 0.6 seconds once and then it flashes for 0.3 seconds twice. This indicates the number "12" and refers to a malfunction in the mass air flow sensor. In this way, all the problems are classified by their diagnostic trouble code numbers.

The diagnostic results will remain in the ECM memory.

## TROUBLE DIAGNOSES

### On-board Diagnostic System — Diagnostic Test Mode II (Self-diagnostic results) (Cont'd)

#### Display diagnostic trouble code table

Diagnostic trouble code No.	Detected items
11*	Camshaft position sensor circuit
12	Mass air flow sensor circuit
13	Engine coolant temperature sensor circuit
21*	Ignition signal circuit
26	Boost pressure sensor circuit
34	Knock sensor circuit
43	Throttle position sensor circuit
54	Signal circuit from A/T control unit to ECM
55	No malfunction in the above circuits

\* Check items causing a malfunction of camshaft position sensor circuit first, if both "CAMSHAFT POSITION SENSOR (No. 11)" and "IGN SIGNAL-PRIMARY (No. 21)" are displayed one after the other.

Diagnostic trouble code No.	Detected items	Malfunction is detected when ...	Check item (remedy)
11*	Camshaft position sensor circuit	<ul style="list-style-type: none"> <li>● Either 1° or 180° signal is not entered for the first few seconds during engine cranking.</li> <li>● Either 1° or 180° signal is not input often enough while the engine speed is higher than the specified rpm.</li> </ul>	<ul style="list-style-type: none"> <li>● Harness and connector (If harness and connector are normal, replace camshaft position sensor.)</li> </ul>

GI

MA

EM

LC

EC

FE

CL

MT

AT

## TROUBLE DIAGNOSES

---

### On-board Diagnostic System — Diagnostic Test Mode II (Self-diagnostic results) (Cont'd)

#### HOW TO ERASE DIAGNOSTIC TEST MODE II (SELF-DIAGNOSTIC RESULTS)

The diagnostic trouble code is erased from the backup memory on the ECM when the diagnostic test mode is changed from Diagnostic Test Mode II to Diagnostic Test Mode I. (Refer to "HOW TO SWITCH DIAGNOSTIC TEST MODES".)

- When the battery terminal is disconnected, the diagnostic trouble code will be lost from the backup memory within 24 hours.
- Do not erase the stored memory before beginning diagnostic test mode II (Self-diagnostic results).

### On-board Diagnostic System — Diagnostic Test Mode II (Heated oxygen sensor monitor)

#### DESCRIPTION

In this mode, the MALFUNCTION INDICATOR LAMP displays the condition of the fuel mixture (lean or rich) which is monitored by the heated oxygen sensor.

## TROUBLE DIAGNOSES

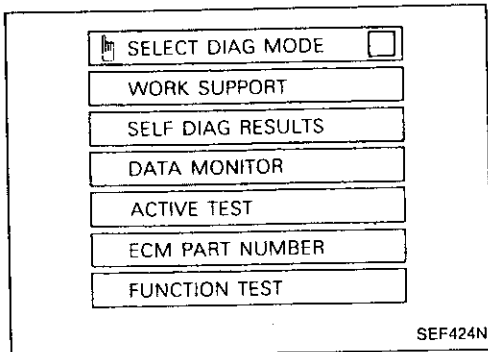
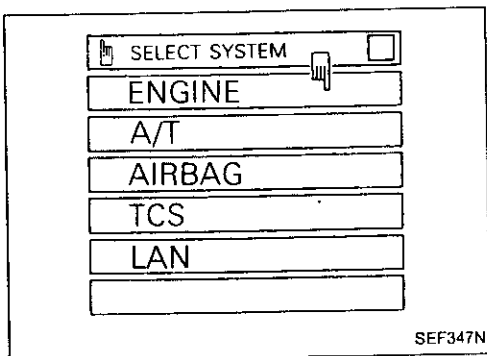
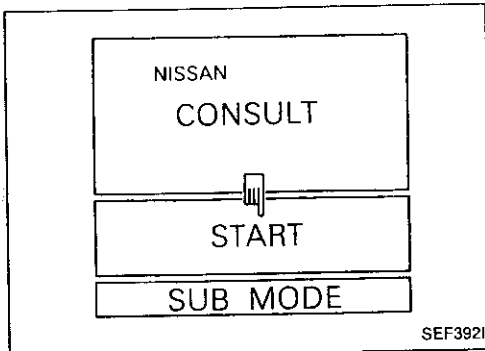
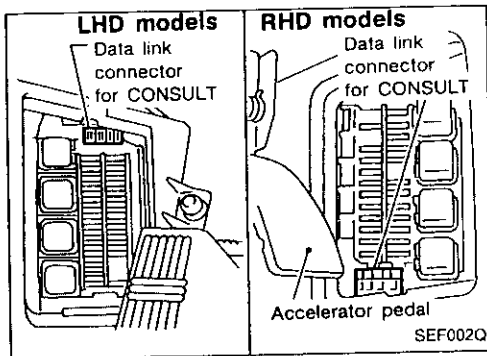

### Consult

#### CONSULT INSPECTION PROCEDURE

1. Turn off ignition switch.
2. Connect "CONSULT" to data link connector for CONSULT. (Data link connector for CONSULT is located behind the fuse box cover.)

3. Turn on ignition switch.
4. Touch "START".

5. Touch "ENGINE".

6. Perform each diagnostic test mode according to the inspection sheet as follows:  
**For further information, read the CONSULT Operation Manual.**

GI

MA

EM

LC

EC

FE

CL

MT

AT

PD

FA

RA

BR

ST

RS

BT

HA

EL

IDX

# TROUBLE DIAGNOSES

Consult (Cont'd)

## ECCS COMPONENT PARTS APPLICATION

ECCS COMPONENT PARTS	DIAGNOSTIC TEST MODE				
	WORK SUP- PORT	SELF- DIAGNOSTIC RESULTS	DATA MONI- TOR	ACTIVE TEST	FUNCTION TEST
Camshaft position sensor		X	X		
Mass air flow sensor		X	X		



## TROUBLE DIAGNOSES

### Consult (Cont'd)

#### WORK SUPPORT MODE

WORK ITEM	CONDITION	USAGE
THRTL POS SEN ADJ (THROTTLE SENSOR ADJUSTMENT)	CHECK THE THROTTLE POSITION SENSOR SIGNAL. ADJUST IT TO THE SPECIFIED VALUE BY ROTATING THE SENSOR BODY UNDER THE FOLLOWING CONDITIONS. <ul style="list-style-type: none"> <li>● IGN SW "ON"</li> <li>● ENG NOT RUNNING</li> <li>● ACC PEDAL NOT PRESSED</li> </ul>	When adjusting throttle position sensor initial position
IGNITION TIMING ADJUSTMENT	<ul style="list-style-type: none"> <li>● IGNITION TIMING FEEDBACK CONTROL WILL BE HELD BY TOUCHING "START". AFTER DOING SO, ADJUST IGNITION TIMING WITH A TIMING LIGHT BY TURNING THE CAMSHAFT POSITION SENSOR.</li> </ul>	When adjusting initial ignition timing
IACV-AAC VALVE ADJ (AAC VALVE ADJUSTMENT)	SET ENGINE RPM AT THE SPECIFIED VALUE UNDER THE FOLLOWING CONDITIONS. <ul style="list-style-type: none"> <li>● ENGINE WARMED UP</li> <li>● NO-LOAD</li> </ul>	When adjusting idle speed
FUEL PRESSURE RELEASE	<ul style="list-style-type: none"> <li>● FUEL PUMP WILL STOP BY TOUCHING "START" DURING IDLE. CRANK A FEW TIMES AFTER ENGINE STALLS.</li> </ul>	When releasing fuel pressure from fuel line

#### SELF-DIAGNOSTIC RESULTS MODE

DIAGNOSTIC ITEM	DIAGNOSTIC ITEM IS DETECTED WHEN ....	CHECK ITEM (REMEDY)
CAMSHAFT POSI SEN* (CRANK ANGLE SENSOR*)	<ul style="list-style-type: none"> <li>● Either 1° or 180° signal is not entered for the first few seconds during engine cranking.</li> <li>● Either 1° or 180° signal is not input often enough while the engine speed is higher than the specified rpm.</li> </ul>	<ul style="list-style-type: none"> <li>● Harness and connector (If harness and connector are normal, replace camshaft position sensor.)</li> </ul>
MASS AIR FLOW SEN (AIR FLOW METER)	<ul style="list-style-type: none"> <li>● The mass air flow sensor circuit is open or shorted. (An abnormally high or low voltage is entered.)</li> </ul>	<ul style="list-style-type: none"> <li>● Harness and connector (If harness and connector are normal, replace mass air flow sensor.)</li> </ul>
COOLANT TEMP SEN (ENGINE TEMP SENSOR)	<ul style="list-style-type: none"> <li>● The engine coolant temperature sensor circuit is open or shorted. (An abnormally high or low output voltage is entered.)</li> </ul>	<ul style="list-style-type: none"> <li>● Harness and connector</li> <li>● Engine coolant temperature sensor</li> </ul>
IGN SIGNAL — PRIMARY*	<ul style="list-style-type: none"> <li>● The ignition signal in primary circuit is not entered during engine cranking or running.</li> </ul>	<ul style="list-style-type: none"> <li>● Harness and connector</li> <li>● Power transistor unit</li> </ul>
KNOCK SENSOR (DETONATION SENSOR)	<ul style="list-style-type: none"> <li>● The knock sensor circuit is open or shorted. (An abnormally high or low voltage is entered.)</li> </ul>	<ul style="list-style-type: none"> <li>● Harness and connector</li> <li>● Knock sensor</li> </ul>
THROTTLE POSI SEN (THROTTLE SENSOR)	<ul style="list-style-type: none"> <li>● The throttle position sensor circuit is open or shorted. (An abnormally high or low voltage is entered.)</li> </ul>	<ul style="list-style-type: none"> <li>● Harness and connector</li> <li>● Throttle position sensor</li> </ul>
A/T COMM LINE	<ul style="list-style-type: none"> <li>● The A/T communication line is open or shorted.</li> </ul>	<ul style="list-style-type: none"> <li>● Harness and connector</li> </ul>

\*: Check items causing a malfunction of camshaft position sensor circuit first, if both "CAMSHAFT POSI SEN (No. 11)" and "IGN SIGNAL-PRIMARY (No. 21)" are displayed one after the other.

- Sensor failures which set a self-diagnosis code are listed as due to an open or short circuit.
- A sensor sending a signal which is inaccurate but not open or short will NOT set a self-diagnosis code.
- If a driveability symptom is present but no self-diagnosis code is set, perform further inspections using DATA MONITOR.

## TROUBLE DIAGNOSES

### Consult (Cont'd)

#### DATA MONITOR MODE

Remarks : ● Specification data are reference values.

- Specification data are output/input values which are detected or supplied by ECM at the connector.

\*Specification data may not be directly related to their components signals/values/operations.

ie. Adjust ignition timing with a timing light before monitoring IGN TIMING, because the monitor may show the specification data in spite of the ignition timing being not adjusted to the specification data. This IGN TIMING monitors the calculated data by ECM according to the input signals from camshaft position sensor and other ignition timing related sensors.

- If the real-time diagnosis results are NG and the self-diagnostic results are OK when diagnosing the mass air flow sensor, first check to see if the fuel pump control circuit is normal.

MONITOR ITEM	CONDITION		SPECIFICATION	CHECK ITEM WHEN OUTSIDE SPEC.
CMPS-RPM (REF) (CAS-RPM (REF))	<ul style="list-style-type: none"> <li>● Tachometer: Connect</li> <li>● Run engine and compare tachometer indication with the CONSULT value.</li> </ul>		Almost the same speed as the CONSULT value.	<ul style="list-style-type: none"> <li>● Harness and connector</li> <li>● Camshaft position sensor</li> </ul>
MAS AIR/ FL SE (AIR FLOW MTR)	<ul style="list-style-type: none"> <li>● Engine: After warming up, idle the engine</li> <li>● A/C switch "OFF"</li> <li>● Selector lever "N" position</li> <li>● No-load</li> </ul>	Idle	0.8 - 1.5V	<ul style="list-style-type: none"> <li>● Harness and connector</li> <li>● Mass air flow sensor</li> </ul>
		3,000 rpm	1.4 - 2.0V	
COOLANT TEMP/S (ENG TEMP SEN)	<ul style="list-style-type: none"> <li>● Engine: After warming up</li> </ul>		More than 70°C (158°F)	<ul style="list-style-type: none"> <li>● Harness and connector</li> <li>● Engine coolant temperature sensor</li> </ul>
O2 SEN (EXH GAS SEN)	<ul style="list-style-type: none"> <li>● Engine: After warming up</li> </ul>	Maintaining engine speed at 2,000 rpm	0 - 0.3V → 0.6 - 0.9V	<ul style="list-style-type: none"> <li>● Harness and connector</li> <li>● Heated oxygen sensor</li> <li>● Intake air leaks</li> <li>● Injectors</li> </ul>
M/R F/C MNT			LEAN → RICH Changes more than 5 times during 10 seconds.	
VHCL SPEED SE (CAR SPEED SEN)	<ul style="list-style-type: none"> <li>● Turn drive wheels and compare speedometer indication with the CONSULT value</li> </ul>		Almost the same speed as the CONSULT value	<ul style="list-style-type: none"> <li>● Harness and connector</li> <li>● Vehicle speed sensor</li> </ul>
BATTERY VOLT	<ul style="list-style-type: none"> <li>● Ignition switch: ON (Engine stopped)</li> </ul>		11 - 14V	<ul style="list-style-type: none"> <li>● Battery</li> <li>● ECM power supply circuit</li> </ul>
THRTL POS SEN (THROTTLE SEN)	<ul style="list-style-type: none"> <li>● Ignition switch: ON (Engine stopped)</li> </ul>	Throttle valve fully closed (Engine: After warming up)	0.35 - 0.65V	<ul style="list-style-type: none"> <li>● Harness and connector</li> <li>● Throttle position sensor</li> <li>● Throttle position sensor adjustment</li> </ul>
		Throttle valve fully open	Approx. 4.0V	
START SIGNAL	<ul style="list-style-type: none"> <li>● Ignition switch: ON → START</li> </ul>		OFF → ON	<ul style="list-style-type: none"> <li>● Harness and connector</li> <li>● Starter switch</li> </ul>
CLOSED TH/POS (IDLE POSITION)	<ul style="list-style-type: none"> <li>● Ignition switch: ON (Engine stopped)</li> </ul>	Throttle valve: Closed throttle position (Engine: After warming up)	ON	<ul style="list-style-type: none"> <li>● Harness and connector</li> <li>● Throttle position sensor</li> <li>● Throttle position sensor adjustment</li> <li>● Throttle position switch</li> </ul>
		Throttle valve: Slightly open	OFF	
AIR COND SIG	<ul style="list-style-type: none"> <li>● Engine: After warming up, idle the engine</li> </ul>	A/C switch "OFF"	OFF	<ul style="list-style-type: none"> <li>● Harness and connector</li> <li>● Air conditioner switch</li> </ul>
		A/C switch "ON"	ON	
NEUT POSI SW (NEUTRAL SW)	<ul style="list-style-type: none"> <li>● Ignition switch: ON</li> </ul>	Shift lever "P" or "N"	ON	<ul style="list-style-type: none"> <li>● Harness and connector</li> <li>● Neutral position switch</li> </ul>
		Except above	OFF	
PW/ST SIGNAL	<ul style="list-style-type: none"> <li>● Engine: After warming up, idle the engine</li> </ul>	Steering wheel in neutral position (forward direction)	OFF	<ul style="list-style-type: none"> <li>● Harness and connector</li> <li>● Power steering oil pressure switch</li> </ul>
		The steering wheel is turned	ON	

## TROUBLE DIAGNOSES

### Consult (Cont'd)

MONITOR ITEM	CONDITION		SPECIFICATION	CHECK ITEM WHEN OUTSIDE SPEC.	
INJ PULSE	<ul style="list-style-type: none"> <li>● Engine: After warming up</li> <li>● A/C switch "OFF"</li> <li>● Selector lever "N" position</li> <li>● No-load</li> </ul>	Idle	1.7 - 2.5 msec.	<ul style="list-style-type: none"> <li>● Harness and connector</li> <li>● Injector</li> <li>● Mass air flow sensor</li> <li>● Intake air system</li> </ul>	GI
		2,000 rpm	1.5 - 2.3 msec.		MA
IGN TIMING	ditto	Idle	15° BTDC	<ul style="list-style-type: none"> <li>● Harness and connector</li> <li>● Camshaft position sensor</li> </ul>	EM
		2,000 rpm	More than 25° BTDC		
IACV-AAC/V (AAC VALVE)	ditto	Idle	20 - 40%	<ul style="list-style-type: none"> <li>● Harness and connector</li> <li>● IACV-AAC valve</li> </ul>	LC
		2,000 rpm	—		
A/F ALPHA	<ul style="list-style-type: none"> <li>● Engine: After warming up</li> </ul>	Maintaining engine speed at 2,000 rpm	75 - 125%	<ul style="list-style-type: none"> <li>● Harness and connector</li> <li>● Injector</li> <li>● Mass air flow sensor</li> <li>● Heated oxygen sensor</li> <li>● Carbon canister purge line</li> <li>● Intake air system</li> </ul>	EC
AIR COND RLY	Engine: After warming up, idle the engine Air conditioner switch OFF → ON		OFF → ON	<ul style="list-style-type: none"> <li>● Harness and connector</li> <li>● Air conditioner switch</li> <li>● Air conditioner relay</li> </ul>	CL
FUEL PUMP RLY	<ul style="list-style-type: none"> <li>● Ignition switch is turned to ON (Operates for 1 second)</li> <li>● Engine running and cranking</li> <li>● When engine is stopped (stops in 1 second)</li> </ul>		ON	<ul style="list-style-type: none"> <li>● Harness and connector</li> <li>● Fuel pump relay</li> </ul>	MT
	Except as shown above		OFF		AT
VALVE TIM SOL	<ul style="list-style-type: none"> <li>● Jack up rear wheel</li> <li>● Engine: After warming up</li> </ul>	<ul style="list-style-type: none"> <li>● Idle</li> <li>● Shift selector lever to any position except "N" or "P" position</li> <li>● Quickly depress accelerator pedal, then quickly release it</li> </ul>	OFF → ON → OFF	<ul style="list-style-type: none"> <li>● Harness and connector</li> <li>● Valve timing solenoid valve</li> </ul>	PD
			OFF		EA
COOLING FAN (RADIATOR FAN)	<ul style="list-style-type: none"> <li>● When cooling fan is stopped.</li> </ul>		OFF	<ul style="list-style-type: none"> <li>● Harness and connector</li> <li>● Cooling fan relay</li> <li>● Cooling fan motor</li> </ul>	RA
	<ul style="list-style-type: none"> <li>● When cooling fan operates at low speed</li> </ul>		LOW		
	<ul style="list-style-type: none"> <li>● When cooling fan operates at high speed</li> </ul>		HI		
EGRC SOL/V (EGR CQNT S/V)	<ul style="list-style-type: none"> <li>● Engine: After warming up</li> <li>● A/C switch "OFF"</li> <li>● Shift lever "N"</li> <li>● No-load</li> </ul>	Idle	ON	<ul style="list-style-type: none"> <li>● Harness and connector</li> <li>● EGRC-solenoid valve</li> </ul>	BR
		2,000 rpm	OFF		ST
W/G CONT S/V	ditto	Idle	0%	<ul style="list-style-type: none"> <li>● Harness and connector</li> <li>● Wastegate valve control solenoid valve</li> </ul>	RS
		Racing up to 4,000 rpm	20%		

## TROUBLE DIAGNOSES

### Consult (Cont'd)

#### ACTIVE TEST MODE

TEST ITEM	CONDITION	JUDGEMENT	CHECK ITEM (REMEDY)
FUEL INJECTION	<ul style="list-style-type: none"> <li>● Engine: Return to the original trouble condition</li> <li>● Change the amount of fuel injection with the CONSULT.</li> </ul>	If trouble symptom disappears, see CHECK ITEM.	<ul style="list-style-type: none"> <li>● Harness and connector</li> <li>● Fuel injectors</li> <li>● Heated oxygen sensors</li> </ul>
IACV-AAC/V OPENING (AAC/V OPENING)	<ul style="list-style-type: none"> <li>● Engine: After warming up, idle the engine.</li> <li>● Change the IACV-AAC valve opening percent with the CONSULT.</li> </ul>	Engine speed changes according to the opening percent.	<ul style="list-style-type: none"> <li>● Harness and connector</li> <li>● IACV-AAC valve</li> </ul>
ENG COOLANT TEMP (ENGINE TEMPERATURE)	<ul style="list-style-type: none"> <li>● Engine: Return to the original trouble condition</li> <li>● Change the engine coolant temperature with the CONSULT.</li> </ul>	If trouble symptom disappears, see CHECK ITEM.	<ul style="list-style-type: none"> <li>● Harness and connector</li> <li>● Engine coolant temperature sensor</li> <li>● Fuel injectors</li> </ul>
IGNITION TIMING	<ul style="list-style-type: none"> <li>● Engine: Return to the original trouble condition</li> <li>● Timing light: Set</li> <li>● Retard the ignition timing with the CONSULT.</li> </ul>	If trouble symptom disappears, see CHECK ITEM.	<ul style="list-style-type: none"> <li>● Adjust initial ignition timing</li> </ul>
POWER BALANCE	<ul style="list-style-type: none"> <li>● Engine: After warming up, idle the engine.</li> <li>● A/C switch "OFF"</li> <li>● Selector lever "N" position</li> <li>● Cut off each injector signal one at a time with the CONSULT.</li> </ul>	Engine runs rough or dies.	<ul style="list-style-type: none"> <li>● Harness and connector</li> <li>● Compression</li> <li>● Injectors</li> <li>● Power transistor</li> <li>● Spark plugs</li> <li>● Ignition coils</li> </ul>
COOLING FAN (RADIATOR FAN)	<ul style="list-style-type: none"> <li>● Ignition switch: ON</li> <li>● Turn cooling fan "LOW", "HI" and "OFF" with CONSULT</li> </ul>	Cooling fan moves at low and high speed, and stops.	<ul style="list-style-type: none"> <li>● Harness and connector</li> <li>● Cooling fan relay</li> <li>● Cooling fan motor</li> </ul>
FUEL PUMP RELAY	<ul style="list-style-type: none"> <li>● Ignition switch: ON (Engine stopped)</li> <li>● Turn the fuel pump relay "ON" and "OFF" with the CONSULT and listen to operating sound.</li> </ul>	Fuel pump relay makes the operating sound.	<ul style="list-style-type: none"> <li>● Harness and connector</li> <li>● Fuel pump relay</li> </ul>
EGRC SOLENOID VALVE (EGR CONT SOL VALVE)	<ul style="list-style-type: none"> <li>● Ignition switch: ON</li> <li>● Turn solenoid valve "ON" and "OFF" with the CONSULT and listen to operating sound.</li> </ul>	Each solenoid valve makes an operating sound.	<ul style="list-style-type: none"> <li>● Harness and connector</li> <li>● Solenoid valve</li> </ul>
VALVE TIM SOL			
SELF-LEARNING CONT	<ul style="list-style-type: none"> <li>● In this test, the coefficient of self-learning control mixture ratio returns to the original coefficient by touching "CLEAR" on the screen.</li> </ul>		

## TROUBLE DIAGNOSES

### Consult (Cont'd)

#### FUNCTION TEST MODE

FUNCTION TEST ITEM	CONDITION	JUDGEMENT		CHECK ITEM (REMEDY)	
SELF-DIAG RESULTS	<ul style="list-style-type: none"> <li>Ignition switch: ON (Engine stopped)</li> <li>Displays the self-diagnostic results.</li> </ul>	—		Objective system	GI MA EM LC EC FE
CLOSED THROTTLE POSI (CLOSED THROTTLE POSITION SWITCH CIRCUIT) (IDLE POSITION (IDLE SWITCH CIRCUIT))	<ul style="list-style-type: none"> <li>Ignition switch: ON (Engine stopped)</li> <li>Closed throttle position switch circuit is tested when throttle is opened and closed fully. ("CLOSED THROTTLE POSI" is the test item name for the vehicles in which idle is selected by throttle position sensor.)</li> </ul>	Throttle valve: opened	OFF	<ul style="list-style-type: none"> <li>Harness and connector</li> <li>Throttle position sensor (Closed throttle position switch)</li> <li>Throttle position sensor (Closed throttle position switch) adjustment</li> <li>Throttle linkage</li> <li>Verify operation in DATA MONITOR mode.</li> </ul>	CL MT AT PD
		Throttle valve: closed	ON		
THROTTLE POSI SEN CKT (THROTTLE SENSOR CKT)	<ul style="list-style-type: none"> <li>Ignition switch: ON (Engine stopped)</li> <li>Throttle position sensor circuit is tested when throttle is opened and closed fully.</li> </ul>	Range (Throttle valve fully opened — Throttle valve fully closed)	More than 3.0V	<ul style="list-style-type: none"> <li>Harness and connector</li> <li>Throttle position sensor</li> <li>Throttle position sensor adjustment</li> <li>Throttle linkage</li> <li>Verify operation in DATA MONITOR mode.</li> </ul>	CL MT AT
NEUTRAL POSI SW CKT (NEUTRAL SW CIRCUIT)	<ul style="list-style-type: none"> <li>Ignition switch: ON (Engine stopped)</li> <li>Neutral position switch circuit is tested when shift lever is manipulated.</li> </ul>	OUT OF N/P-POSITION	OFF	<ul style="list-style-type: none"> <li>Harness and connector</li> <li>Neutral position switch/ Inhibitor switch</li> <li>Linkage + Inhibitor switch adjustment</li> </ul>	AT PD
		IN N-POSITION	ON		
FUEL PUMP CIRCUIT	<ul style="list-style-type: none"> <li>Ignition switch: ON (Engine stopped)</li> <li>Fuel pump circuit is tested by checking the pulsation in fuel pressure when fuel tube is pinched.</li> </ul>	There is pressure pulsation on the fuel feed hose.		<ul style="list-style-type: none"> <li>Harness and connector</li> <li>Fuel pump</li> <li>Fuel pump relay</li> <li>Fuel filter clogging</li> <li>Fuel level</li> </ul>	FA RA
EGRC SOL/V CIRCUIT (EGR CONT S/V CIRCUIT)	<ul style="list-style-type: none"> <li>Ignition switch: ON (Engine stopped)</li> <li>EGR control S/V circuit is tested by checking solenoid valve operating noise.</li> </ul>	The solenoid valve makes an operating sound every 3 seconds.		<ul style="list-style-type: none"> <li>Harness and connector</li> <li>EGRC-solenoid valve</li> </ul>	BR ST
VALVE TIMING S/V CKT	<ul style="list-style-type: none"> <li>Ignition switch: ON (Engine stopped)</li> <li>Valve timing S/V circuit is tested by checking solenoid valve operating noise.</li> </ul>	The solenoid valve makes an operating sound every 3 seconds.		<ul style="list-style-type: none"> <li>Harness and connector</li> <li>Valve timing solenoid valve</li> </ul>	RS BT
COOLING FAN CIRCUIT (RADIATOR FAN CIRCUIT)	<ul style="list-style-type: none"> <li>Ignition switch: ON (Engine stopped)</li> <li>Cooling fan circuit is tested by checking cooling fan operation.</li> </ul>	<ul style="list-style-type: none"> <li>The cooling fan rotates and stops every 3 seconds.</li> </ul>		<ul style="list-style-type: none"> <li>Harness and connector</li> <li>Cooling fan relay</li> <li>Cooling fan motor</li> </ul>	HA EL IDX

## TROUBLE DIAGNOSES

### Consult (Cont'd)

FUNCTION TEST ITEM	CONDITION	JUDGEMENT		CHECK ITEM (REMEDY)
START SIGNAL CIRCUIT	<ul style="list-style-type: none"> <li>● Ignition switch: ON → START</li> <li>● Start signal circuit is tested when engine is started by operating the starter. Battery voltage and water temperature before cranking, and average battery voltage, mass air flow sensor output voltage and cranking speed during cranking are displayed.</li> </ul>	Start signal: OFF → ON		<ul style="list-style-type: none"> <li>● Harness and connector</li> <li>● Ignition switch</li> </ul>
PW/ST SIGNAL CIRCUIT	<ul style="list-style-type: none"> <li>● Ignition switch: ON (Engine running)</li> <li>● Power steering circuit is tested when steering wheel is rotated fully and then set to a straight line running position.</li> </ul>	Locked position	ON	<ul style="list-style-type: none"> <li>● Harness and connector</li> <li>● Power steering oil pressure switch</li> <li>● Power steering oil pump</li> </ul>
		Neutral position	OFF	
VEHICLE SPEED SEN CKT (CAR SPEED SEN CIRCUIT)	<ul style="list-style-type: none"> <li>● Vehicle speed sensor circuit is tested when vehicle is running at a speed of 10 km/h (6 mph) or higher.</li> </ul>	Vehicle speed sensor input signal is greater than 4 km/h (2 MPH)		<ul style="list-style-type: none"> <li>● Harness and connector</li> <li>● Vehicle speed sensor</li> <li>● Electric speedometer</li> </ul>
IGN TIMING ADJ	<ul style="list-style-type: none"> <li>● After warming up, idle the engine.</li> <li>● Ignition timing adjustment is checked by reading ignition timing with a timing light and checking whether it agrees with specifications.</li> </ul>	The timing light indicates the same value on the screen.		<ul style="list-style-type: none"> <li>● Adjust ignition timing (by moving camshaft position sensor or distributor)</li> <li>● Camshaft position sensor drive mechanism</li> </ul>
MIXTURE RATIO TEST	<ul style="list-style-type: none"> <li>● Air-fuel ratio feedback circuit (injection system, ignition system, vacuum system, etc.) is tested by examining the heated oxygen sensor output at 2,000 rpm under non-loaded state.</li> </ul>	<ul style="list-style-type: none"> <li>● O2 SEN COUNT: More than 5 times during 10 seconds</li> </ul>		<ul style="list-style-type: none"> <li>● INJECTION SYS (Injector, fuel pressure regulator, harness or connector)</li> <li>● IGNITION SYS (Spark plug, power transistor, ignition coil, harness or connector)</li> <li>● VACUUM SYS (Intake air leaks)</li> <li>● Heated oxygen sensor circuit</li> <li>● Heated oxygen sensor operation</li> <li>● Fuel pressure high or low</li> <li>● Mass air flow sensor</li> </ul>

## TROUBLE DIAGNOSES

### Consult (Cont'd)

FUNCTION TEST ITEM	CONDITION	JUDGEMENT	CHECK ITEM (REMEDY)
POWER BALANCE	<ul style="list-style-type: none"> <li>● After warming up, idle the engine.</li> <li>● Injector operation of each cylinder is stopped one after another, and resultant change in engine rotation is examined to evalu-</li> </ul>	Difference in engine speed is greater than 25 rpm before and after cutting off the injector of each cylinder.	<ul style="list-style-type: none"> <li>● Injector circuit (Injector, harness or connector)</li> <li>● Ignition circuit (Spark plug, power transistor, ignition coil, harness or</li> </ul>

GI

MA

EM

## TROUBLE DIAGNOSES

### Diagnostic Procedure (Cont'd)

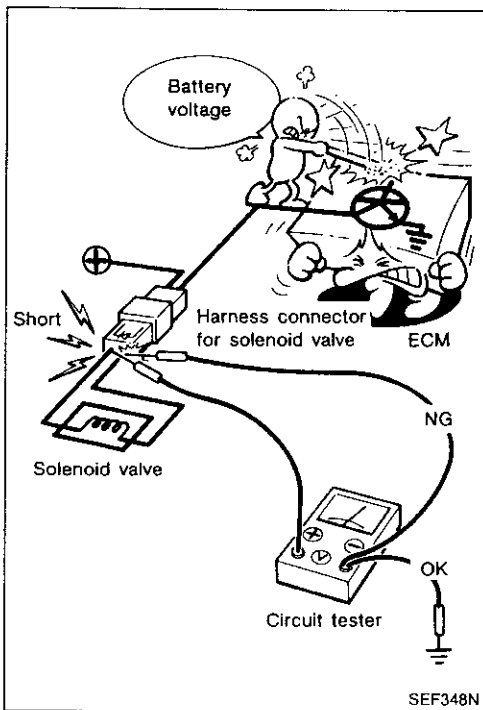
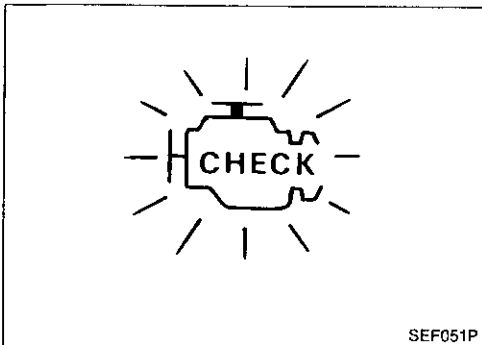
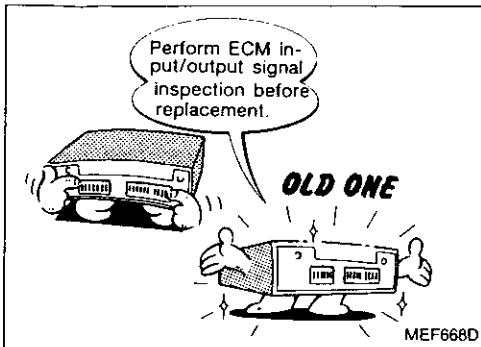

5. Before replacing ECM, perform ECM input/output signal inspection and make sure whether ECM functions properly or not. (See page EC-196.)

6. After performing this "Diagnostic Procedure", perform diagnostic test mode II (Self-diagnostic results) and driving test.

7. When measuring ECM signals with a circuit tester, never bring the two tester probes into contact. Accidental contact of probes will cause a short circuit and damage the ECM power transistor.



# TROUBLE DIAGNOSES

## Basic Inspection

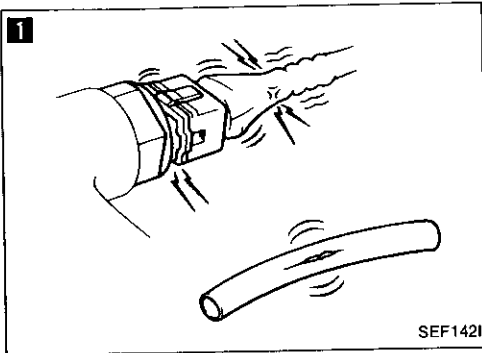

**1**

### BEFORE STARTING

1. Check service records for any recent repairs that may indicate a related problem, or the current need for scheduled maintenance.
2. Open engine hood and check the following:
  - Harness connectors for proper connections
  - Vacuum hoses for splits, kinks, and proper connections
  - Wiring for proper connections, pinches, and cuts

**2**

### CONNECT CONSULT TO THE VEHICLE.

Connect "CONSULT" to the data link connector for CONSULT and select "ENGINE" from the menu. (Refer to page EC-53.)

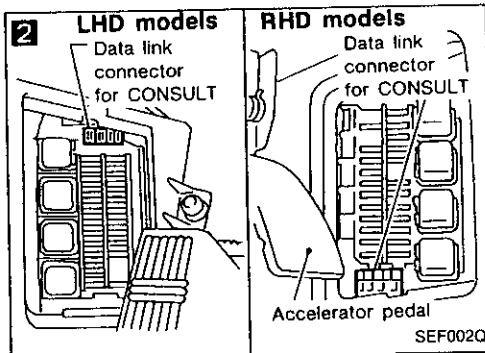

**3**

**DOES ENGINE START?**

No → Go to **6**

Yes

**4**

### CHECK IGNITION TIMING.

Warm up engine sufficiently and check ignition timing at idle using timing light. (Refer to page EC-33.)

**Ignition timing:  $15^\circ \pm 2^\circ$  BTDC**

NG → Adjust ignition timing by turning camshaft position sensor.

OK

(Go to **A** on next page.)

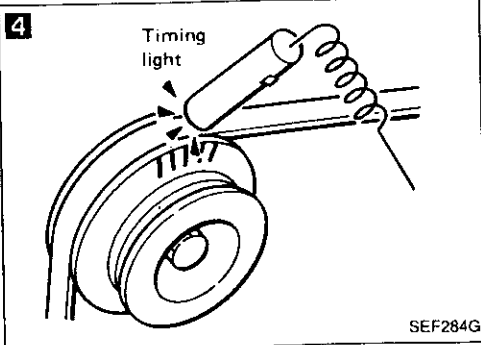
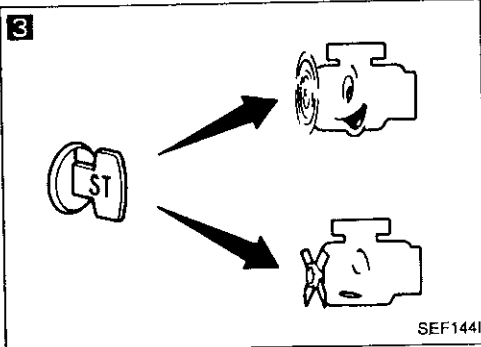

GI

MA

EM

LC

**EC**

FE

CL

MT

AT

PD

FA

RA

BR

ST

RS

BT

HA

EL

IDX

# TROUBLE DIAGNOSES

## Basic Inspection (Cont'd)

**5**

■ IGN TIMING ADJ ■ □

IGNITION TIMING FEEDBACK CONTROL WILL BE HELD BY TOUCHING START. AFTER DOING SO, ADJUST IGNITION TIMING WITH A TIMING LIGHT BY TURNING THE CRANK ANGLE SENSOR.

START

SEF816K

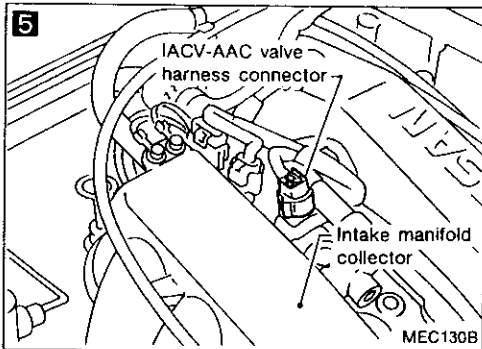

**6**

■ THROTTLE SEN ADJ ■

\*\*\* ADJ MONITOR \*\*\*

THROTTLE SEN 0.45V

===== MONITOR =====

CAS-RPM (REF) 0rpm

IDLE POSITION ON

MEC157B

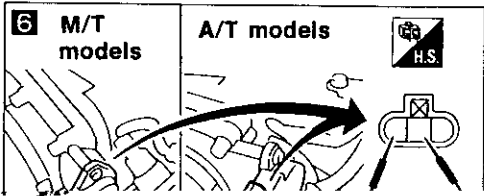

A

**5**

**CHECK IDLE ADJ. SCREW INITIAL SET RPM.**

1. Select "IGN TIMING ADJ" in "WORK SUPPORT" mode.

2. When touching "START", does engine speed fall to  $750 \pm 50$  rpm (A/T in "N" position)?

OR

3. When disconnecting throttle position sensor harness connector, does engine speed fall to  $750 \pm 50$  rpm (A/T in "N" position)?

NG → Adjust engine speed by turning idle adjusting screw.

OK

**6**

**CHECK THROTTLE POSITION SENSOR IDLE POSITION.**

1. Perform "THROTTLE SEN ADJ" or "THRTL POS SEN ADJ" in "WORK SUPPORT" mode.

2. Check that output voltage of throttle position sensor is 0.35 to 0.65V. (Throttle valve fully closes.) and "IDLE POSITION" or "CLOSED TH/POS" stays "ON".

OR

3. Measure output voltage of throttle position sensor using voltmeter, and check that it is 0.35 to 0.65V. (Throttle valve fully closed.)

NG →

1. Adjust output voltage by rotating throttle position sensor body.
2. Disconnect throttle position sensor harness connector for a few seconds and then reconnect it.
3. Confirm that "IDLE POSITION" or "CLOSED TH/POS" stays "ON".

OK

# TROUBLE DIAGNOSES

## Basic Inspection (Cont'd)

**7**

☆ MONITOR	☆ NO FAIL	<input type="checkbox"/>
START SIGNAL	OFF	
IDLE POSITION	ON	
AIR COND SIG	OFF	
NEUTRAL SW	ON	

RECORD

SEF384J

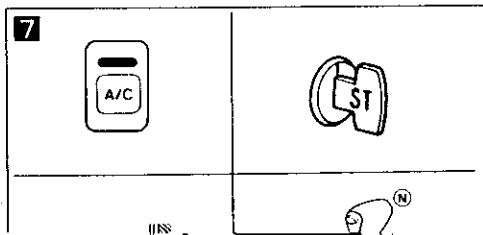

8

**7**

**CHECK SWITCH INPUT SIGNAL.**

Select the following switches in "DATA MONITOR" mode,

- a) Start signal,
- b) Idle position or closed throttle position,
- c) Air conditioner signal,
- d) Neutral (Parking) position switch, and check the switches' ON-OFF operation.

OR

Remove ECM from front dash side and check the above switches' ON-OFF operation using voltmeter at each ECM terminal.

NG

Repair or replace the malfunctioning switch or its circuit.

GI

MA

EM







LC

EC

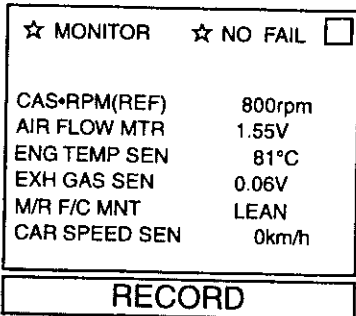
FE

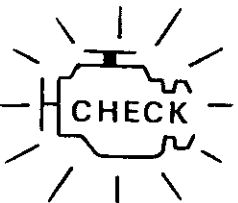

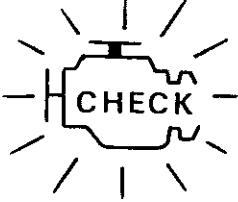

## TROUBLE DIAGNOSES

### How to Execute On-board Diagnostic System in Diagnostic Test Mode II

Detected items	Display Diagnostic trouble code No.	How to perform diagnostic test mode II (Self-diagnostic results) judgement	
		Illustration	Method
Camshaft position sensor circuit	11	 <p style="text-align: right;">SEF004Q</p>	<p><b>PERFORM DIAGNOSTIC TEST MODE II (SELF-DIAGNOSTIC RESULTS).</b></p> <p>1) Start engine.</p> <p> 2) Select "DATA MONITOR" mode with CONSULT. ☆ <b>NO FAIL</b></p> <p style="text-align: center;">OR</p> <p> 2) Turn ignition switch "OFF" and then "ON".</p> <p>3) Perform diagnostic test mode II (Self-diagnostic results) with ECM. <b>Malfunction indicator lamp displays diagnostic trouble code No. 55.</b></p>
		 <p style="text-align: right;">SEF051P</p>	
Mass air flow sensor circuit	12	 <p style="text-align: right;">SEF004Q</p>	<p><b>PERFORM DIAGNOSTIC TEST MODE II (SELF-DIAGNOSTIC RESULTS).</b></p> <p>1) Turn ignition switch "ON" wait for at least 5 seconds and then start engine.</p> <p> 2) Select "DATA MONITOR" mode with CONSULT. ☆ <b>NO FAIL</b></p> <p style="text-align: center;">OR</p> <p> 2) Perform diagnostic test mode II (Self-diagnostic results) with ECM. <b>Malfunction indicator lamp displays diagnostic trouble code No. 55.</b></p>
		 <p style="text-align: right;">SEF051P</p>	

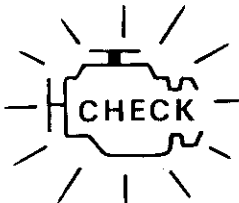
# TROUBLE DIAGNOSES

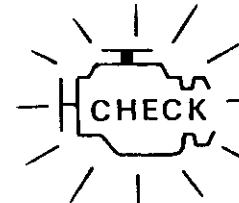
## How to Execute On-board Diagnostic System in Diagnostic Test Mode II (Cont'd)

Detected items	Display Diagnostic trouble code No.	How to perform diagnostic test mode II (Self-diagnostic results) judgement														
		Illustration	Method													
Engine coolant temperature sensor circuit	13	<div style="border: 1px solid black; padding: 5px; margin-bottom: 10px;"> <div style="display: flex; justify-content: space-between;"> <span>☆ MONITOR</span> <span>☆ NO FAIL <input type="checkbox"/></span> </div> <table style="width: 100%; border-collapse: collapse;"> <tr><td>CAS•RPM(REF)</td><td style="text-align: right;">800rpm</td></tr> <tr><td>AIR FLOW MTR</td><td style="text-align: right;">1.55V</td></tr> <tr><td>ENG TEMP SEN</td><td style="text-align: right;">81°C</td></tr> <tr><td>EXH GAS SEN</td><td style="text-align: right;">0.06V</td></tr> <tr><td>M/R F/C MNT</td><td style="text-align: right;">LEAN</td></tr> <tr><td>CAR SPEED SEN</td><td style="text-align: right;">0km/h</td></tr> </table> <div style="border: 1px solid black; text-align: center; padding: 2px; margin-top: 5px;"><b>RECORD</b></div> </div> <p style="text-align: right; font-size: small;">SEF004Q</p> <div style="text-align: center; margin-top: 20px;">  </div> <p style="text-align: right; font-size: small;">SEF051P</p>	CAS•RPM(REF)	800rpm	AIR FLOW MTR	1.55V	ENG TEMP SEN	81°C	EXH GAS SEN	0.06V	M/R F/C MNT	LEAN	CAR SPEED SEN	0km/h	<p><b>PERFORM DIAGNOSTIC TEST MODE II (SELF-DIAGNOSTIC RESULTS).</b></p> <p>1) Turn ignition switch "ON" or start engine.</p> <p> 2) Select "DATA MONITOR" mode with CONSULT. ☆ <b>NO FAIL</b></p> <p style="text-align: center;">OR</p> <p> 2) Perform diagnostic test mode II (Self-diagnostic results) with ECM. <b>Malfunction indicator lamp displays diagnostic trouble code No. 55.</b></p>	GI MA EM LC <b>EC</b> FE CL MT AT
CAS•RPM(REF)	800rpm															
AIR FLOW MTR	1.55V															
ENG TEMP SEN	81°C															
EXH GAS SEN	0.06V															
M/R F/C MNT	LEAN															
CAR SPEED SEN	0km/h															
Ignition signal circuit	21	<div style="border: 1px solid black; padding: 5px; margin-bottom: 10px;"> <div style="display: flex; justify-content: space-between;"> <span>☆ MONITOR</span> <span>☆ NO FAIL <input type="checkbox"/></span> </div> <table style="width: 100%; border-collapse: collapse;"> <tr><td>CAS•RPM(REF)</td><td style="text-align: right;">800rpm</td></tr> <tr><td>AIR FLOW MTR</td><td style="text-align: right;">1.55V</td></tr> <tr><td>ENG TEMP SEN</td><td style="text-align: right;">81°C</td></tr> <tr><td>EXH GAS SEN</td><td style="text-align: right;">0.06V</td></tr> <tr><td>M/R F/C MNT</td><td style="text-align: right;">LEAN</td></tr> <tr><td>CAR SPEED SEN</td><td style="text-align: right;">0km/h</td></tr> </table> <div style="border: 1px solid black; text-align: center; padding: 2px; margin-top: 5px;"><b>RECORD</b></div> </div> <p style="text-align: right; font-size: small;">SEF004Q</p> <div style="text-align: center; margin-top: 20px;">  </div> <p style="text-align: right; font-size: small;">SEF051P</p>	CAS•RPM(REF)	800rpm	AIR FLOW MTR	1.55V	ENG TEMP SEN	81°C	EXH GAS SEN	0.06V	M/R F/C MNT	LEAN	CAR SPEED SEN	0km/h	<p><b>PERFORM DIAGNOSTIC TEST MODE II (SELF-DIAGNOSTIC RESULTS).</b></p> <p>1) Start engine.</p> <p> 2) Select "DATA MONITOR" mode with CONSULT. ☆ <b>NO FAIL</b></p> <p style="text-align: center;">OR</p> <p> 2) Turn ignition switch "OFF" and then "ON".</p> <p>3) Perform diagnostic test mode II (Self-diagnostic results) with ECM. <b>Malfunction indicator lamp displays diagnostic trouble code No. 55.</b></p>	PD FA RA BR ST RS BT HA
CAS•RPM(REF)	800rpm															
AIR FLOW MTR	1.55V															
ENG TEMP SEN	81°C															
EXH GAS SEN	0.06V															
M/R F/C MNT	LEAN															
CAR SPEED SEN	0km/h															

\*: Diagnostic test mode II (Self-diagnostic results) is not performed but this method provides results which are equal to the self-diagnostic results.

IDX

## TROUBLE DIAGNOSES

### How to Execute On-board Diagnostic System in Diagnostic Test Mode II (Cont'd)

Detected items	Display Diagnostic trouble code No.	How to perform diagnostic test mode II (Self-diagnostic results) judgement	
		Illustration	Method
		<div style="border: 1px solid black; padding: 5px; width: fit-content; margin: auto;"> <p>☆ MONITOR    ☆ NO FAIL    <input type="checkbox"/></p> <p>CAS-RPM(REF)    800rpm</p> <p>AIR FLOW MTR    1.55V</p> <p>ENG TEMP SEN    81°C</p> <p>EXH GAS SEN    0.06V</p> </div>	<p><b>PERFORM DIAGNOSTIC TEST MODE II (SELF-DIAGNOSTIC REQUIRED)</b></p>

## TROUBLE DIAGNOSES

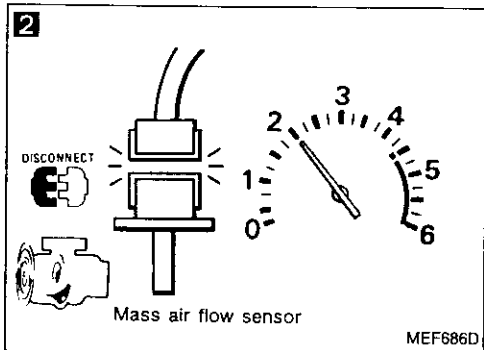
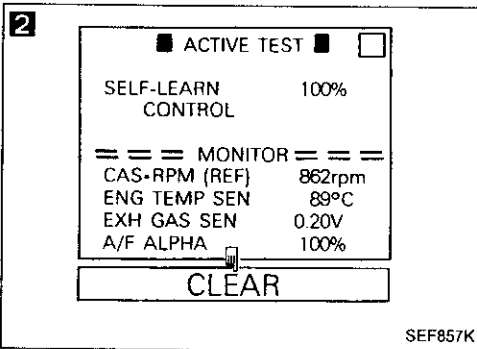
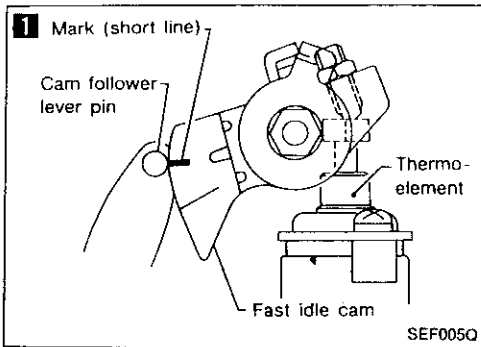

### Diagnostic Procedure 1 — Symptom — High Idling after Warm-up

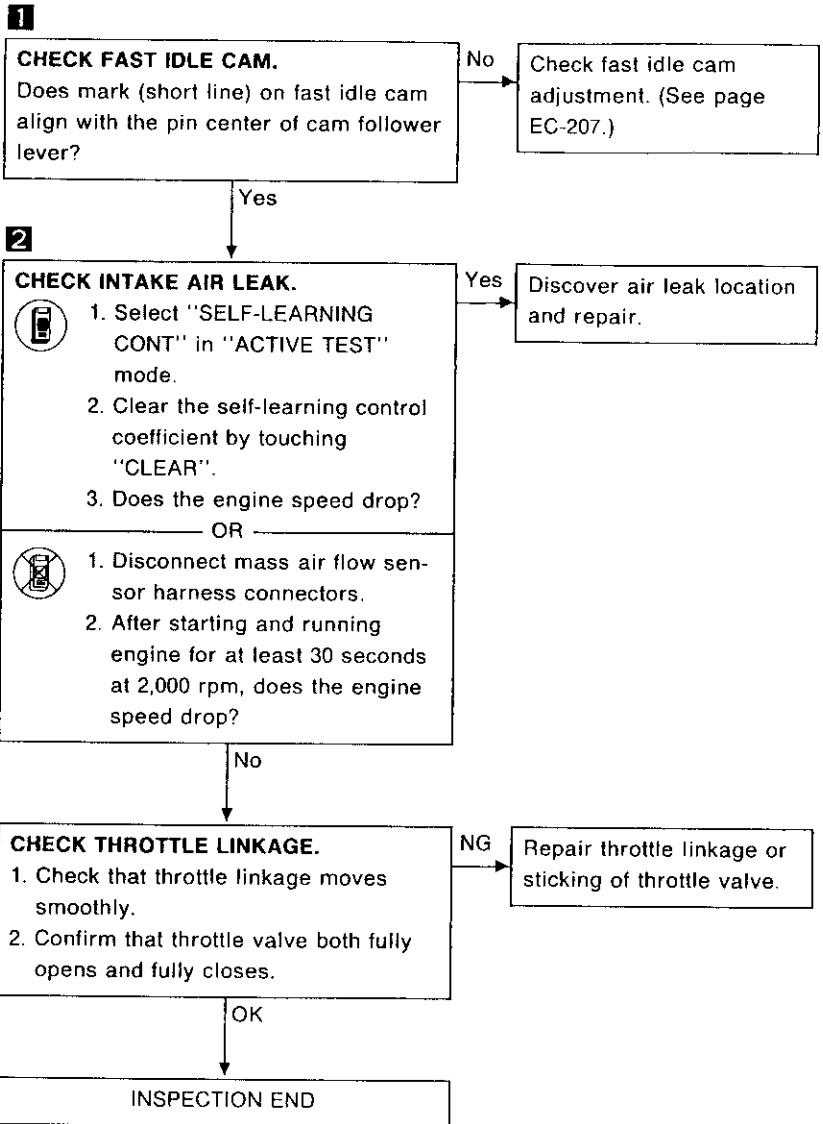

# TROUBLE DIAGNOSES

## Diagnostic Procedure 2 — Symptom — Hunting

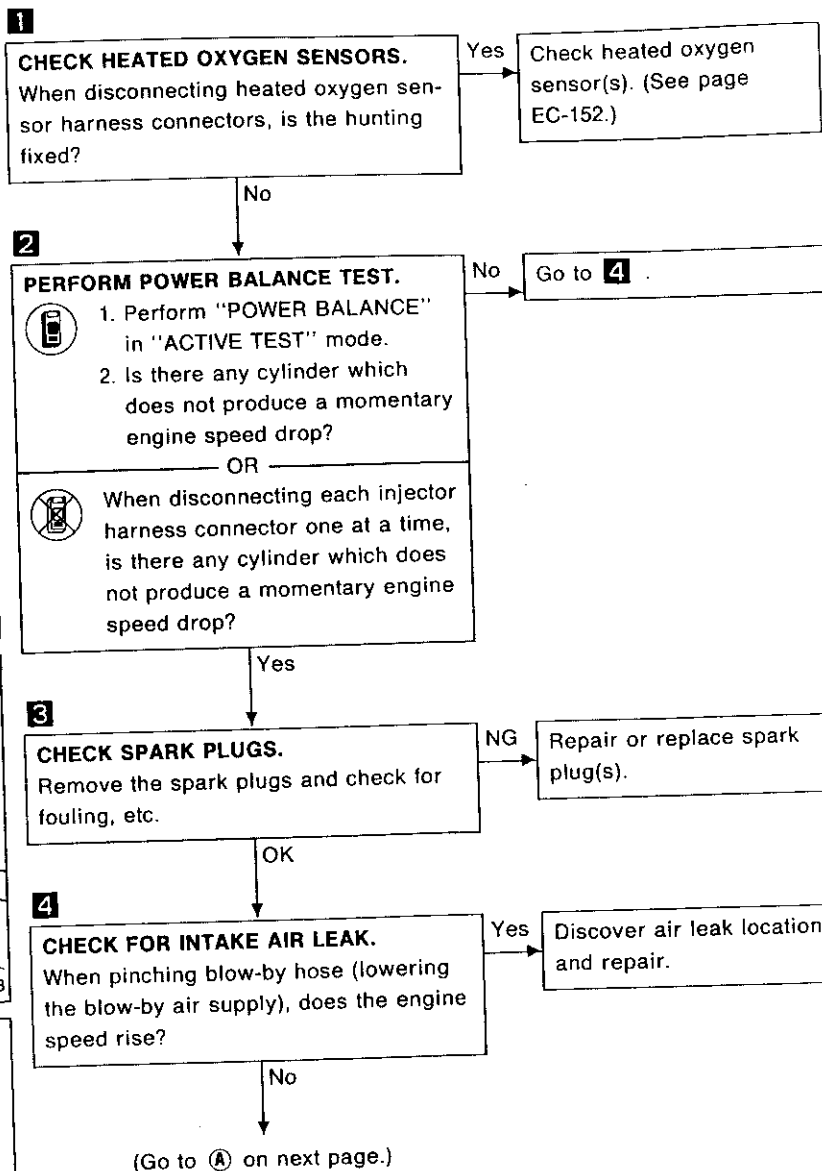
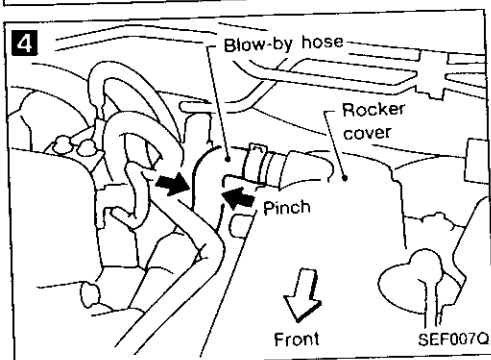
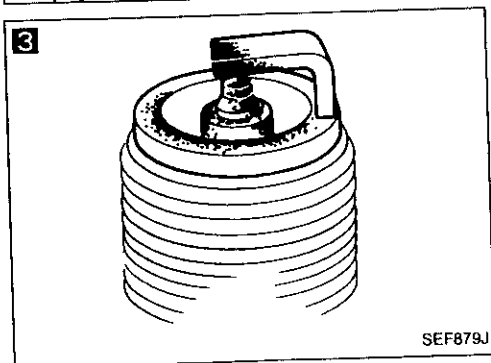
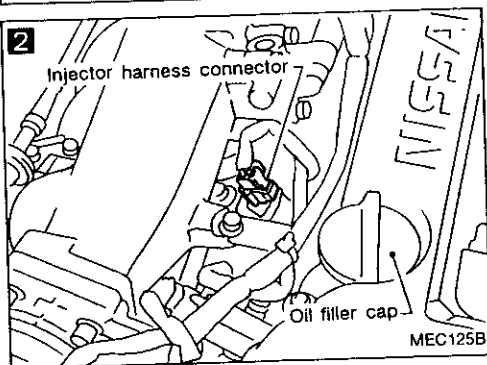
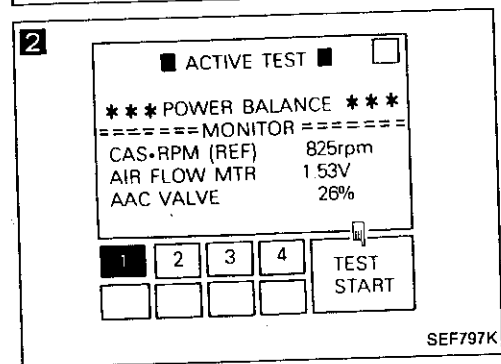
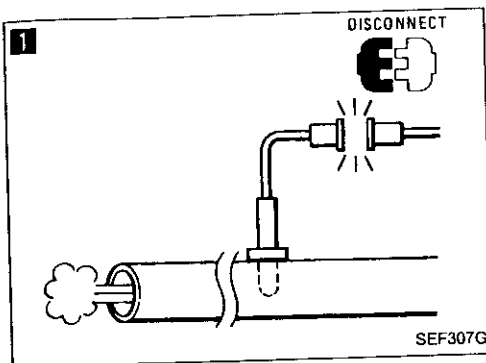

GI  
MA  
EM  
LC  
EC  
FE  
CL  
MT  
AT  
PD  
FA  
RA  
BR  
ST  
RS  
BT  
HA  
EL  
IDX



## TROUBLE DIAGNOSES

### Diagnostic Procedure 2 — Symptom — Hunting (Cont'd)

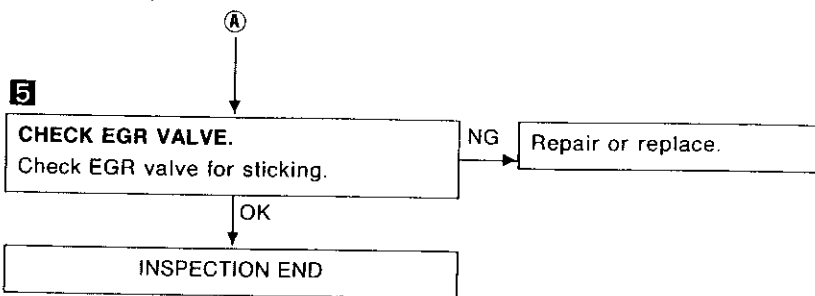
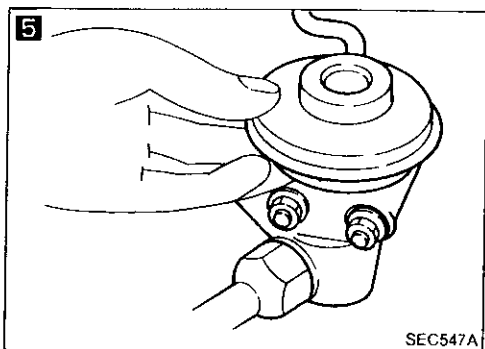

### Diagnostic Procedure 3 — Symptom — Unstable Idle

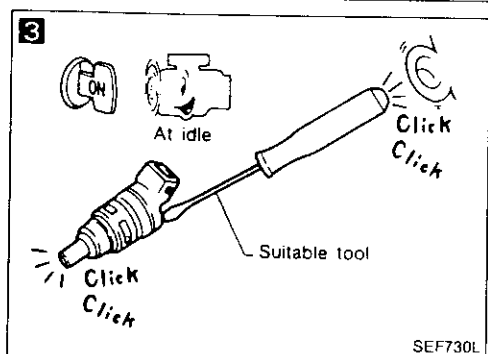
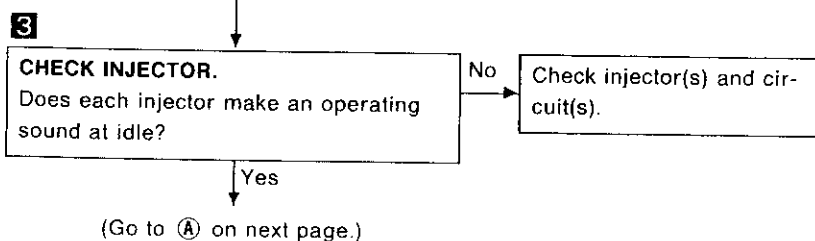
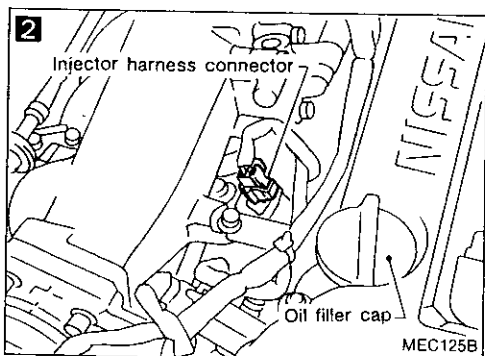
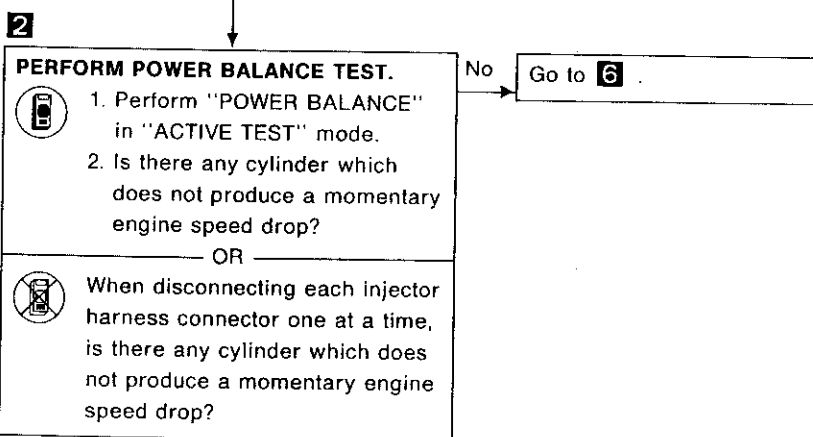
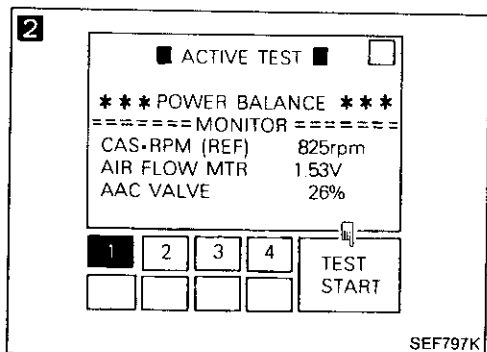
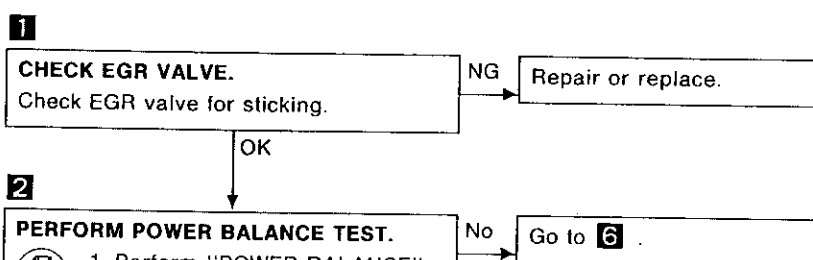
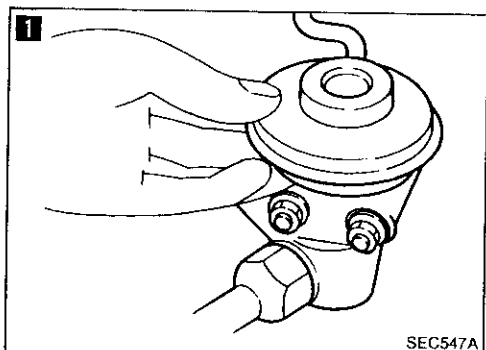

# TROUBLE DIAGNOSES

## Diagnostic Procedure 3 — Symptom — Unstable Idle (Cont'd)

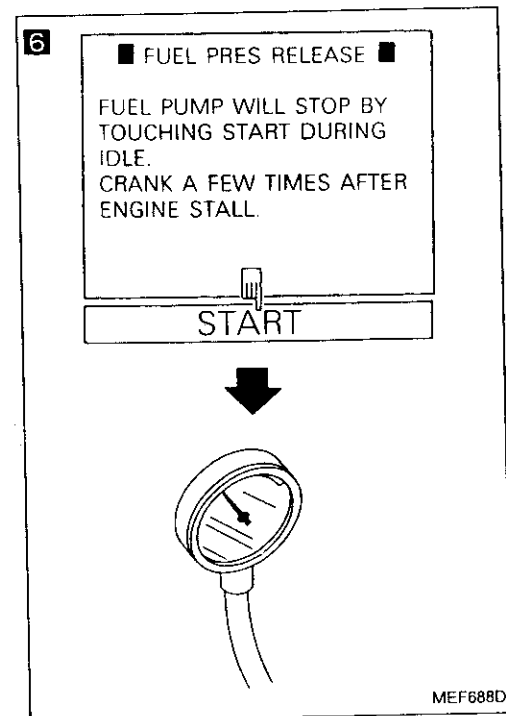
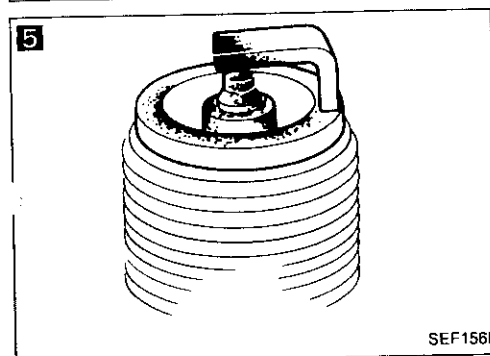
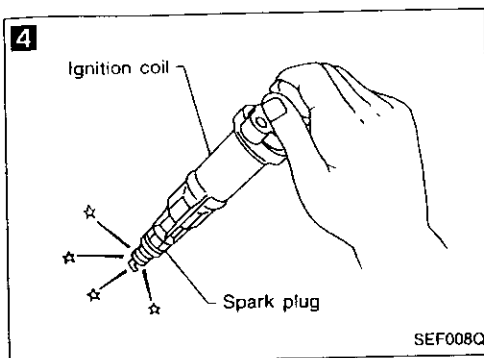

**4**

**CHECK IGNITION SPARK.**

1. Disconnect ignition coil assembly from rocker cover.
2. Connect a known good spark plug to the ignition coil assembly.
3. Place end of spark plug against a suitable ground and crank engine.
4. Check for spark.

NG → Check ignition coil, power transistor unit and their circuits. (See page EC-120, 202.)

**5**

**CHECK SPARK PLUGS.**

Remove the spark plugs and check for fouling, etc.

NG → Repair or replace spark plug(s).

**6**

**CHECK FUEL PRESSURE.**

1. Perform "FUEL PRESSURE RELEASE" in "WORK SUPPORT" mode in order to release fuel pressure to zero.
2. Install fuel pressure gauge and check fuel pressure.  
**At idle approx. 245 kPa (2.45 bar, 2.5 kg/cm<sup>2</sup>, 36 psi)**

OR

1. Release fuel pressure to zero. (Refer to page EC-208.)
2. Install fuel pressure gauge and check fuel pressure.

NG → Check fuel pump and circuit.

OK → (Go to ② on next page.)

GI  
VA  
EM  
LC  
EC  
FE  
CL  
MT  
AT  
PD  
FA  
RA  
BR  
ST  
RS  
BT  
HA  
EL  
DX

## TROUBLE DIAGNOSES

### Diagnostic Procedure 3 — Symptom — Unstable Idle (Cont'd)

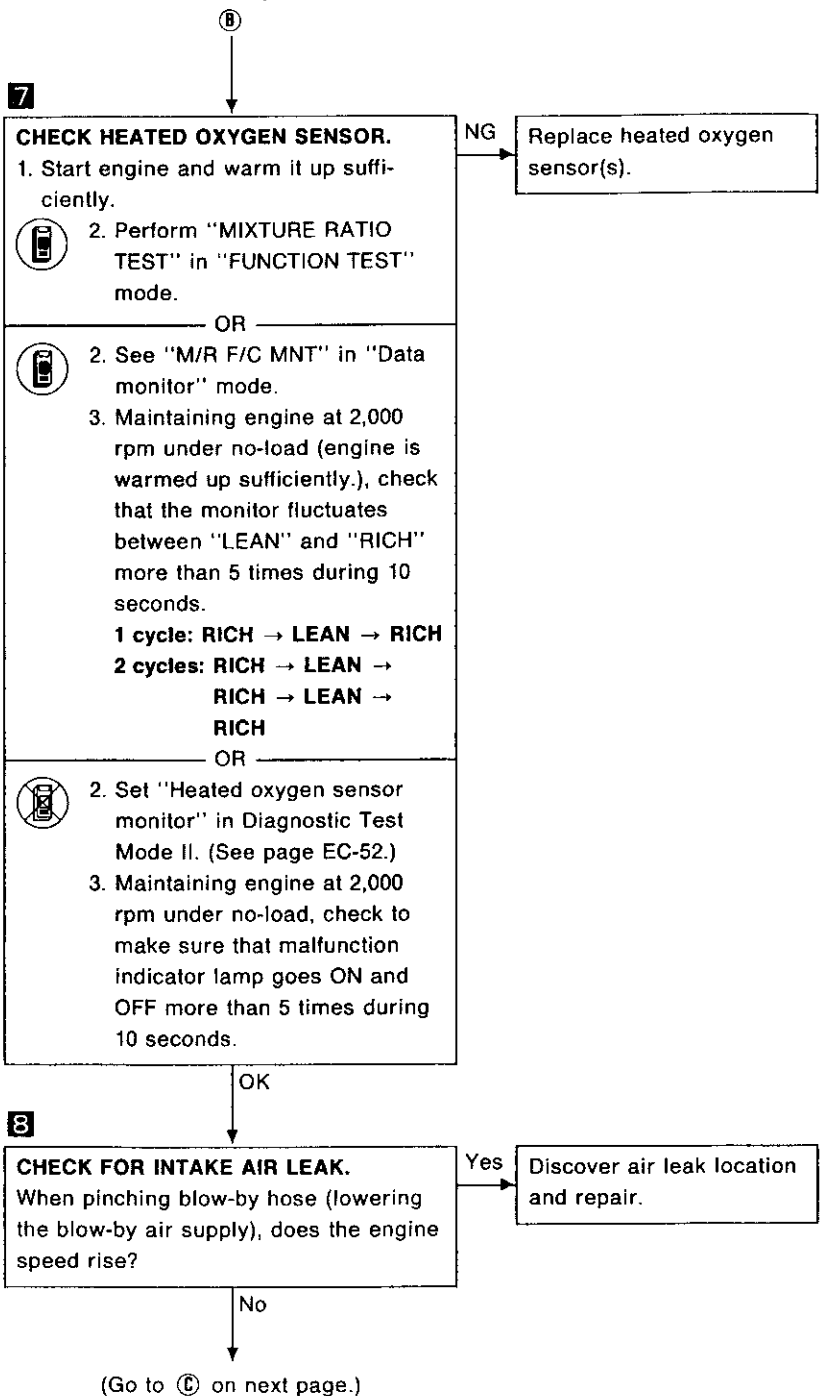
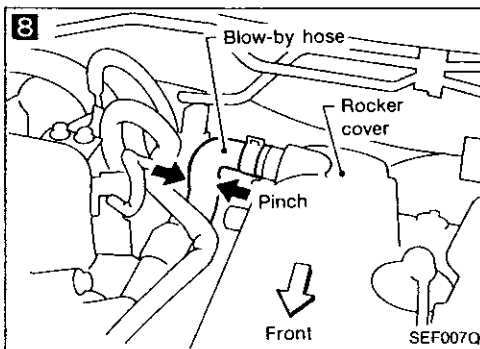
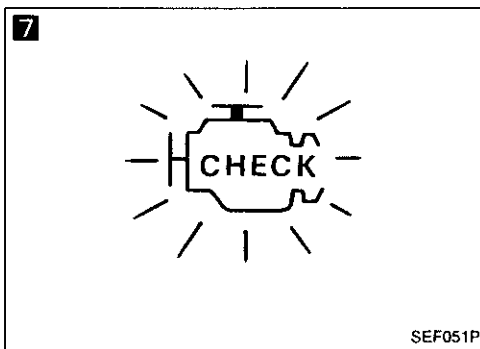
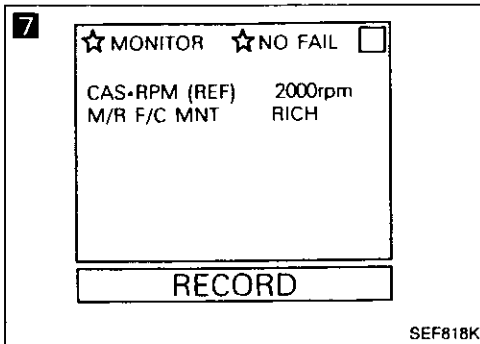
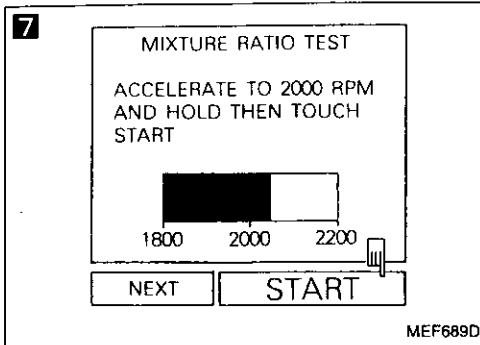

# TROUBLE DIAGNOSES

## Diagnostic Procedure 3 — Symptom — Unstable Idle (Cont'd)

**9**

■ IGN TIMING ADJ ■ □

--- CONDITION SETTING ---

IGN/T FEEDBACK HOLD

===== MONITOR =====

CAS-RPM (REF)	762rpm
IGN TIMING	15BTDC
IDLE POSITION	ON

SEF786K

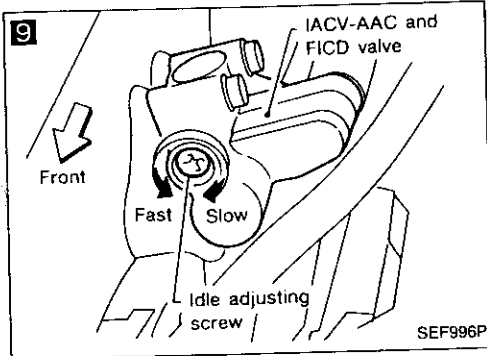

**10**

**COMPRESSION PRESSURE**

SEF309G

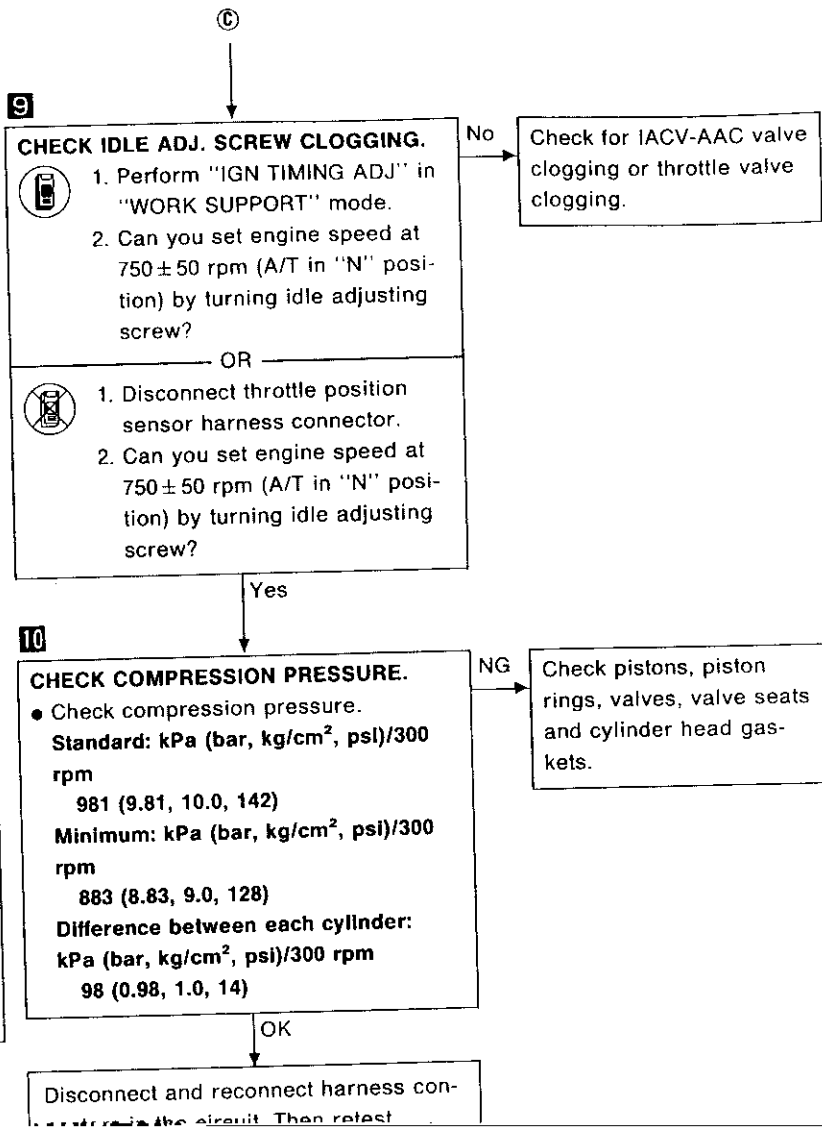

GI

WA

EM

LC

EC

FE

CL

MT

AT

PD

FA

RA

BR

## TROUBLE DIAGNOSES

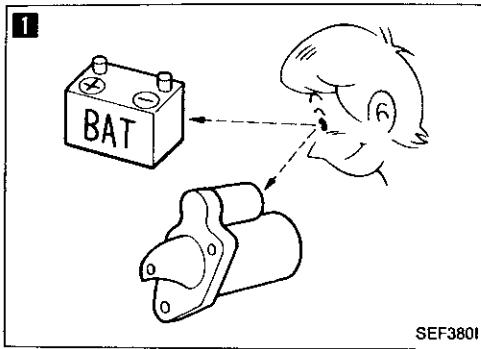

SEF3801

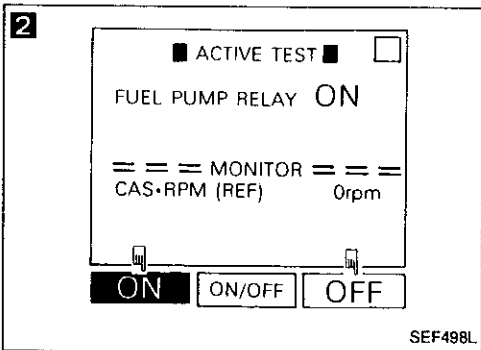

SEF498L

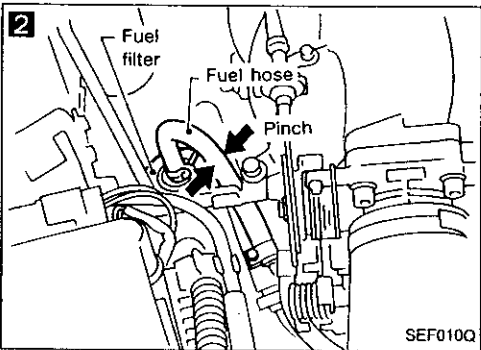

SEF010Q

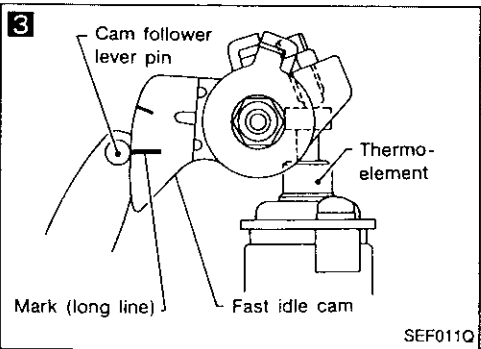

SEF011Q

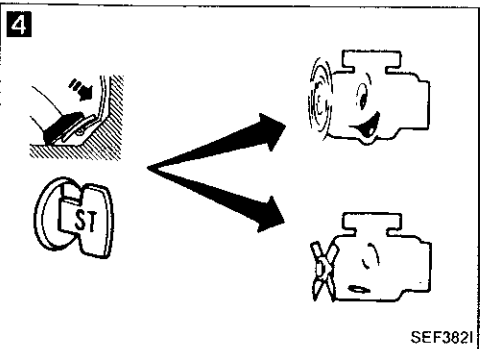

SEF3821

### Diagnostic Procedure 4 — Symptom — Hard to Start or Impossible to Start when the Engine is Cold

**1**

**CHECK BATTERY AND STARTER.**  
Check battery and starter condition.  
(Refer to EL section.)

NG

Repair or replace.

OK

**2**

**CHECK FUEL PRESSURE.**



1. Turn ignition switch "ON".
2. Perform "FUEL PUMP RELAY" in "ACTIVE TEST" mode.
3. Pinch fuel feed hose with fingers.

**Is fuel pressure pulsation felt on the fuel feed hose?**

OR



1. Pinch fuel feed hose with fingers.
2. When cranking the engine, is there any pressure on the fuel feed hose?

No

Check fuel pump and circuit. (See page EC-159.)

Yes

**3**

**CHECK FAST IDLE CAM.**

When the engine is cold, does mark (long line) on fast idle cam align with the pin center of cam follower lever?

No

Check fast idle cam adjustment. (See page EC-207.)

Yes

**4**

**CHECK IACV-AAC VALVE.**

When pressing accelerator pedal fully, can you start the engine.

Yes

Check IACV-AAC valve and circuit. (See page EC-169.)

No

(Go to **A** on next page.)

## TROUBLE DIAGNOSES

### Diagnostic Procedure 4 — Symptom — Hard to Start or Impossible to Start when the Engine is Cold (Cont'd)

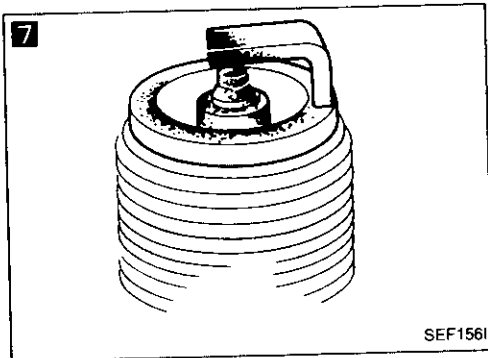
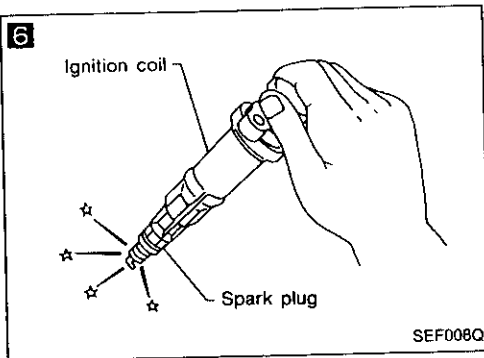
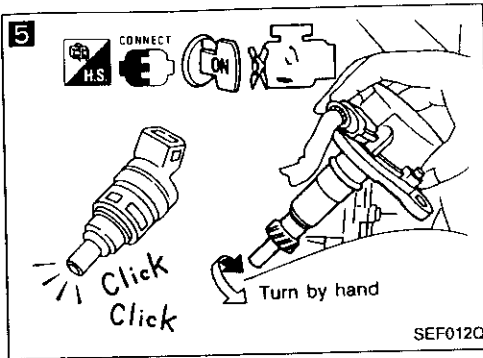

**5**

**CHECK INJECTOR.**

1. Remove camshaft position sensor from engine. (Harness connector should remain connected.)
2. Disconnect power transistor harness connector.
3. Turn ignition switch ON. (Do not start engine.)
4. When rotating camshaft position sensor shaft, does each injector make an operating sound?

No → Check injector(s) and circuit(s).

Yes

**6**

**CHECK IGNITION SPARK.**

1. Disconnect ignition coil assembly from rocker cover.
2. Connect a known good spark plug to the ignition coil assembly.
3. Place end of spark plug against a suitable ground and crank engine.
4. Check for spark.

NG → Check ignition coil, power transistor unit and their circuits. (See page EC-120, 202.)

OK

**7**

**CHECK SPARK PLUGS.**  
Remove the spark plugs and check for fouling, etc.

NG → Repair or replace spark plug(s).

OK

**CHECK ECM POWER SUPPLY AND GROUND CIRCUIT.**  
Refer to page EC-105.

NG → Repair or replace.

OK

Disconnect and reconnect harness connectors in the circuit. Then retest.

Trouble is not fixed.

GI

MA

EM

LC

EC

FE

CL

MT

AT

PD

FA

RA

BR

ST

RS

## TROUBLE DIAGNOSES

### Diagnostic Procedure 5 — Symptom — Hard to Start or Impossible to Start when the Engine is Hot

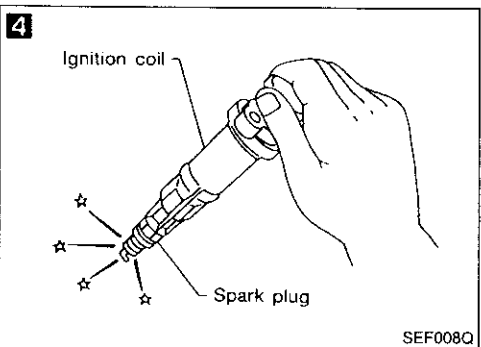
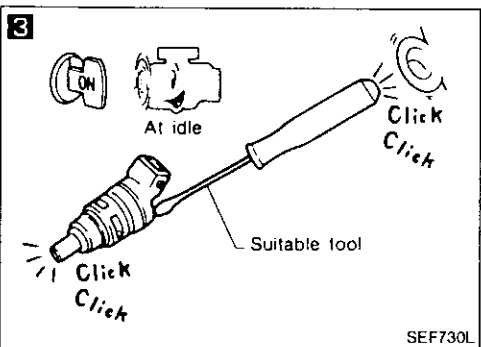
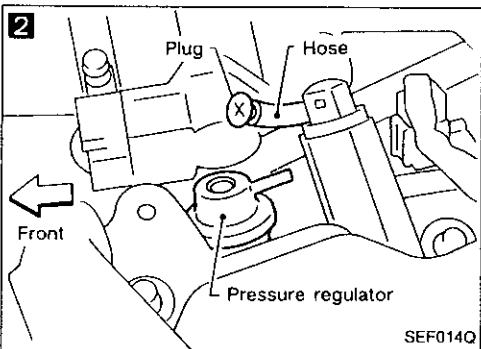
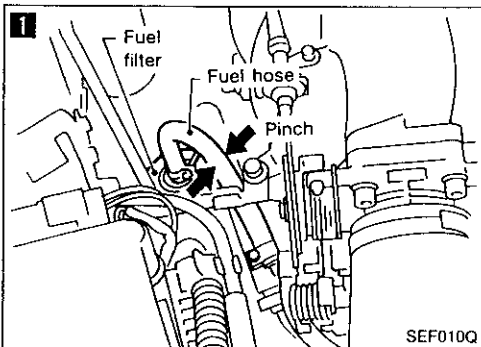
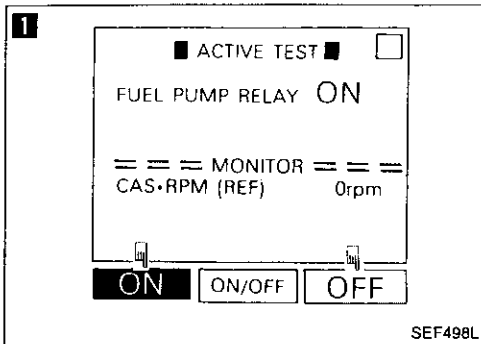

**1** **CHECK FUEL PRESSURE.**

1. Turn ignition switch "ON".
2. Perform "FUEL PUMP RELAY" in "ACTIVE TEST" mode.
3. Pinch fuel feed hose with fingers.

No → Check fuel pump and circuit. (See page EC-159.)

**Is fuel pressure pulsation felt on the fuel feed hose?**

OR

1. Pinch fuel feed hose with fingers.
2. When cranking the engine, is there any pressure on the fuel feed hose?

Yes

**2** **CHECK FUEL VAPOR.**

1. Disconnect fuel pressure regulator vacuum hose and plug hose.
2. Can you start engine?

Yes → Check fuel properties.

No

**3** **CHECK INJECTOR.**

Does each injector make an operating sound at idle?

No → Check injector(s) and circuit(s).

Yes

**4** **CHECK IGNITION SPARK.**

1. Disconnect ignition coil assembly from rocker cover.
2. Connect a known good spark plug to the ignition coil assembly.
3. Place end of spark plug against a suitable ground and crank engine.
4. Check for spark.

NG → Check ignition coil, power transistor unit and circuits. (See page EC-120, 202.)

OK

(Go to (A) on next page.)

## TROUBLE DIAGNOSES

### Diagnostic Procedure 5 — Symptom — Hard to Start or Impossible to Start when the Engine is Hot (Cont'd)

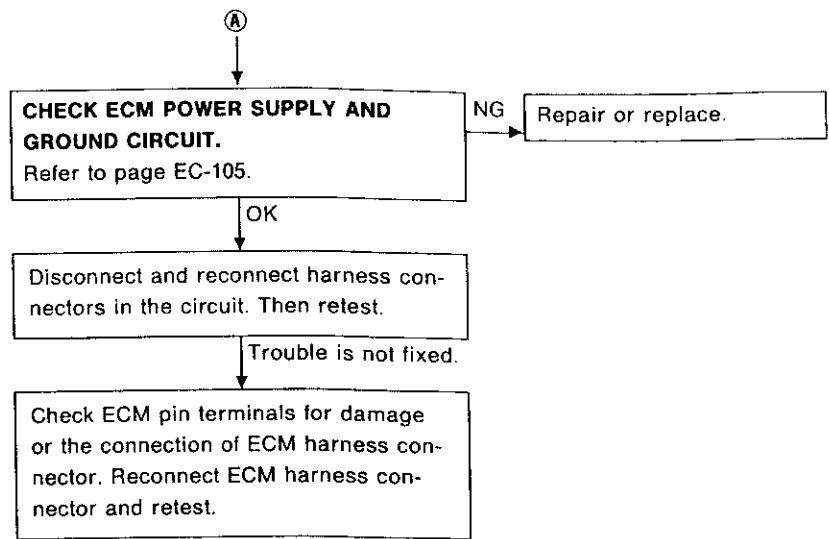

GF

MA

EM

LC

**EC**

FE

CL

MT

AT

PD

FA

RA

BR

ST

RS

BT

HA

EL

DX



## TROUBLE DIAGNOSES

### Diagnostic Procedure 6 — Symptom — Hard to Start or Impossible to Start under Normal Conditions

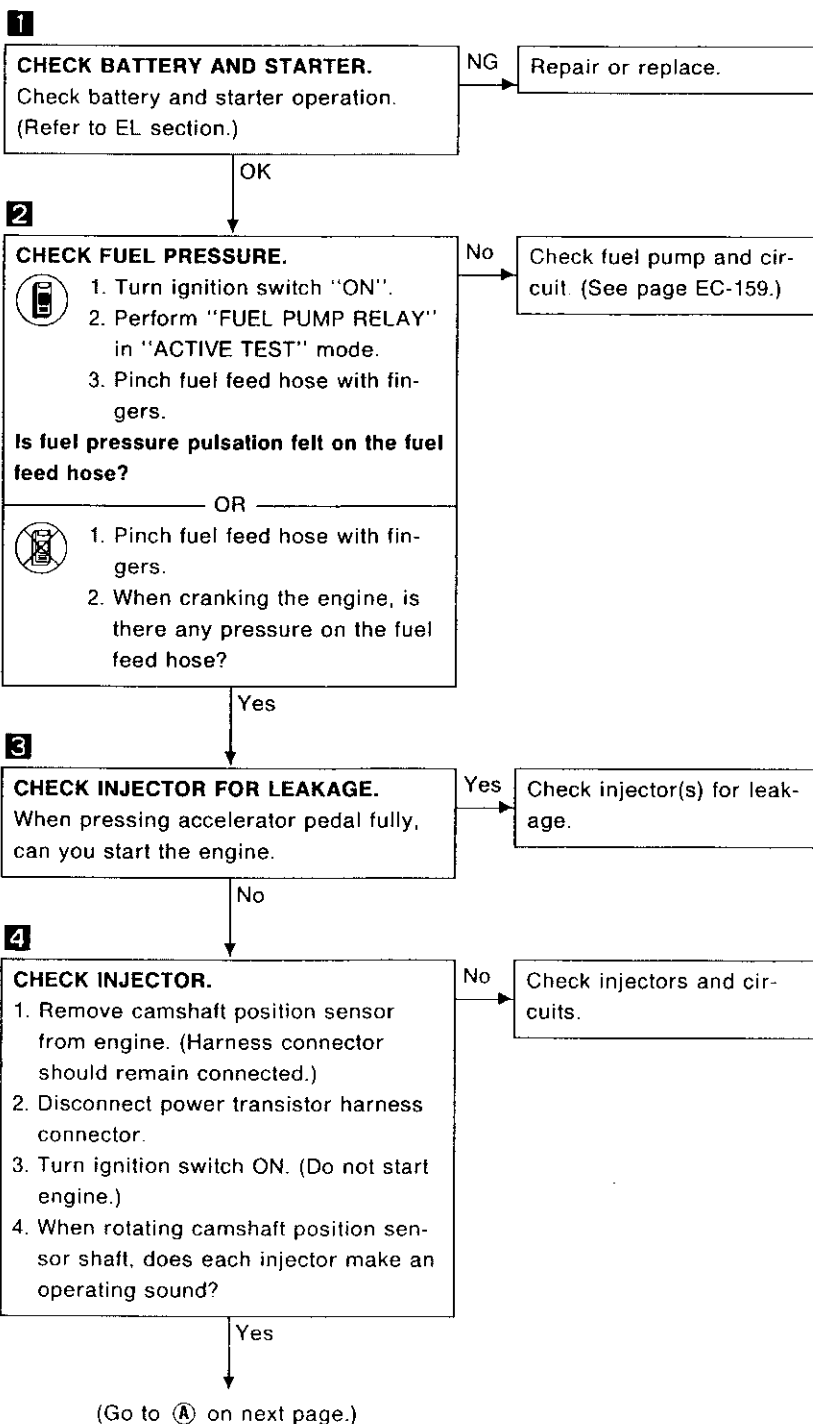
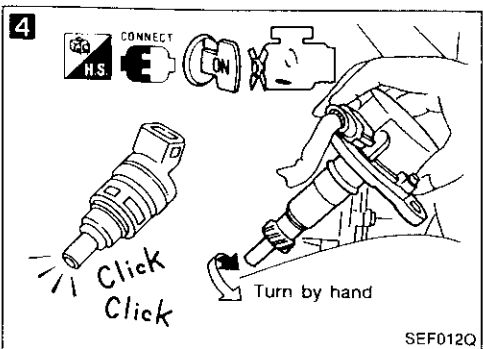
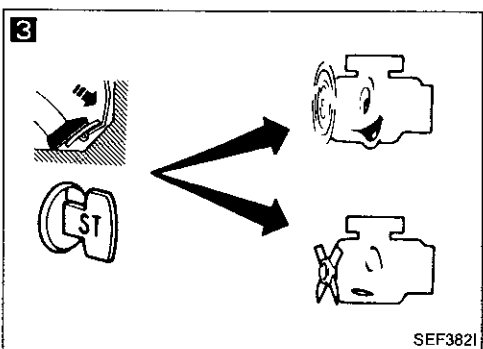
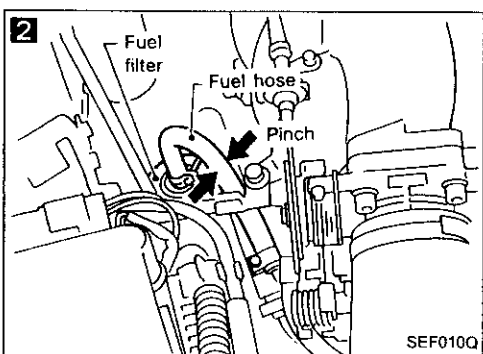
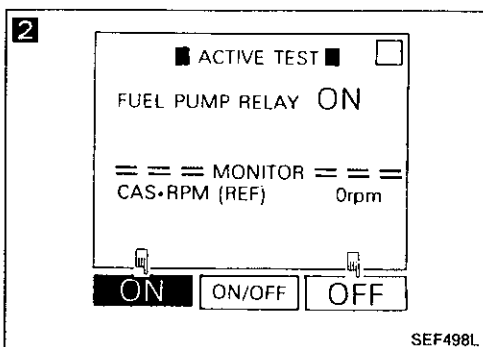
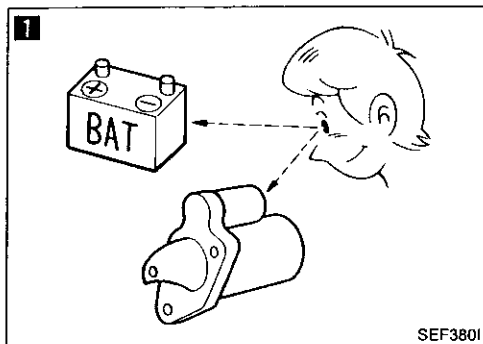

## TROUBLE DIAGNOSES

### Diagnostic Procedure 6 — Symptom — Hard to Start or Impossible to Start under Normal Conditions (Cont'd)

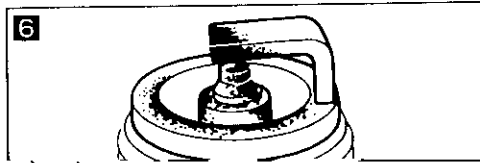
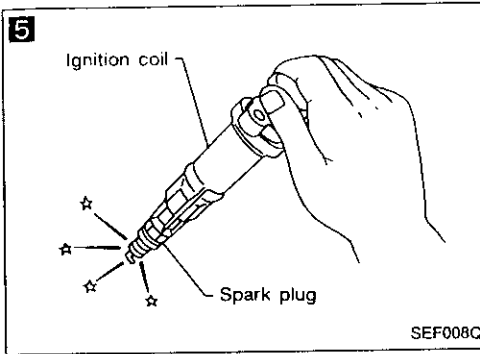

- 5
- CHECK IGNITION SPARK.**
1. Disconnect ignition coil assembly from rocker cover.
  2. Connect a known good spark plug to the ignition coil assembly.
  3. Place end of spark plug against a suitable ground and crank engine.
  4. Check for spark.

NG → Check ignition coil, power transistor unit and circuits. (See page EC-120, 202.)

OK

6

GI

MA

EM

LC

EC

## TROUBLE DIAGNOSES

### Diagnostic Procedure 7 — Symptom — Hesitation when the Engine is Hot

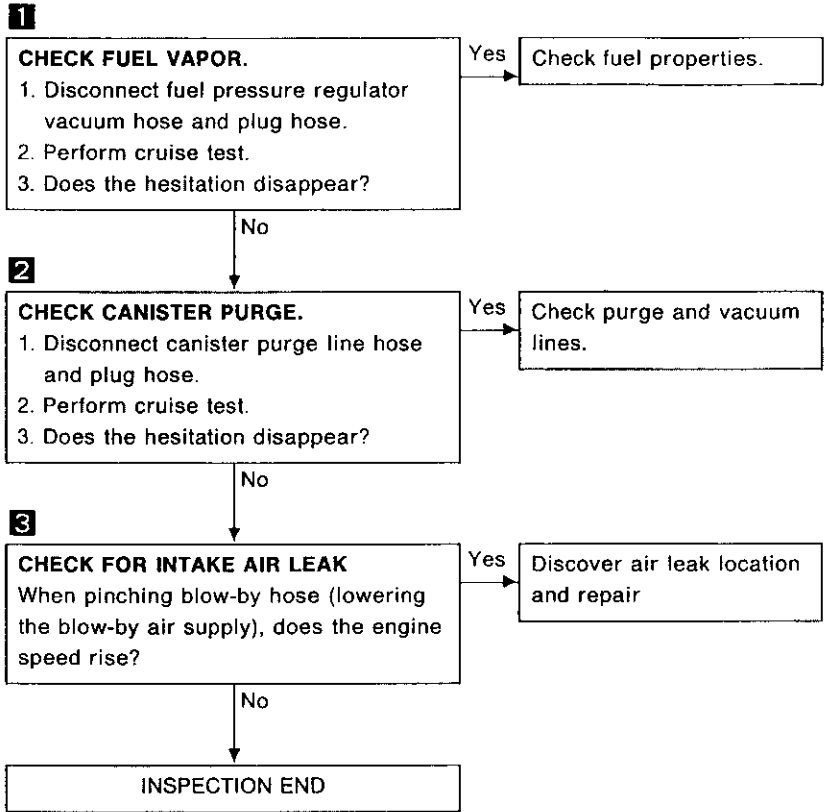
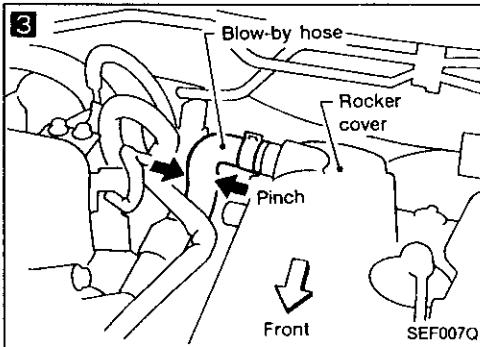
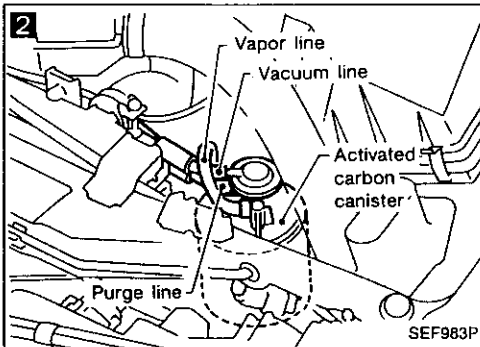
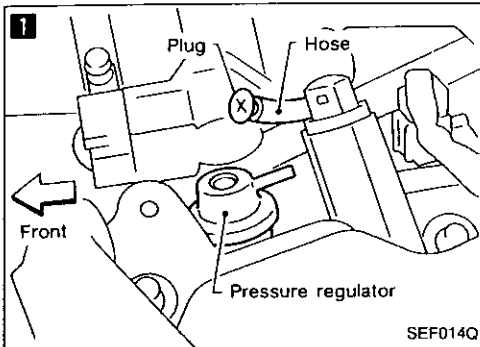

# TROUBLE DIAGNOSES

## Diagnostic Procedure 8 — Symptom — Hesitation when the Engine is Cold

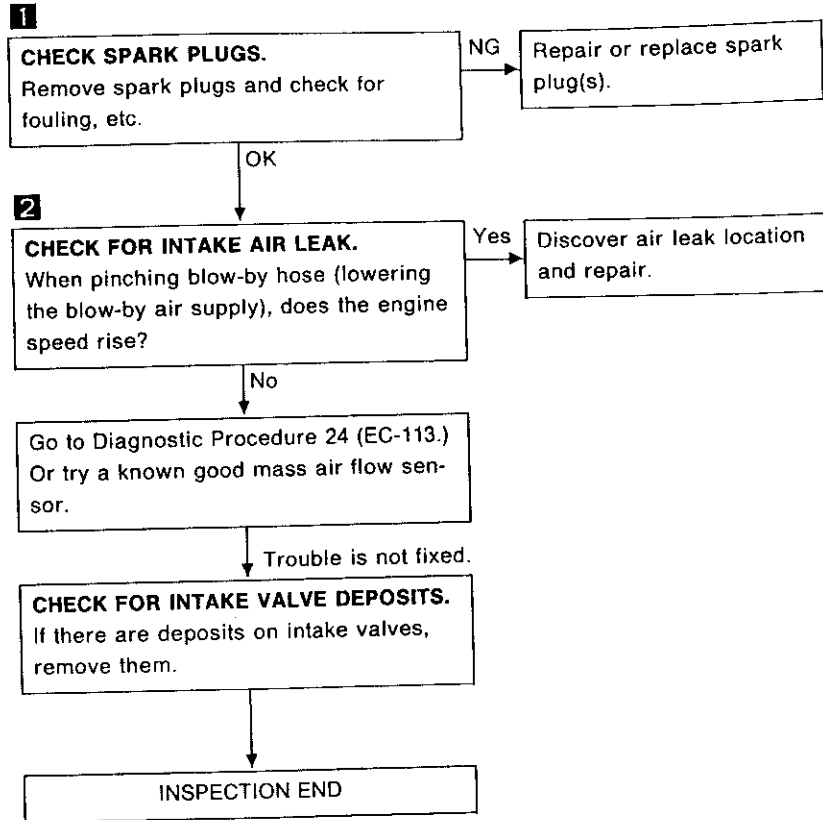
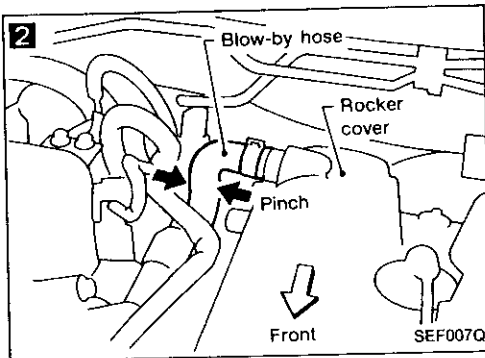
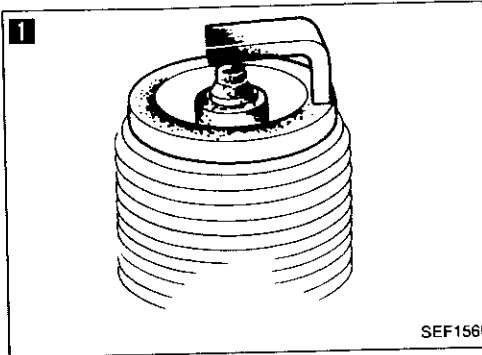

GF  
MA  
EM  
LC  
EC  
FE  
CL  
MT  
AT  
PD  
FA  
RA  
BR  
ST  
RS  
BT  
HA  
EL  
IDX

# TROUBLE DIAGNOSES

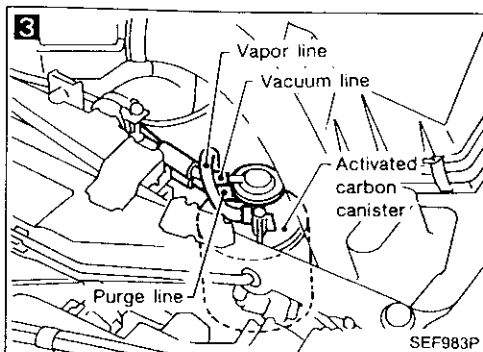
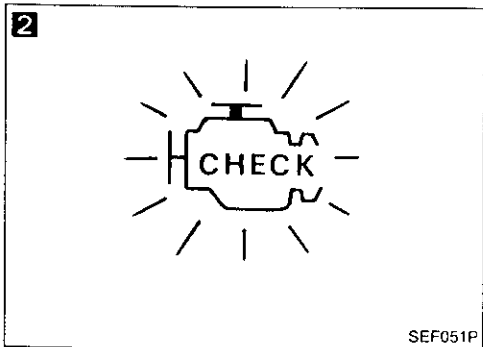
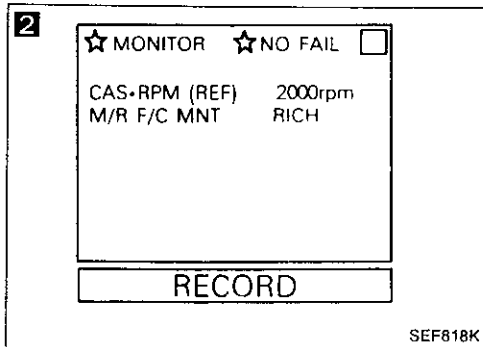
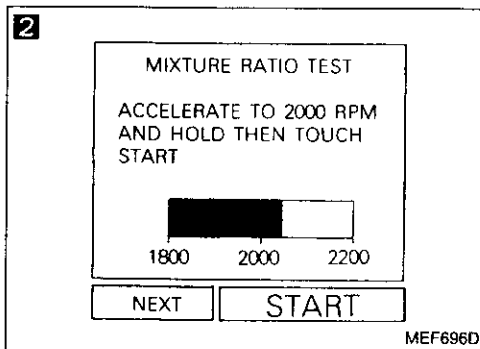
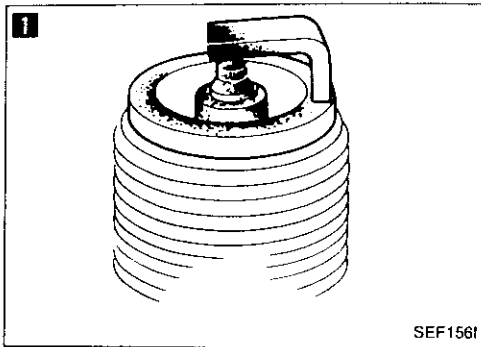

## Diagnostic Procedure 9 — Symptom — Hesitation under Normal Conditions

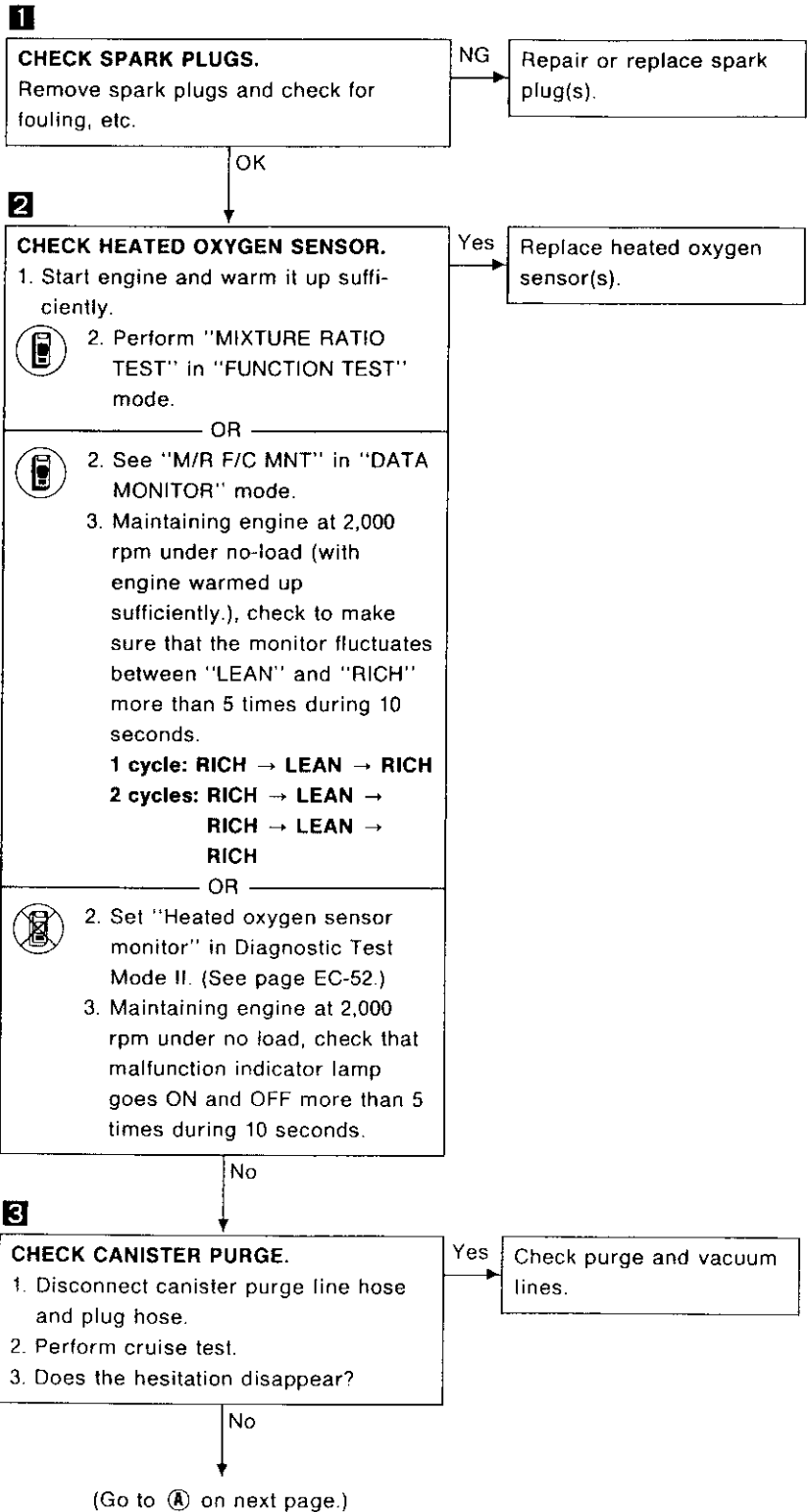

## TROUBLE DIAGNOSES

### Diagnostic Procedure 9 — Symptom — Hesitation under Normal Conditions (Cont'd)

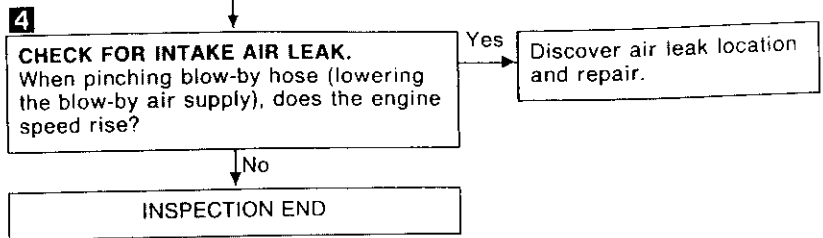
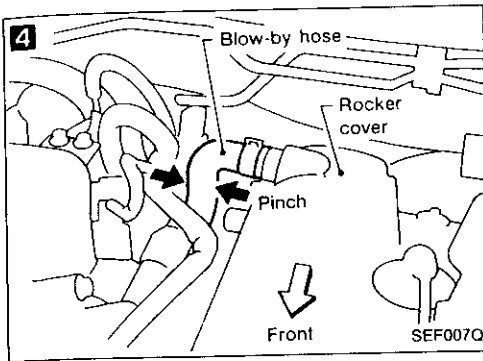

### Diagnostic Procedure 10 — Symptom — Engine Stalls when Turning

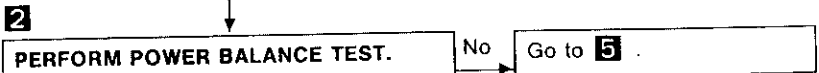
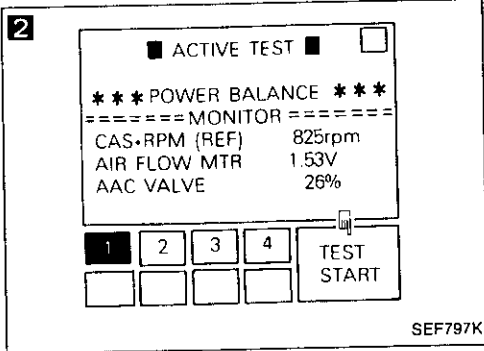
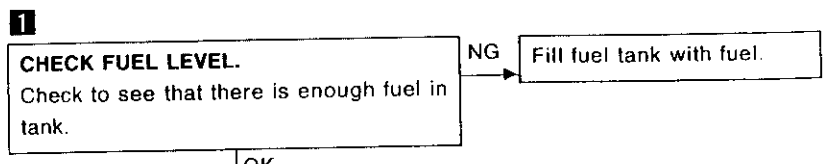
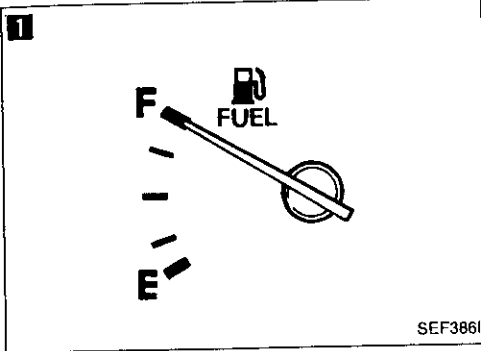

GI

MA

EM

LC

EC

FE

CL

MT

AT

PD

FA





RA

BR

ST

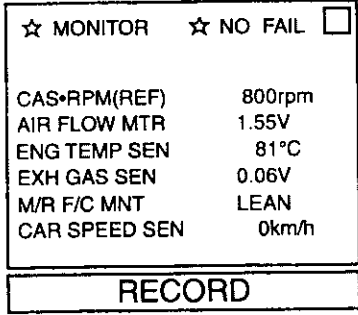
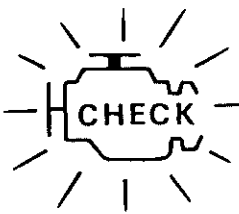
# TROUBLE DIAGNOSES

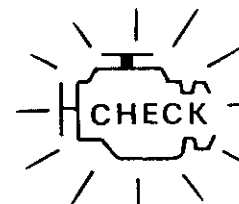
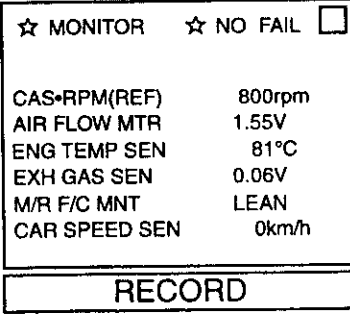
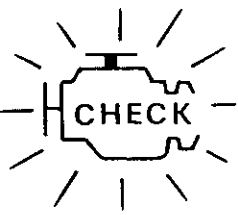
## How to Execute On-board Diagnostic System in Diagnostic Test Mode II (Cont'd)

Detected items	Display Diagnostic trouble code No.	How to perform diagnostic test mode II (Self-diagnostic results) judgement	
		Illustration	Method
Throttle position sensor circuit	43	 <p style="text-align: right; font-size: small;">SEF004Q</p>  <p style="text-align: right; font-size: small;">SEF051P</p>	<p><b>PERFORM DIAGNOSTIC TEST MODE II (SELF-DIAGNOSTIC RESULTS).</b></p> <ol style="list-style-type: none"> <li>1) Jack up drive wheels</li> <li>2) Start engine.</li> <li>3) Shift to a suitable gear position (Except "P" or "N" position), and run engine at vehicle speed of 5 km/h (3 MPH) or higher for at least 10 seconds.</li> </ol> <p> 4) Select "DATA MONITOR" mode with CONSULT. ☆ <b>NO FAIL</b></p> <p style="text-align: center;">OR</p> <p> 4) Turn ignition switch "OFF" and then "ON".</p> <p>5) Perform diagnostic test mode II (Self-diagnostic results) with ECM. <b>Malfunction indicator lamp displays diagnostic trouble code No. 43.</b></p>
Signal circuit from A/T control unit to ECM	54	 <p style="text-align: right; font-size: small;">SEF004Q</p>  <p style="text-align: right; font-size: small;">SEF051P</p>	<p><b>PERFORM DIAGNOSTIC TEST MODE II (SELF-DIAGNOSTIC RESULTS).</b></p> <ol style="list-style-type: none"> <li>1) Turn ignition switch "ON" or start engine.</li> <li>2) Select "DATA MONITOR" mode with CONSULT. ☆ <b>NO FAIL</b></li> </ol> <p style="text-align: center;">OR</p> <p> 2) Perform diagnostic test mode II (Self-diagnostic results) with ECM. <b>Malfunction indicator lamp displays diagnostic trouble code No. 55.</b></p>

GI  
 MA  
 EM  
 LC  
 EC  
 FE  
 CL  
 MT  
 AT  
 PD  
 FA  
 RA  
 BR  
 ST  
 RS  
 BT  
 HA  
 EL  
 DX

## TROUBLE DIAGNOSES

### Diagnostic Procedure 10 — Symptom — Engine Stalls when Turning (Cont'd)

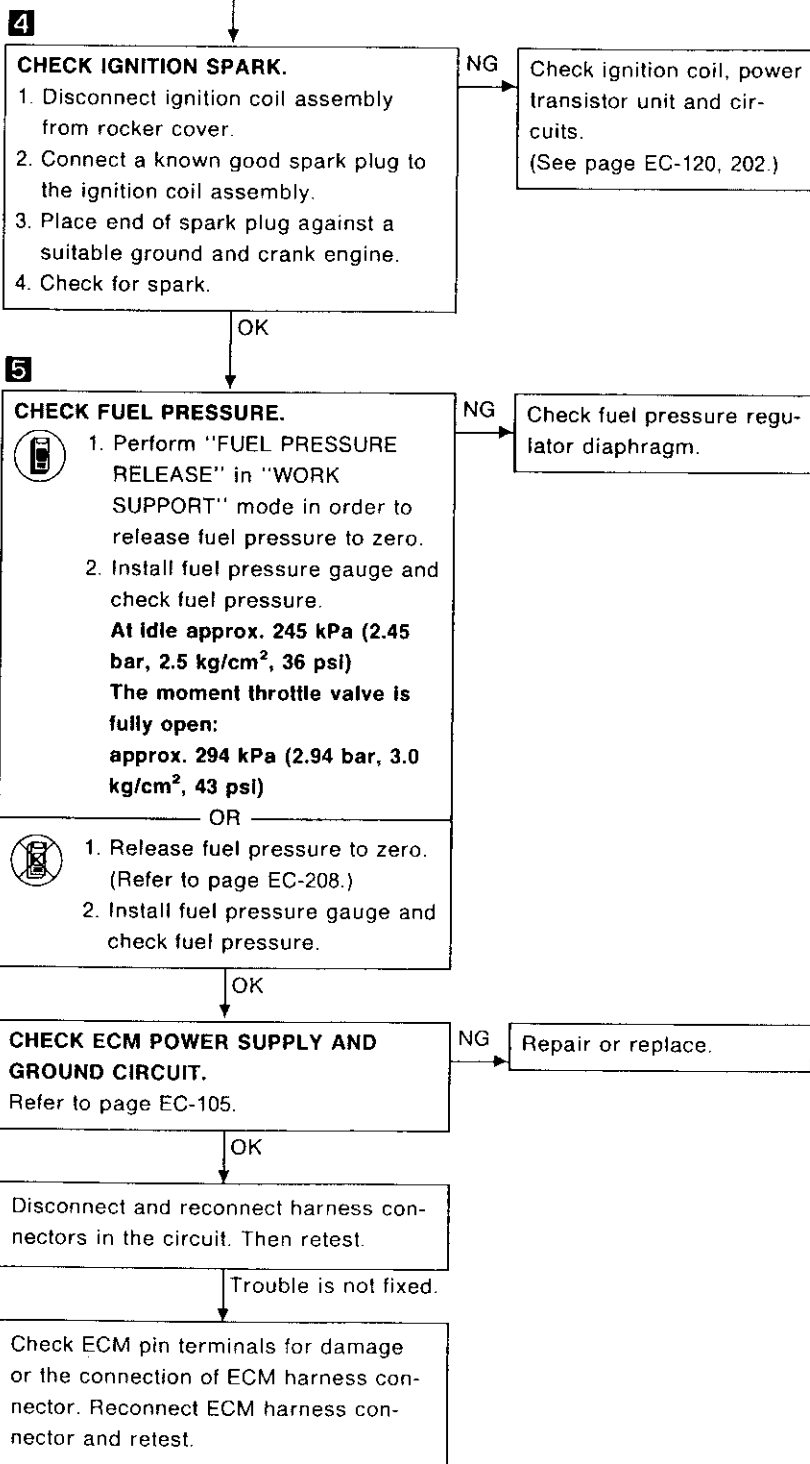
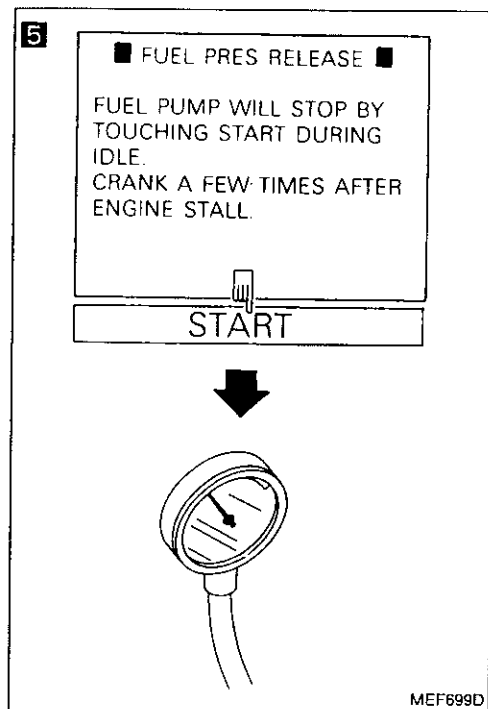
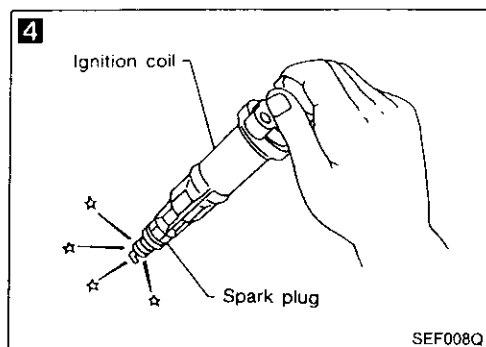



# TROUBLE DIAGNOSES

## Diagnostic Procedure 11 — Symptom — Engine Stalls when the Engine is Hot

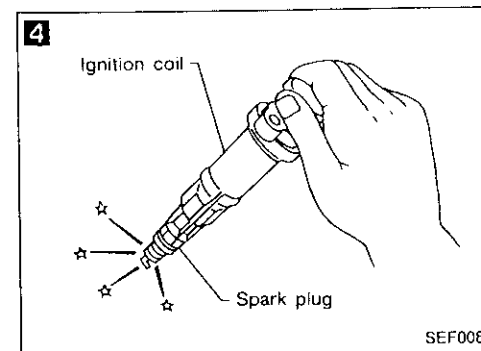
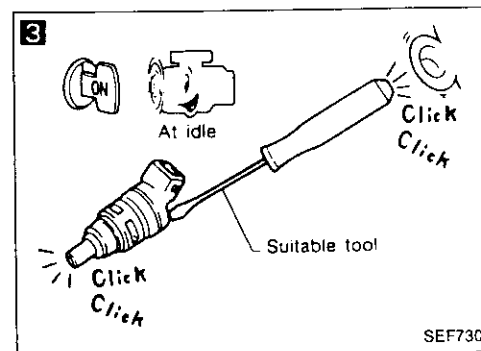
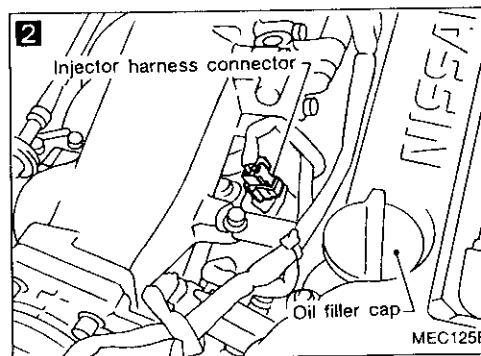
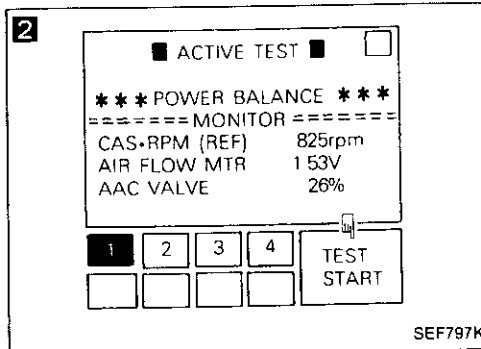
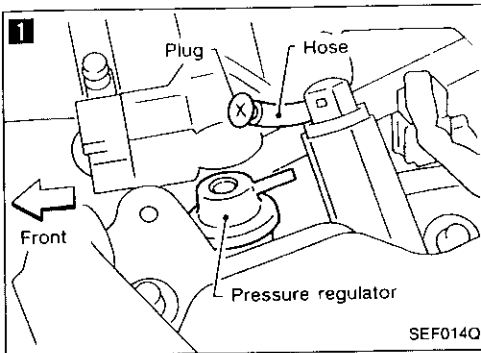

**1**

**CHECK FUEL VAPOR.**

1. Disconnect fuel pressure regulator vacuum hose and plug hose.
2. Perform cruise test.
3. Does the engine stall disappear?

Yes → Check fuel properties.

No

**2**

**PERFORM POWER BALANCE TEST.**

1. Perform "POWER BALANCE" in "ACTIVE TEST" mode.
2. Is there any cylinder which does not produce a momentary engine speed drop?

OR

When disconnecting each injector harness connector one at a time, is there any cylinder which does not produce a momentary engine speed drop?

No → Go to **5**.

Yes

**3**

**CHECK INJECTOR.**

Does each injector make an operating sound at idle?

No → Check injector(s) and circuit(s).

Yes

**4**

**CHECK IGNITION SPARK.**

1. Disconnect ignition coil assembly from rocker cover.
2. Connect a known good spark plug to the ignition coil assembly.
3. Place end of spark plug against a suitable ground and crank engine.
4. Check for spark.

NG → Check ignition coil, power transistor unit and their circuits. (See page EC-120, 202.)

OK

(Go to **A** on next page.)

GI

WA

EM

LC

EC

FE

CL

MT

AT

PD

EA

BA

BR

ST

RS

RT

HA

EL

DX

## TROUBLE DIAGNOSES

### Diagnostic Procedure 11 — Symptom — Engine Stalls when the Engine is Hot (Cont'd)

**5** ■ FUEL PRES RELEASE ■

FUEL PUMP WILL STOP BY TOUCHING START DURING IDLE.  
CRANK A FEW TIMES AFTER ENGINE STALL

START



MEF699D

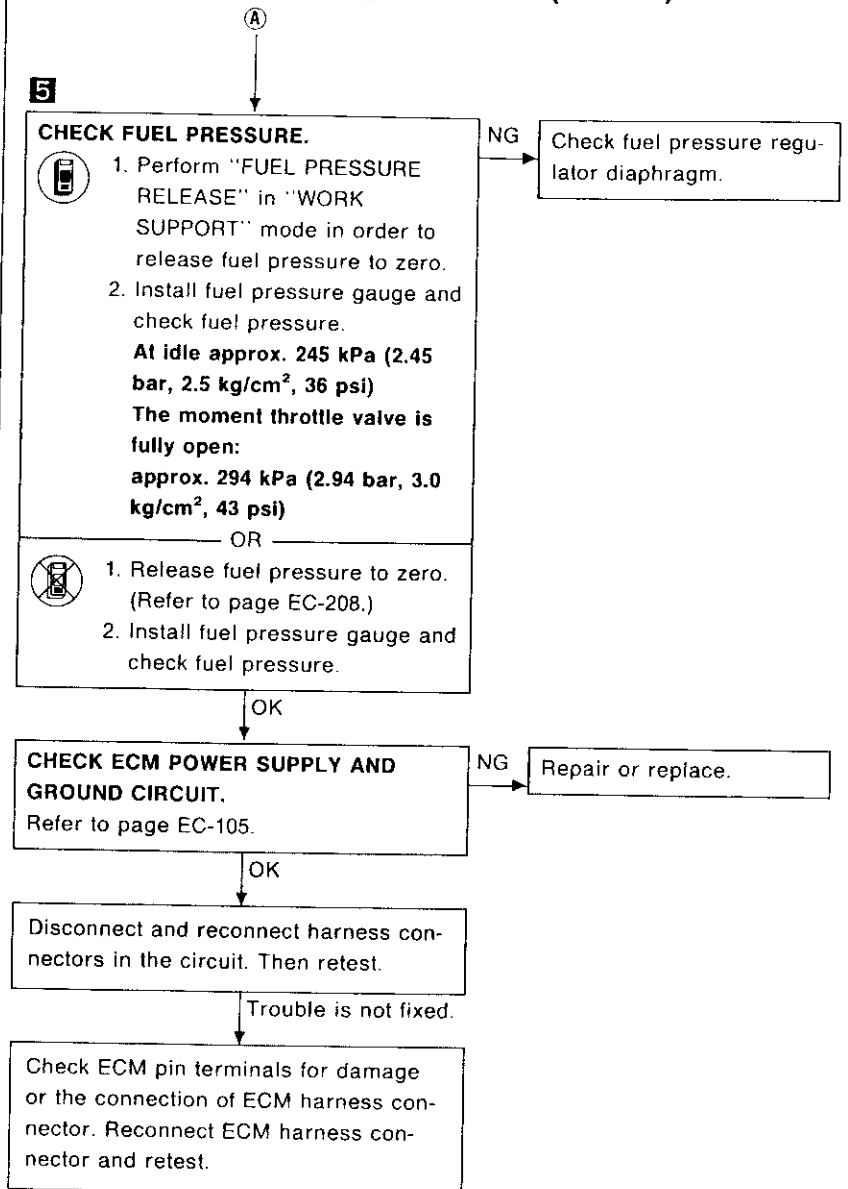

# TROUBLE DIAGNOSES

## Diagnostic Procedure 12 — Symptom — Engine Stalls when the Engine is Cold

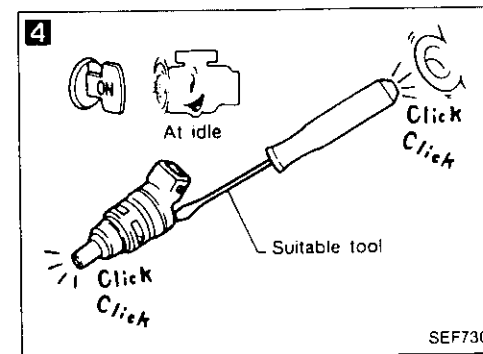
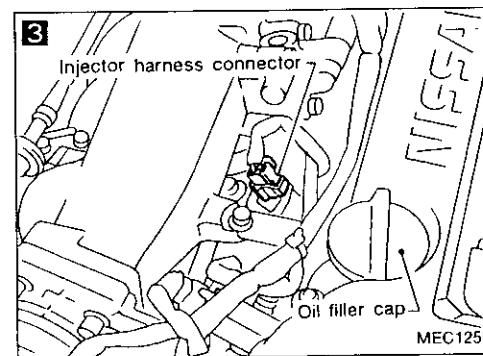
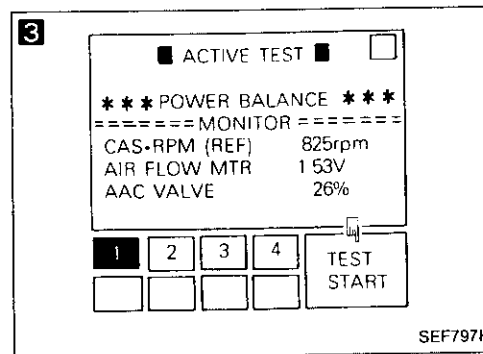
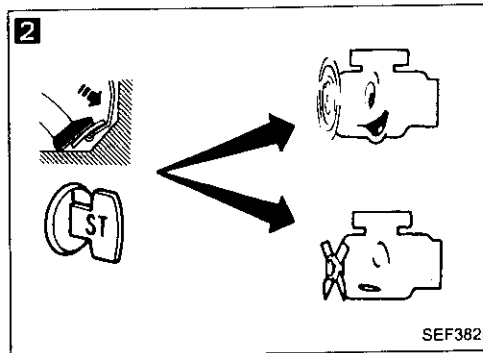
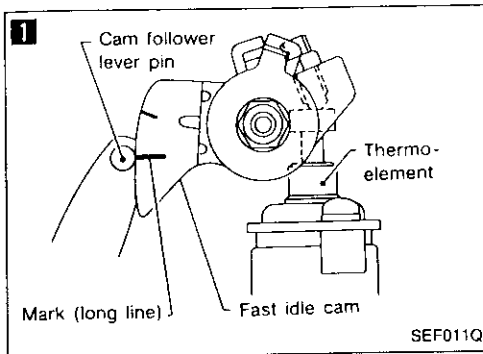

**1**  
**CHECK FAST IDLE CAM.**  
When the engine is cold, does fast idle cam keep cam follower lever in position?

No → Check fast idle cam adjustment. (See page EC-207.)

Yes  
**2**  
**CHECK IACV-AAC VALVE.**  
When the engine is cold, can you start the engine when pressing accelerator pedal fully?

Yes → Check IACV-AAC valve and circuits. (See page EC-169.)

No  
**3**  
**PERFORM POWER BALANCE TEST.**  
1. Perform "POWER BALANCE" in "ACTIVE TEST" mode.  
2. Is there any cylinder which does not produce a momentary engine speed drop?

NG → Go to **7**.

OR  
When disconnecting each injector harness connector one at a time, is there any cylinder which does not produce a momentary engine speed drop?

OK  
**4**  
**CHECK INJECTOR.**  
Does each injector make an operating sound at idle?

NG → Check injector(s) and circuit(s).

OK  
(Go to **A** on next page.)

ST  
WA  
EM  
LC  
EC  
FR  
CL  
MT  
AT  
FD  
EA  
FA  
ED  
ST  
RS  
BT  
HA  
EL  
DX

## TROUBLE DIAGNOSES

### Diagnostic Procedure 12 — Symptom — Engine Stalls when the Engine is Cold (Cont'd)

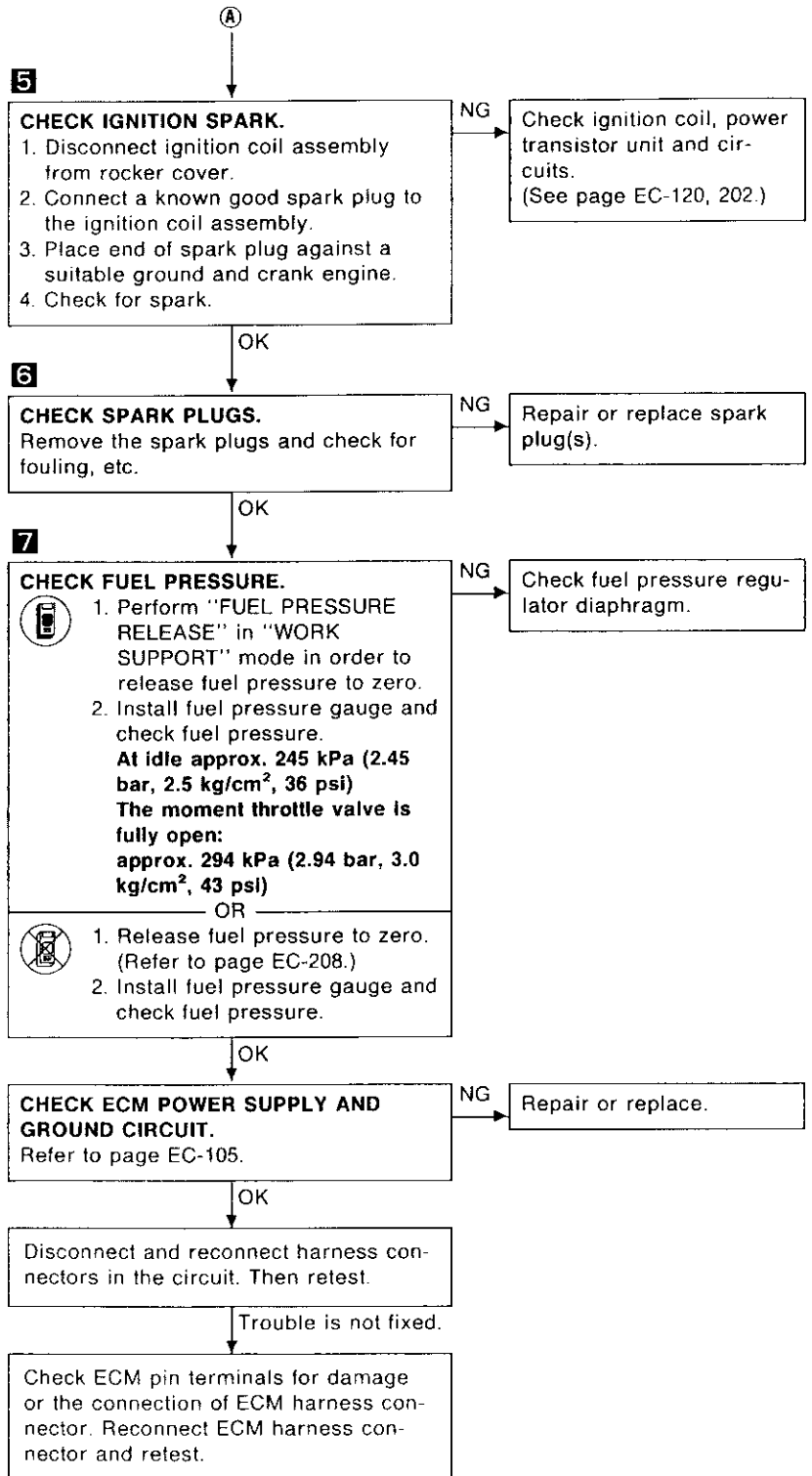
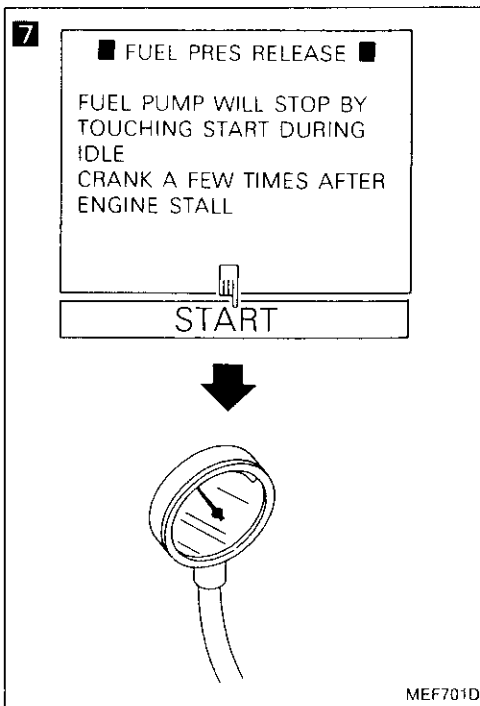
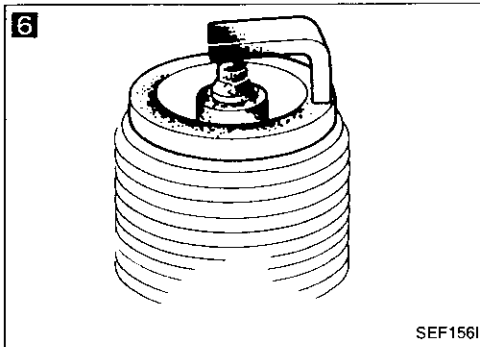
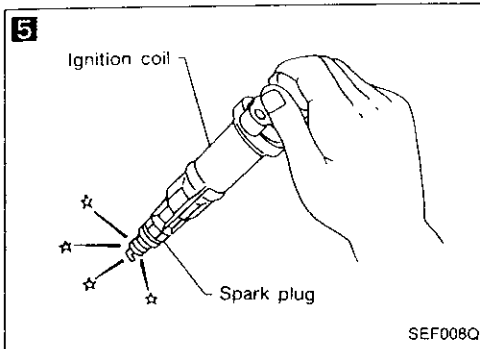

# TROUBLE DIAGNOSES

## Diagnostic Procedure 13 — Symptom — Engine Stalls when Stepping on the Accelerator Momentarily

**1**

■ AAC VALVE SYSTEM ■

LET ENGINE IDLE THEN TOUCH START (A/C SW·LIGHT SW OFF)

NEXT START

SEF196L

**1**

■ ACTIVE TEST ■

AAC/V OPENING 34%

== MONITOR ==

CAS·RPM (REF) 875rpm

AIR FLOW MTR 1.60V

ENG TEMP SEN 83°C

Qu UP DWN Qd

SEF319L

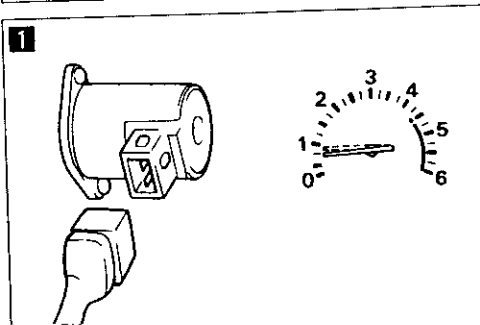

**1**

**CHECK IACV-AAC VALVE.**

1. Start engine and warm it up sufficiently.

2. Perform "AAC/V SYSTEM" or "IACV-AAC/V SYSTEM" in "FUNCTION TEST" mode.

OR

1. Select "AAC/V OPENING" or "IACV-AAC/V OPENING" in "ACTIVE TEST" mode.

2. When touching "Qu" and "Qd", does the engine speed change according to the percent of IACV-AAC valve opening?

OR

When disconnecting IACV-AAC valve harness connector, does the engine speed drop?

No → Check IACV-AAC valve and circuit. (See page EC-169.)

**2**

**PERFORM POWER BALANCE TEST.**

1. Perform "POWER BALANCE" in "ACTIVE TEST" mode.

2. Is there any cylinder which

No → Go to **5**

CI  
MA  
EM  
LC  
EC  
FE  
CL  
MT  
AT  
PD  
FA  
RA

## TROUBLE DIAGNOSES

### Diagnostic Procedure 13 — Symptom — Engine

#### Stalls when Stepping on the Accelerator Momentarily (Cont'd)

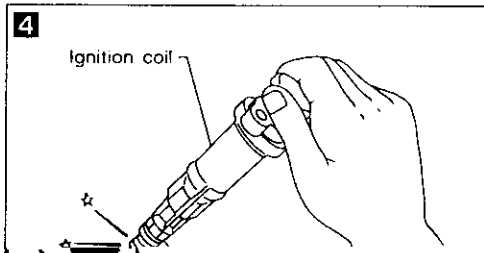
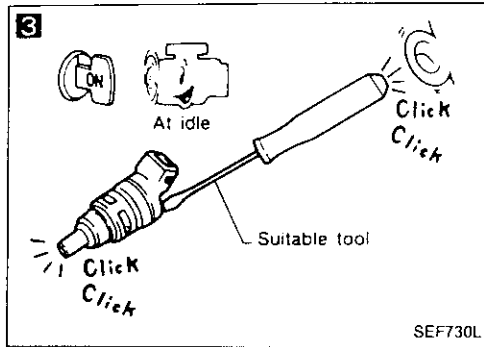

**4**

#### CHECK IGNITION SPARK.

1. Disconnect ignition coil assembly from rocker cover.
2. Connect a known good spark plug to the ignition coil assembly.
3. Place end of spark plug against an earth point with engine cranking.
4. Check for spark.

NG

Check ignition coil, power transistor unit and their circuits. (See page EC-120, 202.)

OK

**5**

#### CHECK FUEL PRESSURE.

1. Perform "FUEL PRESSURE RELEASE" in "WORK SUPPORT" mode in order to

NG

Check fuel pressure regulator diaphragm.

# TROUBLE DIAGNOSES

## Diagnostic Procedure 14 — Symptom — Engine Stalls after Decelerating

**1**

■ AAC VALVE SYSTEM ■

LET ENGINE IDLE  
THEN  
TOUCH START  
(A/C SW-LIGHT SW OFF)

NEXT START

SEF196L

**1**

■ ACTIVE TEST ■

AAC/V OPENING 34%

=== MONITOR ===

CAS-RPM (REF) 875rpm  
AIR FLOW MTR 1 60V  
ENG TEMP SEN 83°C

Qu UP DWN Qd

SEF319L

**1**

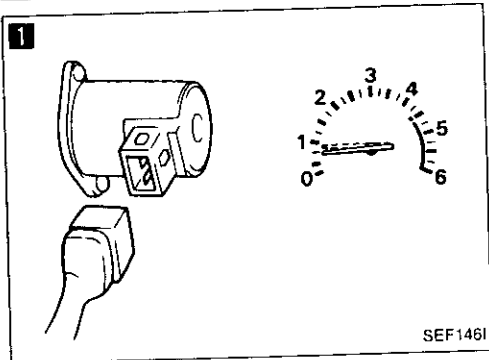

SEF146I

**2**

■ IGN TIMING ADJ ■

--- CONDITION SETTING ---

IGN/T FEEDBACK: HOLD

===== MONITOR =====

CAS-RPM (REF) 762rpm  
IGN TIMING 15BTDC  
IDLE POSITION ON

SEF786K

**2**

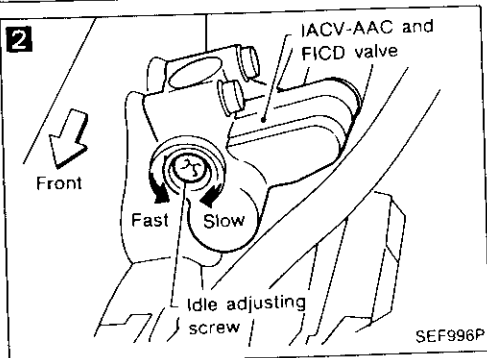

IACV-AAC and FICD valve

Front

Fast Slow

Idle adjusting screw

SEF996P

**1**

**CHECK IACV-AAC VALVE.**

1. Start engine and warm it up sufficiently.

2. Perform "AAC/V SYSTEM" or "IACV-AAC/V SYSTEM" in "FUNCTION TEST" mode.

No → Check IACV-AAC valve and circuit. (See page EC-169.)

OR

1. Select "AAC/V OPENING" or "IACV-AAC/V OPENING" in "ACTIVE TEST" mode.

2. When touching "Qu" and "Qd", does the engine speed change according to the percent of IACV-AAC valve opening?

OR

When disconnecting IACV-AAC valve harness connector, does the engine speed drop?

Yes

**2**

**CHECK IDLE ADJ. SCREW CLOGGING.**

1. Perform "IGN TIMING ADJ" in "WORK SUPPORT" mode.

2. Can you set engine speed at  $750 \pm 50$  rpm (A/T in "N" position) by turning idle adjusting screw?

No → Check for IACV-AAC valve clogging or throttle body clogging.

OR

1. Disconnect throttle position sensor harness connector.

2. Can you set engine speed at  $750 \pm 50$  rpm (A/T in "N" position) by turning idle adjusting screw?

Yes

(Go to **A** on next page.)

CF  
ME  
EV  
LC  
EC  
EE  
CL  
MT  
AT  
PD  
EA  
PA  
PR  
ST  
RS  
BT  
HA  
EL  
DX

## TROUBLE DIAGNOSES

### Diagnostic Procedure 14 — Symptom — Engine Stalls after Decelerating (Cont'd)

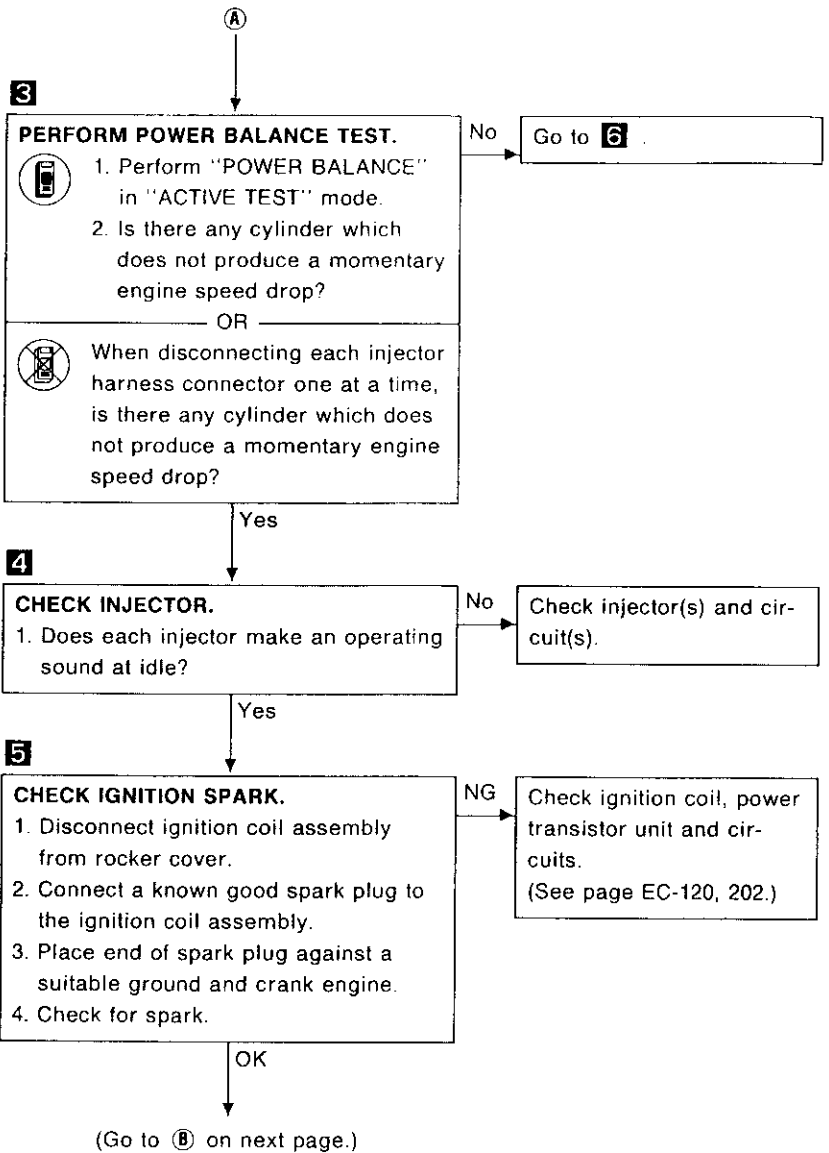
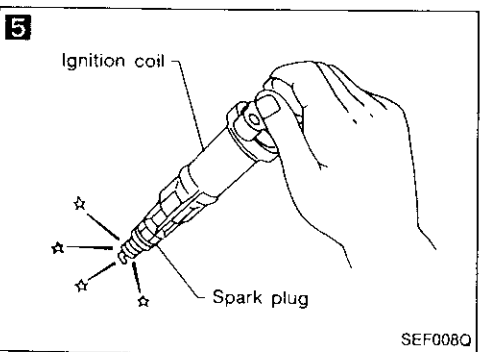
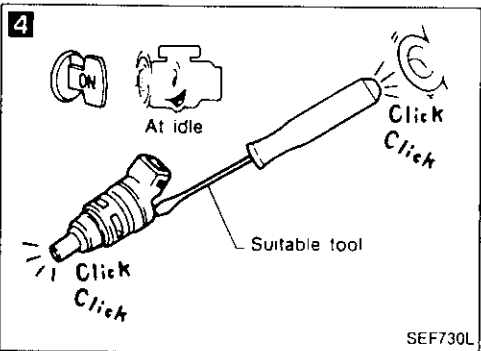
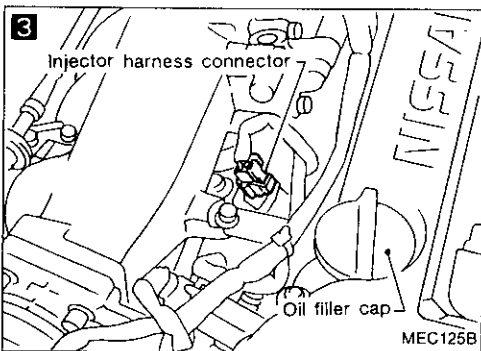
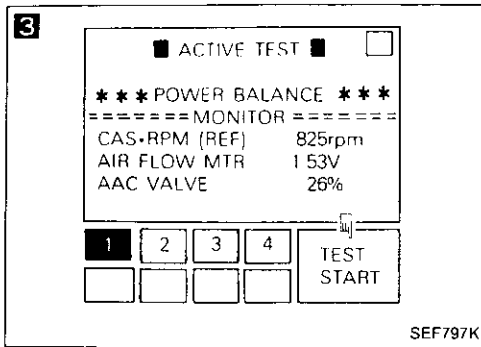



# TROUBLE DIAGNOSES

## Diagnostic Procedure 14 — Symptom — Engine Stalls after Decelerating (Cont'd)

**6** ■ FUEL PRES RELEASE ■

FUEL PUMP WILL STOP BY TOUCHING START DURING IDLE.  
CRANK A FEW TIMES AFTER ENGINE STALL

START



MEF688D

**6** **CHECK FUEL PRESSURE.**

1. Perform "FUEL PRESSURE RELEASE" in "WORK SUPPORT" mode in order to release fuel pressure to zero.

2. Install fuel pressure gauge and check fuel pressure.

**At idle approx. 245 kPa (2.45 bar, 2.5 kg/cm<sup>2</sup>, 36 psi)**

**The moment throttle valve is fully open: approx. 294 kPa (2.94 bar, 3.0 kg/cm<sup>2</sup>, 43 psi)**

OR

1. Release fuel pressure to zero. (Refer to page EC-208.)

2. Install fuel pressure gauge and check fuel pressure.

NG → Check fuel pressure regulator diaphragm.

**7** MIXTURE RATIO TEST

ACCELERATE TO 2000 RPM AND HOLD THEN TOUCH

**7** **CHECK HEATED OXYGEN SENSOR.**

1. Start engine and warm it up sufficiently.

NG → Replace heated oxygen sensor(s).

SI  
WA  
EM  
LG  
EC  
EE  
CL  
WT  
AT  
RE

## TROUBLE DIAGNOSES

### Diagnostic Procedure 14 — Symptom — Engine Stalls after Decelerating (Cont'd)

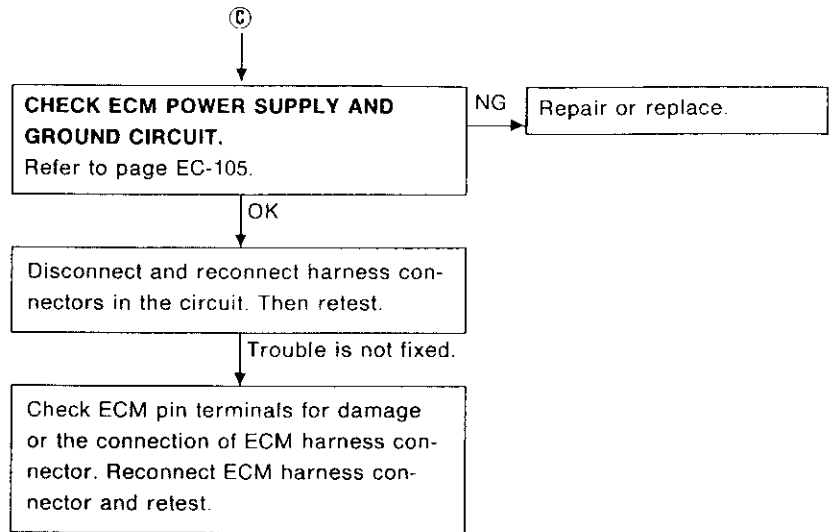

# TROUBLE DIAGNOSES

## Diagnostic Procedure 15 — Symptom — Engine Stalls when Accelerating or when Driving at Constant Speed

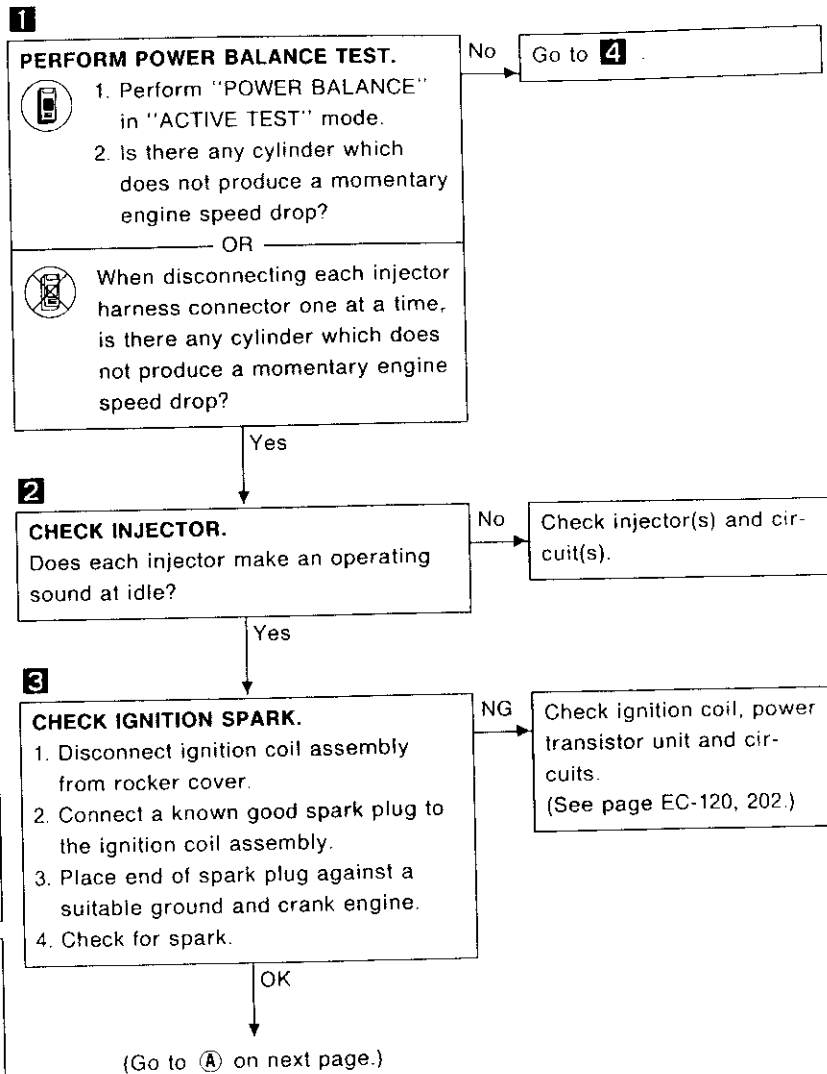
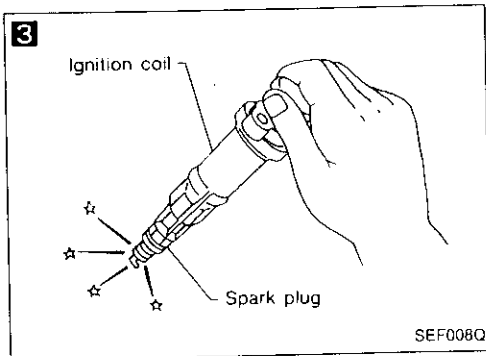
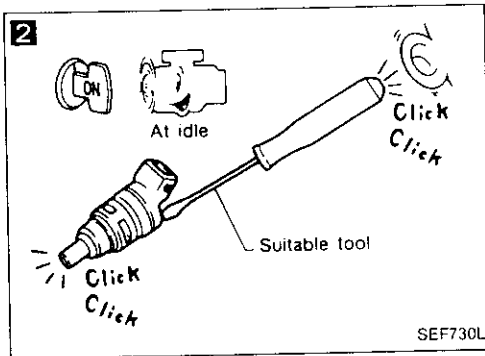
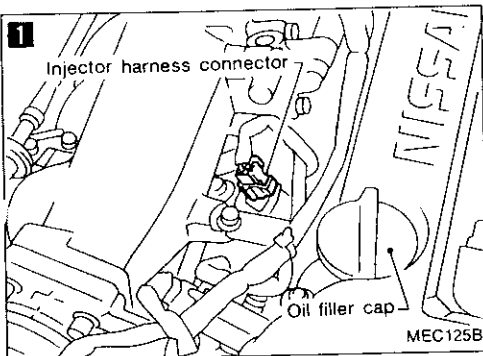
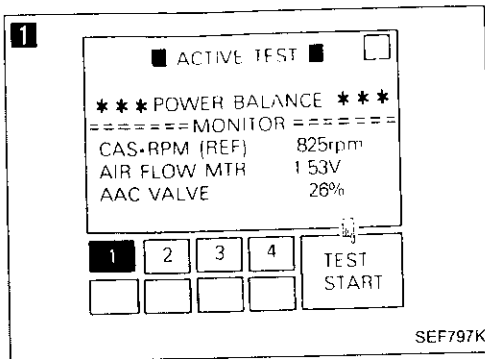

## TROUBLE DIAGNOSES

### Diagnostic Procedure 15 — Symptom — Engine Stalls when Accelerating or when Driving at Constant Speed (Cont'd)

**4** ■ FUEL PRES RELEASE ■

FUEL PUMP WILL STOP BY TOUCHING START DURING IDLE  
CRANK A FEW TIMES AFTER ENGINE STALL



START

↓

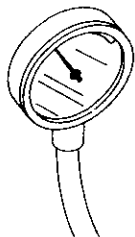

MEF707D

**5**

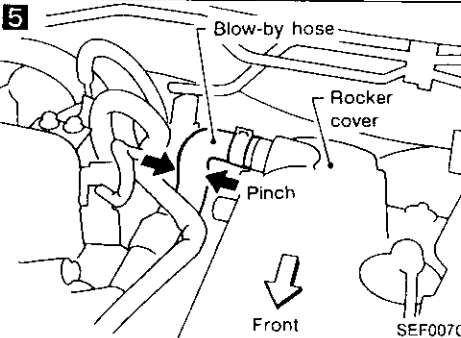

SEF007Q

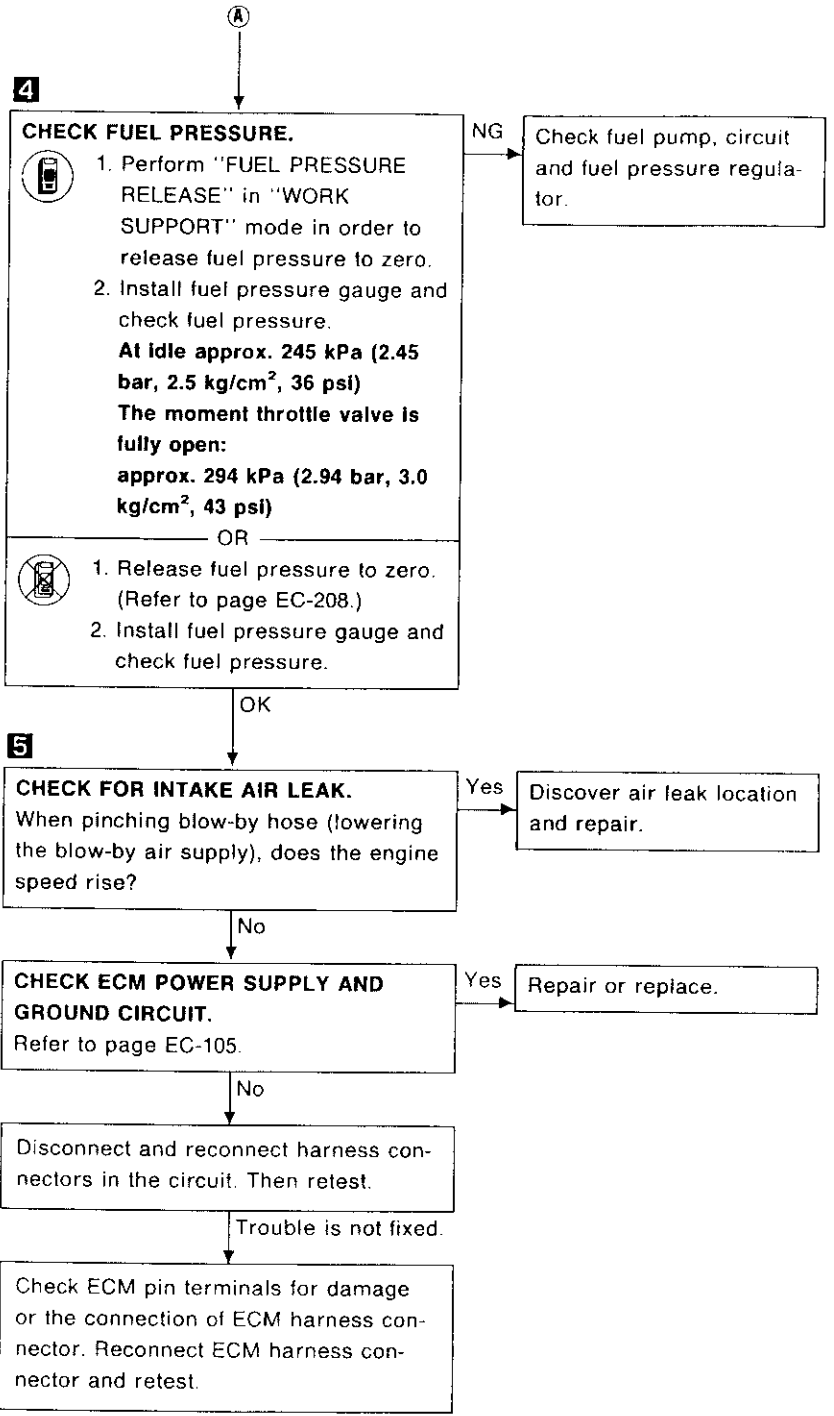

# TROUBLE DIAGNOSES

## Diagnostic Procedure 16 — Symptom — Engine Stalls when the Electrical Load is Heavy

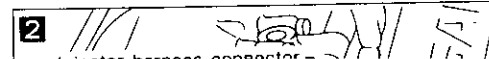
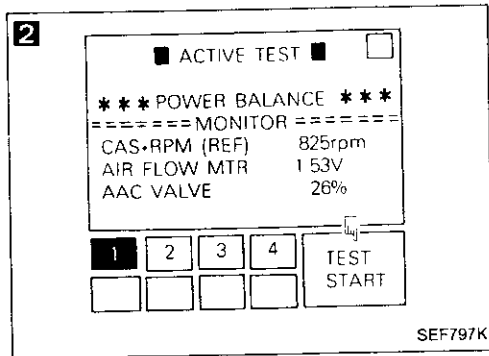
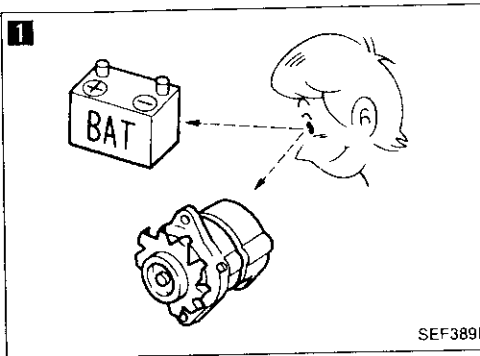

**1**  
**CHECK BATTERY AND ALTERNATOR.**  
 Check battery and alternator condition.  
 (Refer to EL section.)

NG → Repair or replace.

OK

**2**  
**PERFORM POWER BALANCE TEST.**

No → Go to **5**.

1. Perform "POWER BALANCE" in "ACTIVE TEST" mode.
2. Is there any cylinder which does not produce a momentary engine speed drop?

OR

- When disconnecting each injector harness connector one at a time, is there any cylinder which does not produce a momentary engine speed drop?

Yes

SI

MA

EM

LC

EC

FE

GL

MT

ST

## TROUBLE DIAGNOSES

### Diagnostic Procedure 16 — Symptom — Engine Stalls when the Electrical Load is Heavy (Cont'd)

**5**

■ FUEL PRES RELEASE ■

FUEL PUMP WILL STOP BY TOUCHING START DURING IDLE  
CRANK A FEW TIMES AFTER ENGINE STALL

START

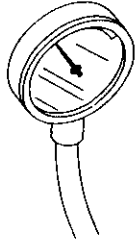

MEF699D

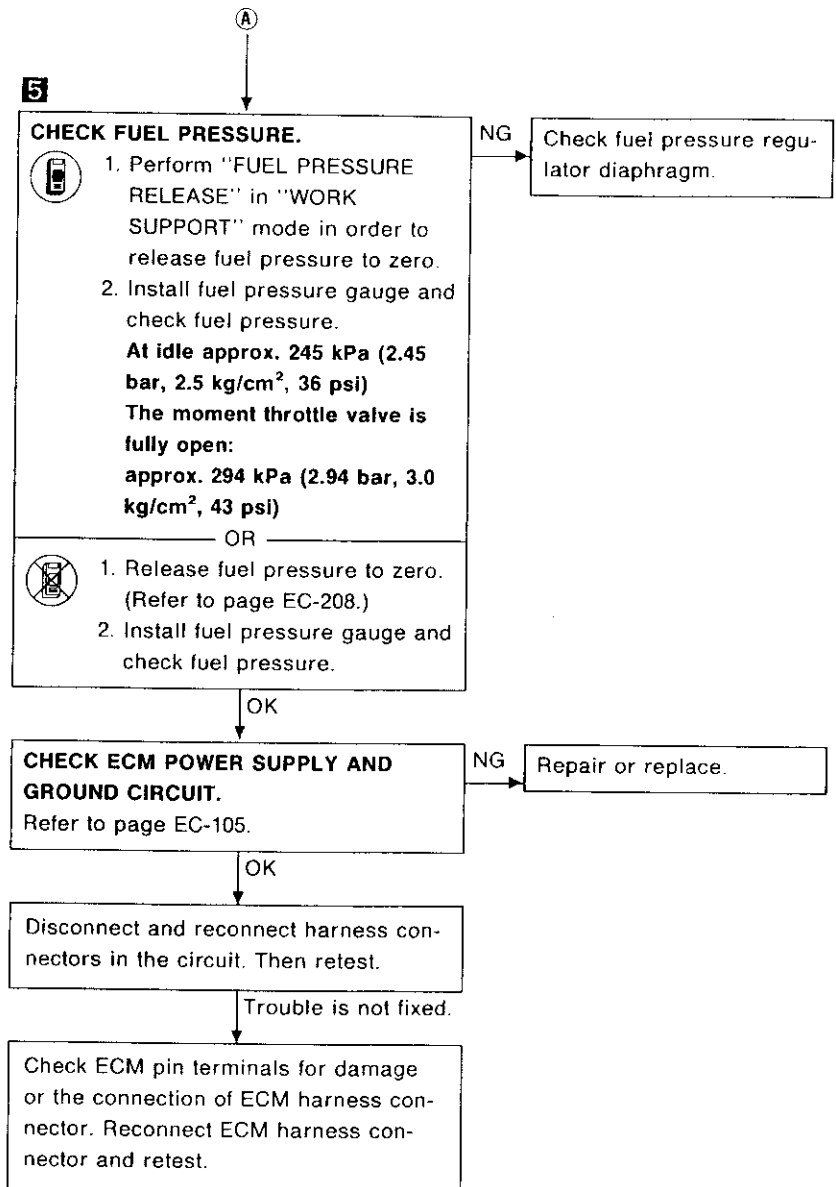

# TROUBLE DIAGNOSES

## Diagnostic Procedure 17 — Symptom — Lack of Power and Stumble

**1** ■ FUEL PRES RELEASE ■

FUEL PUMP WILL STOP BY TOUCHING START DURING IDLE  
CRANK A FEW TIMES AFTER ENGINE STALL

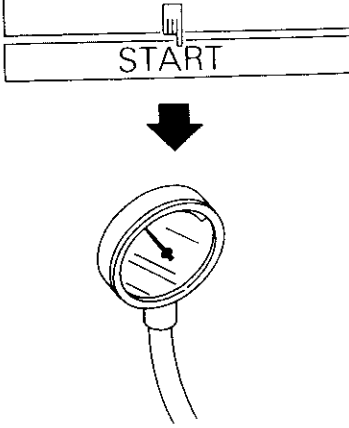

START

MEF708D

**2**

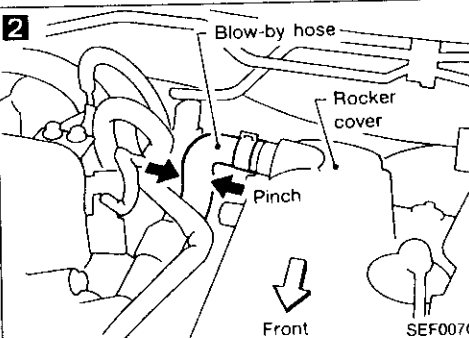

Blow-by hose

Rocker cover

Pinch

Front

SEF007Q

**1**

**CHECK FUEL PRESSURE.**

1. Perform "FUEL PRESSURE RELEASE" in "WORK SUPPORT" mode in order to release fuel pressure to zero.

2. Install fuel pressure gauge and check fuel pressure.

**At idle approx. 245 kPa (2.45 bar, 2.5 kg/cm<sup>2</sup>, 36 psi)**

**The moment throttle valve is fully open: approx. 294 kPa (2.94 bar, 3.0 kg/cm<sup>2</sup>, 43 psi)**

OR

1. Release fuel pressure to zero. (Refer to page EC-208.)

2. Install fuel pressure gauge and check fuel pressure.

NG → Check fuel pressure regulator diaphragm.

**2**

**CHECK FOR INTAKE AIR LEAK.**

When pinching blow-by hose (lowering the blow-by air supply), does the engine speed rise?

INSPECTION END

Yes → Discover air leak location and repair.

GI  
VA  
EM  
LC  
EC  
FE  
CL  
MT  
AT  
PD  
FA  
BA  
BR  
ST  
RS  
BT  
HA  
EL  
DX

Diagnostic Procedure

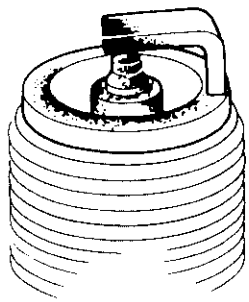

SEF156I

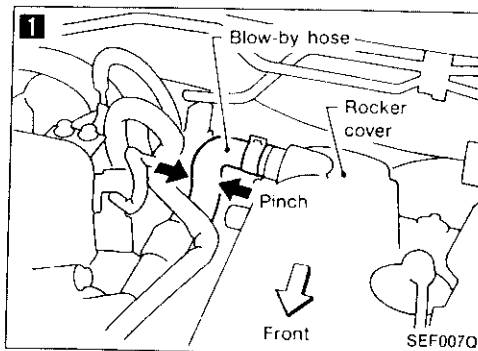

**1**  
**CHECK FOR INTAKE AIR LEAK.**  
When pinching blow-by hose (lower the blow-by air supply), does the engine speed rise?

**2**  
**CHECK EGR OPERATION.**  
1. Apply vacuum directly to the EGR valve using a handy vacuum pump.  
2. Check to see that the engine runs rough or dies.

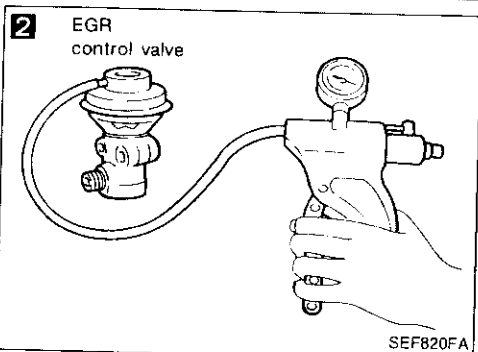

**3**  
**CHECK EGRC-SOLENOID VALVE.**  
1. Turn ignition switch "ON".  
2. Perform "EGR CONT S/V CIRCUIT" or "EGRC S/V CIRCUIT" in "FUNCTION TEST" mode.

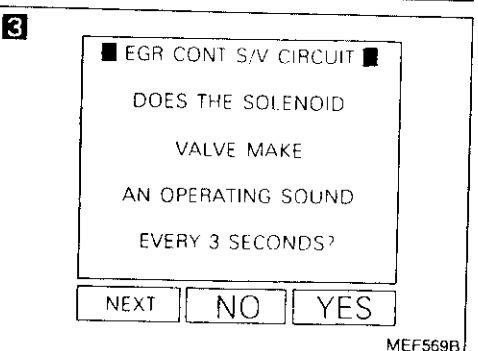

OR  
1. Turn ignition switch "ON".  
2. Select "EGR CONT SOL/V" or "EGRC SOL VALVE" in "ACTIVE TEST" mode.  
3. Turn EGRC-solenoid valve ON and OFF.  
4. Check operating sound.

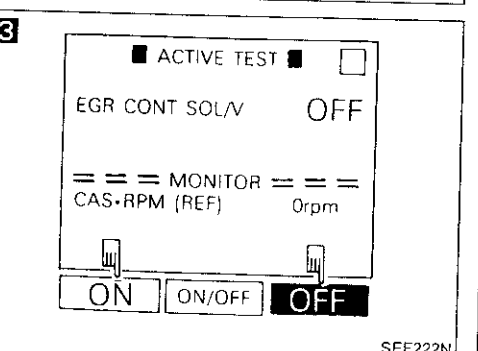

OR  
1. Disconnect EGRC-solenoid valve harness connector.  
2. Supply EGRC-solenoid valve terminals with battery current and check operating sound.

**4**  
**CHECK VACUUM HOSES.**  
Check the following vacuum hoses for clogging, cracks and poor connections:  
a) Vacuum hose between EGR valve

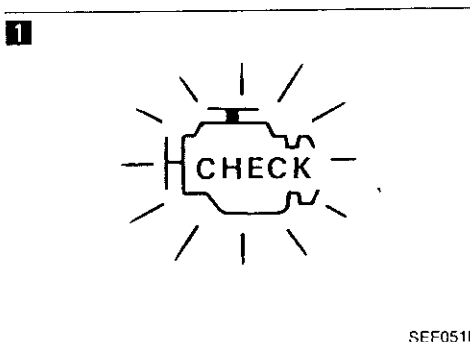
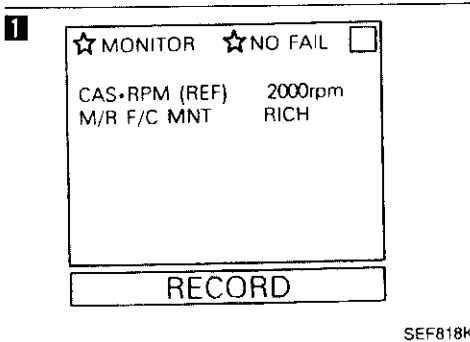
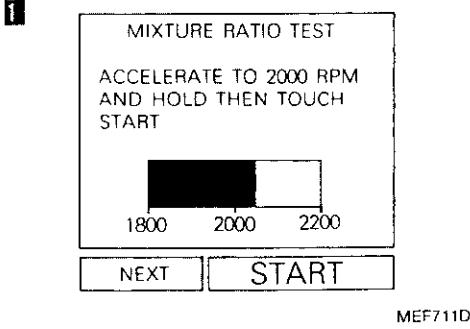

5  
CH  
TI  
Re  
ind

1  
C  
1

y  
n

3.



# TROUBLE DIAGNOSES

## Diagnostic Procedure 22

### MAIN POWER SUPPLY AND GROUND CIRCUIT (Not self-diagnostic item)

EC-MAIN-01

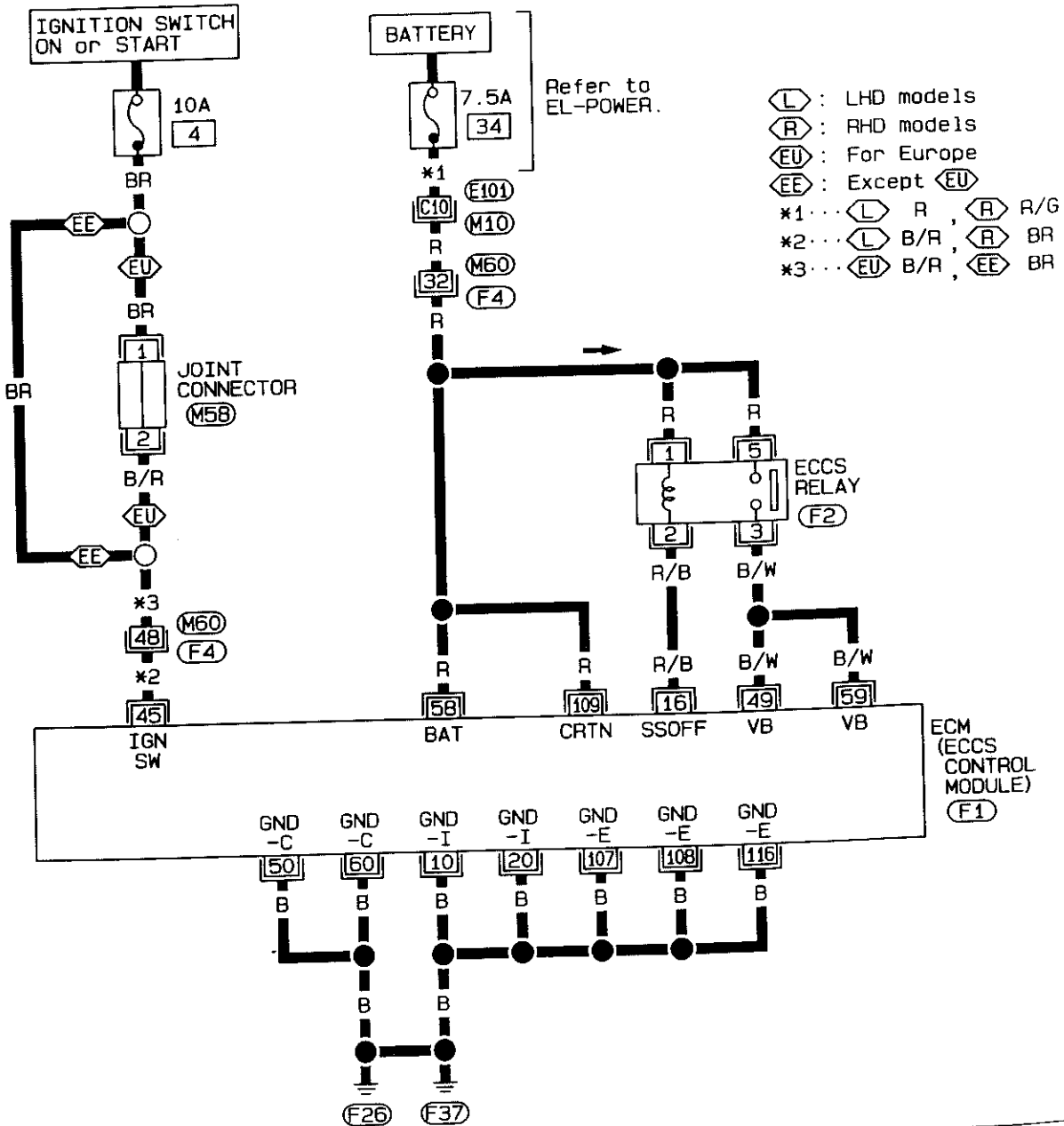

V  
 W  
 X  
 Y  
 Z  
 AA  
 AB  
 AC  
 AD  
 AE  
 AF  
 AG  
 AH  
 AI  
 AJ  
 AK  
 AL  
 AM  
 AN  
 AO  
 AP  
 AQ  
 AR  
 AS  
 AT  
 AU  
 AV  
 AW  
 AX  
 AY  
 AZ  
 BA  
 BB  
 BC  
 BD  
 BE  
 BF  
 BG  
 BH  
 BI  
 BJ  
 BK  
 BL  
 BM  
 BN  
 BO  
 BP  
 BQ  
 BR  
 BS  
 BT  
 BU  
 BV  
 BW  
 BX  
 BY  
 BZ  
 CA  
 CB  
 CC  
 CD  
 CE  
 CF  
 CG  
 CH  
 CI  
 CJ  
 CK  
 CL  
 CM  
 CN  
 CO  
 CP  
 CQ  
 CR  
 CS  
 CT  
 CU  
 CV  
 CW  
 CX  
 CY  
 CZ  
 DA  
 DB  
 DC  
 DD  
 DE  
 DF  
 DG  
 DH  
 DI  
 DJ  
 DK  
 DL  
 DM  
 DN  
 DO  
 DP  
 DQ  
 DR  
 DS  
 DT  
 DU  
 DV  
 DW  
 DX  
 DY  
 DZ  
 EA  
 EB  
 EC  
 ED  
 EE  
 EF  
 EG  
 EH  
 EI  
 EJ  
 EK  
 EL  
 EM  
 EN  
 EO  
 EP  
 EQ  
 ER  
 ES  
 ET  
 EU  
 EV  
 EW  
 EX  
 EY  
 EZ  
 FA  
 FB  
 FC  
 FD  
 FE  
 FF  
 FG  
 FH  
 FI  
 FJ  
 FK  
 FL  
 FM  
 FN  
 FO  
 FP  
 FQ  
 FR  
 FS  
 FT  
 FU  
 FV  
 FW  
 FX  
 FY  
 FZ  
 GA  
 GB  
 GC  
 GD  
 GE  
 GF  
 GG  
 GH  
 GI  
 GJ  
 GK  
 GL  
 GM  
 GN  
 GO  
 GP  
 GQ  
 GR  
 GS  
 GT  
 GU  
 GV  
 GW  
 GX  
 GY  
 GZ  
 HA  
 HB  
 HC  
 HD  
 HE  
 HF  
 HG  
 HH  
 HI  
 HJ  
 HK  
 HL  
 HM  
 HN  
 HO  
 HP  
 HQ  
 HR  
 HS  
 HT  
 HU  
 HV  
 HW  
 HX  
 HY  
 HZ  
 IA  
 IB  
 IC  
 ID  
 IE  
 IF  
 IG  
 IH  
 II  
 IJ  
 IK  
 IL  
 IM  
 IN  
 IO  
 IP  
 IQ  
 IR  
 IS  
 IT  
 IU  
 IV  
 IW  
 IX  
 IY  
 IZ  
 JA  
 JB  
 JC  
 JD  
 JE  
 JF  
 JG  
 JH  
 JI  
 JJ  
 JK  
 JL  
 JM  
 JN  
 JO  
 JP  
 JQ  
 JR  
 JS  
 JT  
 JU  
 JV  
 JW  
 JX  
 JY  
 JZ  
 KA  
 KB  
 KC  
 KD  
 KE  
 KF  
 KG  
 KH  
 KI  
 KJ  
 KK  
 KL  
 KM  
 KN  
 KO  
 KP  
 KQ  
 KR  
 KS  
 KT  
 KU  
 KV  
 KW  
 KX  
 KY  
 KZ  
 LA  
 LB  
 LC  
 LD  
 LE  
 LF  
 LG  
 LH  
 LI  
 LJ  
 LK  
 LL  
 LM  
 LN  
 LO  
 LP  
 LQ  
 LR  
 LS  
 LT  
 LU  
 LV  
 LW  
 LX  
 LY  
 LZ  
 MA  
 MB  
 MC  
 MD  
 ME  
 MF  
 MG  
 MH  
 MI  
 MJ  
 MK  
 ML  
 MN  
 MO  
 MP  
 MQ  
 MR  
 MS  
 MT  
 MU  
 MV  
 MW  
 MX  
 MY  
 MZ  
 NA  
 NB  
 NC  
 ND  
 NE  
 NF  
 NG  
 NH  
 NI  
 NJ  
 NK  
 NL  
 NM  
 NN  
 NO  
 NP  
 NQ  
 NR  
 NS  
 NT  
 NU  
 NV  
 NW  
 NX  
 NY  
 NZ  
 OA  
 OB  
 OC  
 OD  
 OE  
 OF  
 OG  
 OH  
 OI  
 OJ  
 OK  
 OL  
 OM  
 ON  
 OO  
 OP  
 OQ  
 OR  
 OS  
 OT  
 OU  
 OV  
 OW  
 OX  
 OY  
 OZ  
 PA  
 PB  
 PC  
 PD  
 PE  
 PF  
 PG  
 PH  
 PI  
 PJ  
 PK  
 PL  
 PM  
 PN  
 PO  
 PP  
 PQ  
 PR  
 PS  
 PT  
 PU  
 PV  
 PW  
 PX  
 PY  
 PZ  
 QA  
 QB  
 QC  
 QD  
 QE  
 QF  
 QG  
 QH  
 QI  
 QJ  
 QK  
 QL  
 QM  
 QN  
 QO  
 QP  
 QQ  
 QR  
 QS  
 QT  
 QU  
 QV  
 QW  
 QX  
 QY  
 QZ  
 RA  
 RB  
 RC  
 RD  
 RE  
 RF  
 RG  
 RH  
 RI  
 RJ  
 RK  
 RL  
 RM  
 RN  
 RO  
 RP  
 RQ  
 RR  
 RS  
 RT  
 RU  
 RV  
 RW  
 RX  
 RY  
 RZ  
 SA  
 SB  
 SC  
 SD  
 SE  
 SF  
 SG  
 SH  
 SI  
 SJ  
 SK  
 SL  
 SM  
 SN  
 SO  
 SP  
 SQ  
 SR  
 SS  
 ST  
 SU  
 SV  
 SW  
 SX  
 SY  
 SZ  
 TA  
 TB  
 TC  
 TD  
 TE  
 TF  
 TG  
 TH  
 TI  
 TJ  
 TK  
 TL  
 TM  
 TN  
 TO  
 TP  
 TQ  
 TR  
 TS  
 TT  
 TU  
 TV  
 TW  
 TX  
 TY  
 TZ  
 UA  
 UB  
 UC  
 UD  
 UE  
 UF  
 UG  
 UH  
 UI  
 UJ  
 UK  
 UL  
 UM  
 UN  
 UO  
 UP  
 UQ  
 UR  
 US  
 UT  
 UU  
 UV  
 UW  
 UX  
 UY  
 UZ  
 VA  
 VB  
 VC  
 VD  
 VE  
 VF  
 VG  
 VH  
 VI  
 VJ  
 VK  
 VL  
 VM  
 VN  
 VO  
 VP  
 VQ  
 VR  
 VS  
 VT  
 VU  
 VV  
 VW  
 VX  
 VY  
 VZ  
 WA  
 WB  
 WC  
 WD  
 WE  
 WF  
 WG  
 WH  
 WI  
 WJ  
 WK  
 WL  
 WM  
 WN  
 WO  
 WP  
 WQ  
 WR  
 WS  
 WT  
 WU  
 WV  
 WW  
 WX  
 WY  
 WZ  
 XA  
 XB  
 XC  
 XD  
 XE  
 XF  
 XG  
 XH  
 XI  
 XJ  
 XK  
 XL  
 XM  
 XN  
 XO  
 XP  
 XQ  
 XR  
 XS  
 XT  
 XU  
 XV  
 XW  
 XX  
 XY  
 XZ  
 YA  
 YB  
 YC  
 YD  
 YE  
 YF  
 YG  
 YH  
 YI  
 YJ  
 YK  
 YL  
 YM  
 YN  
 YO  
 YP  
 YQ  
 YR  
 YS  
 YT  
 YU  
 YV  
 YW  
 YX  
 YZ  
 ZA  
 ZB  
 ZC  
 ZD  
 ZE  
 ZF  
 ZG  
 ZH  
 ZI  
 ZJ  
 ZK  
 ZL  
 ZM  
 ZN  
 ZO  
 ZP  
 ZQ  
 ZR  
 ZS  
 ZT  
 ZU  
 ZV  
 ZW  
 ZX  
 ZY  
 ZZ

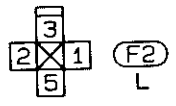
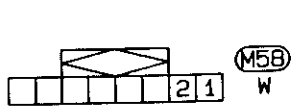

Refer to last page (Foldout page).

(M10), (E101)  
(M60), (F4)

(F1)  
L



SEF824P

101	102	103	104	105	106	107	108	1	2	3	4	5	6	7	8	9	10	21	22	23	24	25	26	27	28	29	30	41	42	43	44	45	46	47	48	49	50
109	110	111	112	113	114	115	116	11	12	13	14	15	16	17	18	19	20	31	32	33	34	35	36	37	38	39	40	51	52	53	54	55	56	57	58	59	60

# TROUBLE DIAGNOSES

## Diagnostic Procedure 22 (Cont'd)

### Harness layout

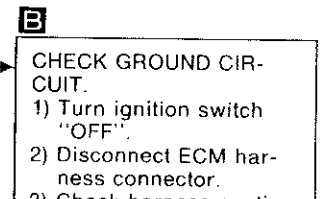
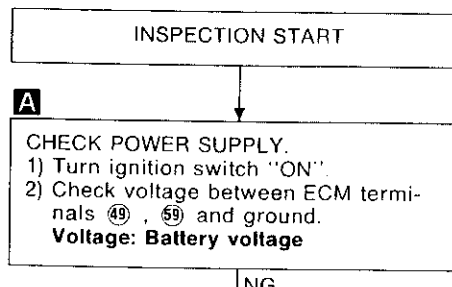
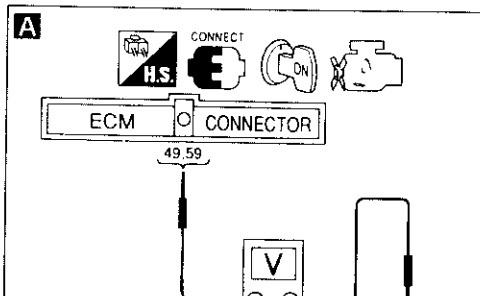
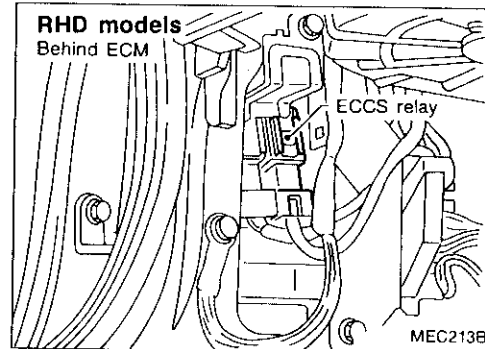
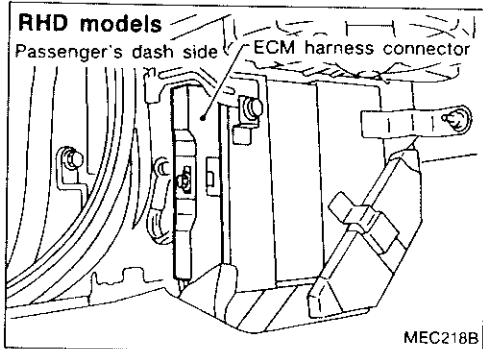
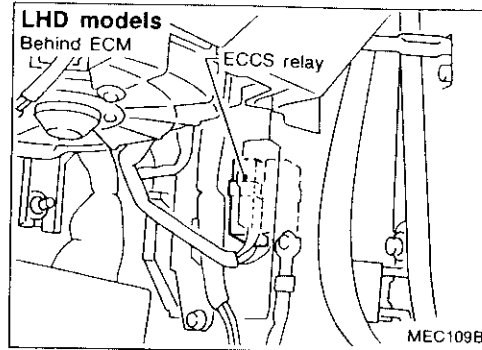
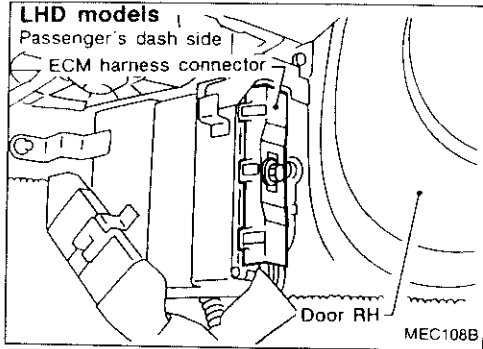

OK

NG

# TROUBLE DIAGNOSES

## Diagnostic Procedure 22 (Cont'd)

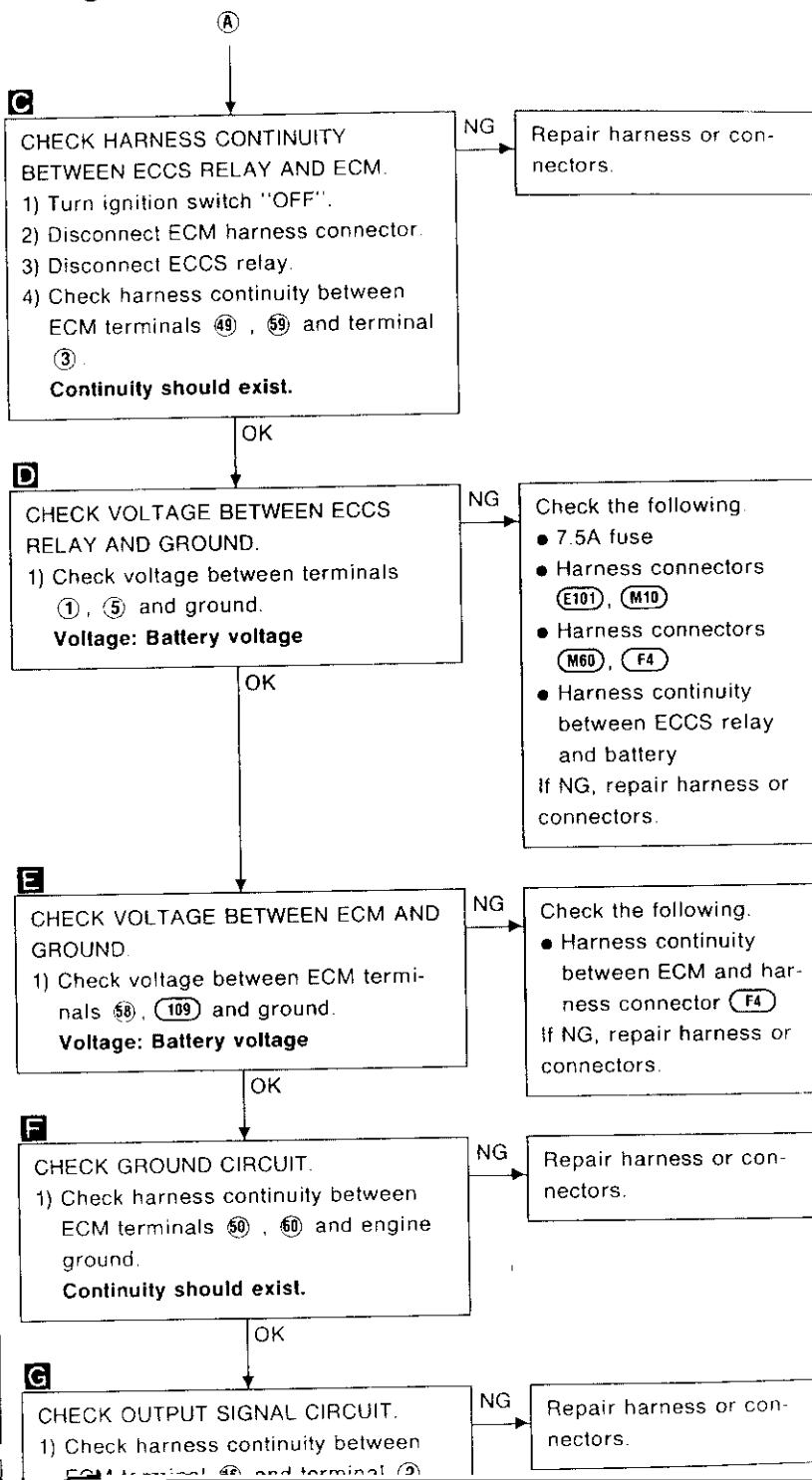
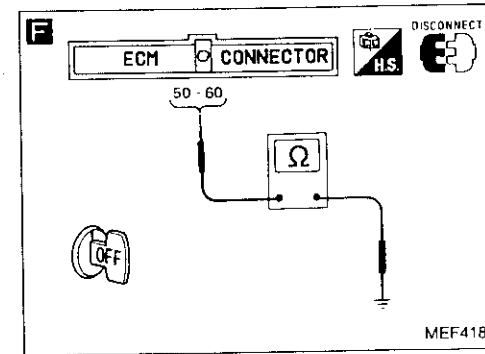
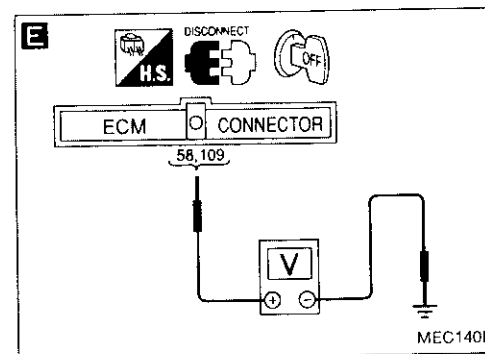
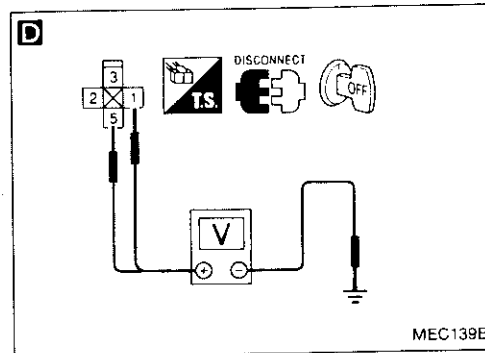
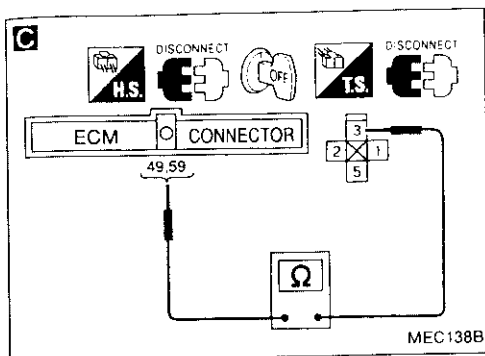

## TROUBLE DIAGNOSES

### Diagnostic Procedure 22 (Cont'd)

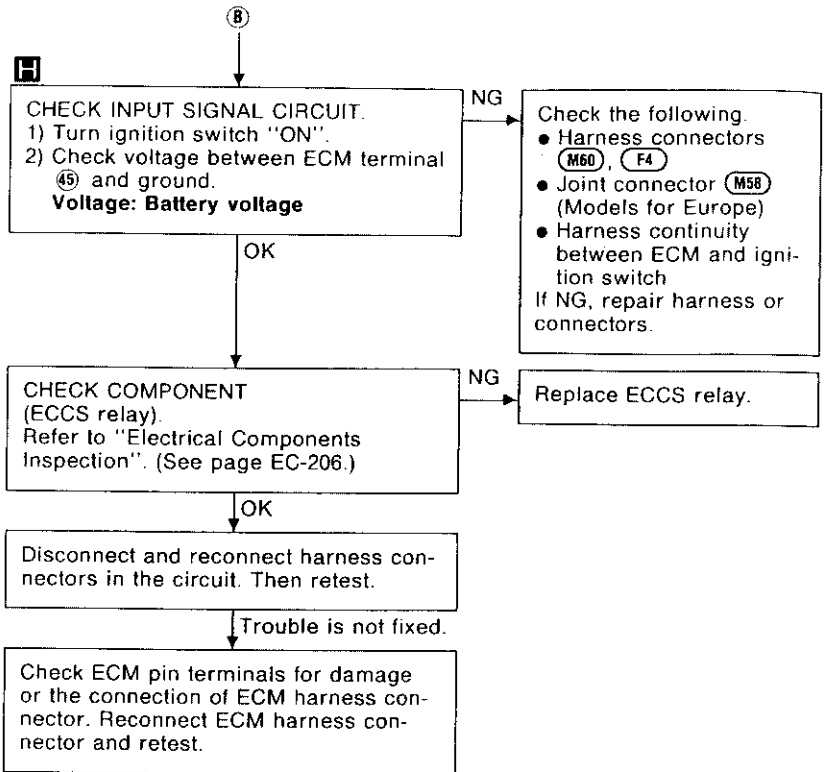
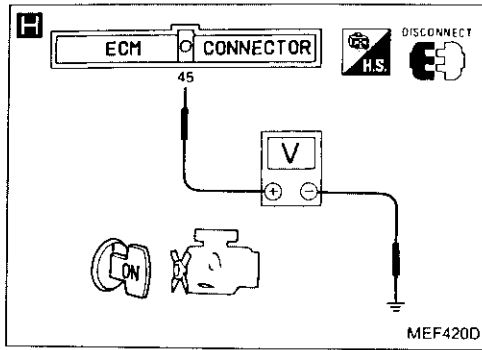

# TROUBLE DIAGNOSES

## Diagnostic Procedure 23

### CAMSHAFT POSITION SENSOR (Diagnostic trouble code No. 11)

LHD MODELS

EC-CMPS-01

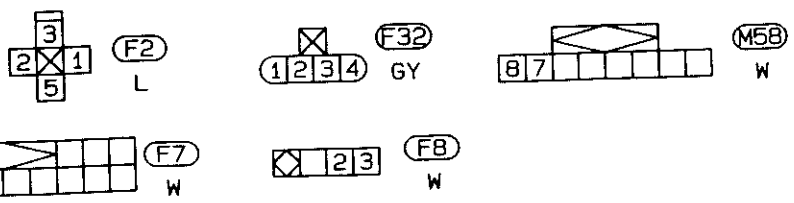
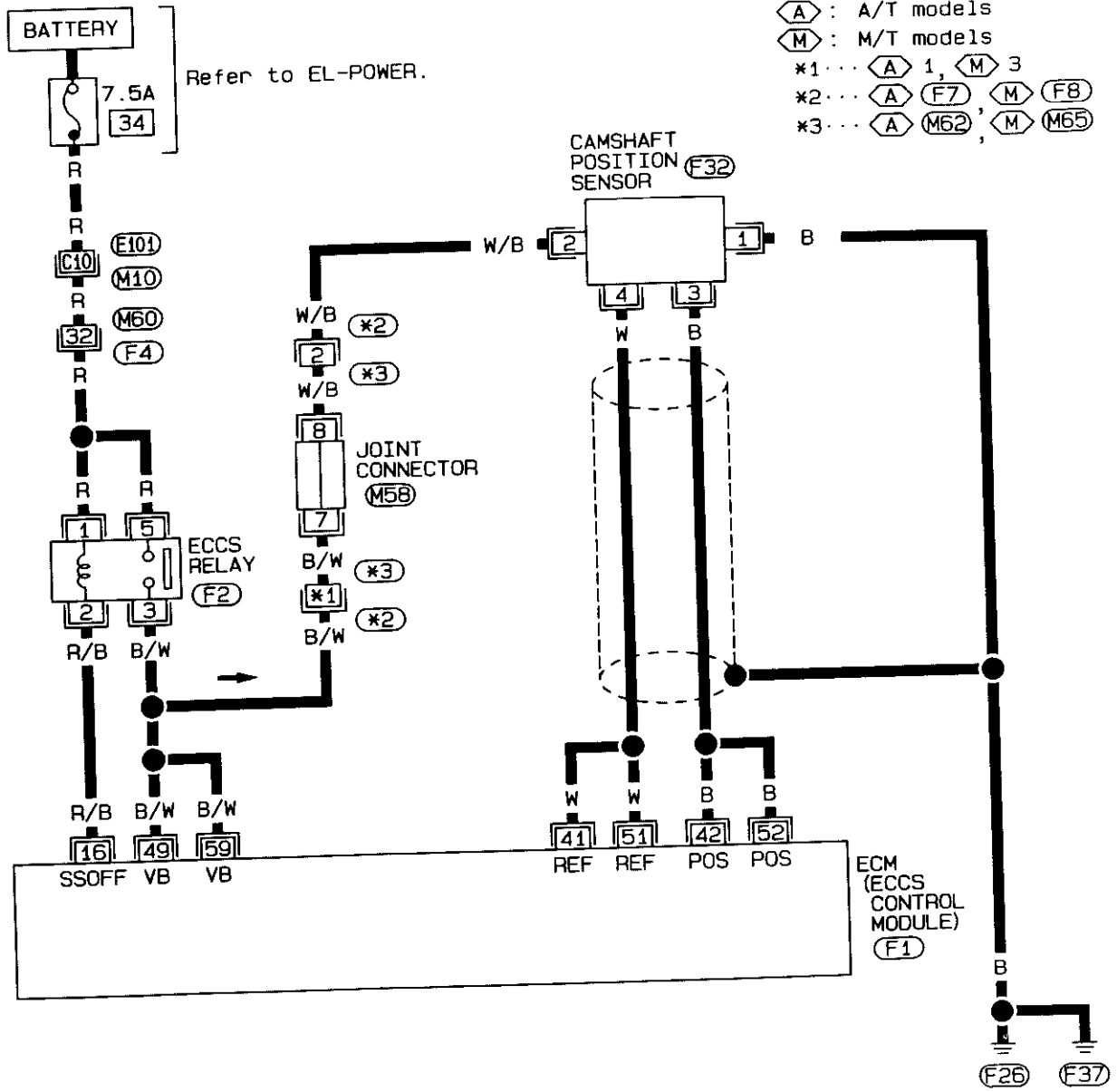

Refer to last page (Foldout page).

- (M10) (E101)
- (M60) (F4)

101	102	103	104	105	106	107	108	1	2	3	4	5	6	7	8	9	10	21	22	23	24	25	26	27	28	29	30	41	42	43	44	45	46	47	48	49	50
109	110	111	112	113	114	115	116	11	12	13	14	15	16	17	18	19	20	31	32	33	34	35	36	37	38	39	40	51	52	53	54	55	56	57	58	59	60

(F1)  
L



# TROUBLE DIAGNOSES

## Diagnostic Procedure 23 (Cont'd)

RHD MODELS

EC-CMPS-02

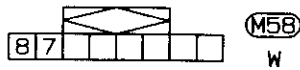
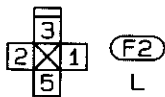
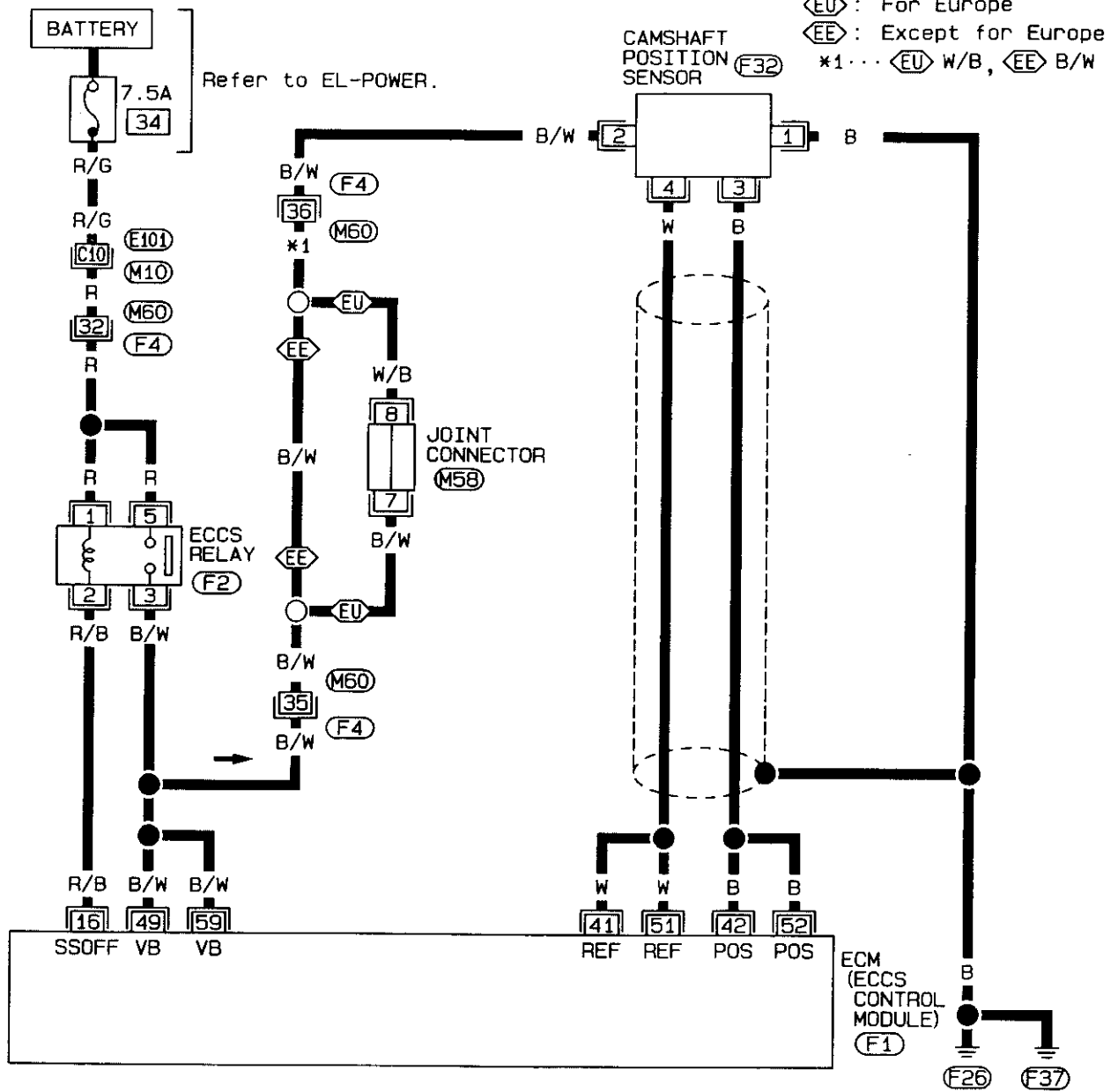

Refer to last page (Foldout page).

(M10), (E101)  
(M60), (F4)

101	102	103	104	105	106	107	108	1	2	3	4	5	6	7	8	9	10	21	22	23	24	25	26	27	28	29	30	41	42	43	44	45	46	47	48	49	50
109	110	111	112	113	114	115	116	11	12	13	14	15	16	17	18	19	20	31	32	33	34	35	36	37	38	39	40	51	52	53	54	55	56	57	58	59	60

(F1) L



# TROUBLE DIAGNOSES

## Diagnostic Procedure 23 (Cont'd)

### Harness layout

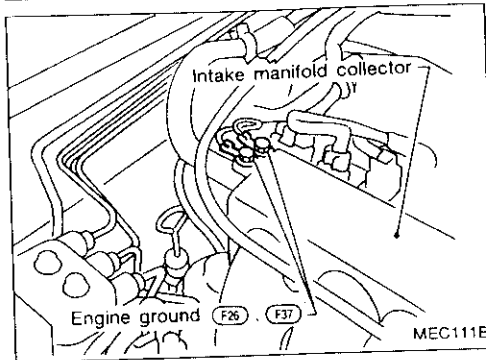
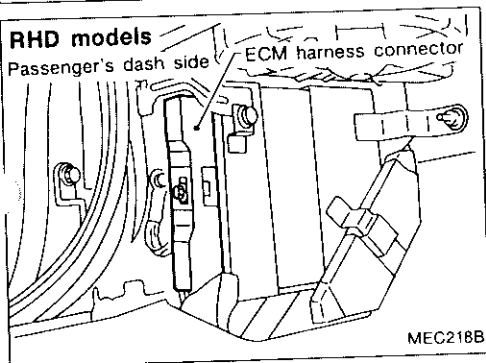
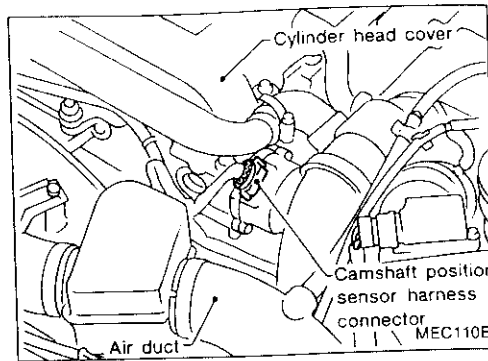
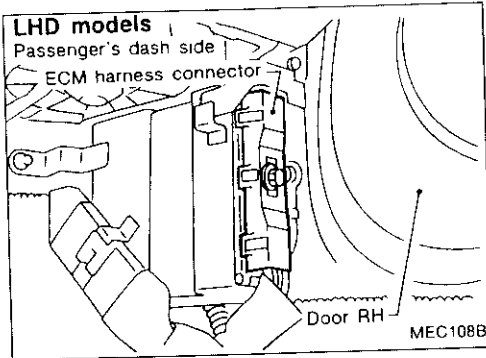

INSPECTION START

**A**  
CHECK POWER SUPPLY.  
1) Disconnect camshaft position sensor harness connector.  
2) Turn ignition switch "ON".  
3) Check voltage between terminal (b) and ground.  
**Voltage: Battery voltage**

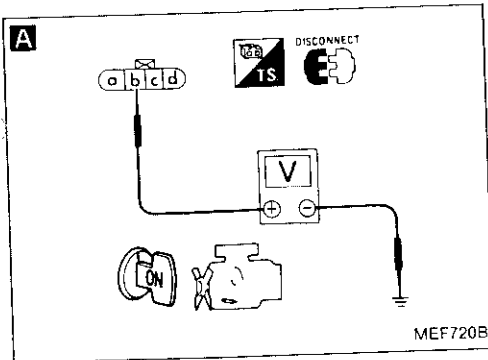

NG → Check the following.

- Harness connectors (F7, M62) (LHD A/T models)
- Harness connectors (F8, M65) (LHD M/T models)
- Harness connectors (M60, F4) (RHD models)
- Joint connector (M56) (Models for Europe)
- Harness continuity between camshaft position sensor and ECCS relay

If NG, repair harness or connectors.

**B**  
CHECK GROUND CIRCUIT.  
1) Turn ignition switch "OFF".  
2) Loosen and retighten ground screws.  
3) Check harness continuity between terminal (a) and engine ground.  
**Continuity should exist.**

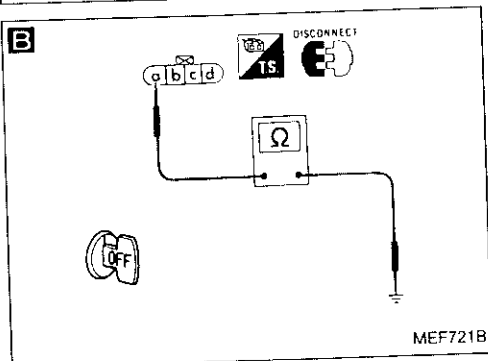

NG → Repair harness or connectors.

OK  
A

# TROUBLE DIAGNOSES

## Diagnostic Procedure 23 (Cont'd)

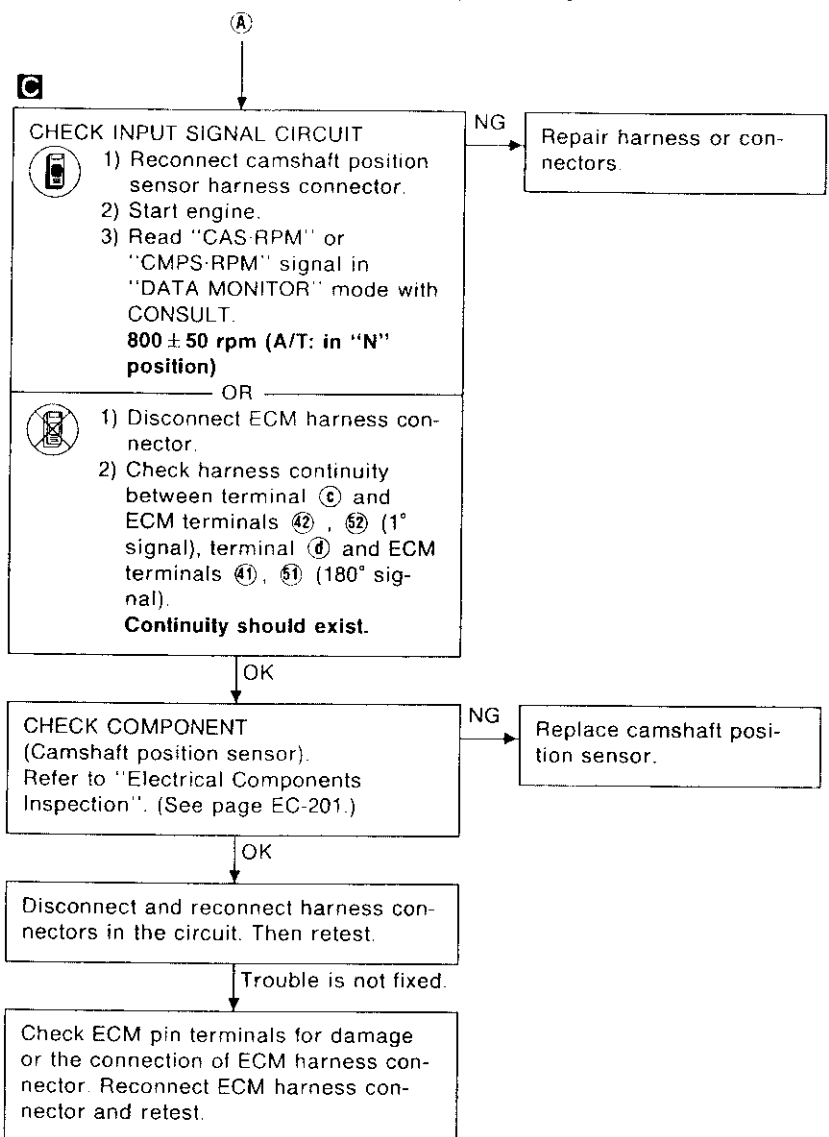
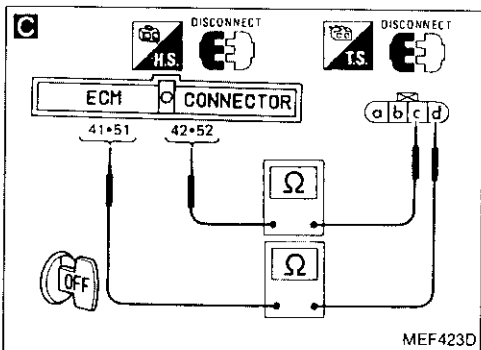
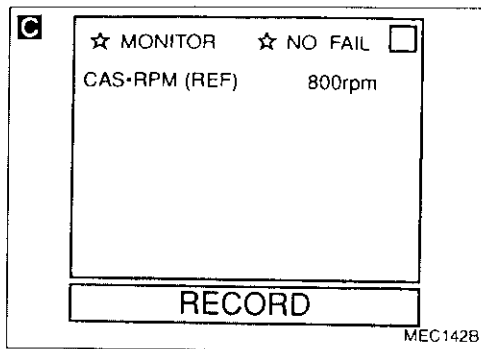

**Perform FINAL CHECK by the following procedure after repair is completed.**

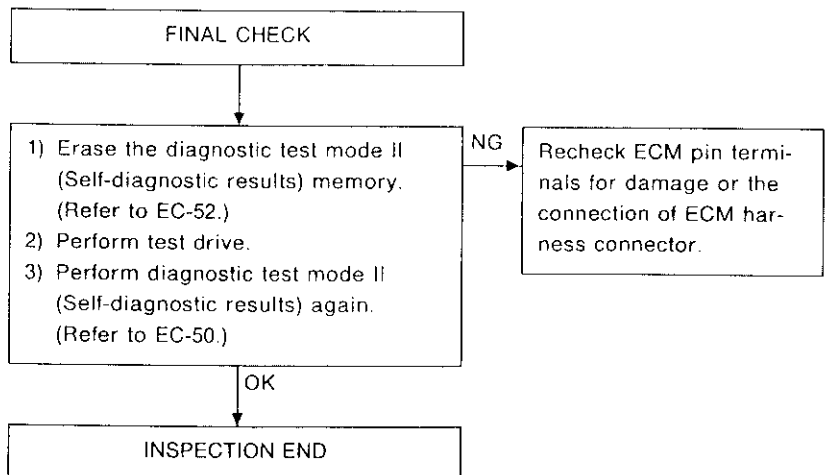



# TROUBLE DIAGNOSES

## Diagnostic Procedure 24

MASS AIR FLOW SENSOR (Diagnostic trouble code No. 12)

EC-MAFS-01

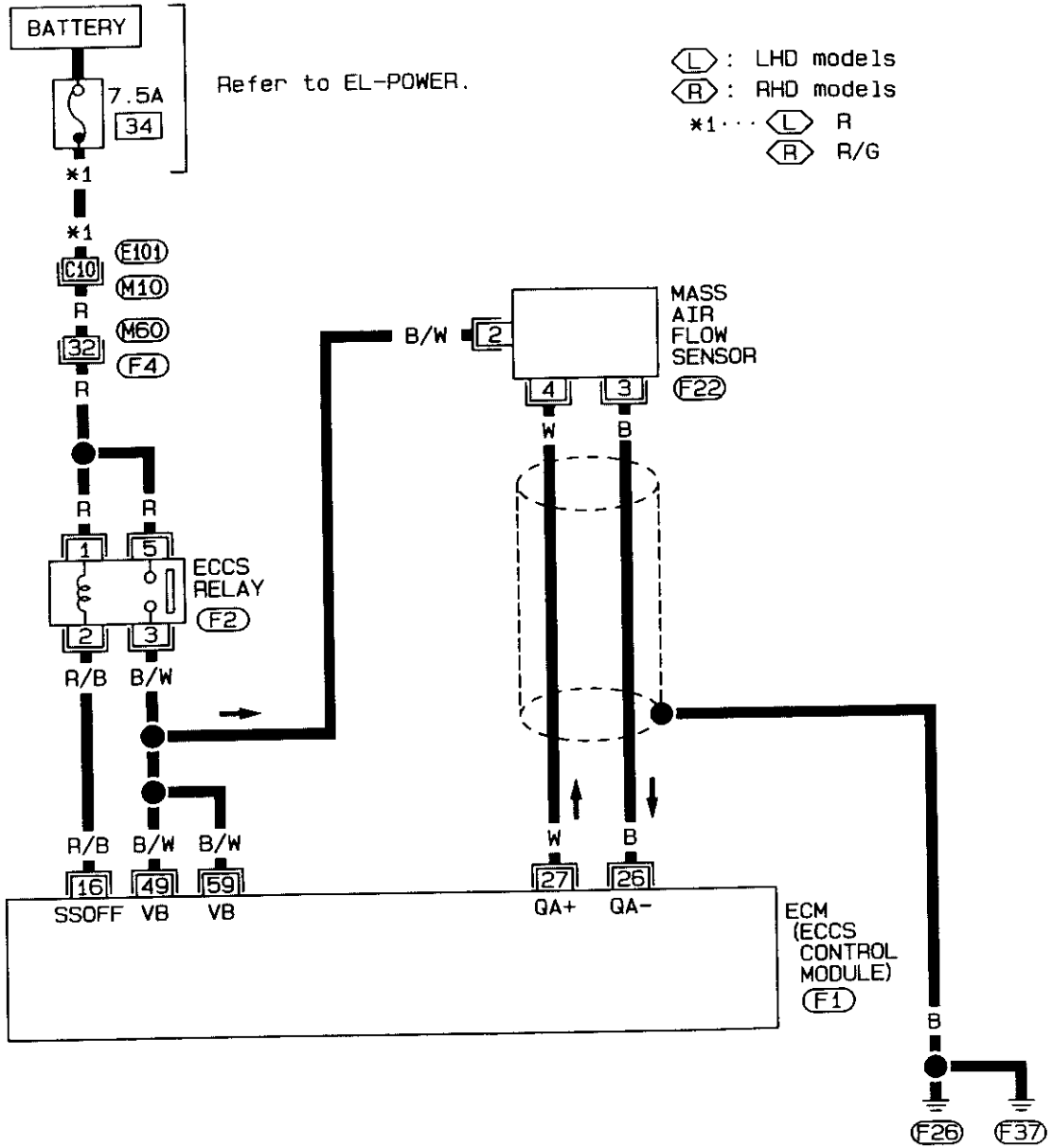

Refer to last page (Foldout page).

(M10) (E101)  
 (M60) (F4)

101	102	103	104	105	106	107	108	1	2	3	4	5	6	7	8	9	10	21	22	23	24	25	26	27	28	29	30	41	42	43	44	45	46	47	48	49	50
109	110	111	112	113	114	115	116	11	12	13	14	15	16	17	18	19	20	31	32	33	34	35	36	37	38	39	40	51	52	53	54	55	56	57	58	59	60

(F1) L



SEF826P

# TROUBLE DIAGNOSES

## Diagnostic Procedure 24 (Cont'd)

### Harness layout

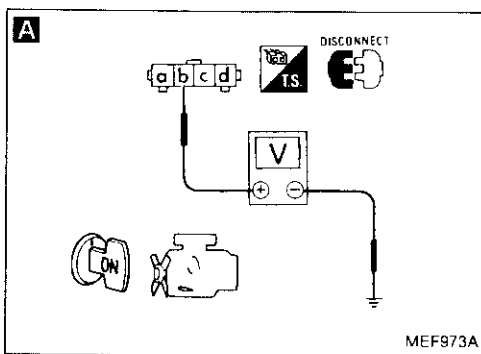
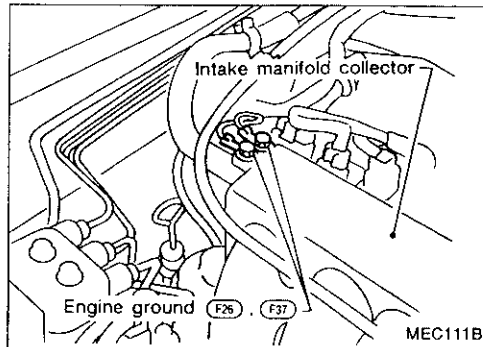
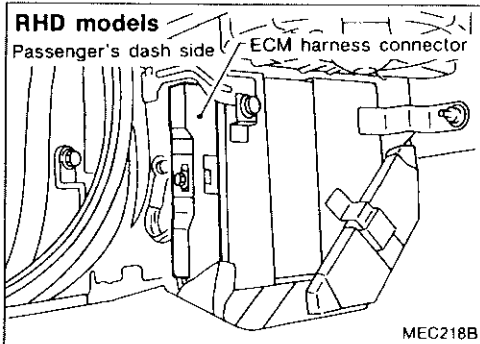
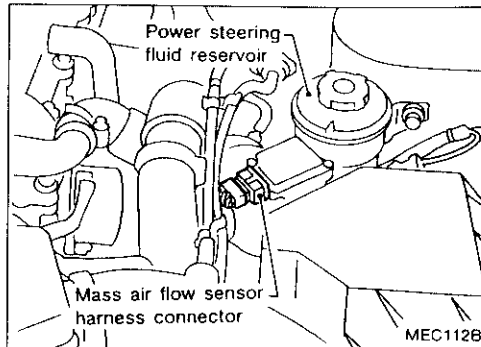
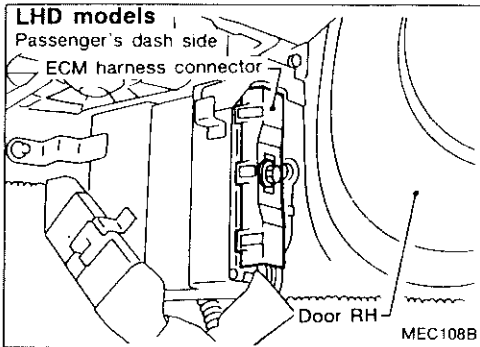

INSPECTION START

**A**  
**CHECK POWER SUPPLY.**  
1) Disconnect mass air flow sensor harness connector.  
2) Turn ignition switch "ON".  
3) Check voltage between terminal (b) and ground.  
**Voltage: Battery voltage**

NG → Check the following.  
● Harness continuity between mass air flow sensor and ECCS relay  
If NG, repair harness or connectors.

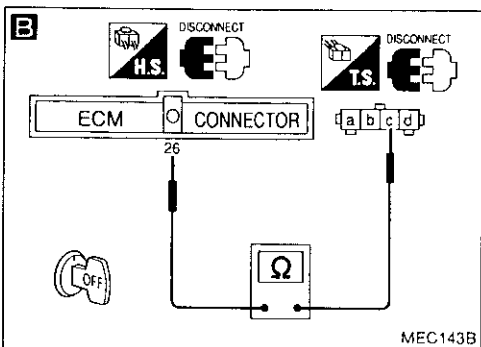

**B**  
**CHECK GROUND CIRCUIT.**  
1) Turn ignition switch "OFF".  
2) Disconnect ECM harness connector.  
3) Loosen and retighten ground screws.  
4) Check harness continuity between terminal (c) and ECM terminal (26).  
**Continuity should exist.**

NG → Repair harness or connectors.

OK  
↓  
**A**

# TROUBLE DIAGNOSES

## Diagnostic Procedure 24 (Cont'd)

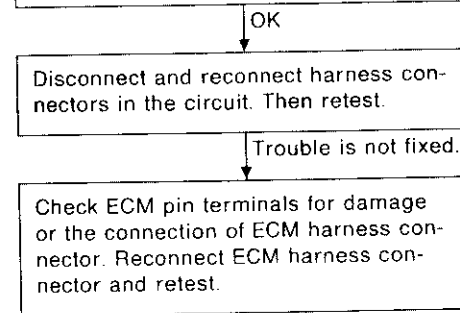
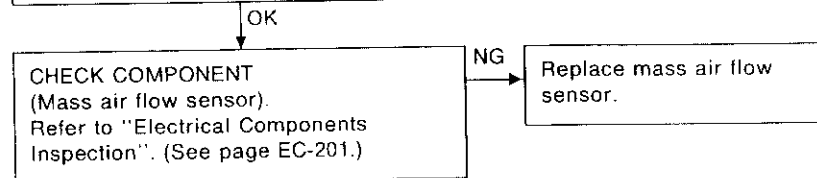
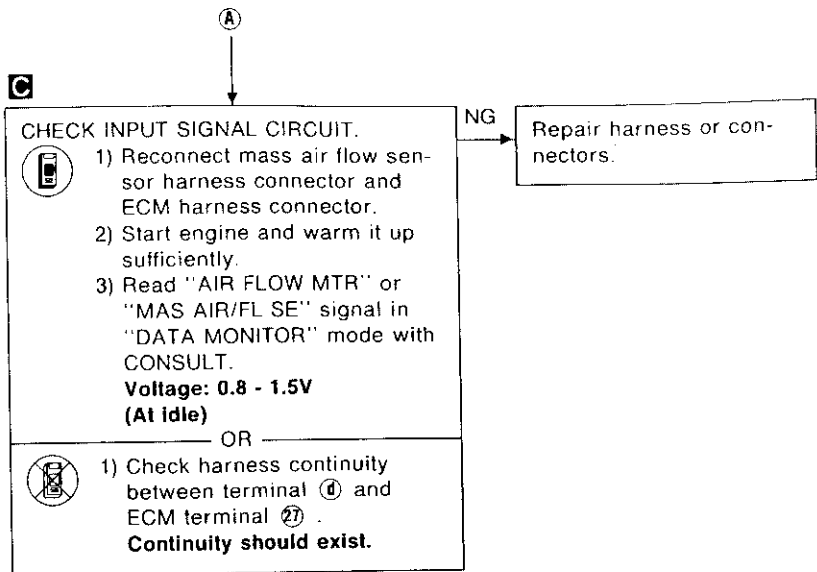
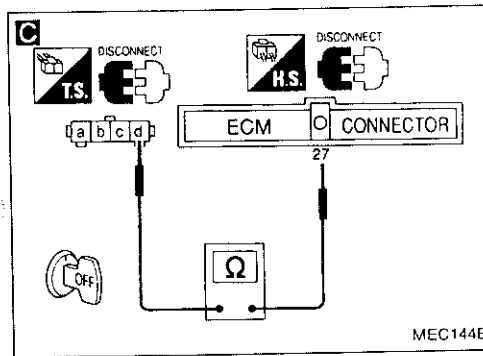
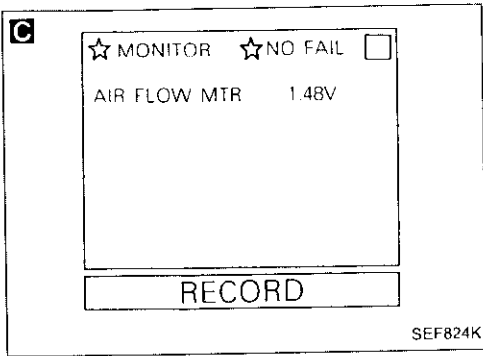

**Perform FINAL CHECK by the following procedure after repair is completed.**

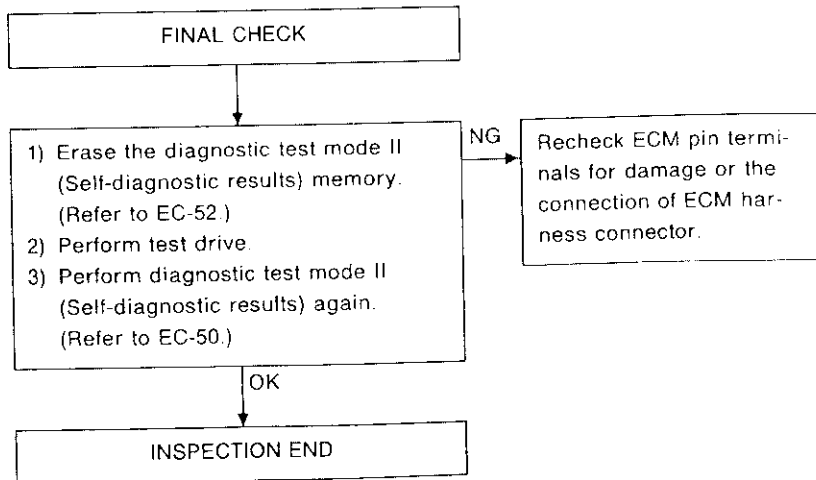

# TROUBLE DIAGNOSES

## Diagnostic Procedure 25

### ENGINE COOLANT TEMPERATURE SENSOR (Diagnostic trouble code No. 13)

EC-ECTS-01

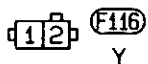
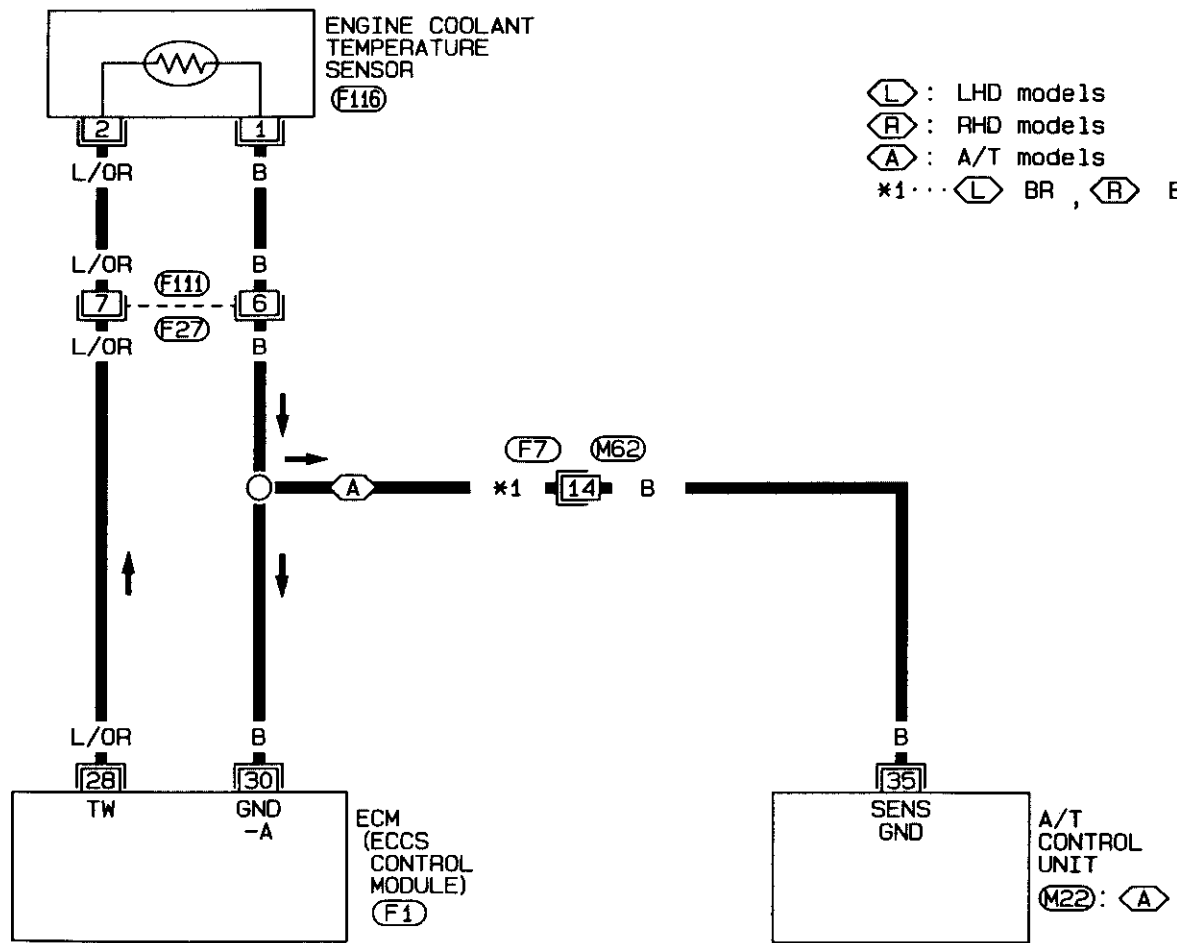

M22  
L

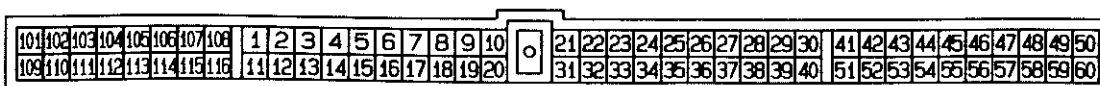

(F1)  
L



SEF827P

# TROUBLE DIAGNOSES

## Diagnostic Procedure 25 (Cont'd)

### Harness layout

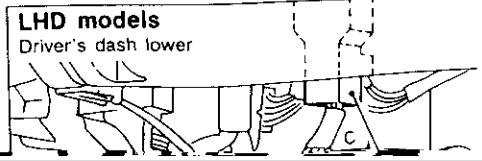
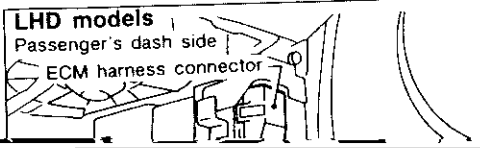

GI

MA

# TROUBLE DIAGNOSES

## Diagnostic Procedure 25 (Cont'd)

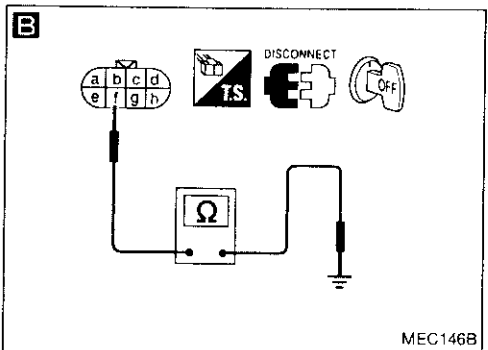
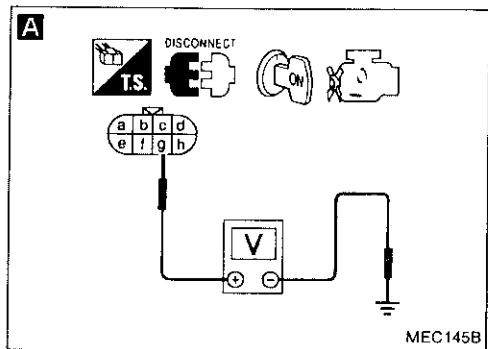
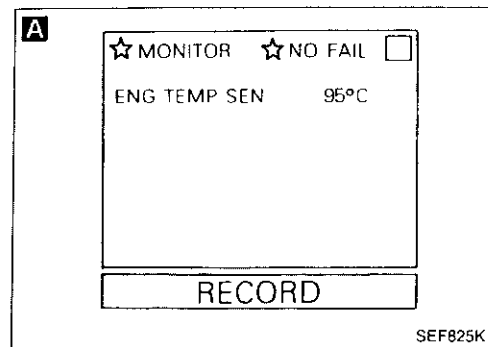

INSPECTION START

**A**

**CHECK POWER SUPPLY.**

- 1) Start engine and warm it up sufficiently.
- 2) Select "ENG TEMP SEN" or "COOLAN TEMP/S" signal in "DATA MONITOR" mode with CONSULT.
- 3) Stop engine.
- 4) When restarting engine make sure that CONSULT indicates "ENG TEMP SEN" or "COOLAN TEMP/S" is 50°C (122°F) or more.

OR

- 1) Disconnect harness connectors (F27, F111).
- 2) Turn ignition switch "ON".
- 3) Check voltage between terminal (g) and ground.

**Voltage: Approximately 5V**

NG

Check the following.

- Harness continuity between ECM and harness control (F27)

If NG, repair harness or connectors.

**B**

**CHECK GROUND CIRCUIT.**

- 1) Turn ignition switch "OFF".
- 2) Check harness continuity between terminal (f) and engine ground.

**Continuity should exist.**

NG

Check the following.

- Harness connectors (F7, M62) (A/T models)
- Harness continuity between ECM and harness connector (F27)
- Harness continuity between A/T control unit and harness connector (F27)

If NG, repair harness or connectors.

**CHECK COMPONENT**  
(Engine coolant temperature sensor). Refer to "Electrical Components Inspection". (See page EC-201.)

NG

Replace engine coolant temperature sensor.

Disconnect and reconnect harness connectors in the circuit. Then retest.

Trouble is not fixed.

Check ECM pin terminals for damage or the connection of ECM harness connector. Reconnect ECM harness connector and retest.

## TROUBLE DIAGNOSES

### Diagnostic Procedure 25 (Cont'd)

Perform FINAL CHECK by the following procedure after repair is completed.

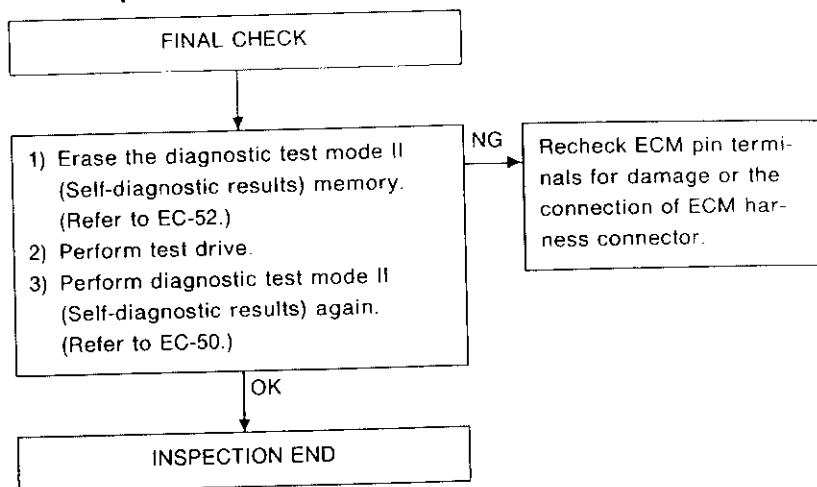

# TROUBLE DIAGNOSES

## Diagnostic Procedure 26

IGNITION SIGNAL (Diagnostic trouble code No. 21)

LHD MODELS

EC-IGN/SG-01

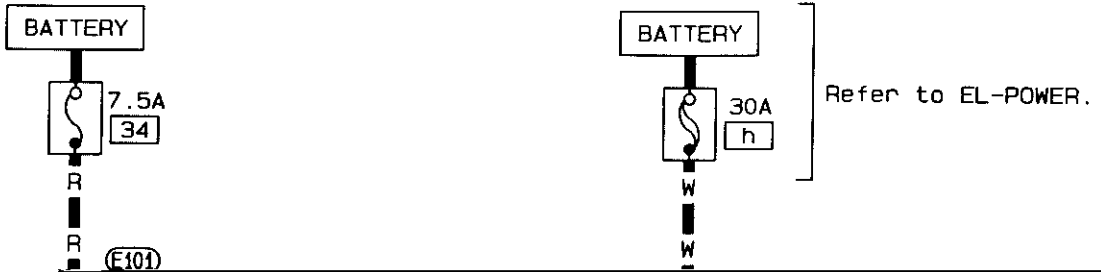



# TROUBLE DIAGNOSES

## Diagnostic Procedure 26 (Cont'd)

### EC-IGN/SG-02

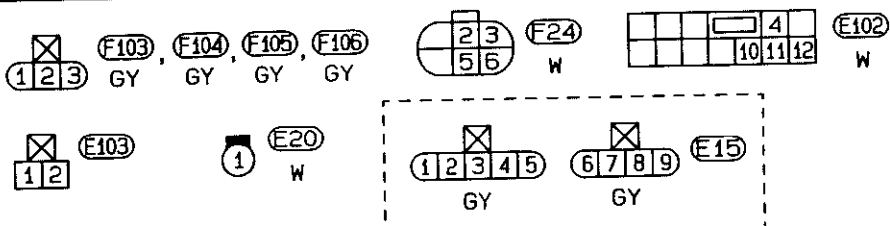
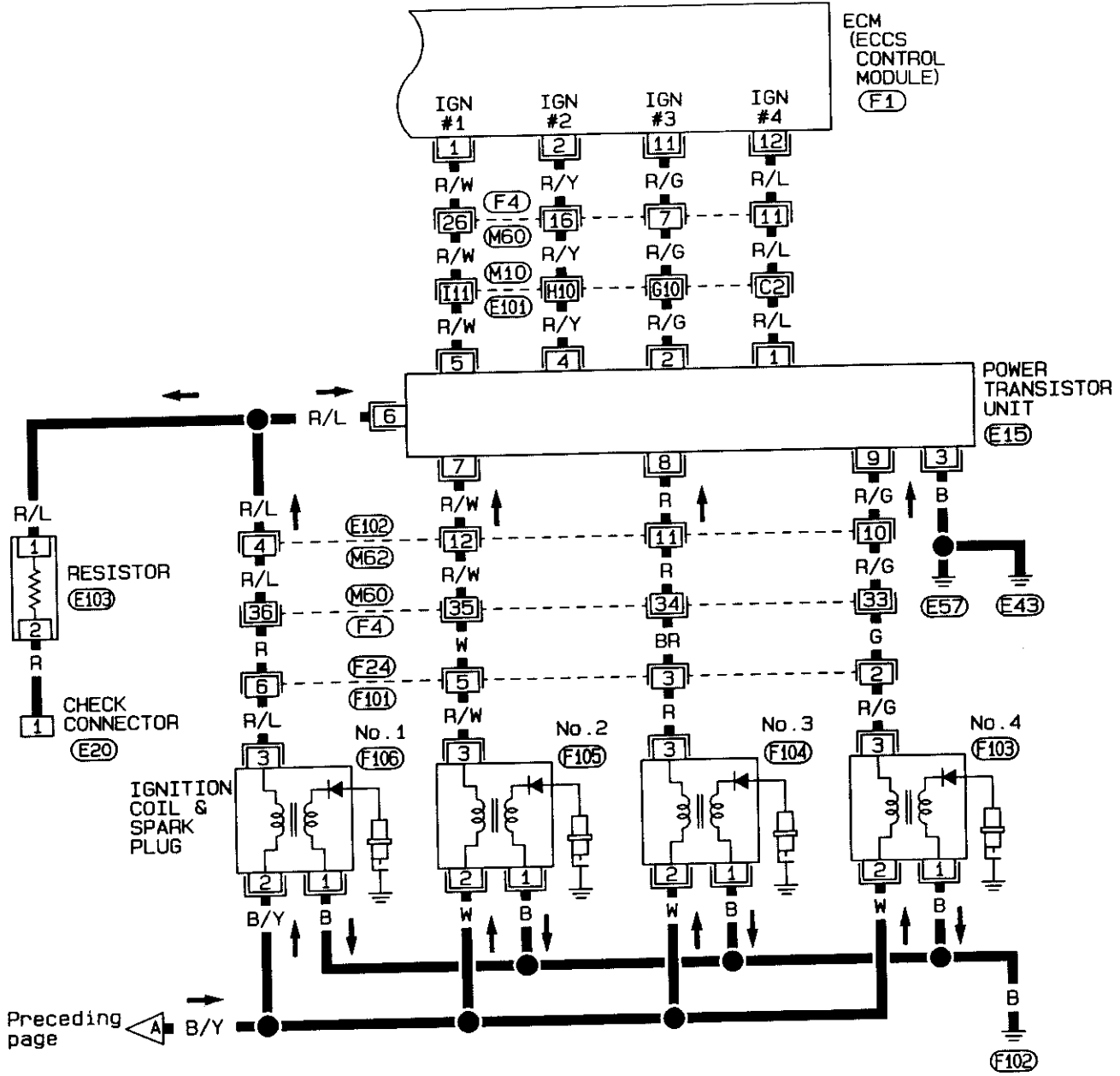

Refer to last page (Foldout page).

M10, E101, M60, F4

101	102	103	104	105	106	107	108	1	2	3	4	5	6	7	8	9	10	21	22	23	24	25	26	27	28	29	30	41	42	43	44	45	46	47	48	49	50
109	110	111	112	113	114	115	116	11	12	13	14	15	16	17	18	19	20	31	32	33	34	35	36	37	38	39	40	51	52	53	54	55	56	57	58	59	60

F1 L H.S.

SEF829P

# TROUBLE DIAGNOSES

## Diagnostic Procedure 26 (Cont'd)

RHD MODELS

EC-IGN/SG-03

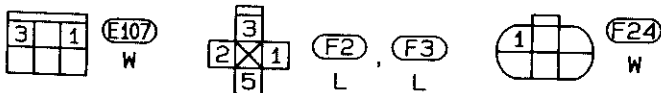
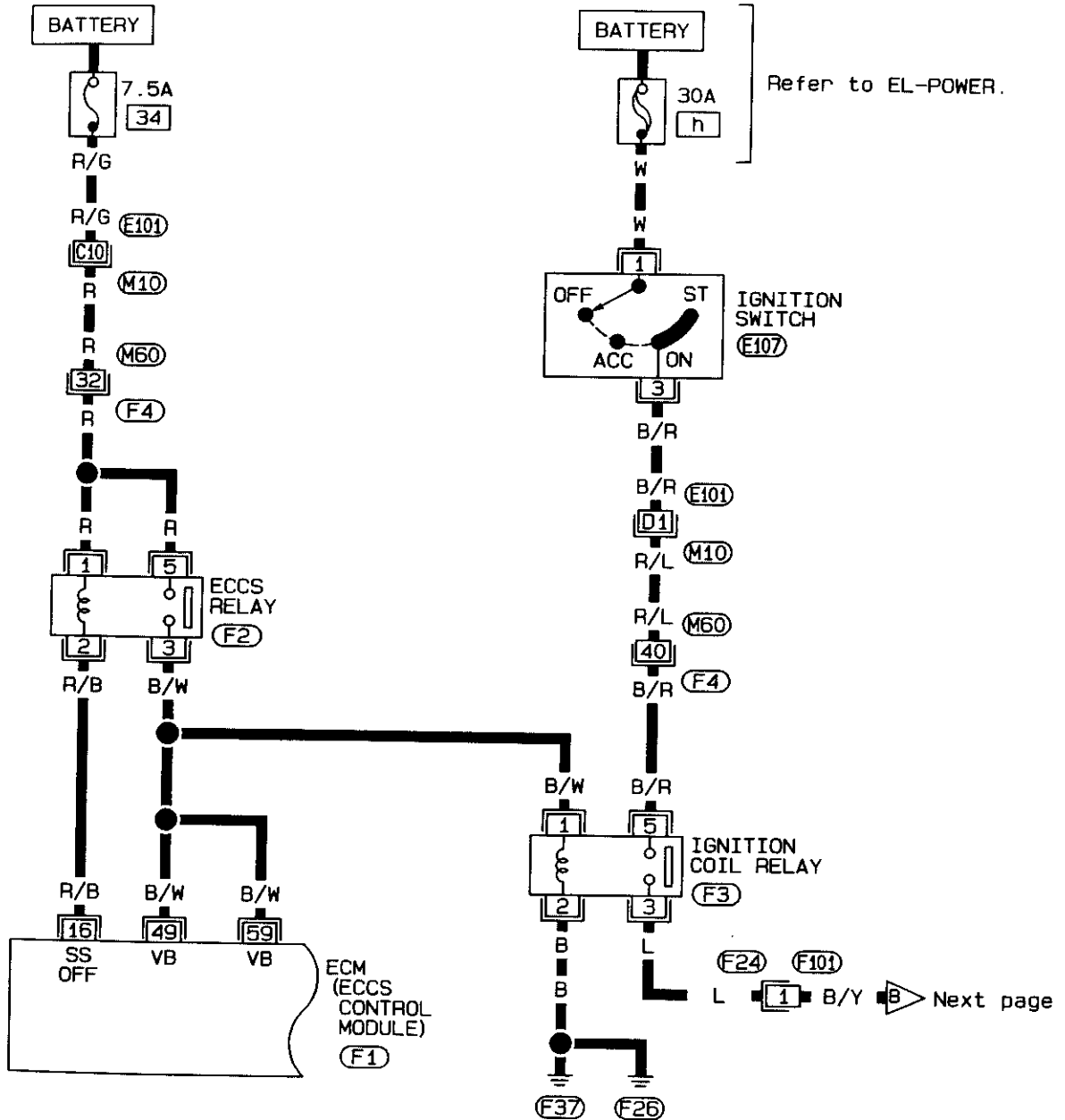

Refer to last page (Foldout page).

(M10), (E101)  
(M60), (F4)

101	102	103	104	105	106	107	108	1	2	3	4	5	6	7	8	9	10	21	22	23	24	25	26	27	28	29	30	41	42	43	44	45	46	47	48	49	50
109	110	111	112	113	114	115	116	11	12	13	14	15	16	17	18	19	20	31	32	33	34	35	36	37	38	39	40	51	52	53	54	55	56	57	58	59	60

(F1)  
L



SEP830P

# TROUBLE DIAGNOSES

## Diagnostic Procedure 26 (Cont'd)

EC-IGN/SG-04

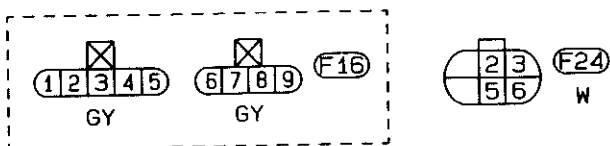
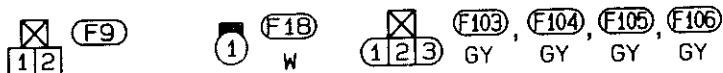
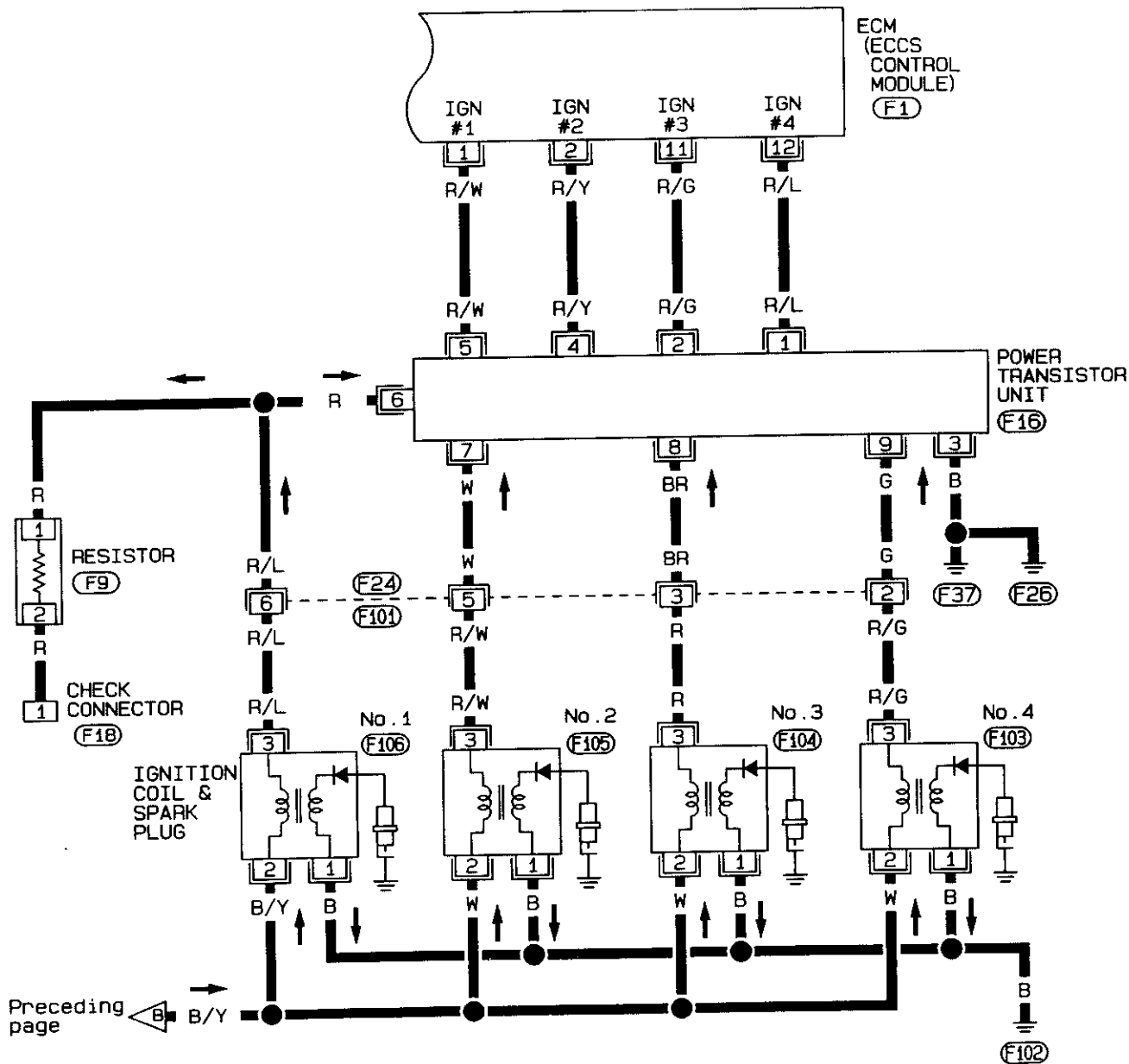

101	102	103	104	105	106	107	108	1	2	3	4	5	6	7	8	9	10	21	22	23	24	25	26	27	28	29	30	41	42	43	44	45	46	47	48	49	50
109	110	111	112	113	114	115	116	11	12	13	14	15	16	17	18	19	20	31	32	33	34	35	36	37	38	39	40	51	52	53	54	55	56	57	58	59	60

(F1)  
L



SEF831P

# TROUBLE DIAGNOSES

## Diagnostic Procedure 26 (Cont'd)

### Harness layout

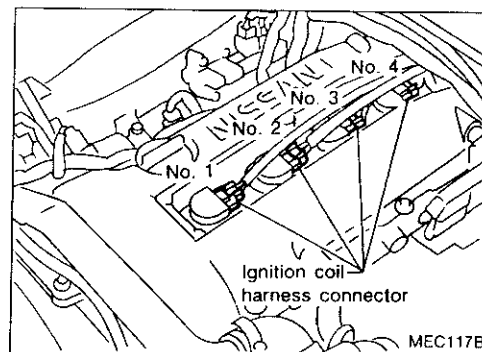
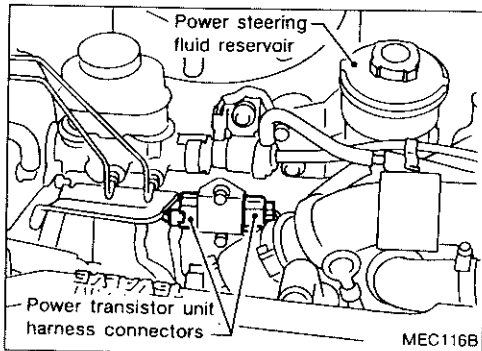
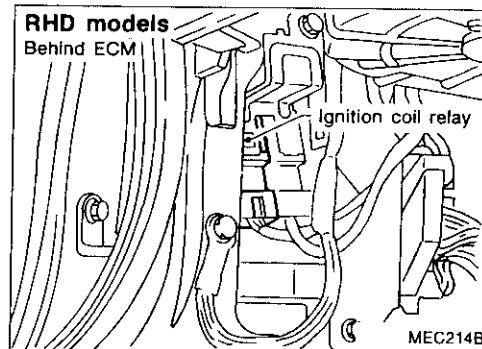
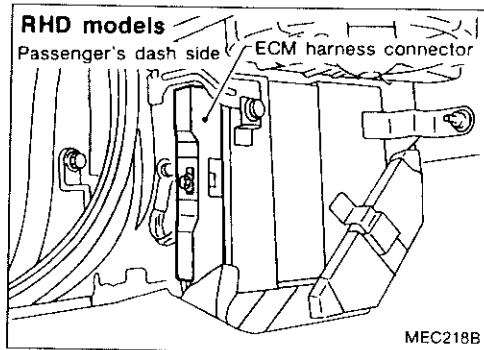
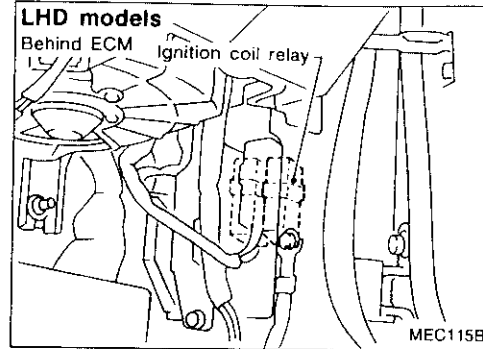
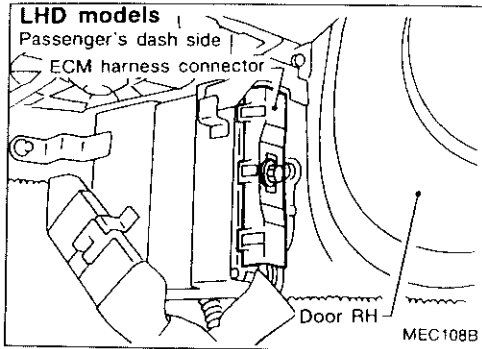

# TROUBLE DIAGNOSES

## Diagnostic Procedure 26 (Cont'd)

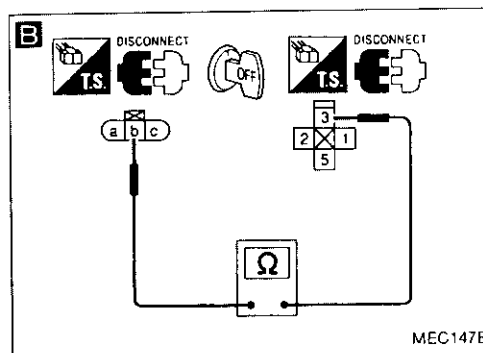
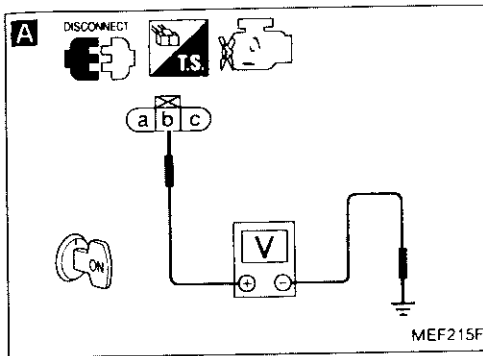

INSPECTION START

**A**  
**CHECK POWER SUPPLY-I.**  
 1) Disconnect ignition coil harness connectors.  
 2) Turn ignition switch "ON".  
 3) Check voltage between terminal (b) and ground.  
**Voltage: Battery voltage**

OK → Go to "CHECK GROUND CIRCUIT-II" on next page.

**B**  
**CHECK POWER SUPPLY-II.**  
 1) Turn ignition switch "OFF".  
 2) Disconnect ignition coil relay.  
 3) Check harness continuity between terminal (b) and terminal (3).  
**Continuity should exist.**

NG → Check the following  
 • Harness connectors (F24, F101)  
 • Harness continuity between ignition coil and ignition coil relay  
 If NG, repair harness or connectors.

**C**  
**CHECK POWER SUPPLY-III.**  
 1) Turn ignition switch "ON".  
 2) Check voltage between terminals (a) and ground.

NG → Check the following.  
 • Harness connectors (E101, M10)  
 • Harness connectors

SI  
 MA  
 FM  
 LC  
 EC  
 FE  
 CL  
 MT

# TROUBLE DIAGNOSES

## Diagnostic Procedure 26 (Cont'd)

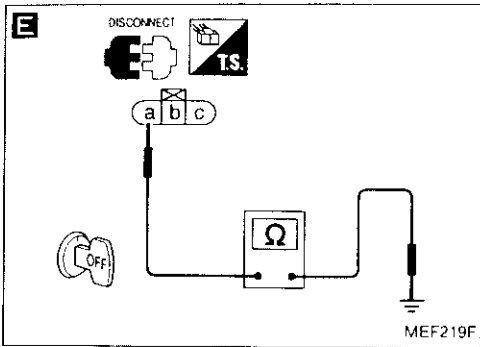

### CHECK GROUND CIRCUIT-II.

1) Turn ignition switch "OFF".

**E** 2) Check harness continuity between terminal (a) and engine ground.  
**Continuity should exist.**

3) Disconnect power transistor unit harness connector.

**F** 4) Check harness continuity between terminal (f) and engine ground.  
**Continuity should exist.**

NG

Repair harness or connectors.

OK

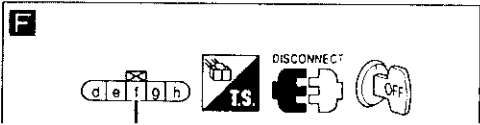

### CHECK OUTPUT SIGNAL CIRCUIT.

**G** 1) Check harness continuity between terminals (i), (j), (k)

NG

Check the following.  
• Harness connectors (F24) (F101)



# TROUBLE DIAGNOSES

## Diagnostic Procedure 26 (Cont'd)

Perform FINAL CHECK by the following procedure after repair is completed.

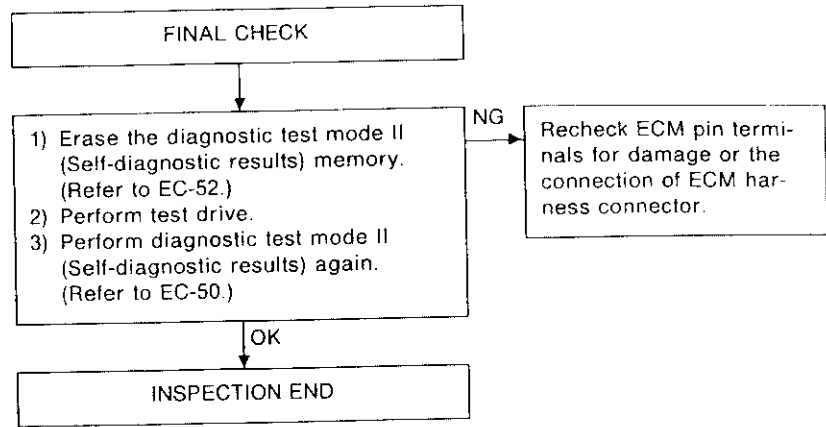

41  
42  
43  
44  
45  
46  
47  
48  
49  
50  
51  
52  
53  
54  
55  
56  
57  
58  
59  
60  
61  
62  
63  
64  
65  
66  
67  
68  
69  
70  
71  
72  
73  
74  
75  
76  
77  
78  
79  
80  
81  
82  
83  
84  
85  
86  
87  
88  
89  
90  
91  
92  
93  
94  
95  
96  
97  
98  
99  
100

# TROUBLE DIAGNOSES

## Diagnostic Procedure 27

### BOOST PRESSURE SENSOR (Diagnostic trouble code No. 26)

EC-BOOST-01

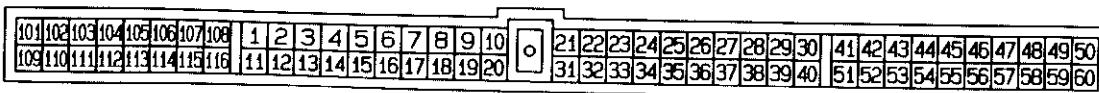
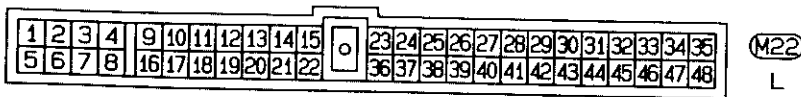
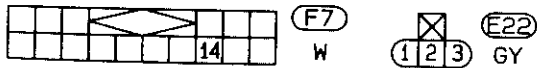
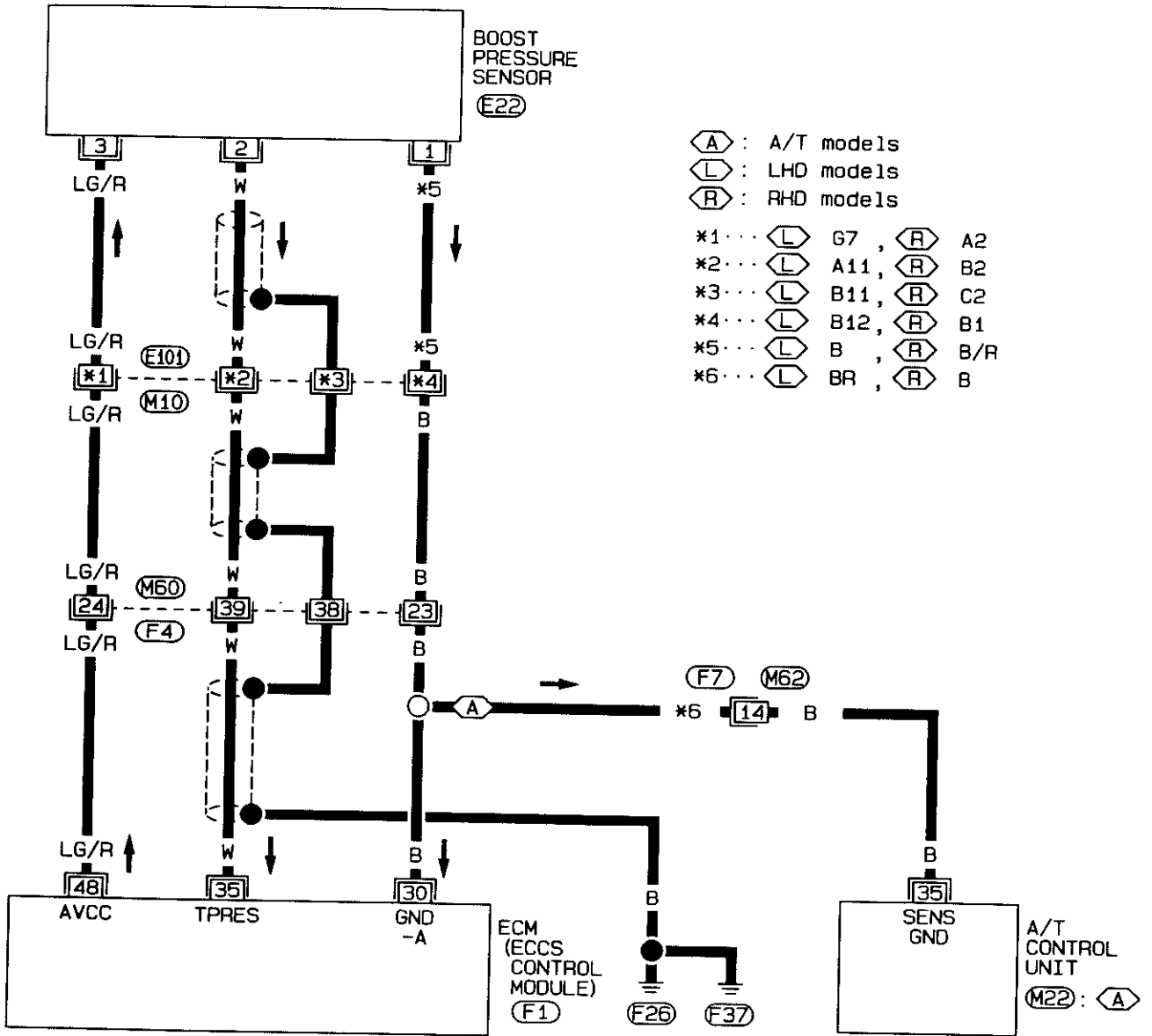

Refer to last page (Foldout page).

(M10), (E101)  
(M60), (F4)

(F1)  
L



SEF838P



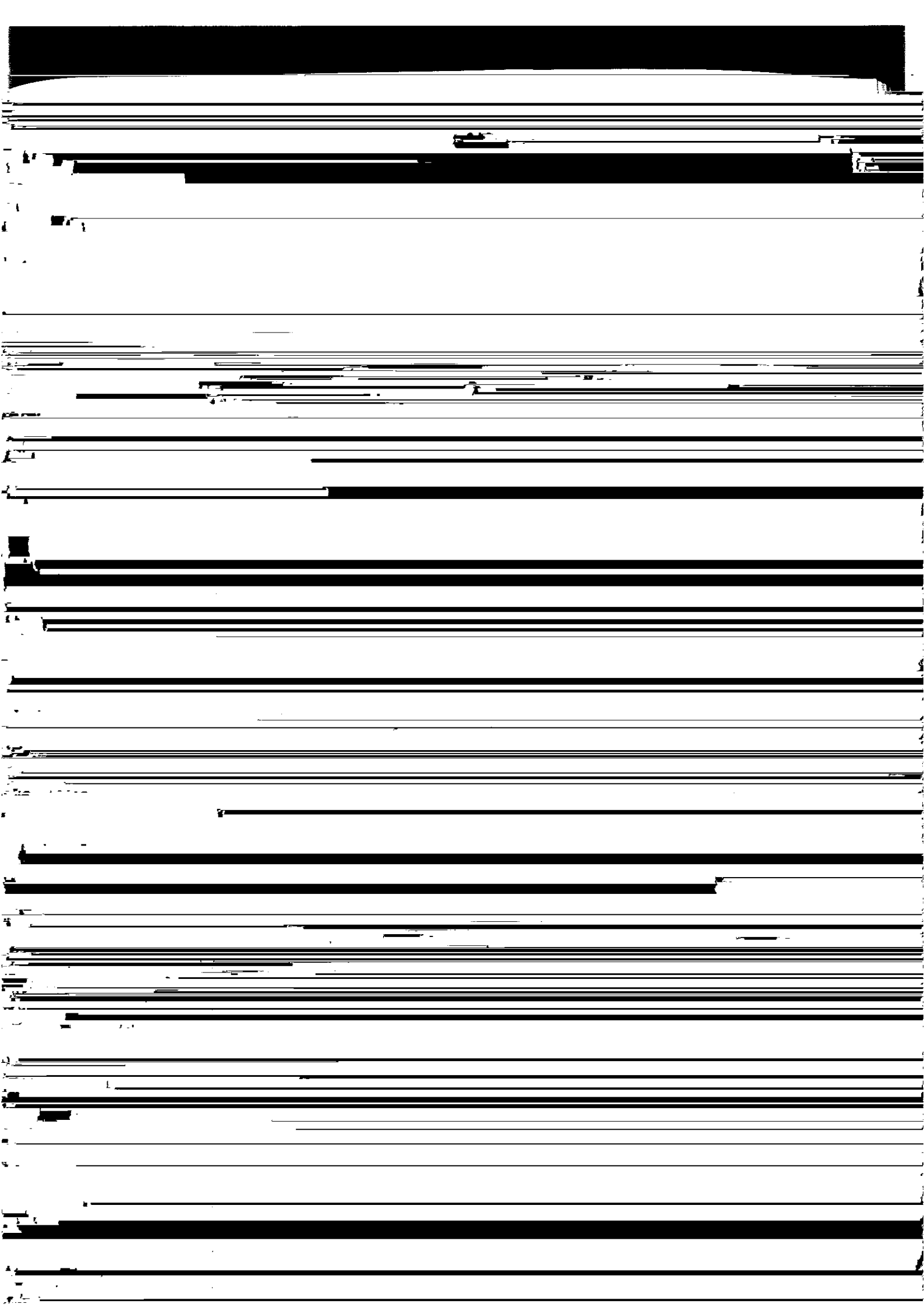

# TROUBLE DIAGNOSES

## Diagnostic Procedure 27 (Cont'd)

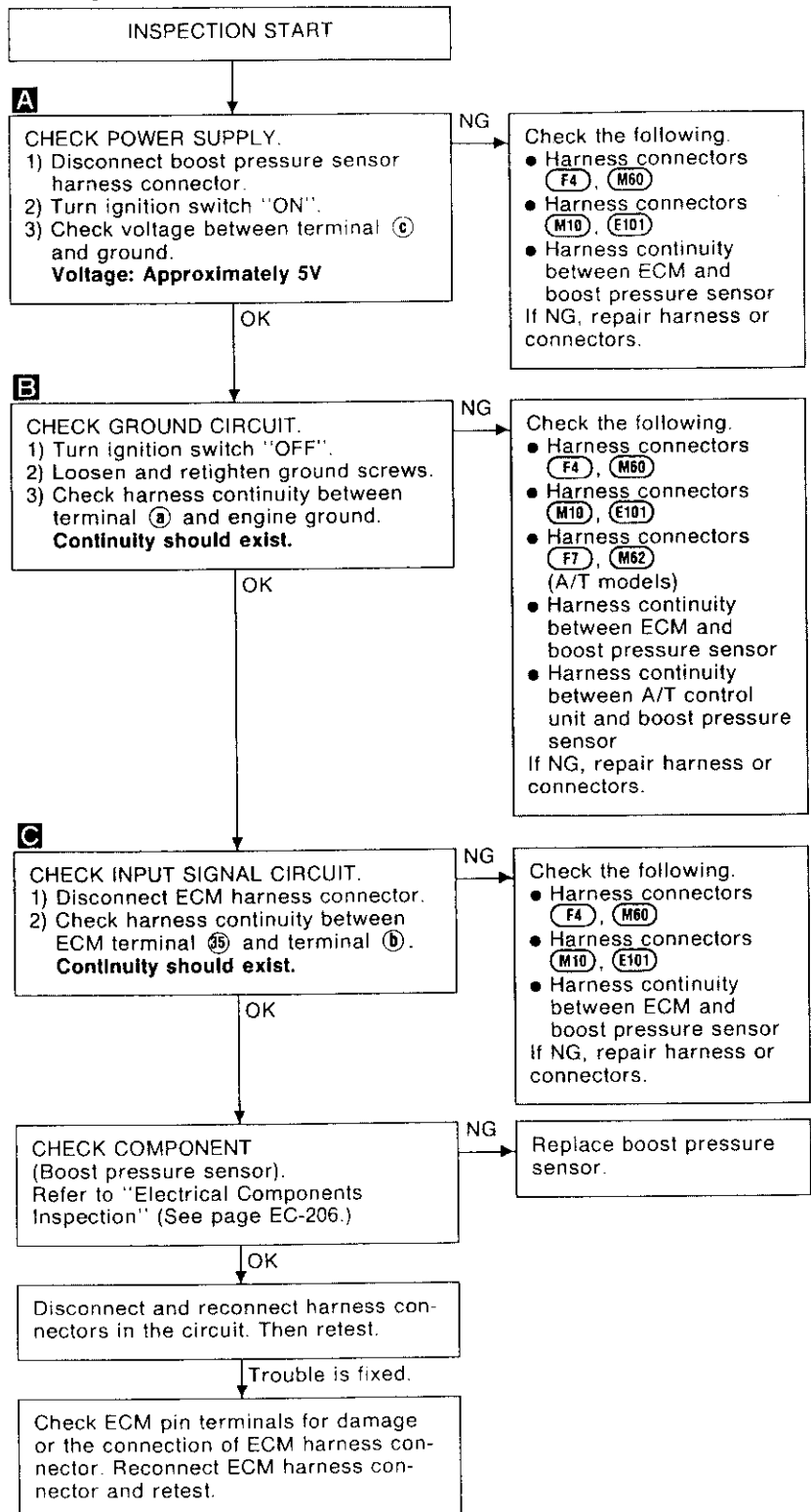
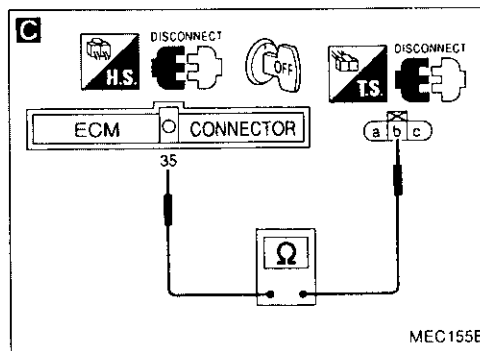
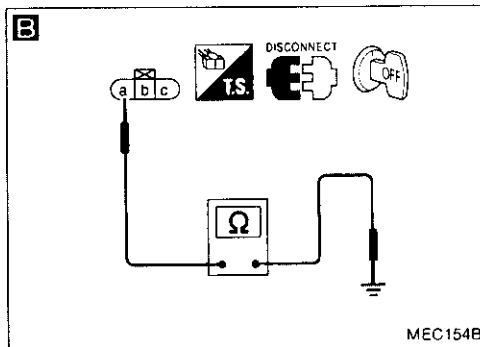
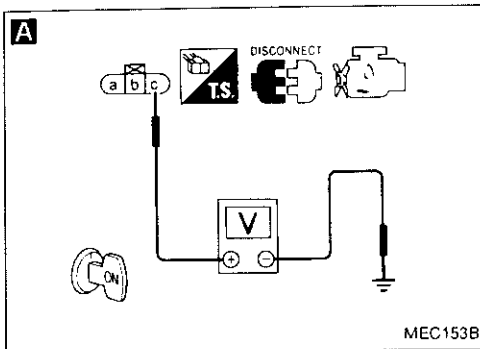

# TROUBLE DIAGNOSES

## Diagnostic Procedure 27 (Cont'd)

Perform FINAL CHECK by the following procedure after repair is completed.

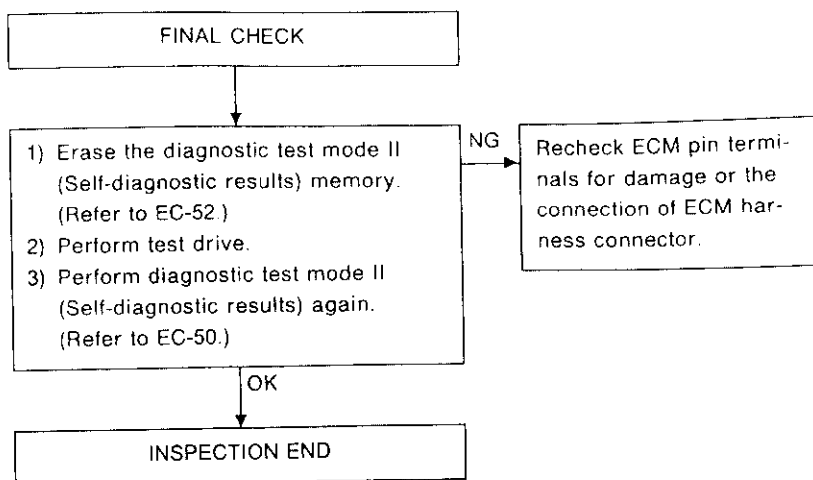

CI

MA

MI

LC

**EC**

EE

CL

MT

AT

PD

EA

EA

EP

ST

PS

BT

HA

EL

IDX

# TROUBLE DIAGNOSES

## Diagnostic Procedure 28

**KNOCK SENSOR (Diagnostic trouble code No. 34)**

EC-KS-01

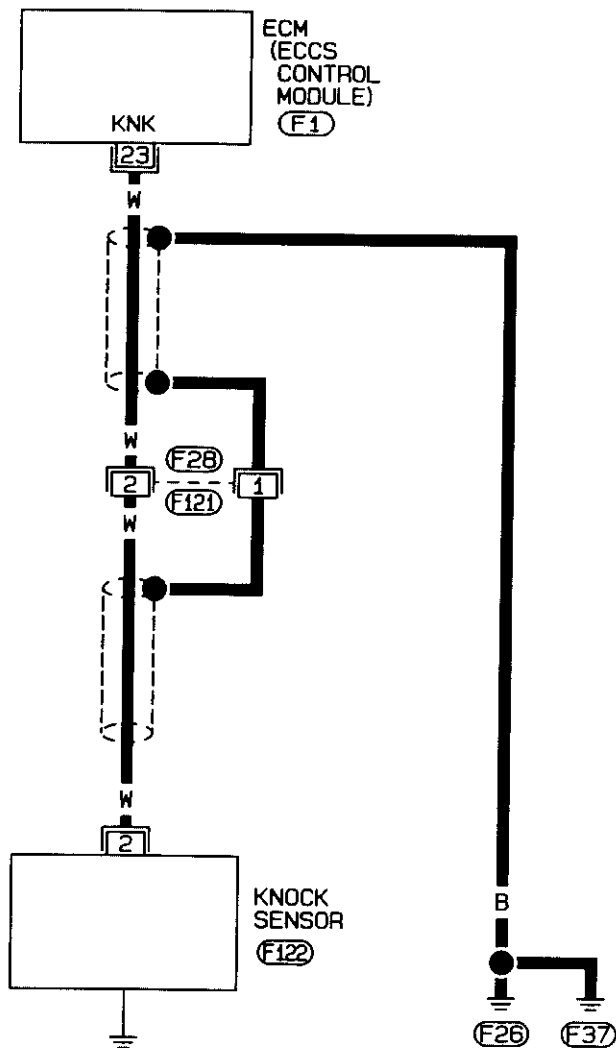

101	102	103	104	105	106	107	108	1	2	3	4	5	6	7	8	9	10	21	22	23	24	25	26	27	28	29	30	41	42	43	44	45	46	47	48	49	50
109	110	111	112	113	114	115	116	11	12	13	14	15	16	17	18	19	20	31	32	33	34	35	36	37	38	39	40	51	52	53	54	55	56	57	58	59	60

(F1)  
L



SEF836P

# TROUBLE DIAGNOSES

## Diagnostic Procedure 28 (Cont'd)

### Harness layout

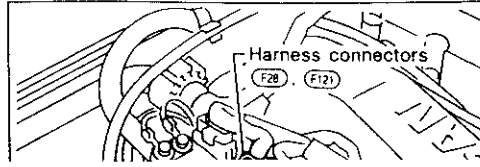
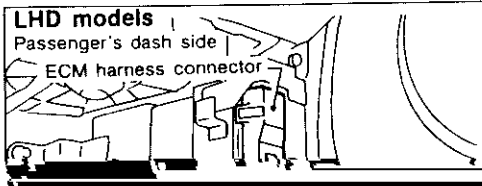

GI

MA

## TROUBLE DIAGNOSES

### Diagnostic Procedure 28 (Cont'd)

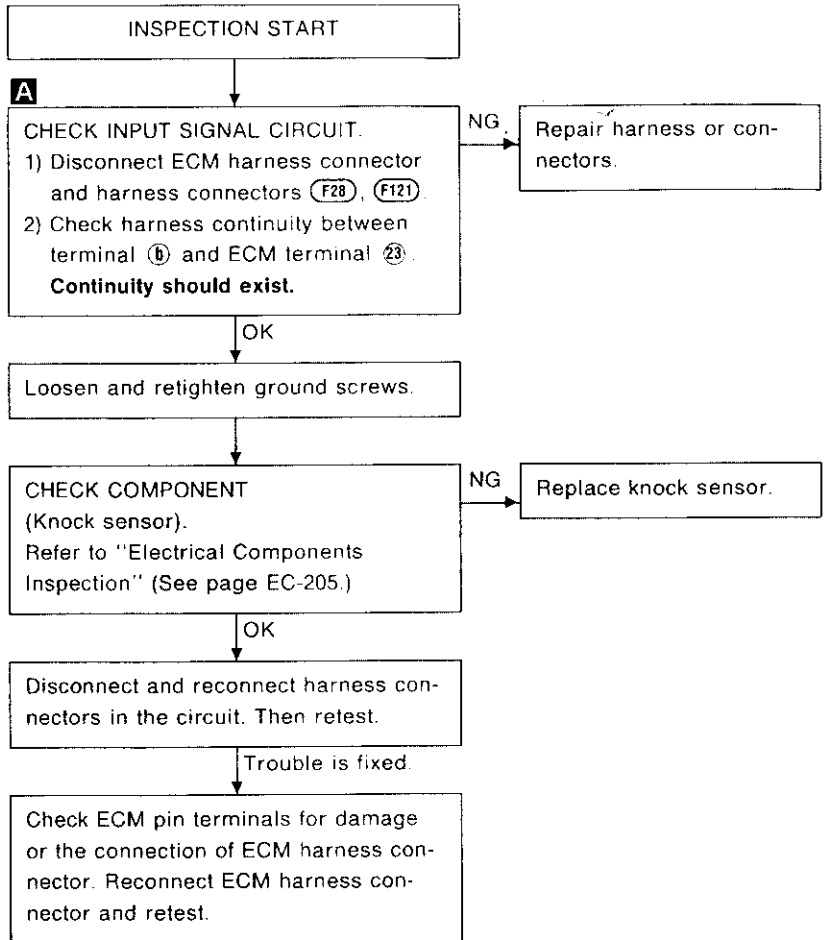
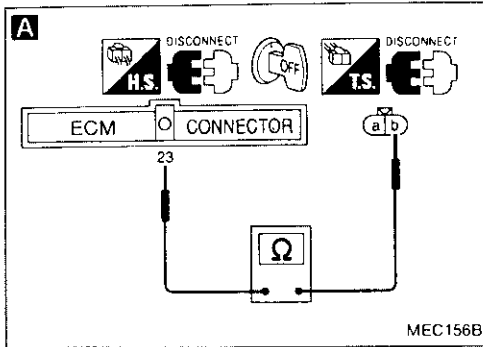

**Perform FINAL CHECK by the following procedure after repair is completed.**

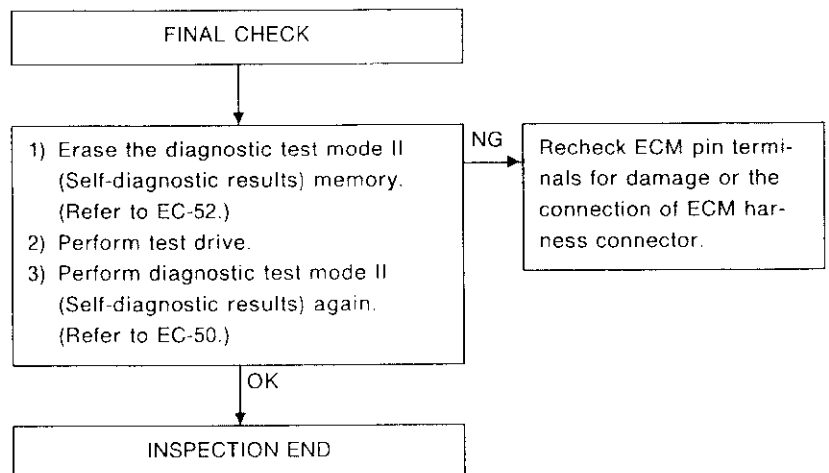

# TROUBLE DIAGNOSES

## Diagnostic Procedure 29

### THROTTLE POSITION SENSOR (Diagnostic trouble code No. 43)

EC-TPS-01

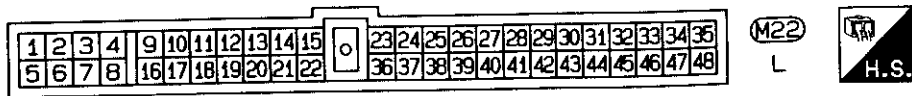
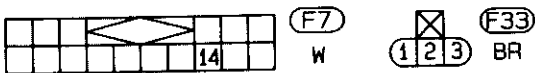
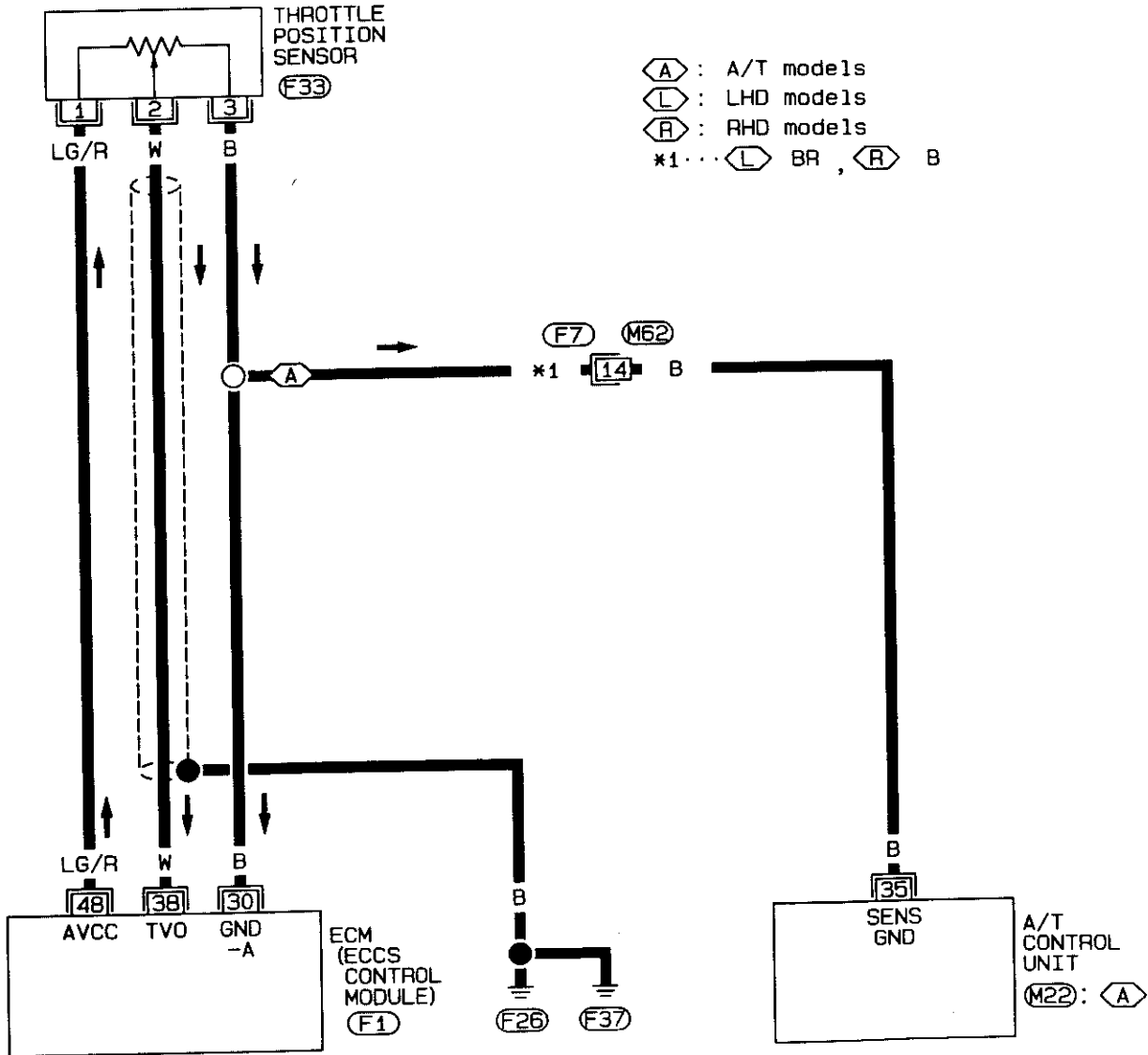

SEF835P

# TROUBLE DIAGNOSES

## Diagnostic Procedure 29 (Cont'd)

### Harness layout

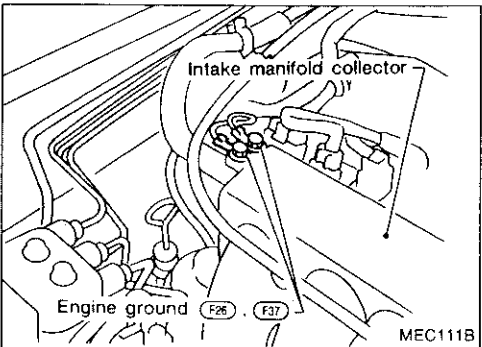
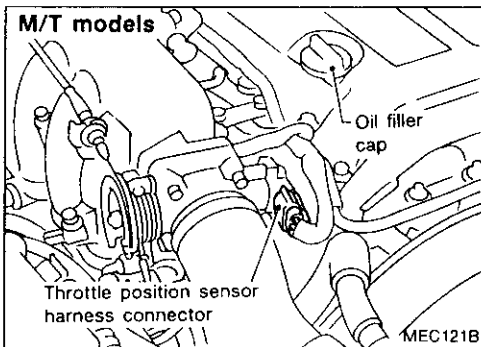
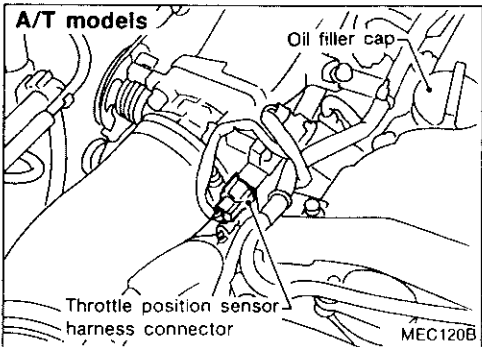
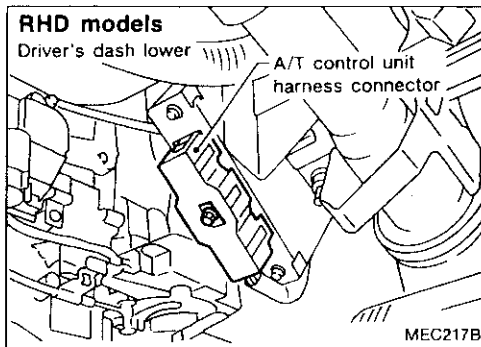
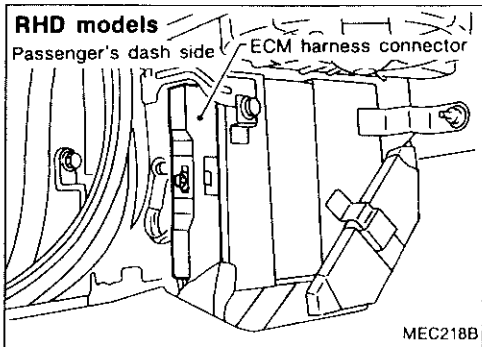
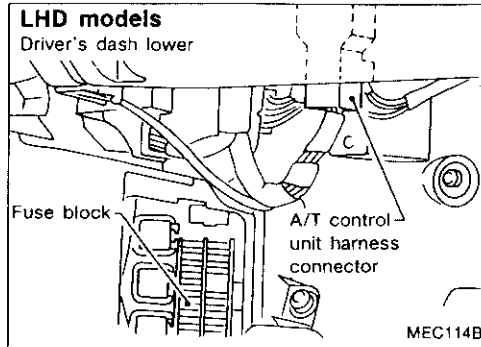
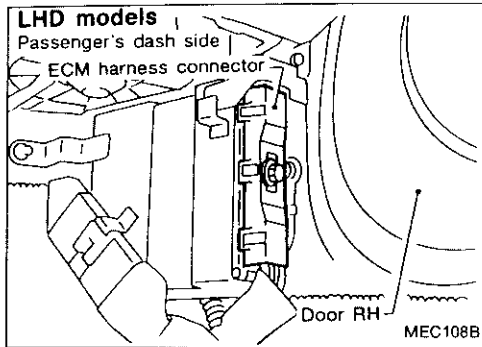



# TROUBLE DIAGNOSES

## Diagnostic Procedure 29 (Cont'd)

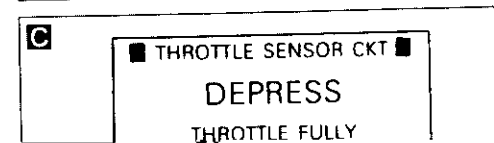
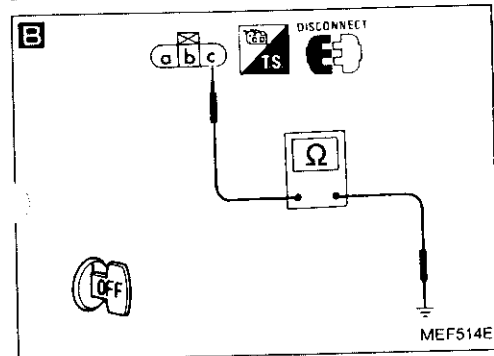
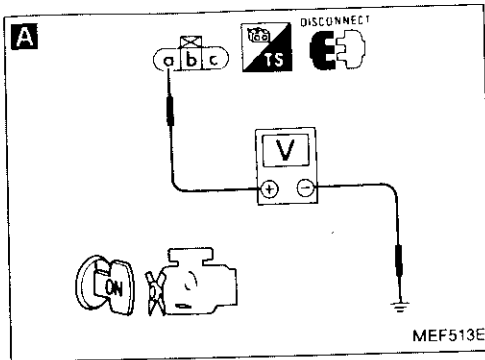

INSPECTION START

**A**

**CHECK POWER SUPPLY.**

- 1) Disconnect throttle position sensor harness connector.
- 2) Turn ignition switch "ON".
- 3) Check voltage between terminal (a) and ground.

**Voltage: Approximately 5V**

NG → Repair harness or connectors.

OK

**B**

**CHECK GROUND CIRCUIT.**

- 1) Turn ignition switch "OFF".
- 2) Loosen and retighten ground screws.
- 3) Check harness continuity between terminal (c) and engine ground.

**Continuity should exist.**

NG → Check the following.

- Harness connectors (F7), (M62) (A/T models)
- Harness continuity between ECM and throttle position sensor
- Harness continuity between A/T control unit and throttle position sensor

If NG, repair harness or connectors.

OK

**C**

**CHECK INPUT SIGNAL CIRCUIT.**

(Check throttle position)

NG → Repair harness or connectors.

EC  
FE  
CL  
MT  
AT

## TROUBLE DIAGNOSES

### Diagnostic Procedure 29 (Cont'd)

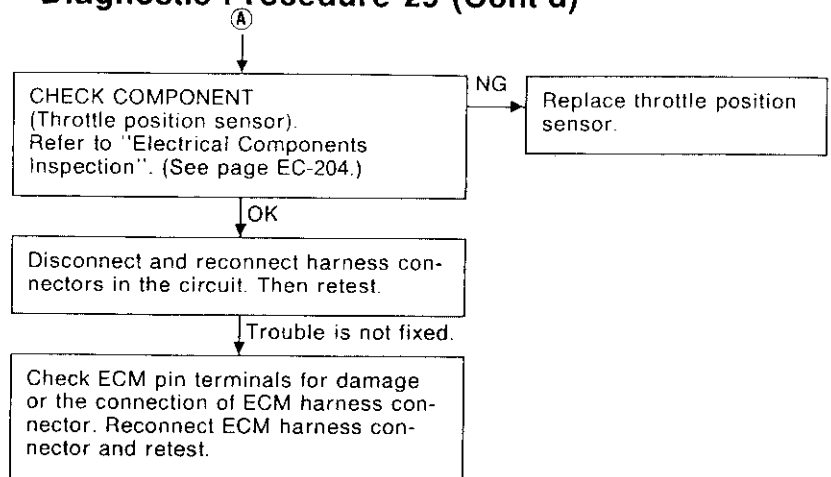

**Perform FINAL CHECK by the following procedure after repair is completed.**

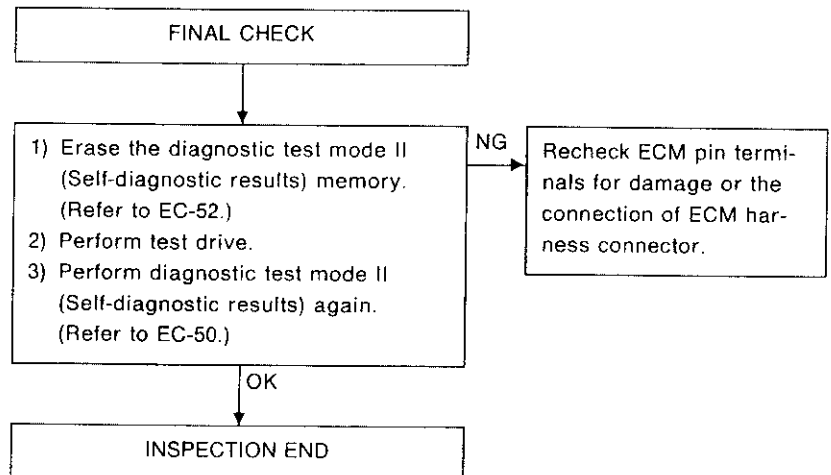

# TROUBLE DIAGNOSES

## Diagnostic Procedure 30

A/T CONTROL (Diagnostic trouble code No. 54)

EC-AT/C-01

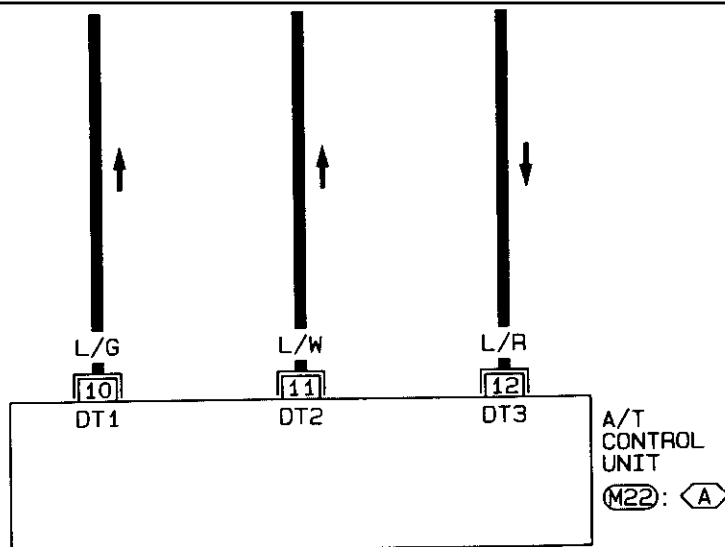
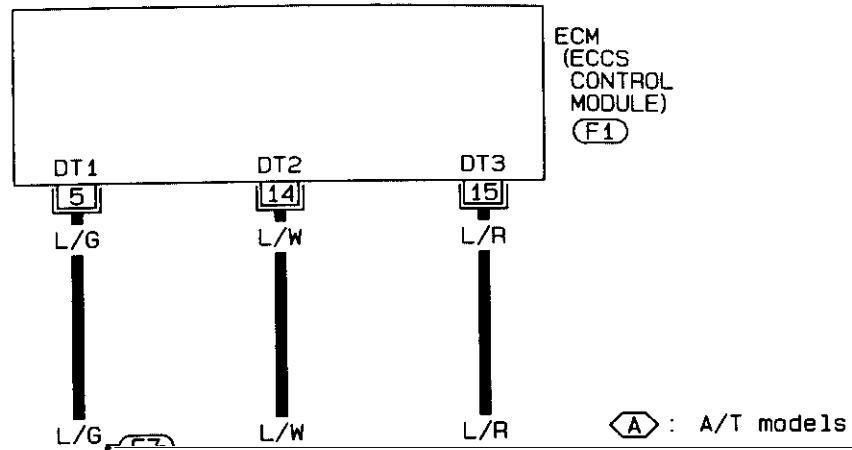

# TROUBLE DIAGNOSES

## Diagnostic Procedure 30 (Cont'd)

### Harness layout

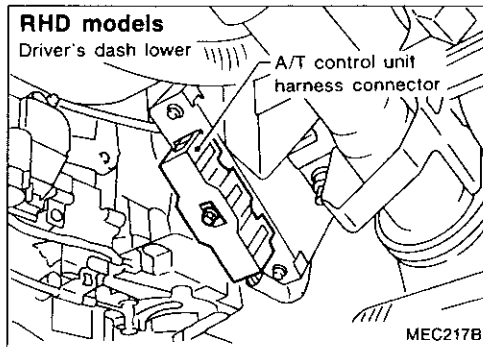
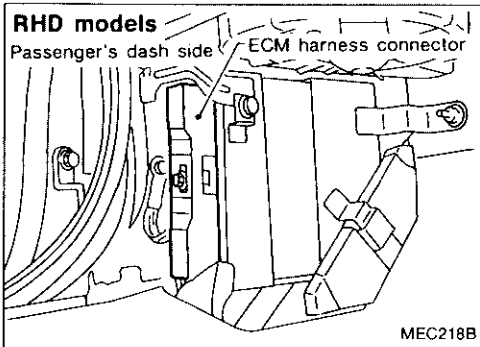
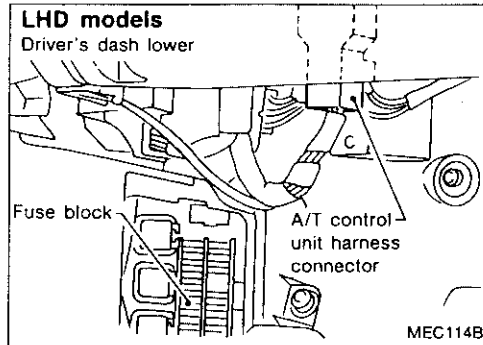
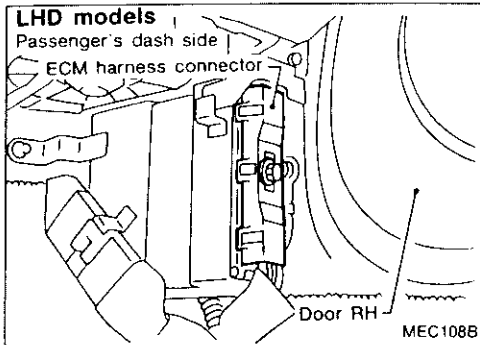

# TROUBLE DIAGNOSES

## Diagnostic Procedure 30 (Cont'd)

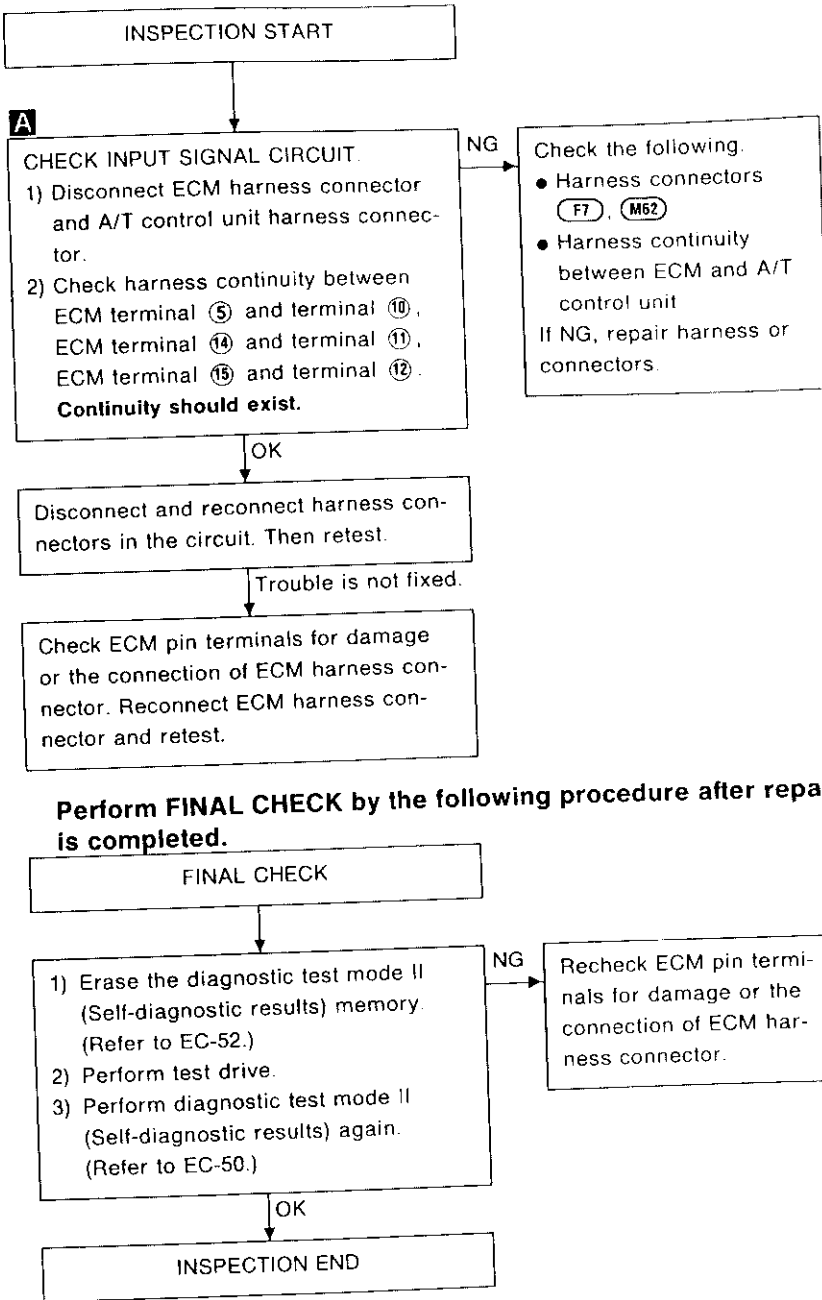
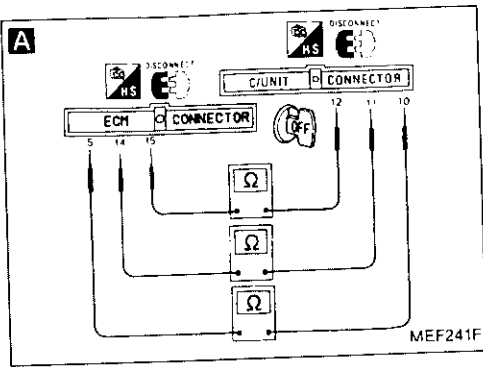

# TROUBLE DIAGNOSES

## Diagnostic Procedure 31

START SIGNAL (Not self-diagnostic item)

EC-S/SIG-01

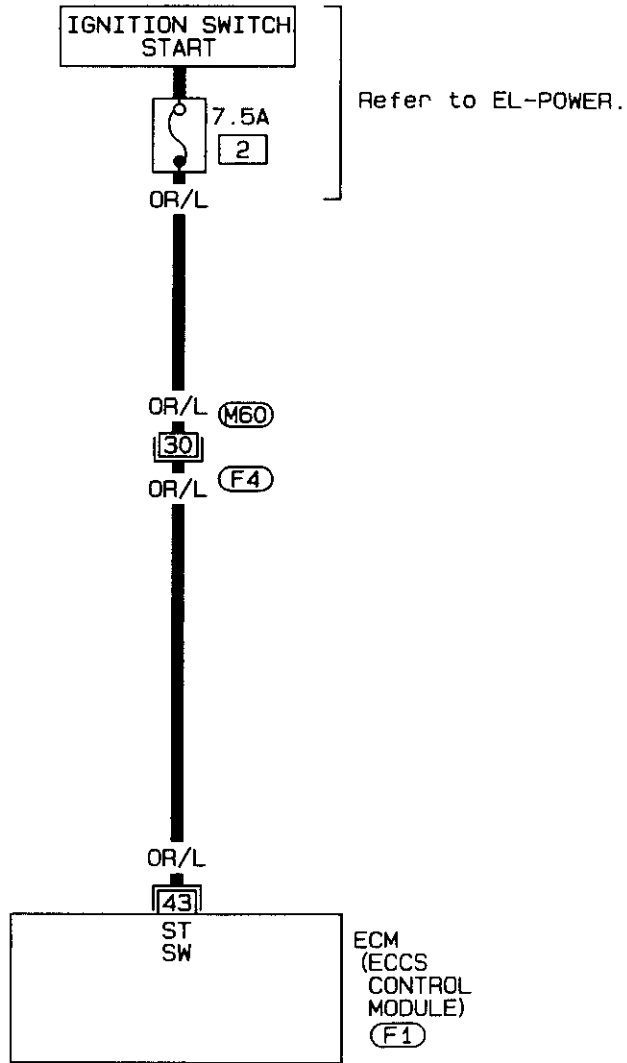

Refer to last page  
(Foldout page).

(M60) (F4)

101	102	103	104	105	106	107	108	1	2	3	4	5	6	7	8	9	10	21	22	23	24	25	26	27	28	29	30	41	42	43	44	45	46	47	48	49	50
109	110	111	112	113	114	115	116	11	12	13	14	15	16	17	18	19	20	31	32	33	34	35	36	37	38	39	40	51	52	53	54	55	56	57	58	59	60

(F1)  
L



SEF844P

# TROUBLE DIAGNOSES

## Diagnostic Procedure 31 (Cont'd)

### Harness layout

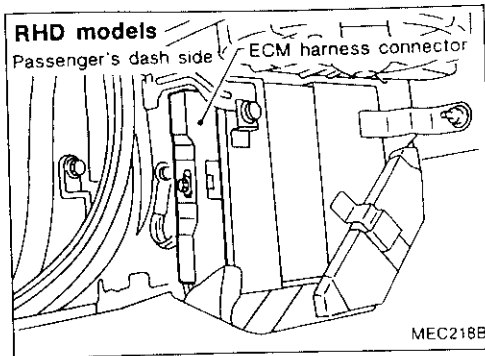
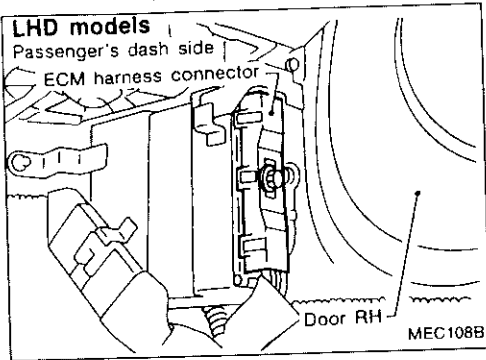

**A**

■ **START SIGNAL CKT** ■

1. CLOSE THROTTLE. SHIFT TO P OR N RANGE.
2. TOUCH START AND START ENGINE IMMEDIATELY.

NEXT    START

MEF481B

**A**

☆ MONITOR ☆ NO FAIL

START SIGNAL	OFF
IDLE POSITION	ON
AIR COND SIG	OFF
NEUTRAL SW	ON

RECORD

SEF384J

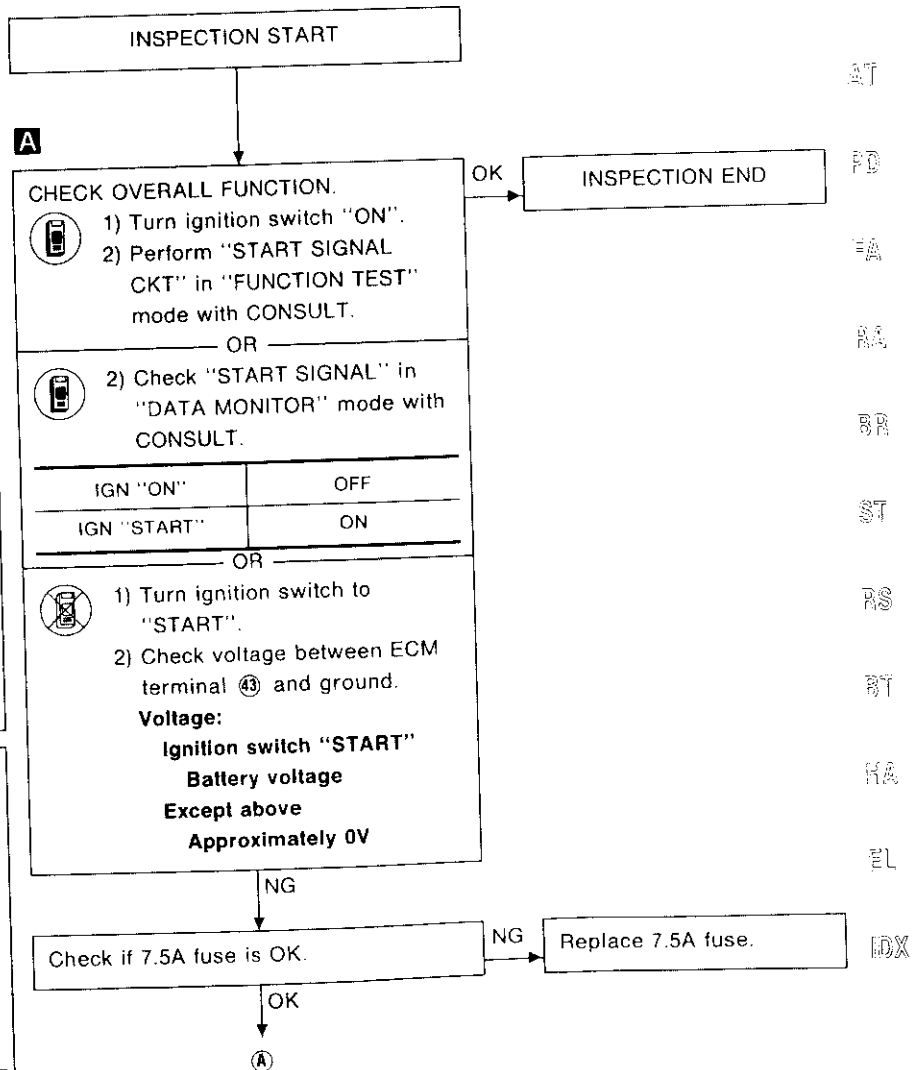
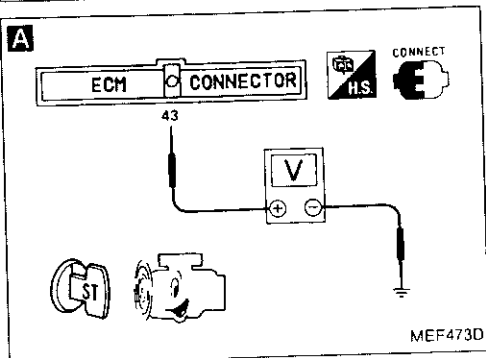

## TROUBLE DIAGNOSES

### Diagnostic Procedure 31 (Cont'd)

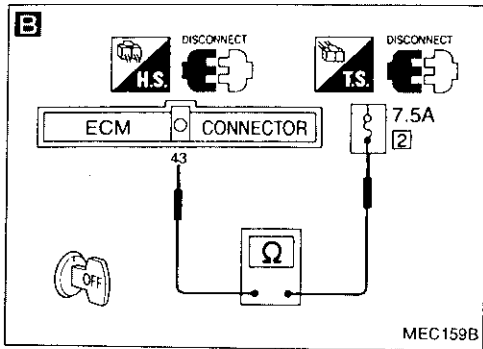

**B**

**CHECK INPUT SIGNAL CIRCUIT.**  
1) Turn ignition switch "OFF".  
2) Disconnect ECM harness connector and 7.5A fuse.  
3) Check harness continuity between ECM terminal ④ and fuse block.  
**Continuity should exist.**

NG

Check the following.

- Harness connectors  
    ④, ⑥
- Harness continuity between ECM and fuse block

If NG, repair harness or connectors.

OK

Disconnect and reconnect harness connectors in the circuit. Then retest.

Trouble is not fixed.

Check ECM pin terminals for damage or the connection of ECM harness connector. Reconnect ECM harness connector and retest.



# TROUBLE DIAGNOSES

## Diagnostic Procedure 32

### VEHICLE SPEED SENSOR (Not self-diagnostic item)

EC-VSS-01

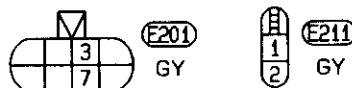
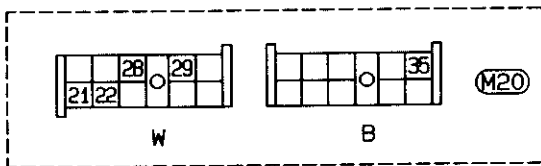
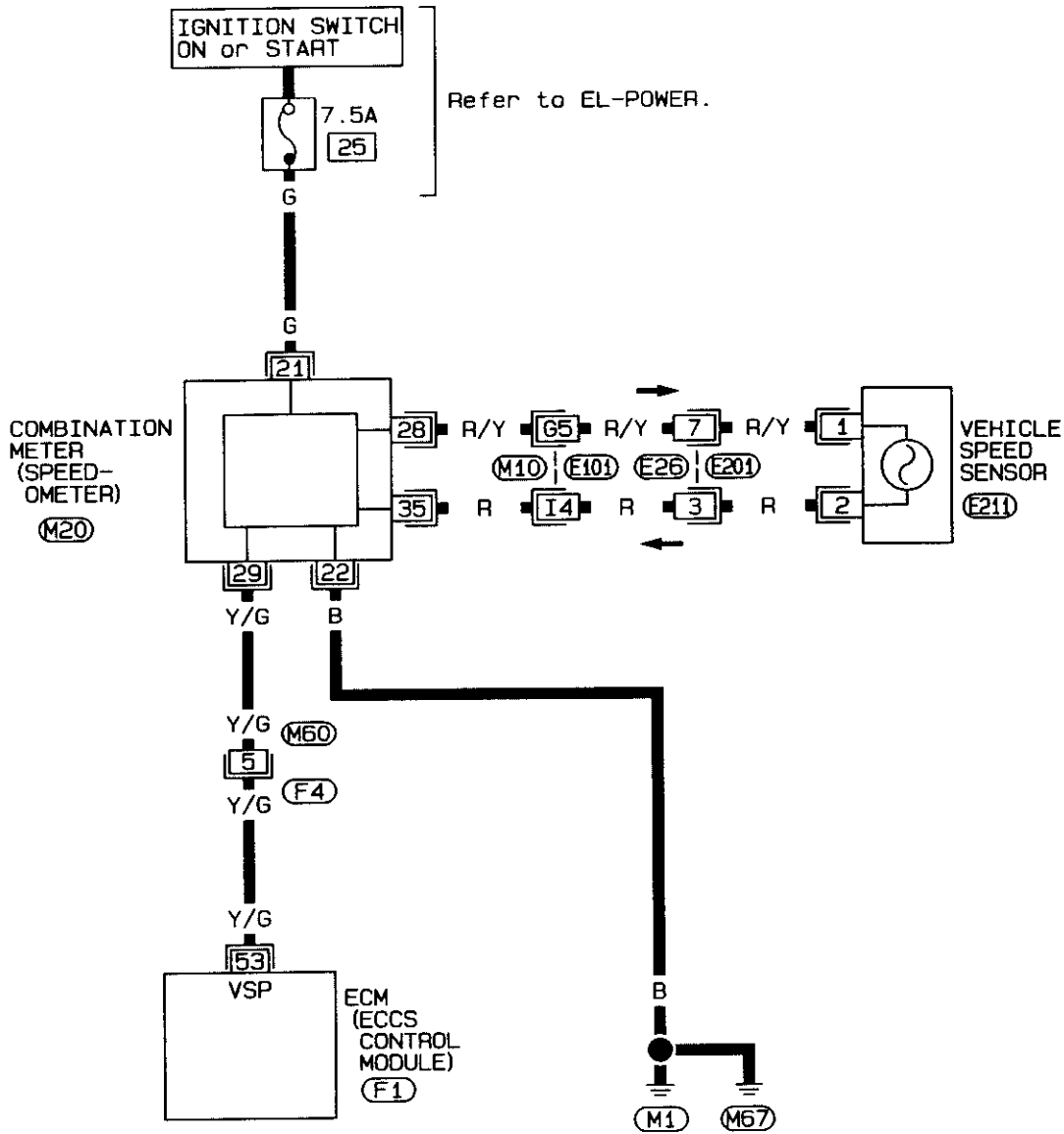

Refer to last page (Foldout page).

M10 E101  
M60 F4

101	102	103	104	105	106	107	108	1	2	3	4	5	6	7	8	9	10	21	22	23	24	25	26	27	28	29	30	41	42	43	44	45	46	47	48	49	50
109	110	111	112	113	114	115	116	11	12	13	14	15	16	17	18	19	20	31	32	33	34	35	36	37	38	39	40	51	52	53	54	55	56	57	58	59	60

F1  
L



SEF837P

# TROUBLE DIAGNOSES

## Harness layout

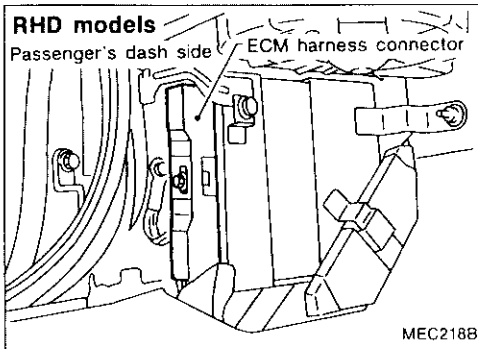
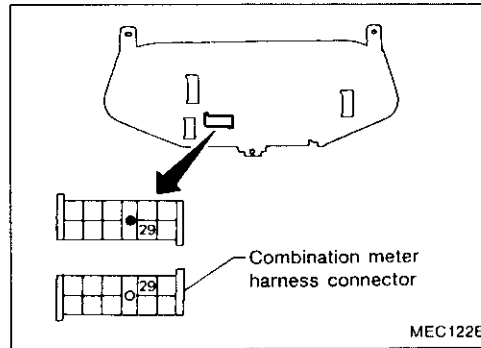
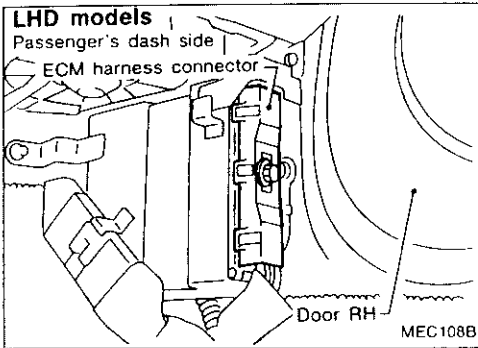

# TROUBLE DIAGNOSES

## Diagnostic Procedure 32 (Cont'd)

**A**

■ CAR SPEED SEN CIRCUIT ■

AFTER TOUCH START,  
DRIVE VEHICLE  
AT 10 km/h (6 mph) OR  
MORE WITHIN 15 sec

NEXT    START

SEF631L

**A**

☆ MONITOR ☆ NO FAIL

CAR SPEED SEN    0mph

RECORD

SEF5871

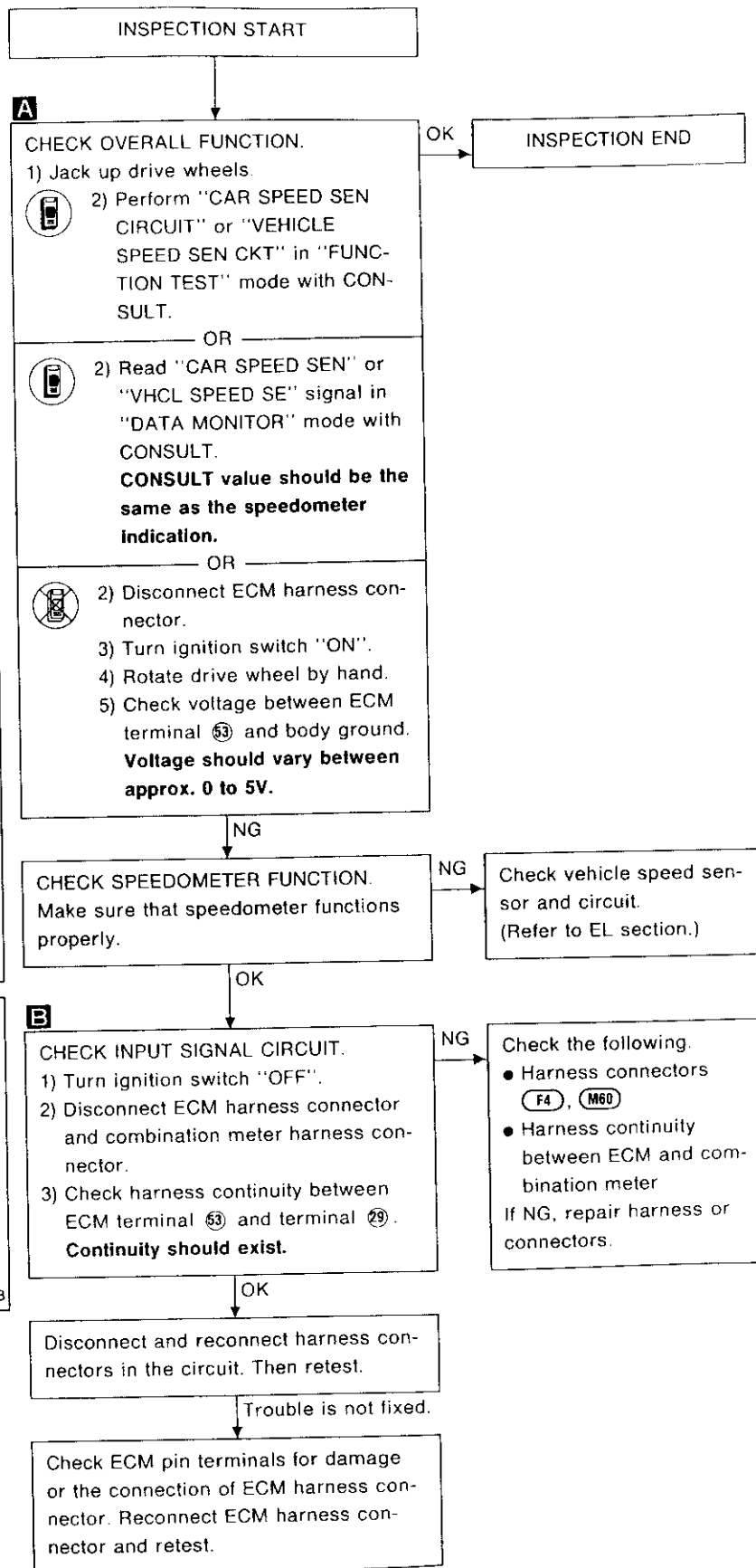
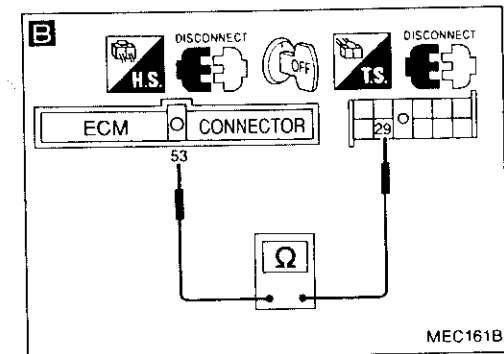
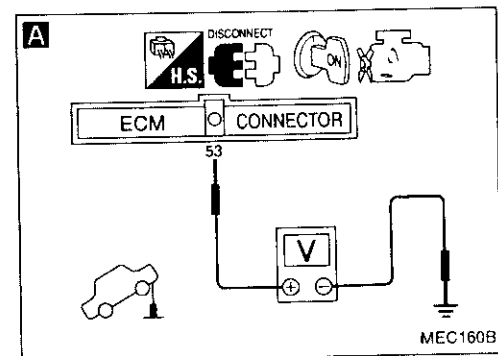

# TROUBLE DIAGNOSES

## Diagnostic Procedure 33

### EGR AND CANISTER CONTROL (Not self-diagnostic item)

EC-EGRC/V-01

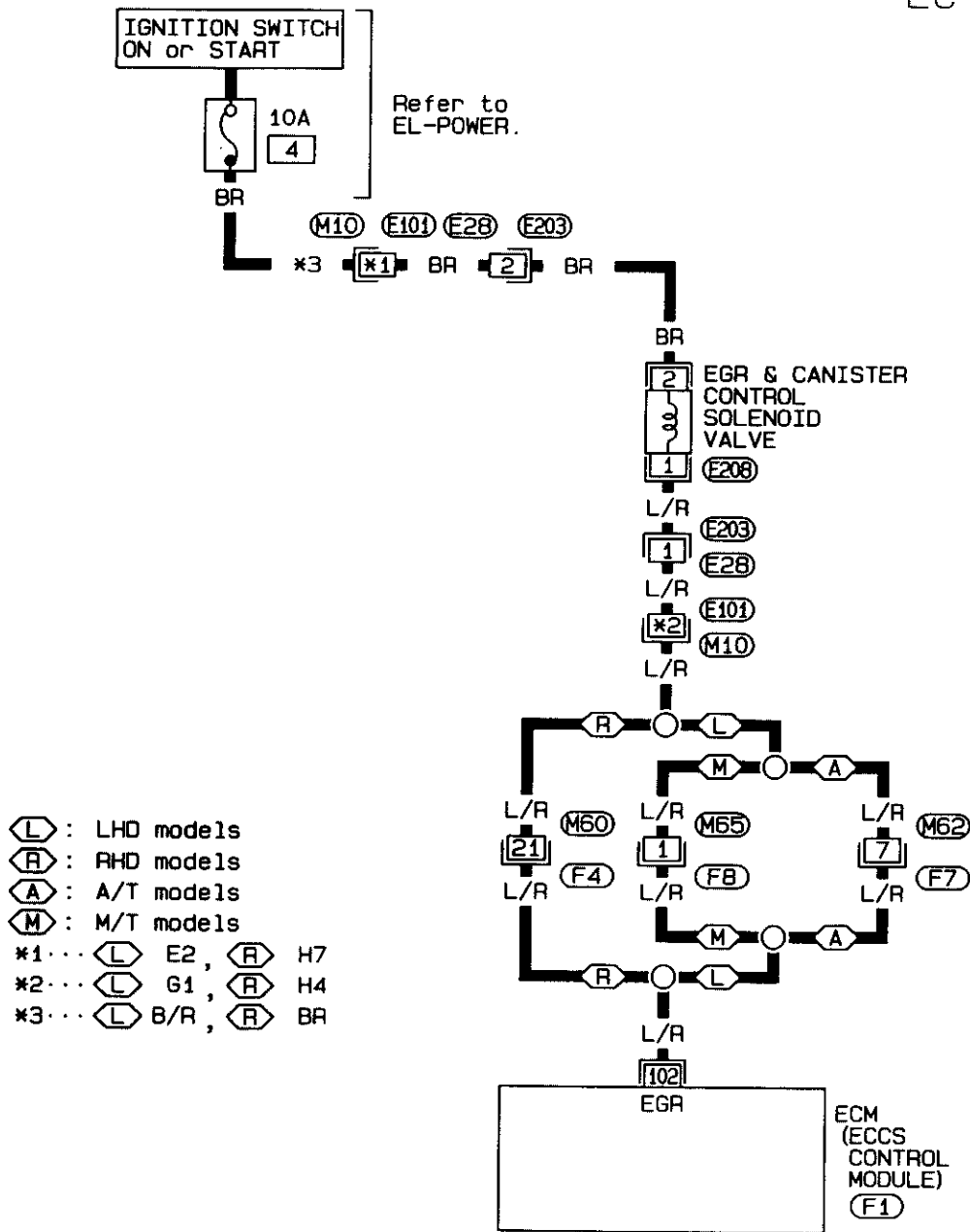

- (L) : LHD models
- (R) : RHD models
- (A) : A/T models
- (M) : M/T models
- \*1... (L) E2, (R) H7
- \*2... (L) G1, (R) H4
- \*3... (L) B/R, (R) BR

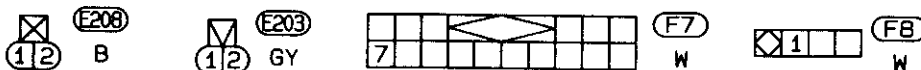

Refer to last page (Foldout page).

- (M10), (E101)
- (M60), (F4)

101	102	103	104	105	106	107	108	1	2	3	4	5	6	7	8	9	10	21	22	23	24	25	26	27	28	29	30	41	42	43	44	45	46	47	48	49	50
109	110	111	112	113	114	115	116	11	12	13	14	15	16	17	18	19	20	31	32	33	34	35	36	37	38	39	40	51	52	53	54	55	56	57	58	59	60

(F1)  
L



SEF832P

# TROUBLE DIAGNOSES

## Diagnostic Procedure 33 (Cont'd)

### Harness layout

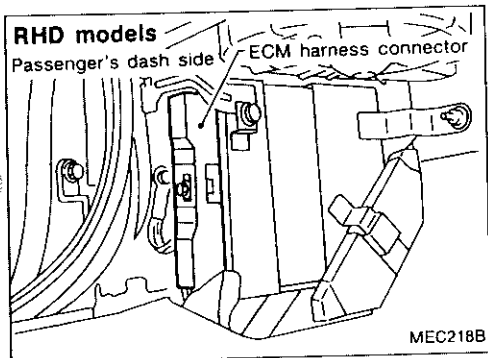
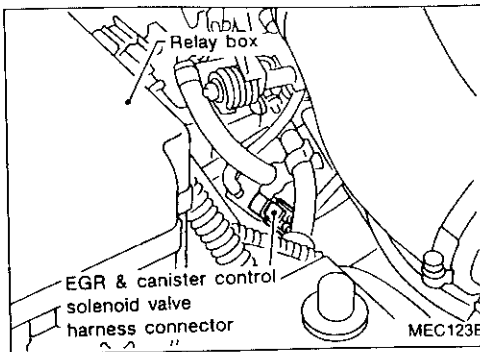
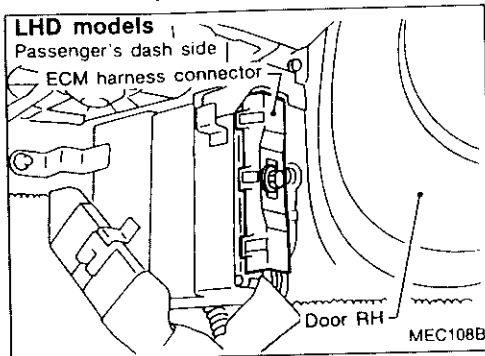

INSPECTION START

**A**

**CHECK OVERALL FUNCTION.**

- 1) Start engine and warm it up sufficiently.
- 2) Perform diagnostic test mode II (Self-diagnostic results).  
Make sure that diagnostic trouble code No. 12 is not displayed.
- 3) Make sure that EGR valve spring moves up and down (Use your finger) under the following conditions.  
**At idle:**  
Spring does not move.  
**Racing engine from idle to 3,000 rpm:**  
Spring moves up and down.

OK → INSPECTION END

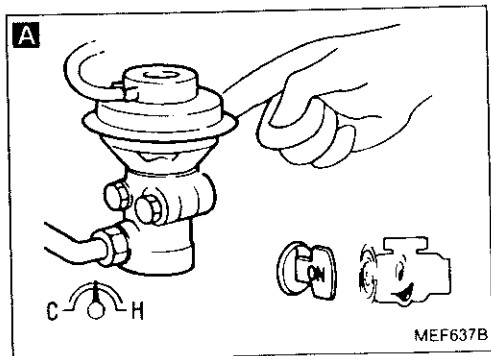

**B**

**CHECK VACUUM SOURCE TO EGR VALVE.**

- 1) Disconnect vacuum hoses to EGR valve and activated carbon canister.
- 2) Make sure that vacuum exists under the following conditions.  
**At idle:**  
Vacuum should not exist.  
**Racing engine from idle to 3,000 rpm:**  
Vacuum should exist.

OK → CHECK COMPONENTS (EGR valve, EGRC-BPT valve and activated carbon canister).  
Refer to "Electrical Components Inspection".  
(See pages EC-203, 210.)

Replace malfunctioning component(s).

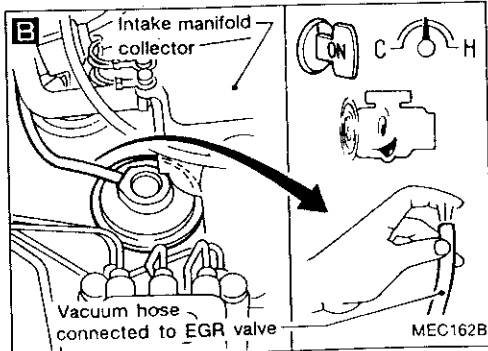

NG → (A)

GI  
VA  
EM  
LC  
**EC**  
FE  
CL  
MT  
AT  
PD  
FA  
RA  
RR  
ST  
RS  
BT  
HA  
EL  
DX

# TROUBLE DIAGNOSES

## Diagnostic Procedure 33 (Cont'd)

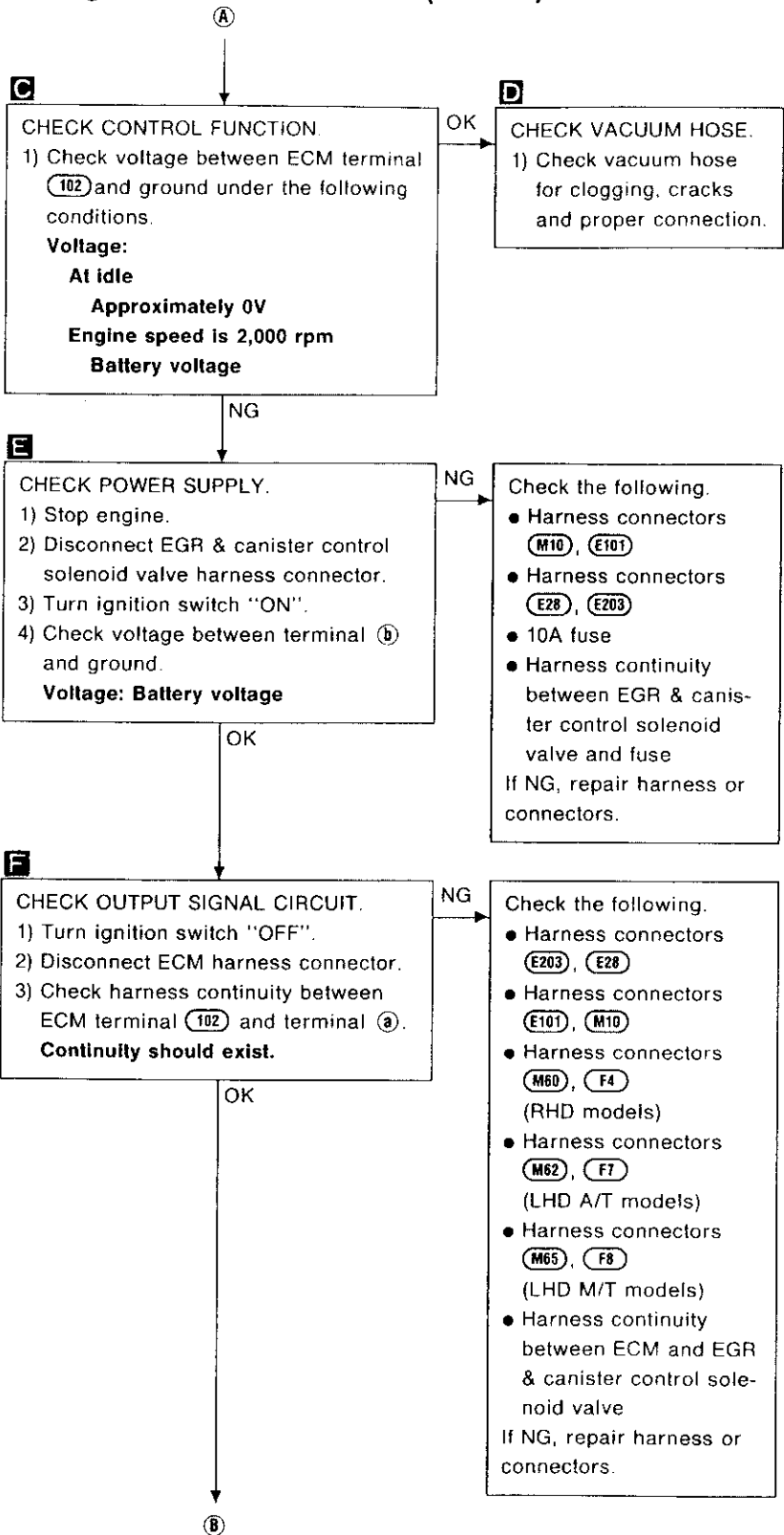
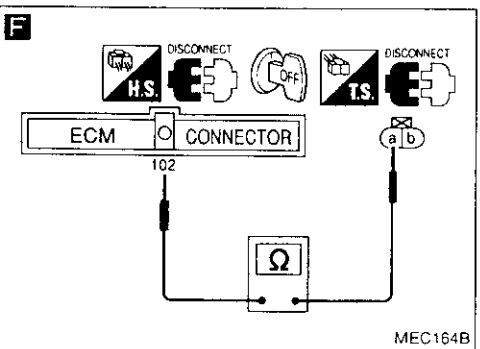
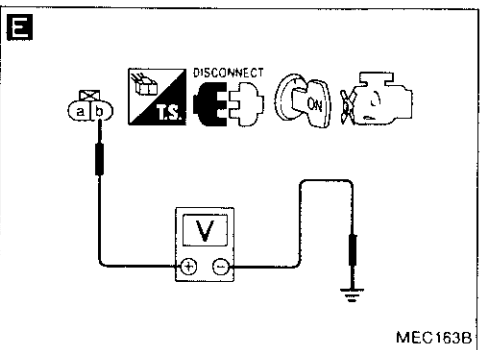
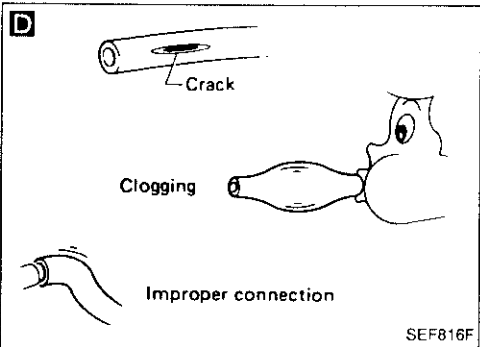
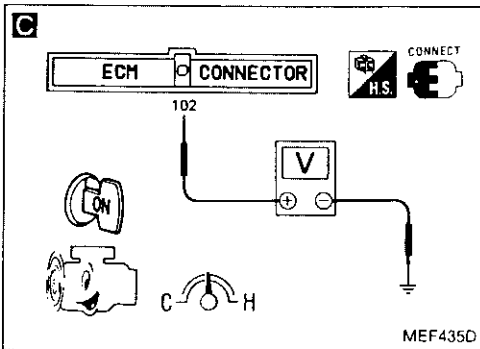
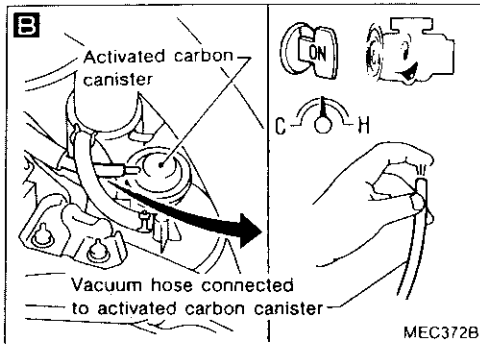

# TROUBLE DIAGNOSES

## Diagnostic Procedure 33 (Cont'd)

**G**

■ EGR CONT S/V CIRCUIT ■

DOES THE SOLENOID VALVE MAKE AN OPERATING SOUND EVERY 3 SECONDS?

NEXT NO YES

MEF569B

**G**

■ ACTIVE TEST ■

EGR CONT SOL/V OFF

=== MONITOR ===

CAS-RPM (REF) 0rpm

ON ON/OFF OFF

SEF222N

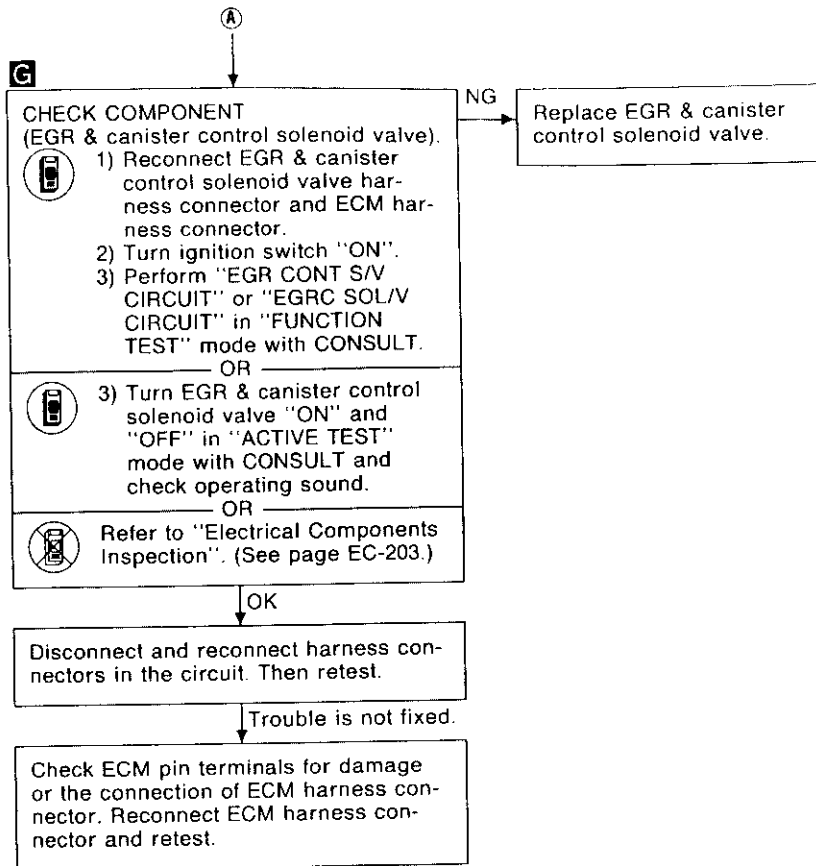

GI

VA

EM

LC

**EC**

FE

CL

MT

AT

PD

FA

RA

BR

ST

RS

BT

HA

EL

DX

# TROUBLE DIAGNOSES

## Diagnostic Procedure 34

HEATED OXYGEN SENSOR (Not self-diagnostic item)

EC-H02S-01

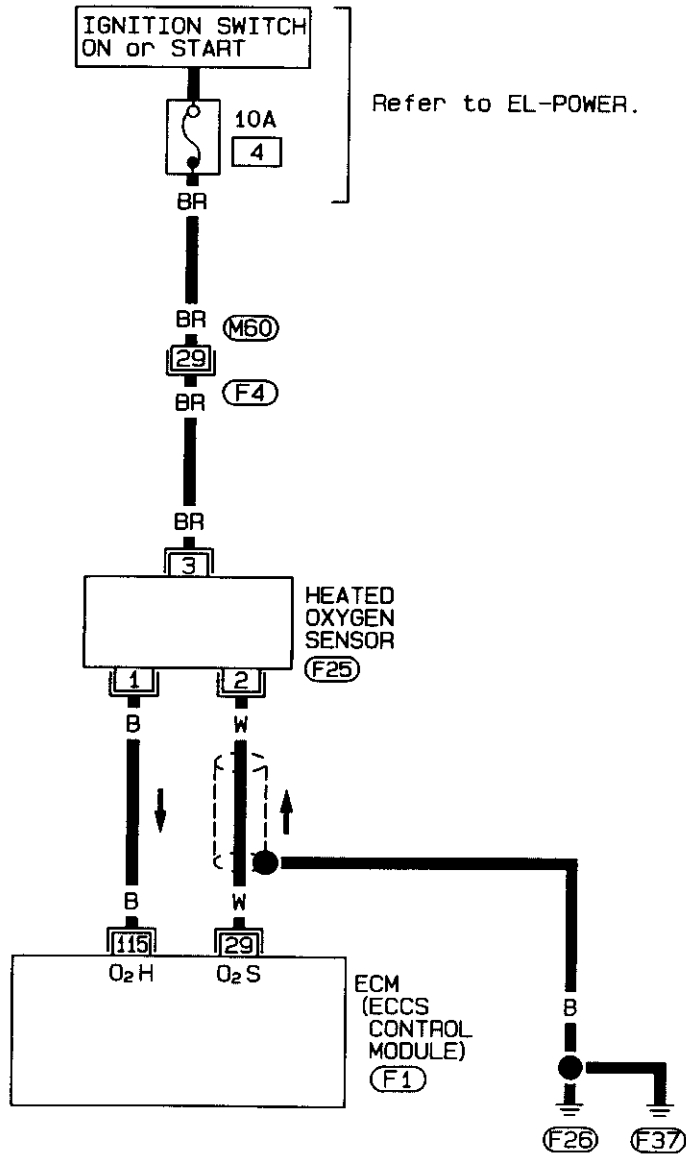

Refer to last page (Foldout page).

M60, F4

101	102	103	104	105	106	107	108	1	2	3	4	5	6	7	8	9	10	21	22	23	24	25	26	27	28	29	30	41	42	43	44	45	46	47	48	49	50
109	110	111	112	113	114	115	116	11	12	13	14	15	16	17	18	19	20	31	32	33	34	35	36	37	38	39	40	51	52	53	54	55	56	57	58	59	60

F1  
L



SEF833P



# TROUBLE DIAGNOSES

## Diagnostic Procedure 34 (Cont'd)

### Harness layout

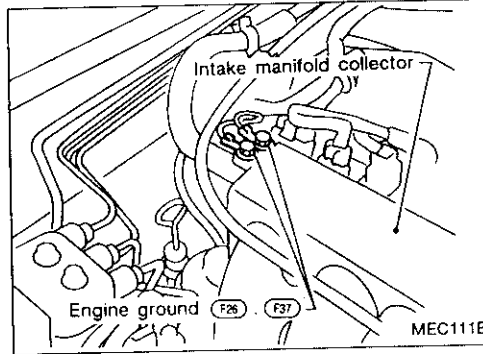
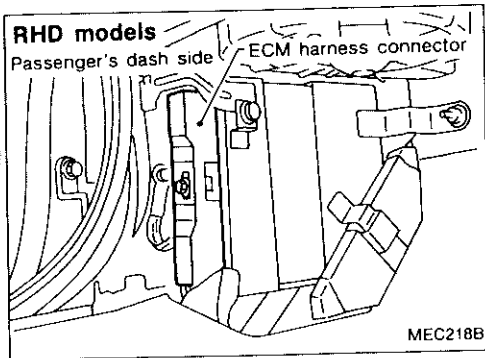
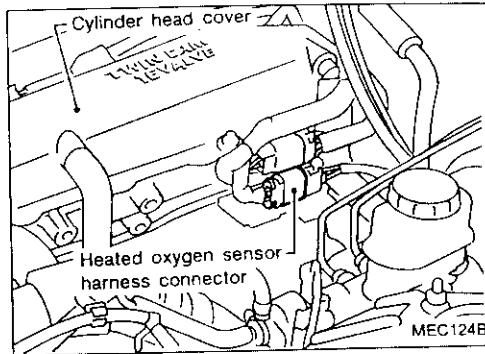
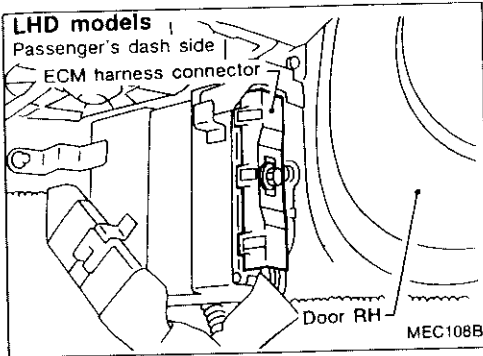

GI

MA

EM

LC

**EC**

FE

CL

MT

AT

PD

FA

RA

BR

ST

RS

BT

RA

EL

DX

# TROUBLE DIAGNOSES

## Diagnostic Procedure 34 (Cont'd)

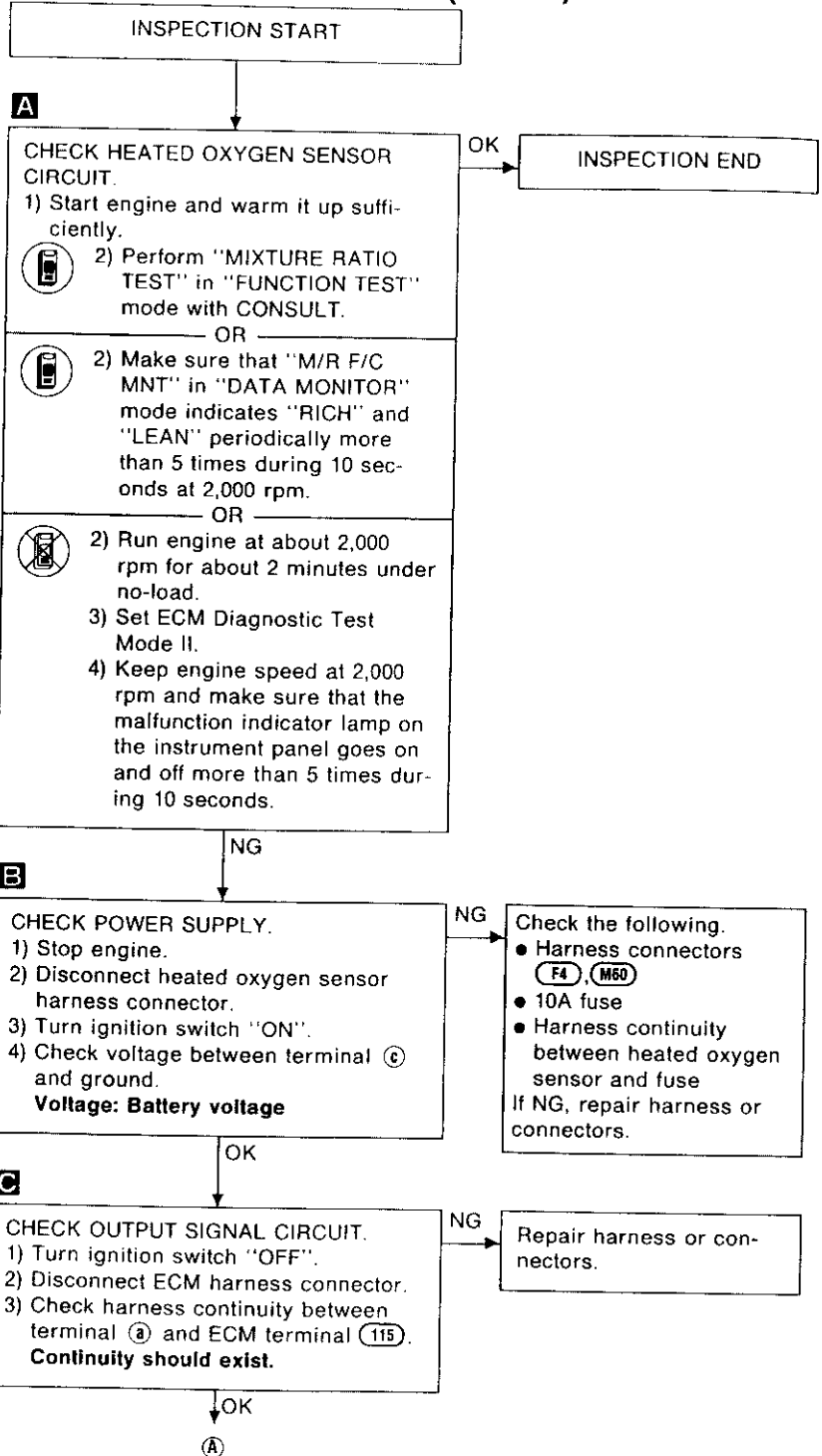
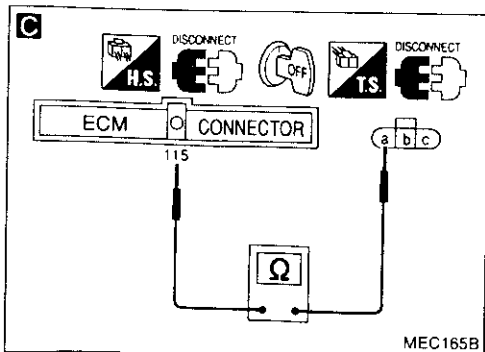
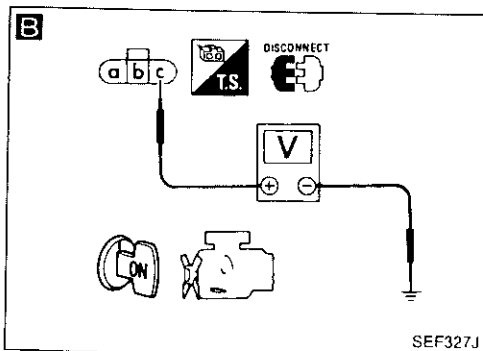
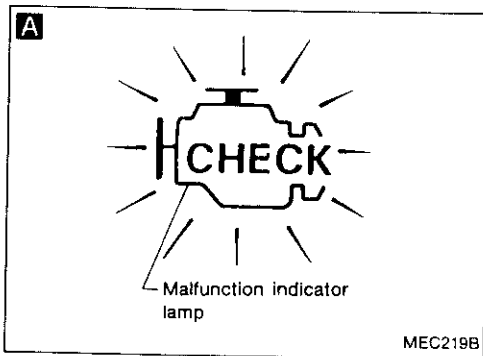
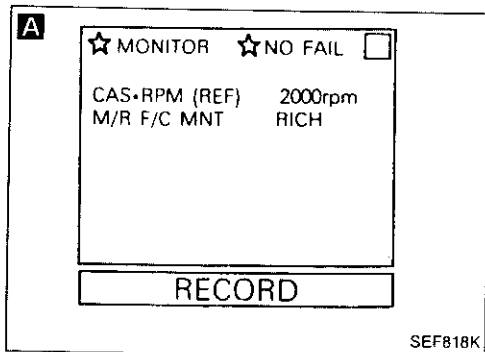
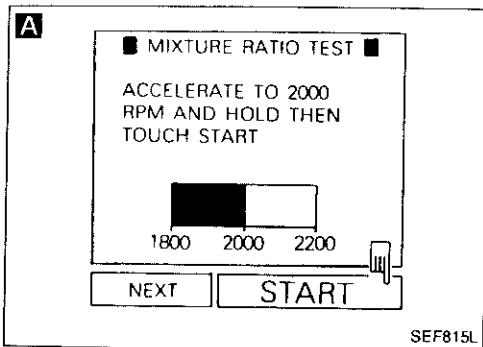

# TROUBLE DIAGNOSES

## Diagnostic Procedure 34 (Cont'd)

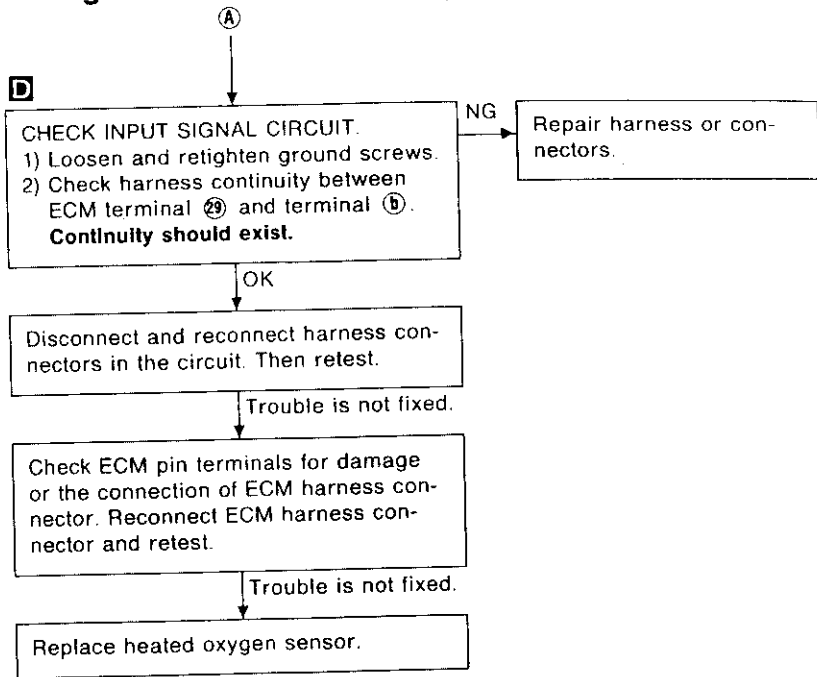
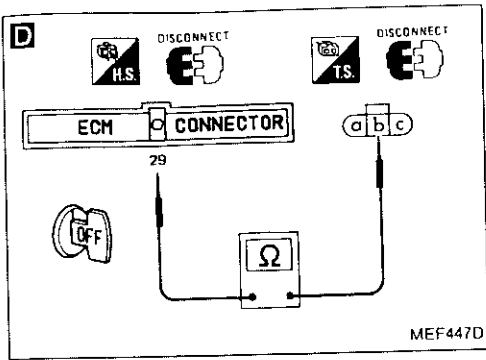

CI  
 MA  
 EM  
 LC  
**EC**  
 FE  
 CL  
 MT  
 AT  
 PD  
 FA  
 RA  
 BR  
 ST  
 RS  
 RT  
 HA  
 EL  
 IDX

# TROUBLE DIAGNOSES

## Diagnostic Procedure 35

### INJECTOR CIRCUIT (Not self-diagnostic item)

EC-INJECT-01

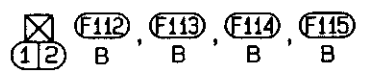
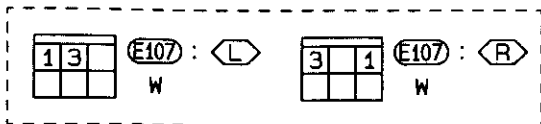
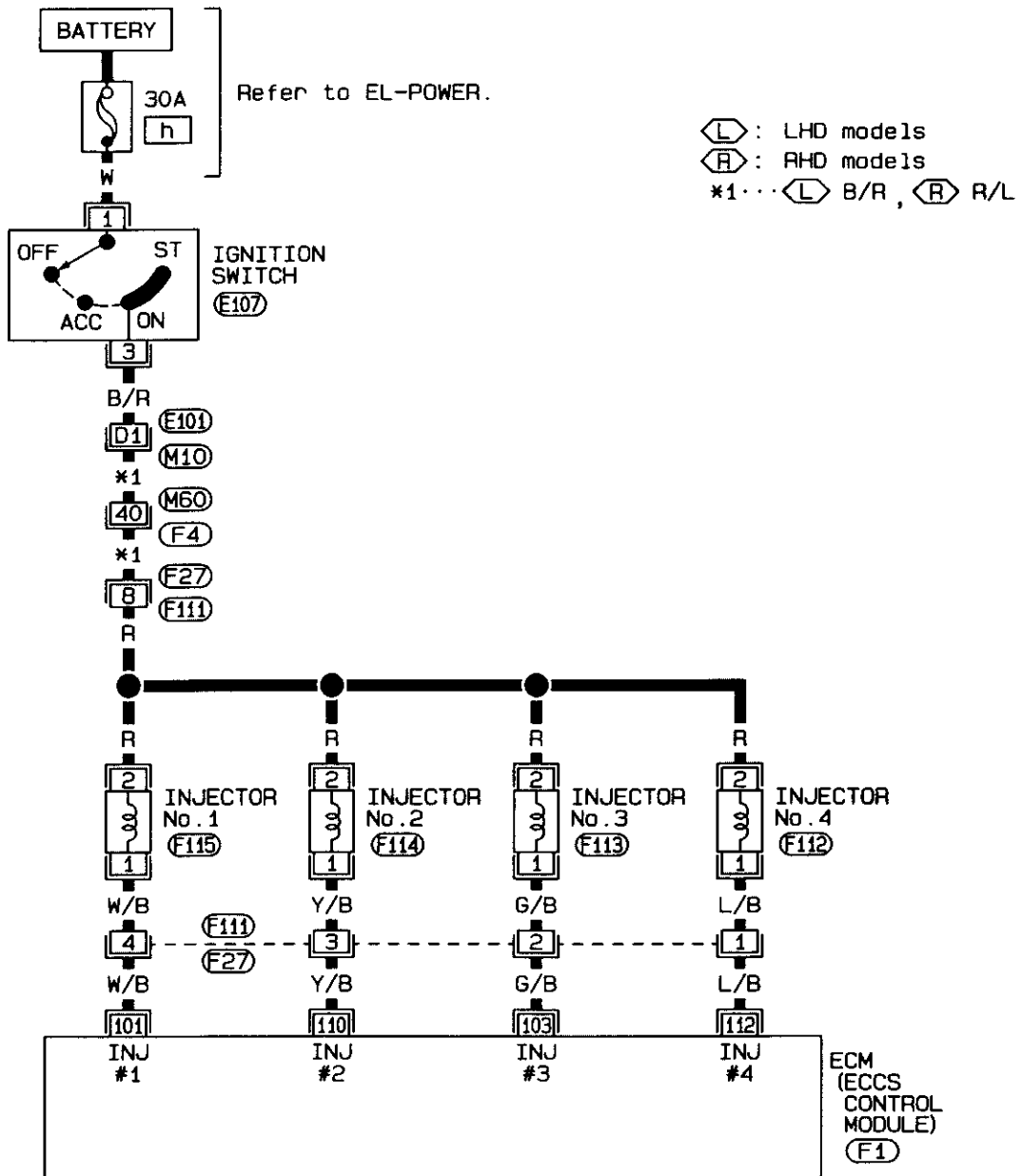

Refer to last page (Foldout page).

M10, E101  
M60, F4

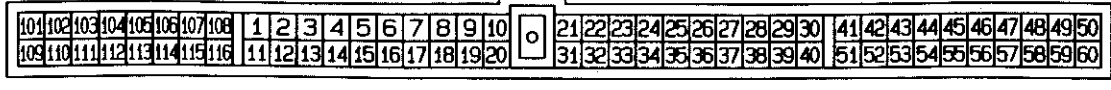
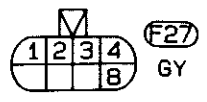

SEF834P

# TROUBLE DIAGNOSES

## Diagnostic Procedure 35 (Cont'd)

### Harness layout

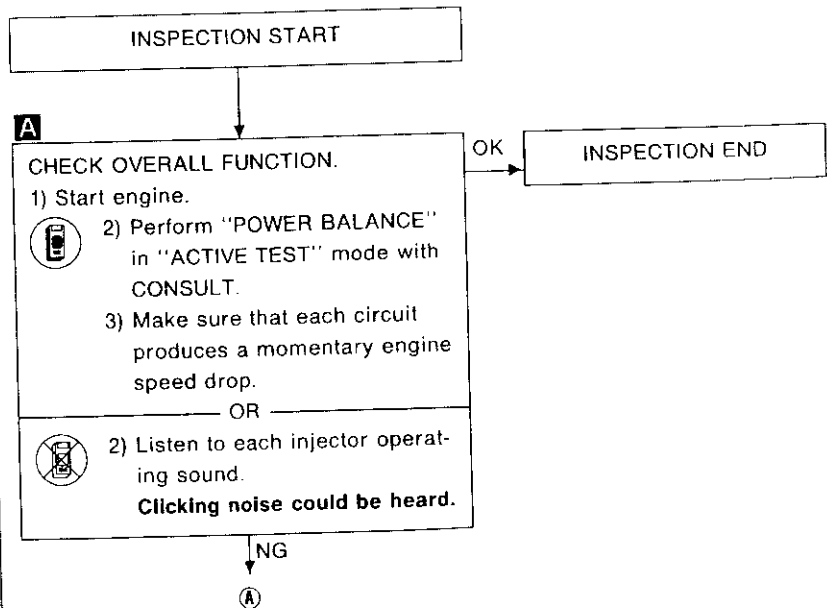
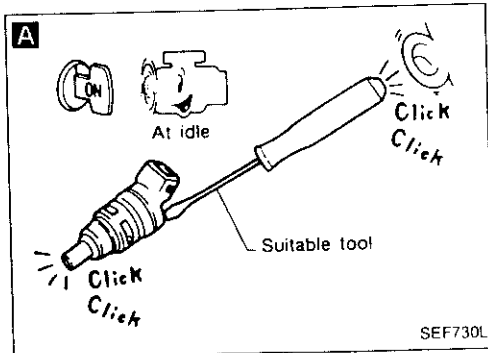
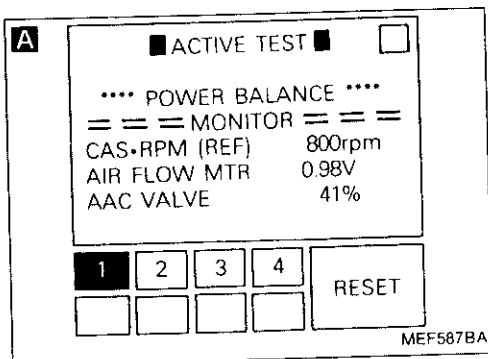
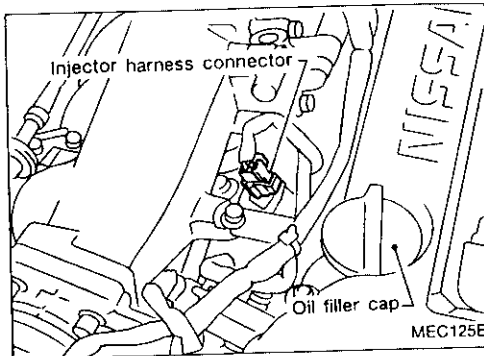
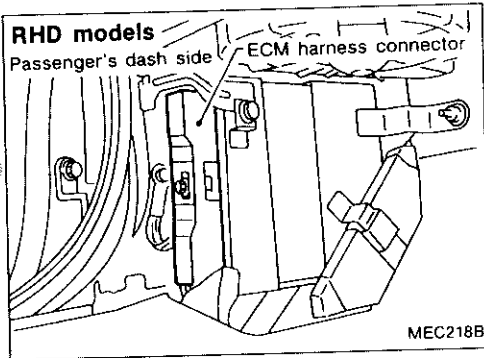
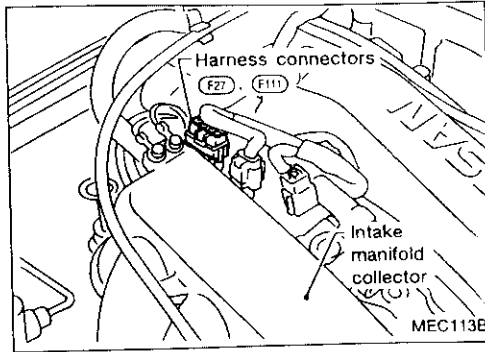
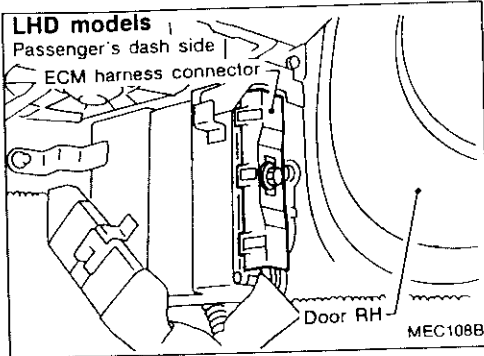

GI  
VA  
EM  
LC  
**EC**  
FE  
CL  
MT  
AT  
PD  
FA  
RA  
BR  
ST  
RS  
BT  
HA  
EL  
FDX

# TROUBLE DIAGNOSES

## Diagnostic Procedure 35 (Cont'd)

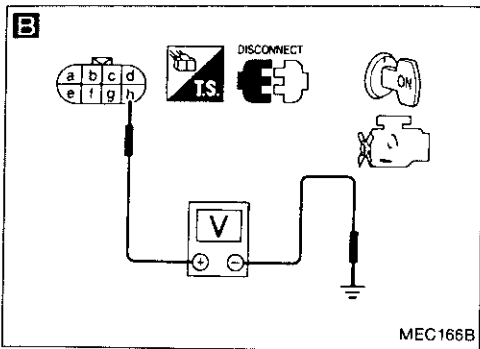

**B**

**CHECK POWER SUPPLY.**

- 1) Stop engine.
- 2) Disconnect harness connectors (F27), (F111).
- 3) Turn ignition switch "ON".
- 4) Check voltage between terminal (h) and ground.

**Voltage: Battery voltage**

NG → Check the following.

- Harness connectors (F27), (F111)
- Harness connectors (F4), (M60)
- Harness connectors (M10), (E101)
- Harness continuity between ignition switch and harness connector (F27)

If NG, repair harness or connectors.

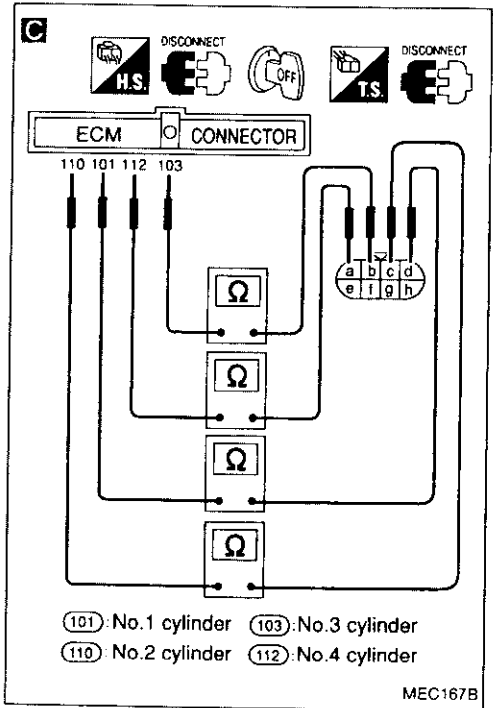

**C**

**CHECK OUTPUT SIGNAL CIRCUIT.**

- 1) Turn ignition switch "OFF".
- 2) Disconnect ECM harness connector.
- 3) Check harness continuity between ECM terminal (101) and terminal (d), ECM terminal (110) and terminal (c), ECM terminal (103) and terminal (b), ECM terminal (112) and terminal (a).

**Continuity should exist.**

NG → Check the following.

- Harness connectors (F27), (F111)
- Harness continuity between ECM and harness connector (F27)

If NG, repair harness or connectors.

**CHECK COMPONENT (Injector).**

Refer to "Electrical Components Inspection". (See page EC-205.)

NG → Replace injector.

OK → Disconnect and reconnect harness connectors in the circuit. Then retest.

Trouble is not fixed. → Check ECM pin terminals for damage or the connection of ECM harness connector. Reconnect ECM harness connector and retest.

# TROUBLE DIAGNOSES

## Diagnostic Procedure 36

FUEL PUMP (Not self-diagnostic item)

EC-F/PUMP-01

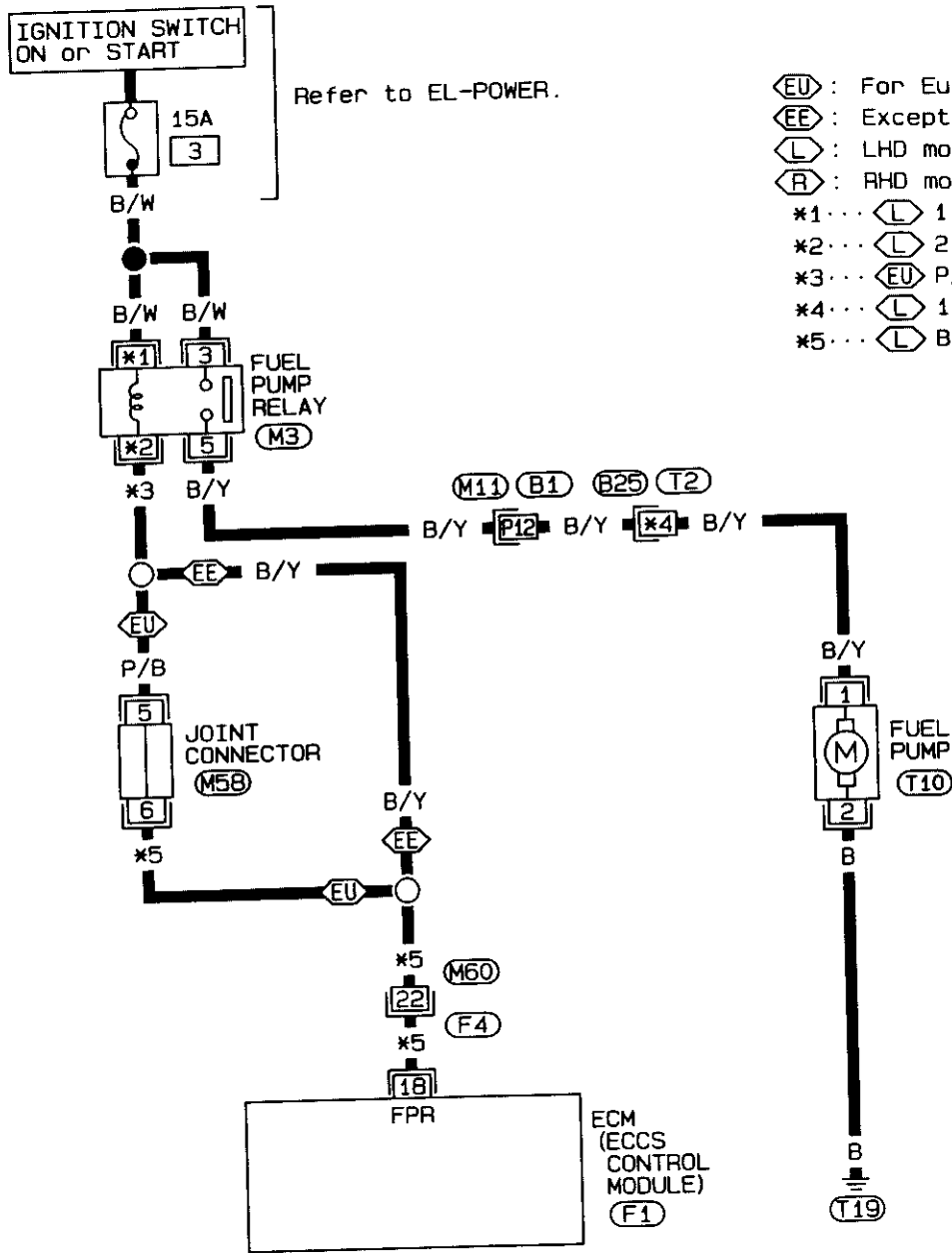

Refer to EL-POWER.

- ◊EU : For Europe
- ◊EE : Except for Europe
- ◊L : LHD models
- ◊R : RHD models
- \*1... ◊L 1, ◊R 2
- \*2... ◊L 2, ◊R 1
- \*3... ◊EU P/B, ◊EE B/Y
- \*4... ◊L 1, ◊R 3
- \*5... ◊L B/P, ◊R B/Y

3  
M  
B  
L  
EC  
FE  
CL  
WT  
AT  
FD  
FA  
BA  
RA  
ST  
RE  
BT

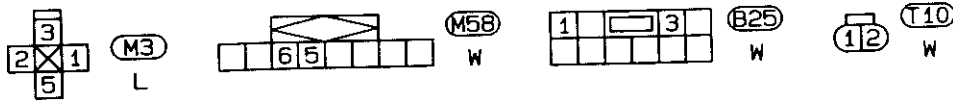

Refer to last page (Foldout page).

- M11, B1
- M60, F4

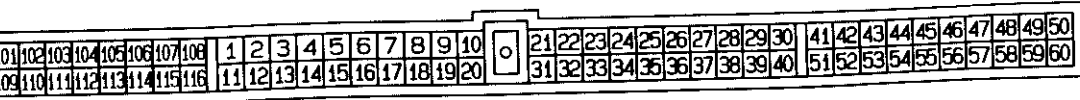

SEF845P

# TROUBLE DIAGNOSES

## Diagnostic Procedure 36 (Cont'd)

### Harness layout

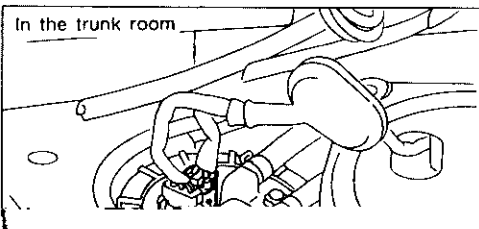
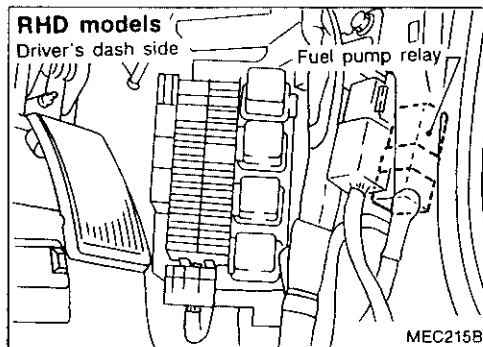
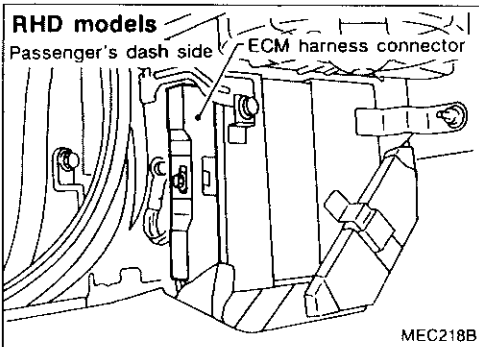
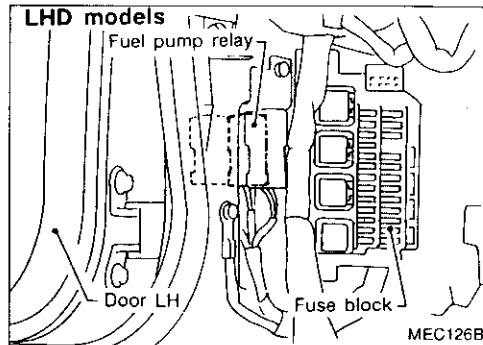
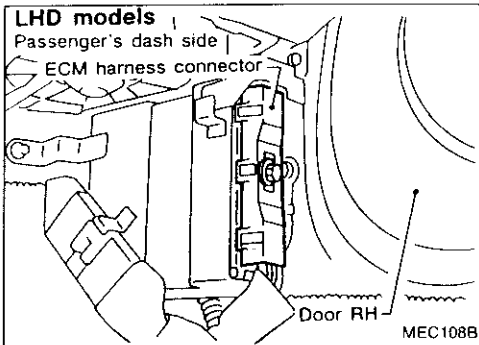



# TROUBLE DIAGNOSES

## Diagnostic Procedure 36 (Cont'd)

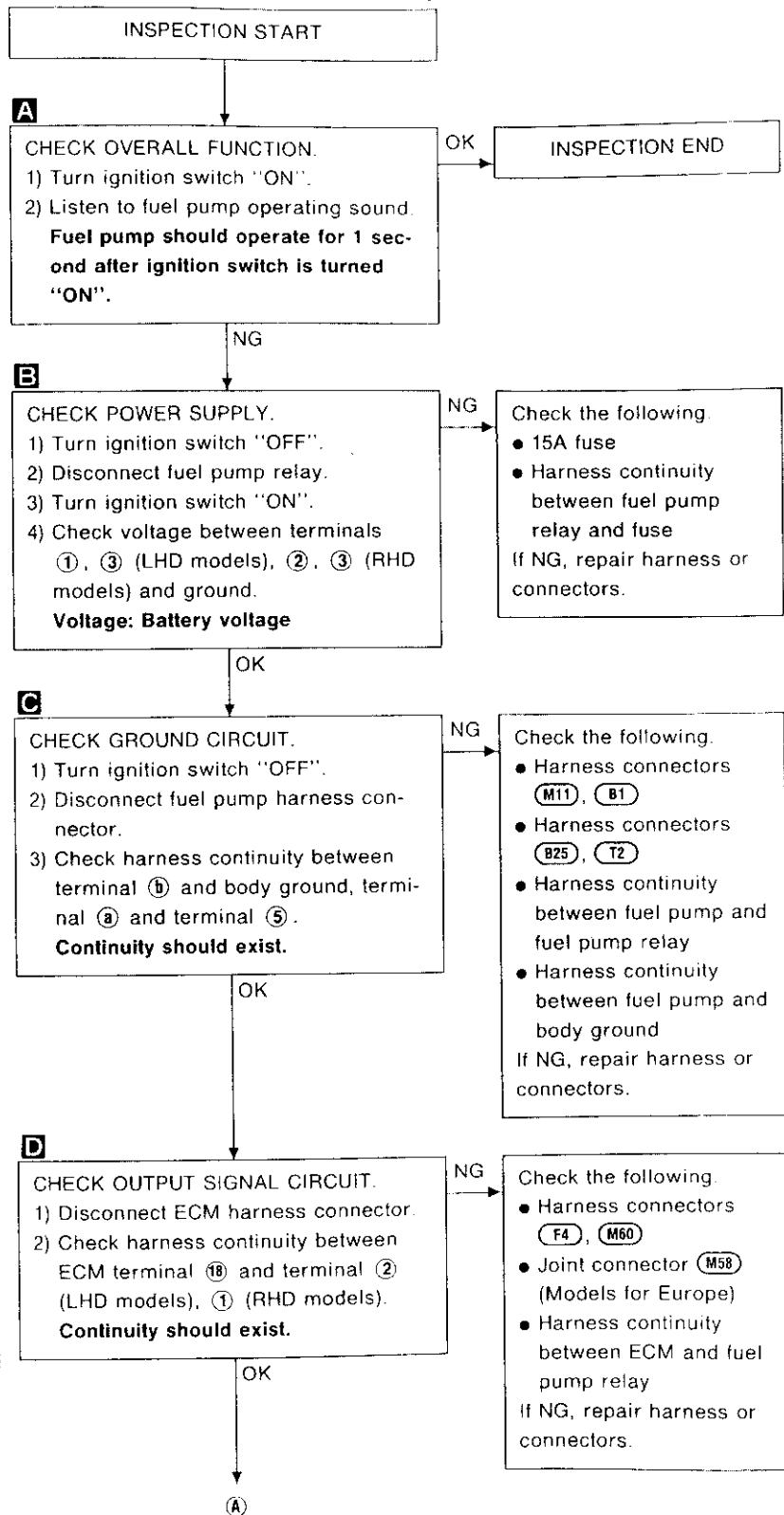
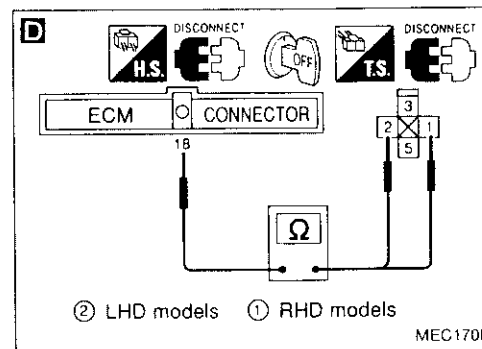
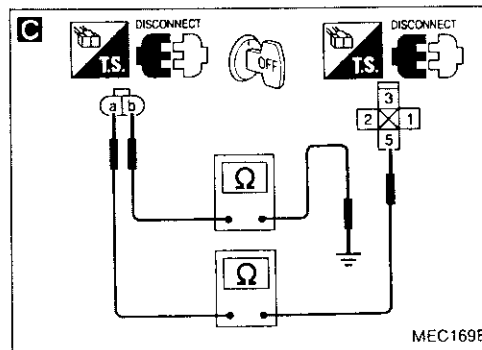
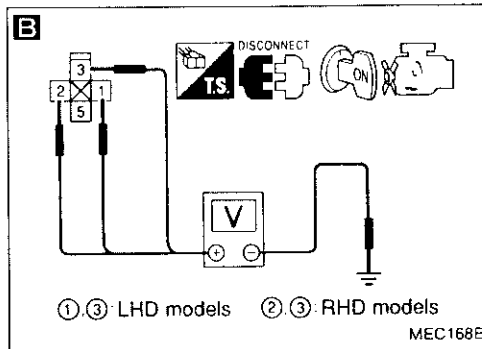
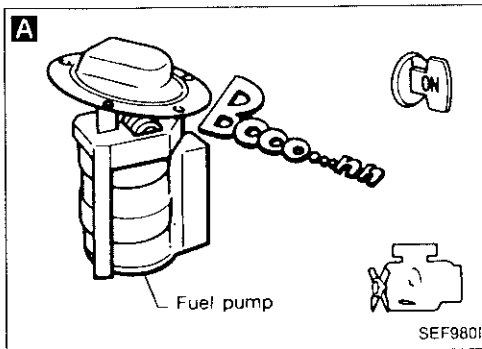

EC  
FE  
CL  
MT  
AT  
PD  
FA  
BA  
BR  
ST  
RS  
BT  
HA  
EL  
DX

# TROUBLE DIAGNOSES

## Diagnostic Procedure 36 (Cont'd)

**E**

■ FUEL PUMP CIRCUIT ■  
 PINCH FUEL FEED HOSE WITH FINGERS. IS THERE ANY PRESSURE PULSATION ON THE FUEL FEED HOSE?  
 OR  
 DOES THE FUEL PUMP RELAY MAKE AN OPERATING SOUND EVERY 3 SECONDS?

NEXT NO YES

SEF194L

**E**

■ ACTIVE TEST ■

FUEL PUMP RELAY ON

== == MONITOR == ==  
 CAS-RPM (REF) 0rpm

ON ON/OFF OFF

SEF498L

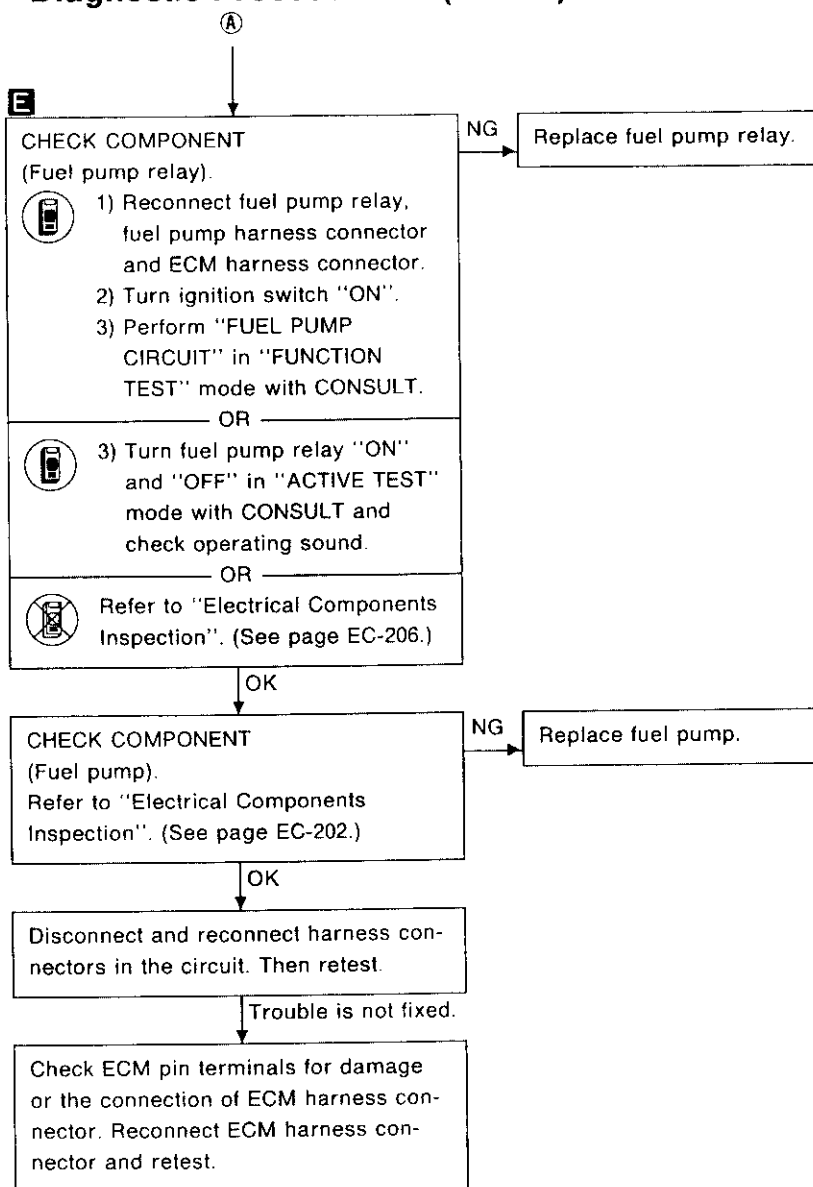

# TROUBLE DIAGNOSES

## Diagnostic Procedure 37

### WASTEGATE VALVE CONTROL (Not self-diagnostic item)

EC-WG/V-01

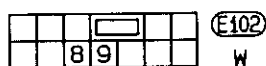
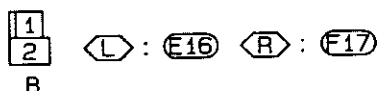
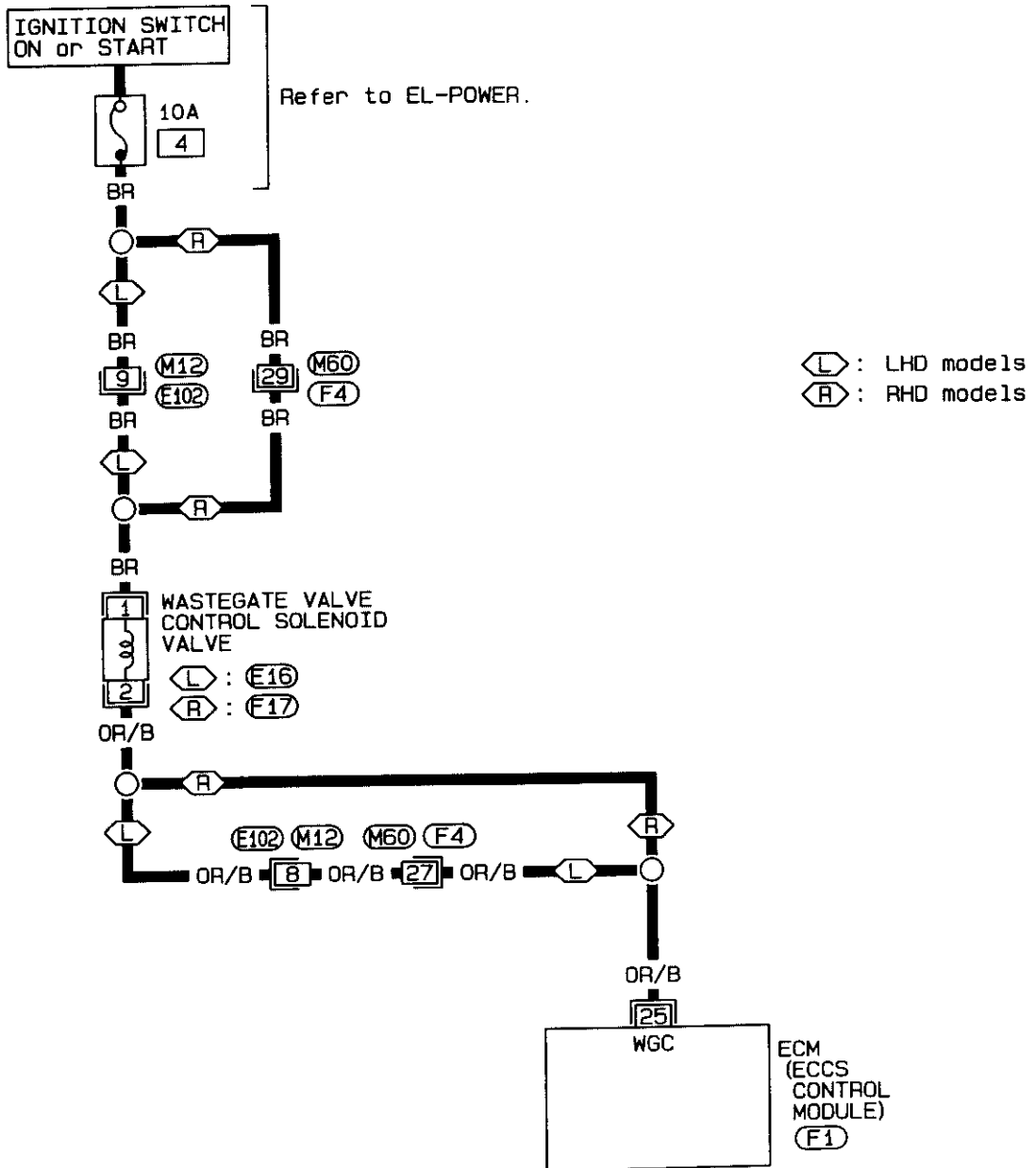

Refer to last page (Foldout page).

M60, F4

101	102	103	104	105	106	107	108	1	2	3	4	5	6	7	8	9	10	11	12	13	14	15	16	17	18	19	20	21	22	23	24	25	26	27	28	29	30	31	32	33	34	35	36	37	38	39	40	41	42	43	44	45	46	47	48	49	50	51	52	53	54	55	56	57	58	59	60
-----	-----	-----	-----	-----	-----	-----	-----	---	---	---	---	---	---	---	---	---	----	----	----	----	----	----	----	----	----	----	----	----	----	----	----	----	----	----	----	----	----	----	----	----	----	----	----	----	----	----	----	----	----	----	----	----	----	----	----	----	----	----	----	----	----	----	----	----	----	----	----

F1  
L



SF841P

## TROUBLE DIAGNOSES

### Diagnostic Procedure 37 (Cont'd)

#### Harness layout

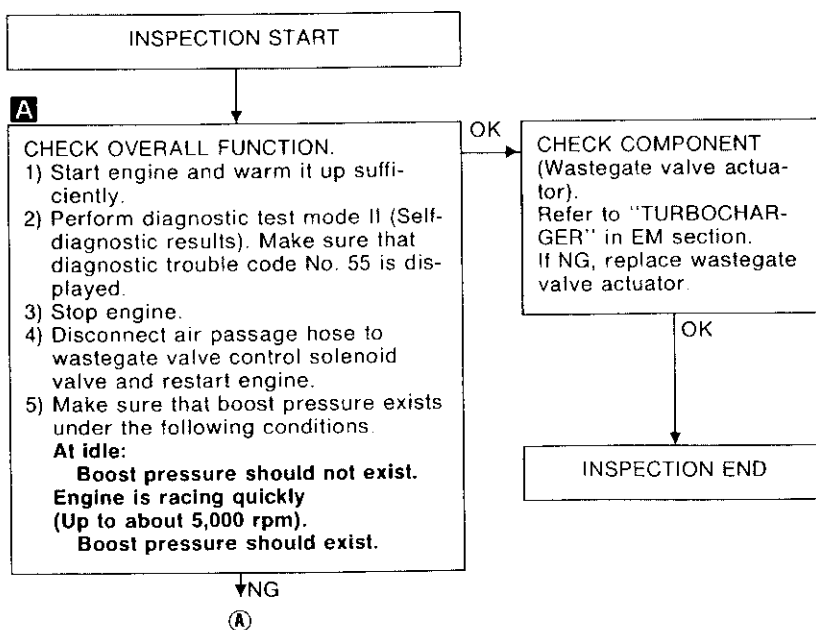
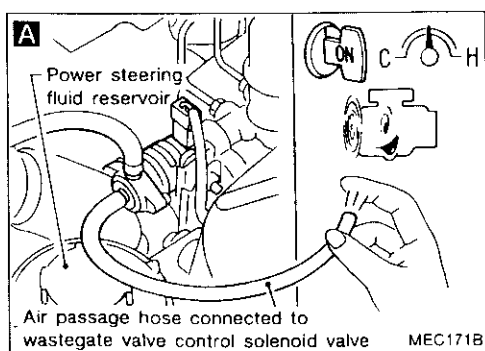
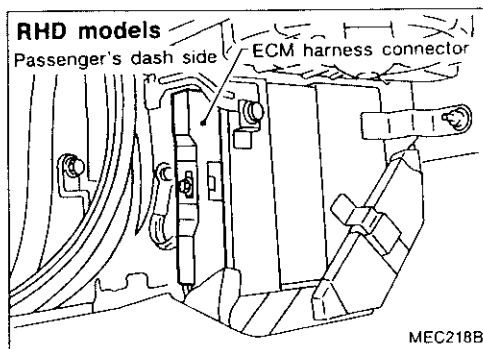
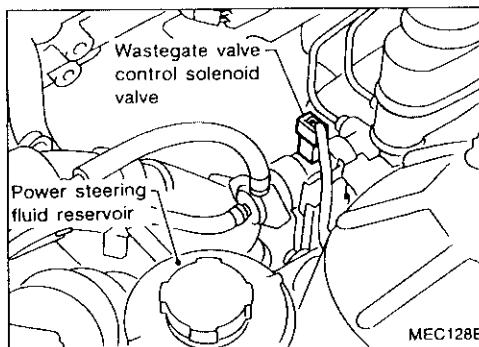
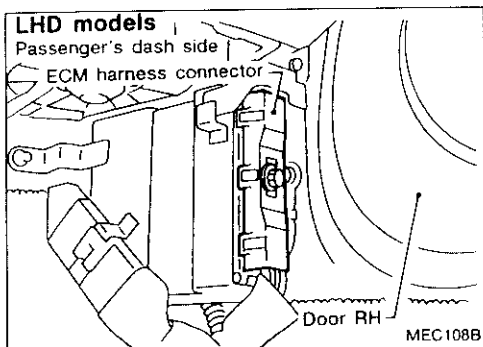

# TROUBLE DIAGNOSES

## Diagnostic Procedure 37 (Cont'd)

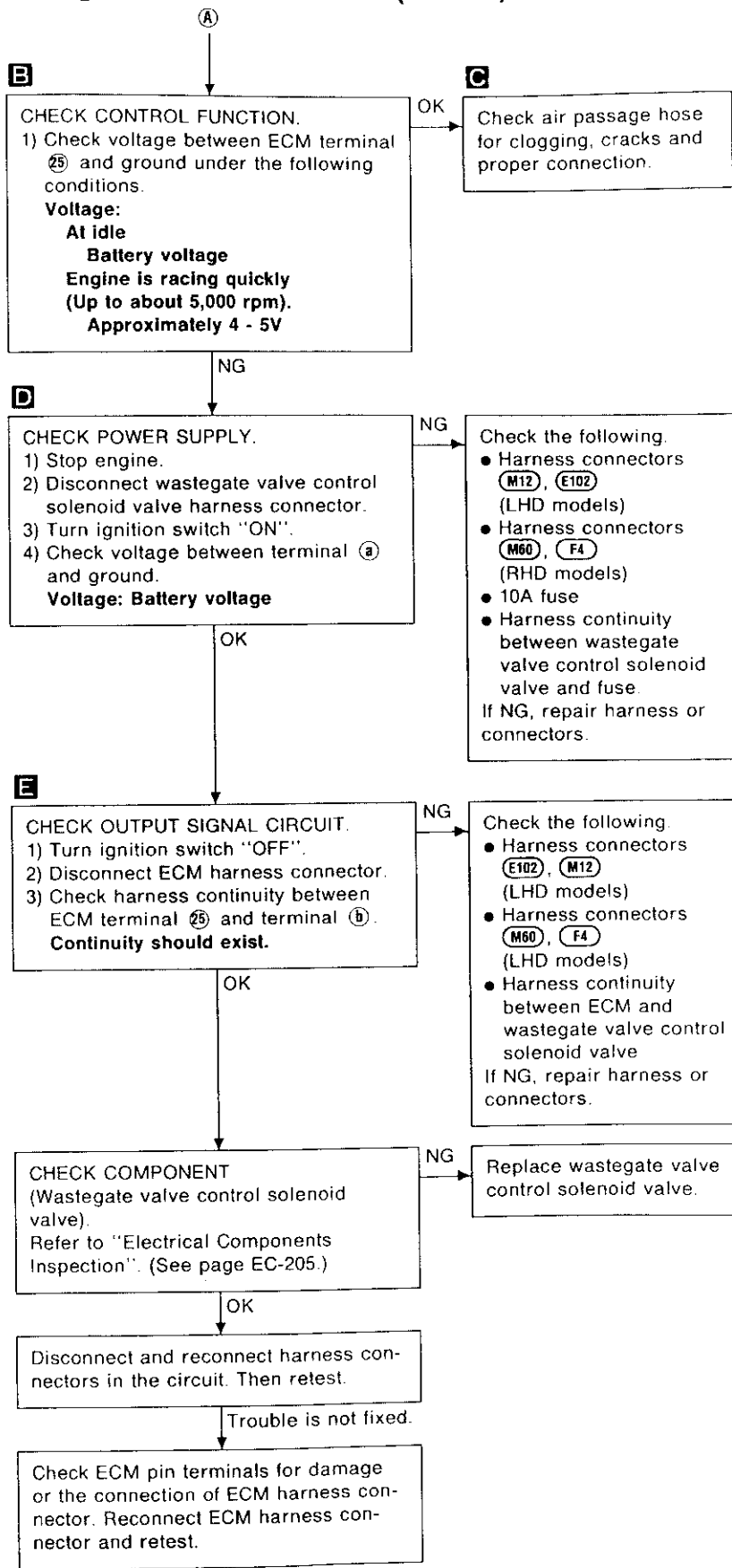
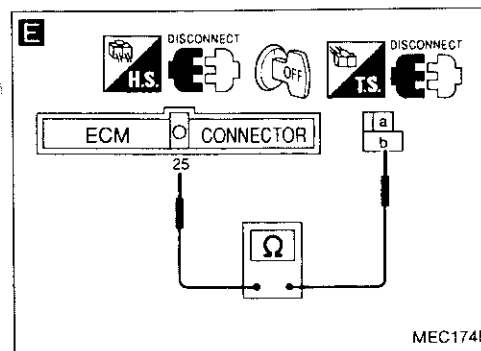
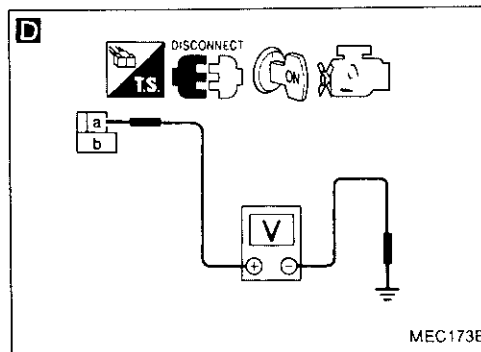
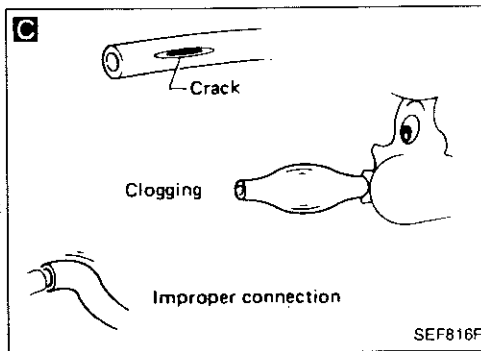
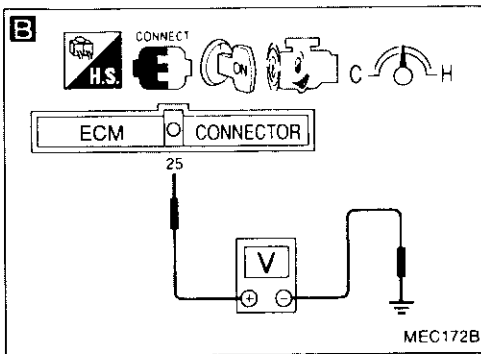

BT  
VA  
EM  
LG  
EC  
FE  
CL  
WT  
AT  
PD  
FA  
BA  
BR  
ST  
BS  
ST  
HA  
ET  
DX

# TROUBLE DIAGNOSES

## Diagnostic Procedure 38

VALVE TIMING CONTROL (Not self-diagnostic item)

EC-VTC-01

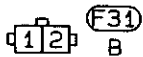
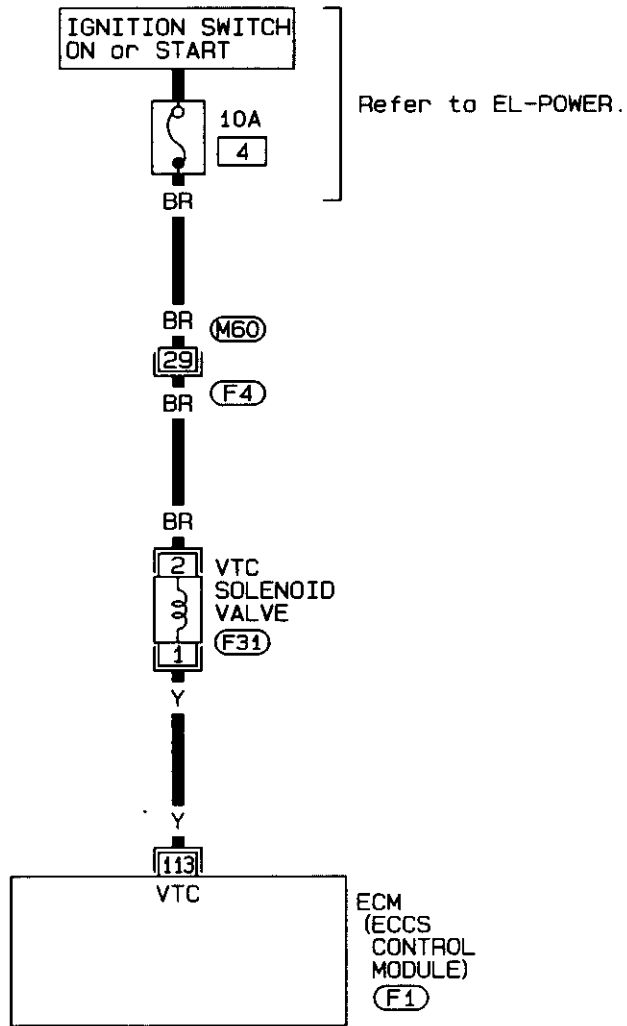

Refer to last page  
(Foldout page).

(M60), (F4)

101	102	103	104	105	106	107	108	1	2	3	4	5	6	7	8	9	10	21	22	23	24	25	26	27	28	29	30	41	42	43	44	45	46	47	48	49	50
109	110	111	112	113	114	115	116	11	12	13	14	15	16	17	18	19	20	31	32	33	34	35	36	37	38	39	40	51	52	53	54	55	56	57	58	59	60

(F1)  
L



SEF842P

# TROUBLE DIAGNOSES

## Diagnostic Procedure 38 (Cont'd)

### Harness layout

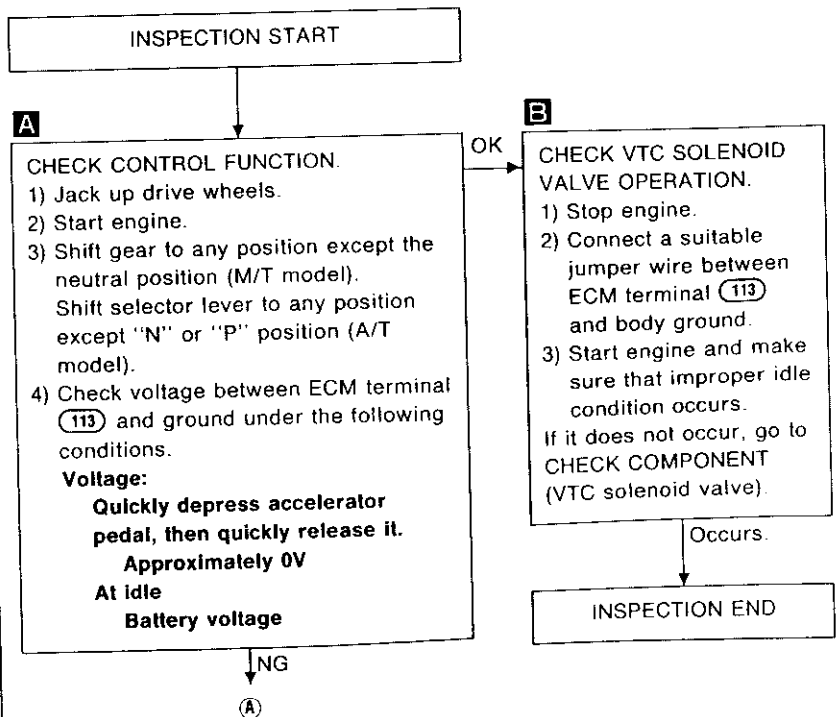
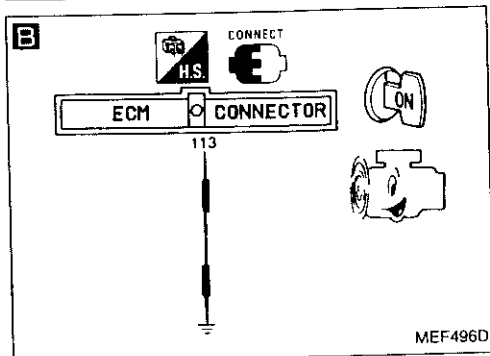
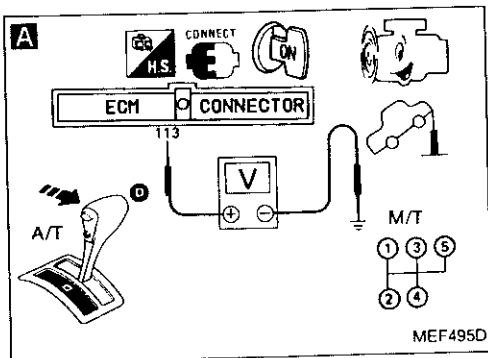
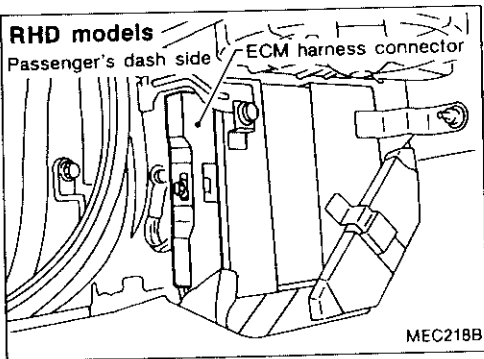
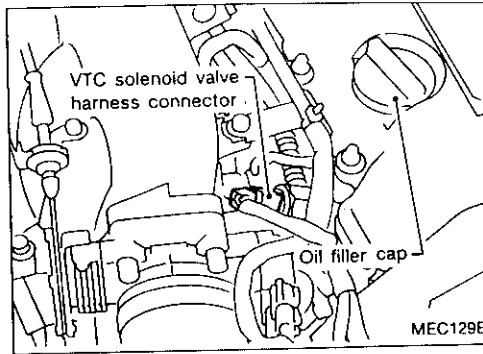
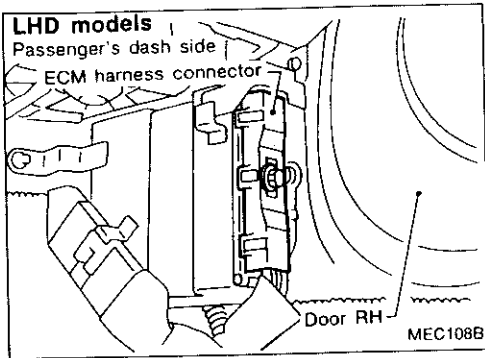

GI  
MA  
EM  
LC  
EC  
FE  
CL  
MT  
AT  
PD  
FA  
RA  
BR  
ST  
RS  
BT  
HA  
EL  
DX

# TROUBLE DIAGNOSES

## Diagnostic Procedure 38 (Cont'd)

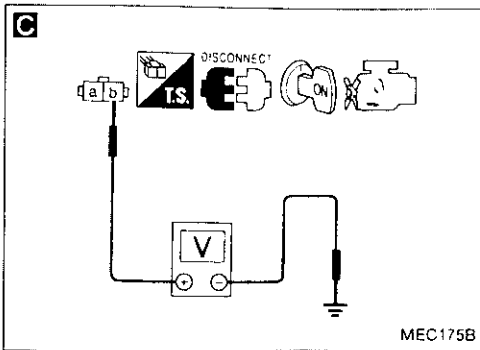

**C**

**CHECK POWER SUPPLY.**

- 1) Stop engine.
- 2) Disconnect VTC solenoid valve harness connector.
- 3) Turn ignition switch "ON".
- 4) Check voltage between terminal **(b)** and ground.

**Voltage: Battery voltage.**

NG → Check the following.

- Harness connectors
- 10A fuse
- 10A fuse
- Harness continuity between VTC solenoid valve and fuse

If NG, repair harness or connectors.

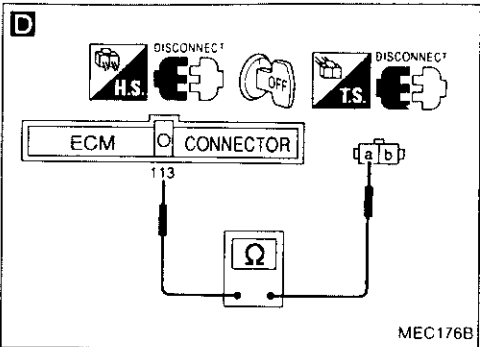

**D**

**CHECK INPUT SIGNAL CIRCUIT.**

- 1) Turn ignition switch "OFF".
- 2) Disconnect ECM harness connector.
- 3) Check harness continuity between terminal **(a)** and ECM terminal **(113)**.

**Continuity should exist.**

NG → Repair harness or connectors.

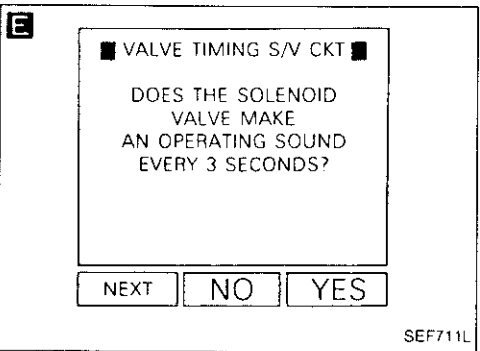

**E**

**CHECK COMPONENT (VTC solenoid valve).**

- 1) Reconnect ECM harness connector and VTC solenoid valve harness connector.
- 2) Turn ignition switch "ON".
- 3) Perform "VALVE TIMING S/V CKT" in "FUNCTION TEST" mode with CONSULT.

OR

- 3) Perform "VALVE TIMING SOL" in "ACTIVE TEST" mode with CONSULT.
- 4) Turn VTC solenoid valve "ON" and "OFF", and check operating sound.

OR

Refer to "Electrical Components Inspection". (See page EC-205.)

NG → Replace VTC solenoid valve.

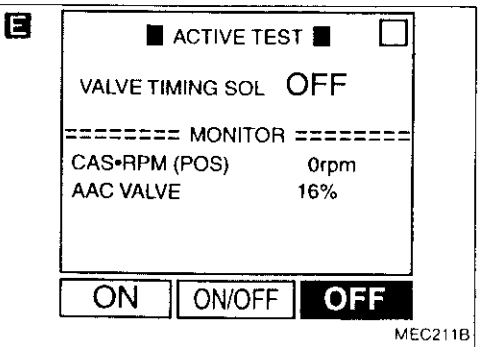

OK → Disconnect and reconnect harness connectors in the circuit. Then retest.

Trouble is not fixed → Check ECM pin terminals for damage or the connection of ECM harness connector. Reconnect ECM harness connector and retest.



# TROUBLE DIAGNOSES

## Diagnostic Procedure 39

IACV-AAC VALVE (Not self-diagnostic item)

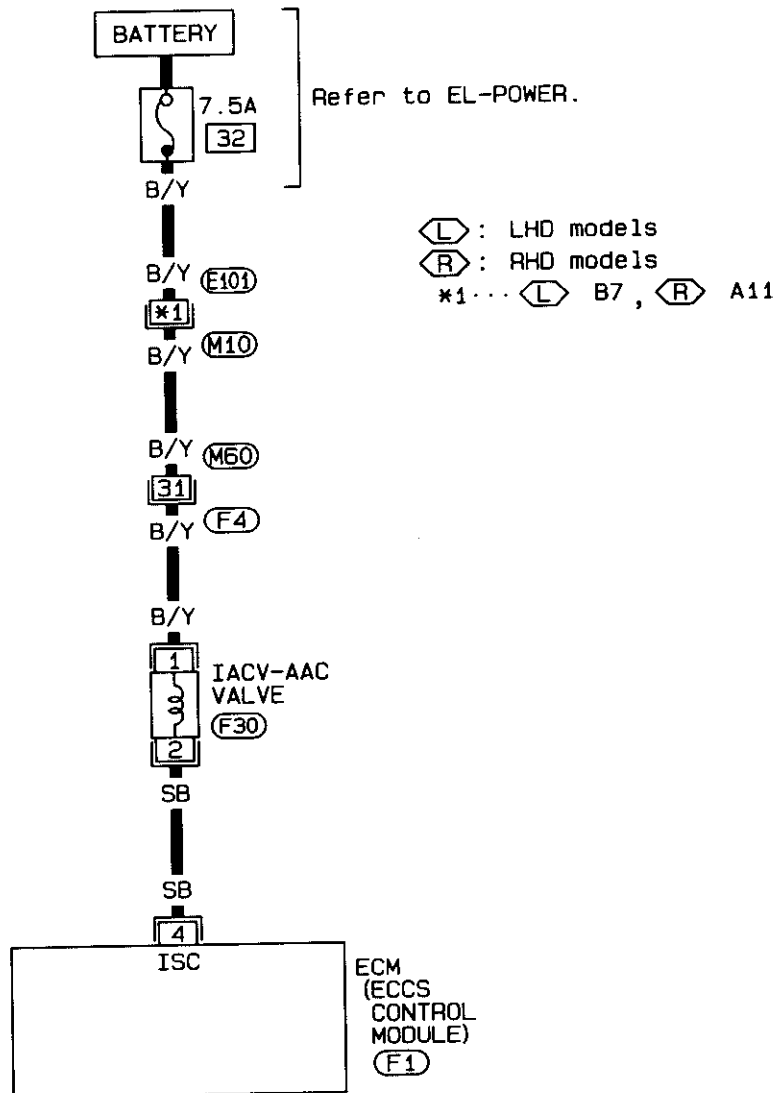

# TROUBLE DIAGNOSES

## Diagnostic Procedure 39 (Cont'd)

### Harness layout

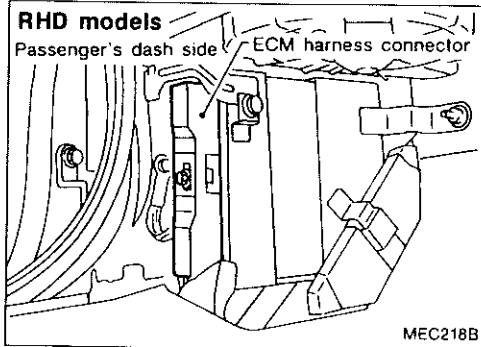
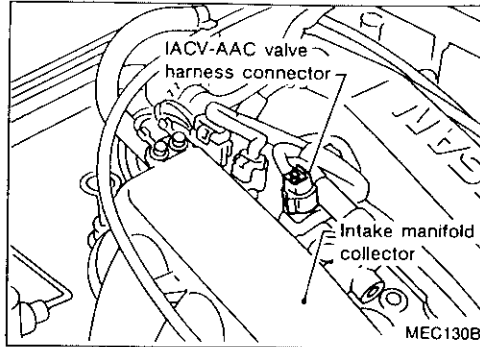
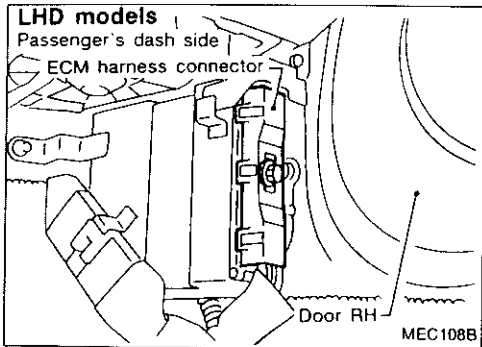

**A**

■ IGN TIMING ADJ ■ □

-- CONDITION SETTING --

IGN/T FEEDBACK HOLD

=== MONITOR ===

CAS-RPM (REF)	800rpm
IGN TIMING	15BTDC
IDLE POSITION	ON

SEF786KA

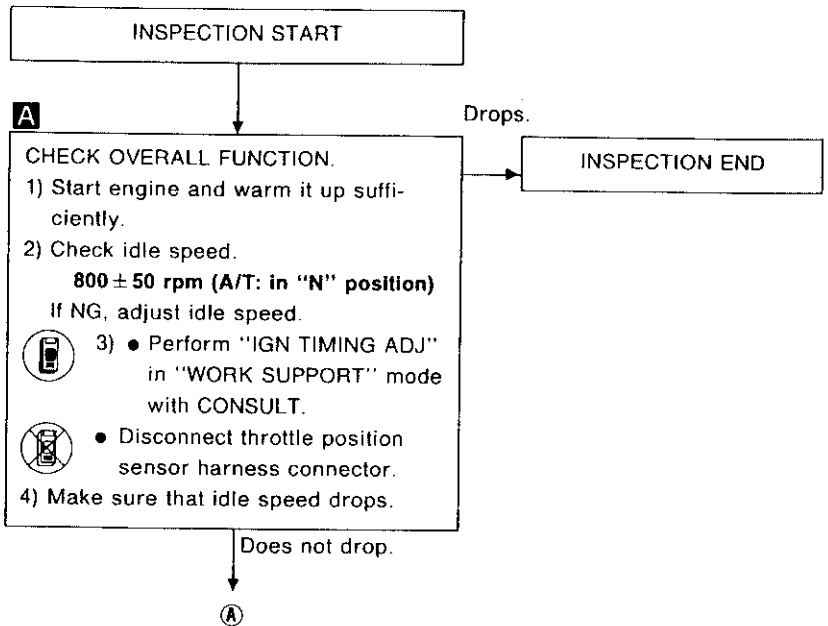
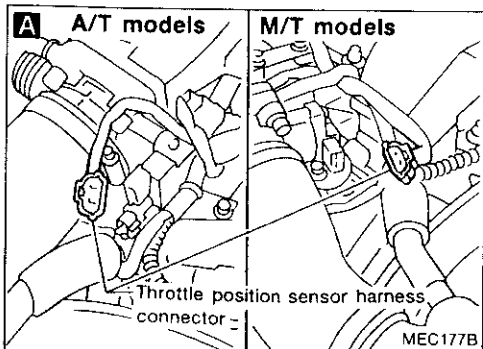

# TROUBLE DIAGNOSES

## Diagnostic Procedure 39 (Cont'd)

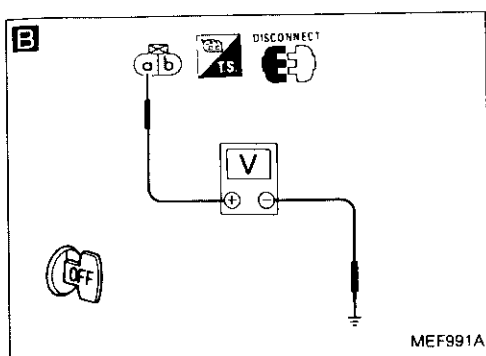

**B**

**CHECK POWER SUPPLY.**

- 1) Stop engine.
- 2) Disconnect IACV-AAC valve harness connector.
- 3) Check voltage between terminal **a** and ground.

**Voltage: Battery voltage**

NG → Check the following.

- Harness connectors **E101**, **M10**
- Harness connectors **M60**, **F4**
- 7.5A fuse
- Harness continuity between IACV-AAC valve and fuse

If NG, repair harness or connectors.

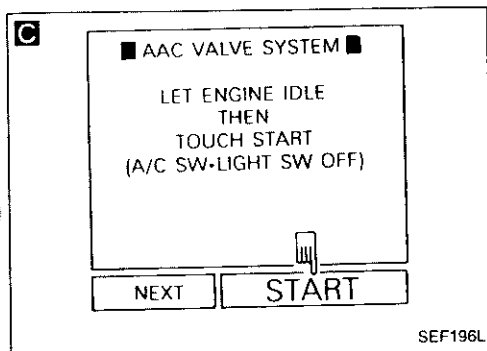

**C**

**CHECK OUTPUT SIGNAL CIRCUIT.**

- 1) Reconnect IACV-AAC valve harness connector.
- 2) Perform "AAC VALVE SYSTEM" or "IACV-AAC/V SYSTEM" in "FUNCTION TEST" mode with CONSULT.

NG → Repair harness or connectors.

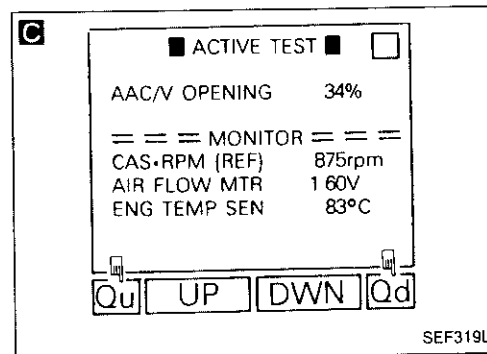

OR

- 2) Perform "AAC VALVE OPENING TEST" or "IACV-AAC/V OPENING" in "ACTIVE TEST" mode with CONSULT.

OR

- 1) Disconnect ECM harness connector.
- 2) Check harness continuity between ECM terminal **a** and terminal **b**.

**Continuity should exist.**

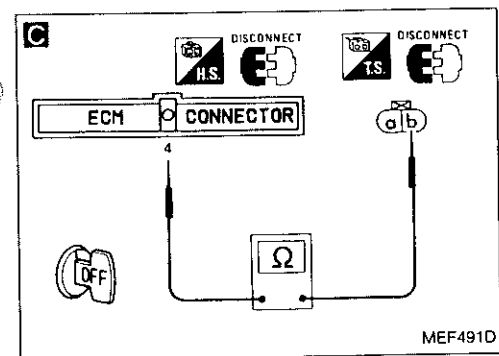

OK

**CHECK COMPONENT (IACV-AAC valve).**

Refer to "Electrical Components Inspection". (See page EC-204.)

NG → Replace IACV-AAC valve.

OK

Disconnect and reconnect harness connectors in the circuit. Then retest.

Trouble is not fixed.

Check ECM pin terminals for damage or the connection of ECM harness connector. Reconnect ECM harness connector and retest.

# TROUBLE DIAGNOSES

## Diagnostic Procedure 40

### IACV-FICD SOLENOID VALVE (Not self-diagnostic item)

LHD MODELS

EC-FICD-01

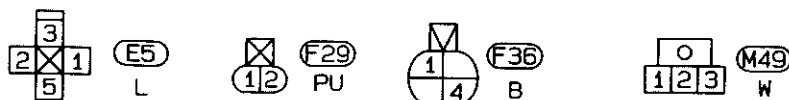
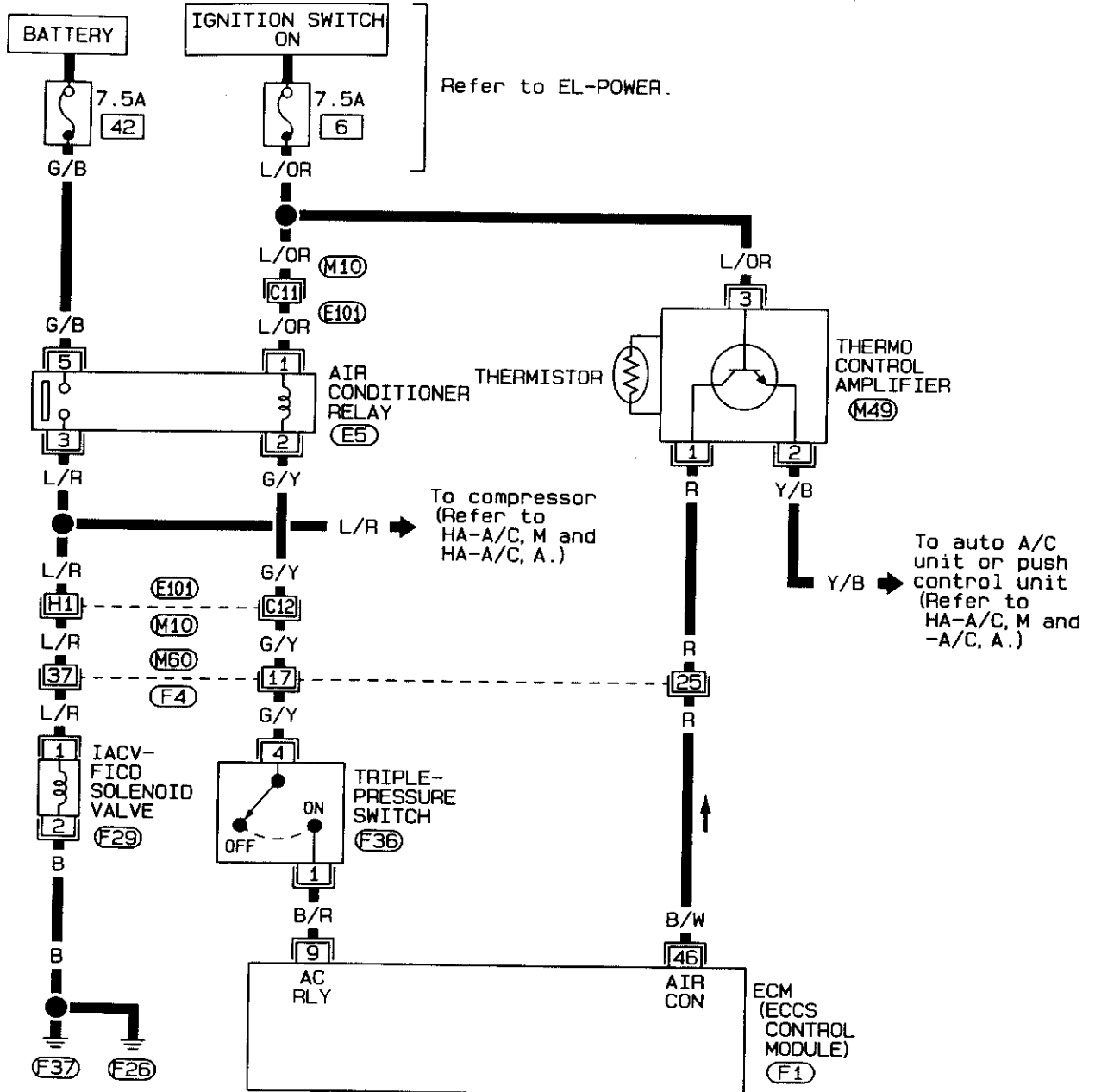

Refer to last page (Foldout page).

(M10), (E101)  
(M60), (F4)

101	102	103	104	105	106	107	108	1	2	3	4	5	6	7	8	9	10	21	22	23	24	25	26	27	28	29	30	41	42	43	44	45	46	47	48	49	50
109	110	111	112	113	114	115	116	11	12	13	14	15	16	17	18	19	20	31	32	33	34	35	36	37	38	39	40	51	52	53	54	55	56	57	58	59	60

(F1)  
L



SEF846P

## TROUBLE DIAGNOSES

### Diagnostic Procedure 40 (Cont'd)

RHD MODELS

EC-FICD-02

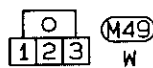
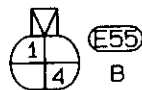
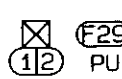
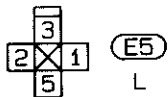
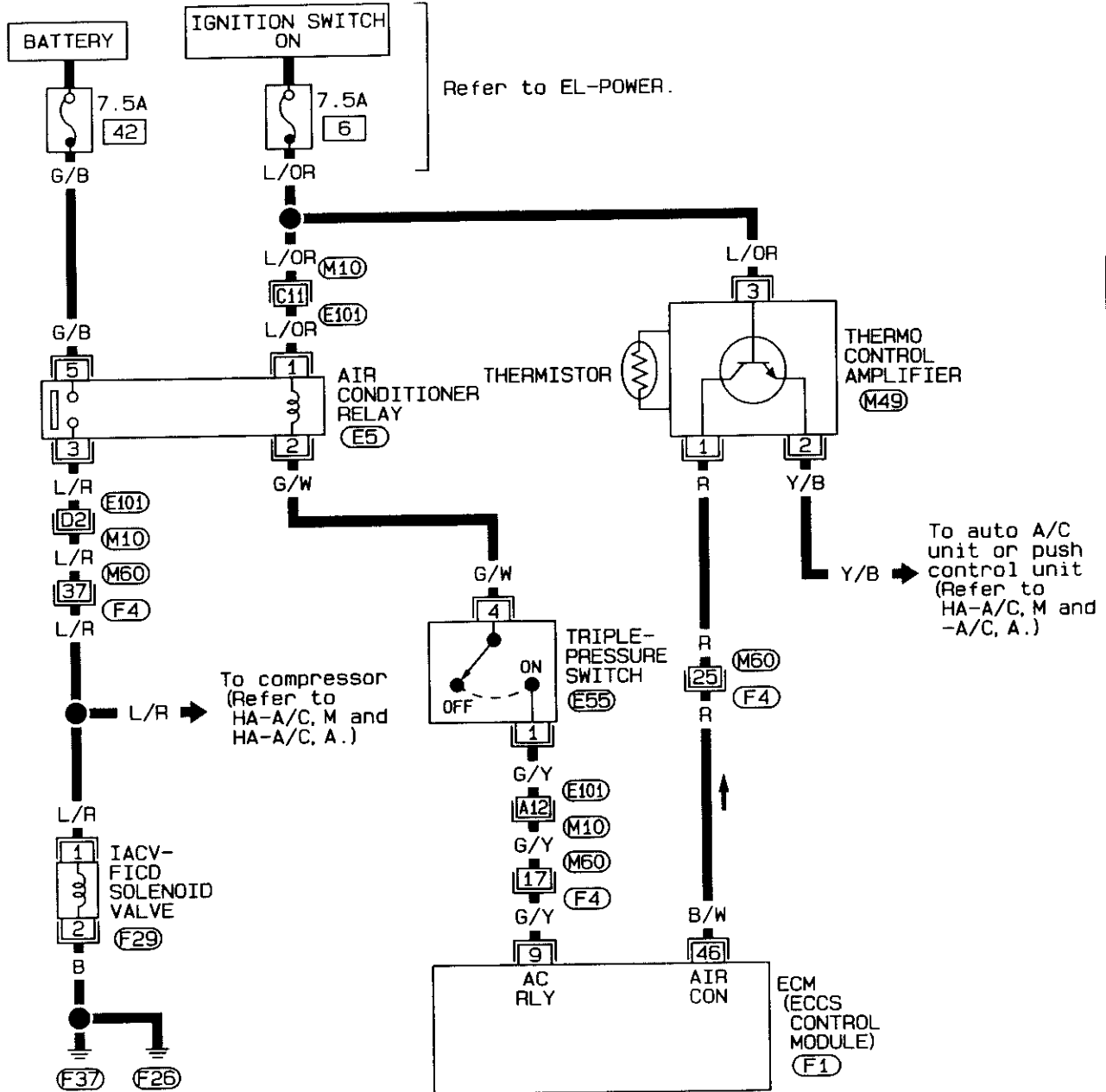

Refer to last page (Foldout page).

M10, E101  
M60, F4

101	102	103	104	105	106	107	108	1	2	3	4	5	6	7	8	9	10	11	12	13	14	15	16	17	18	19	20	21	22	23	24	25	26	27	28	29	30	31	32	33	34	35	36	37	38	39	40	41	42	43	44	45	46	47	48	49	50	
109	110	111	112	113	114	115	116																																																			

F1  
L



SEF847P

# TROUBLE DIAGNOSES

## Diagnostic Procedure 40 (Cont'd)

### Harness layout

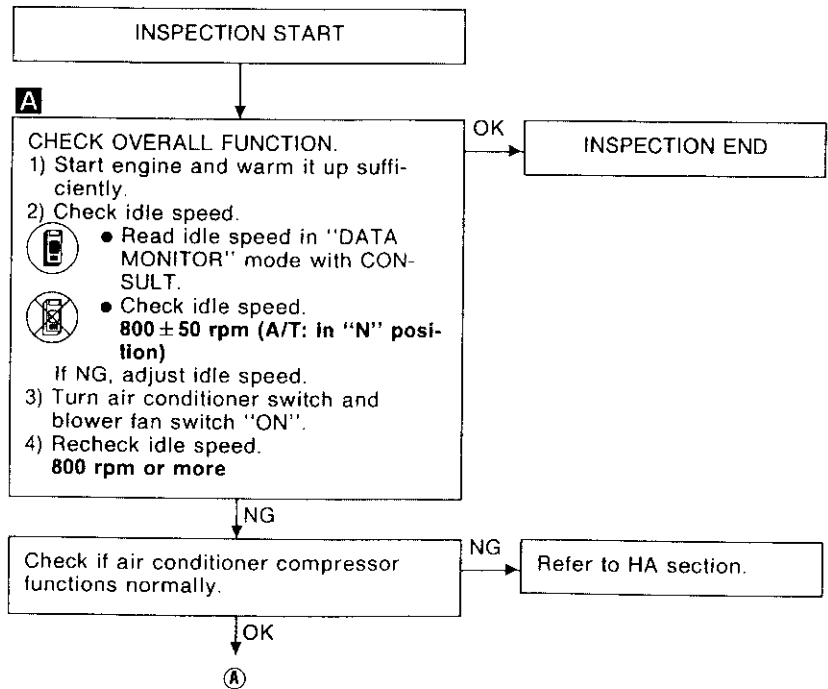
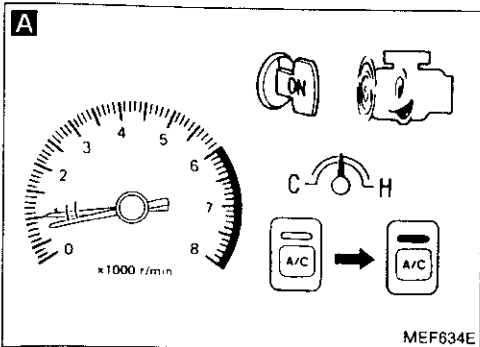
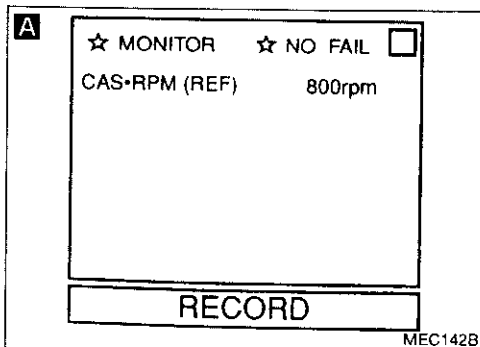
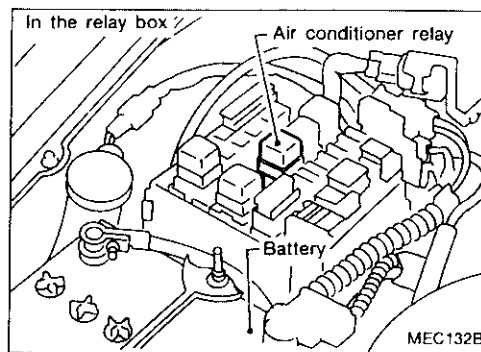
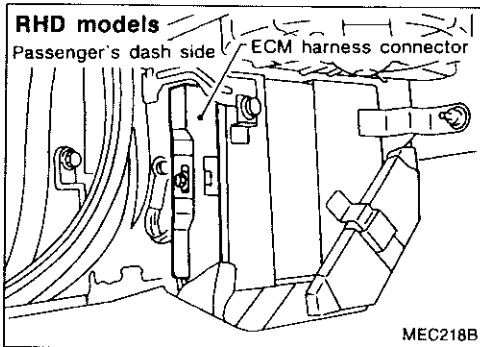
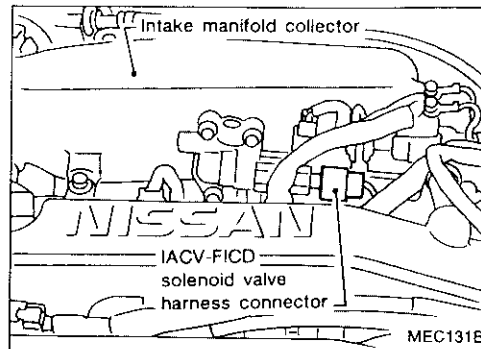
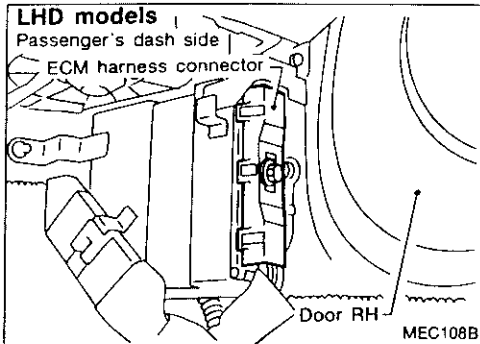

# TROUBLE DIAGNOSES

## Diagnostic Procedure 40 (Cont'd)

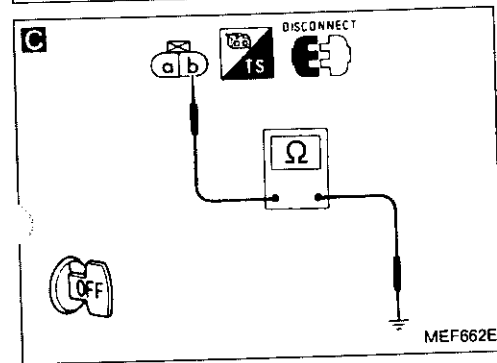
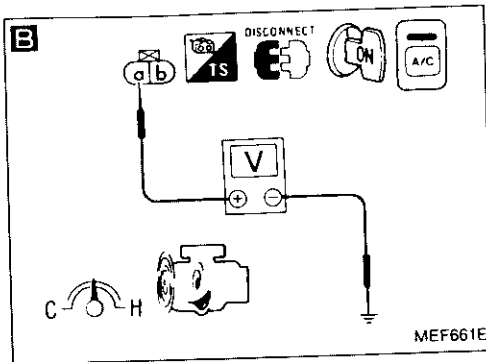

**B**

**CHECK POWER SUPPLY.**

- 1) Stop engine and turn air conditioner switch and blower fan switch "OFF".
- 2) Disconnect IACV-FICD solenoid valve harness connector.
- 3) Restart engine and turn air conditioner switch and blower fan switch "ON".
- 4) Check voltage between terminal (a) and ground.

**Voltage: Battery voltage**

NG

Check the following.

- Harness connectors (E101, M10)
- Harness connectors (M60, F4)
- Harness continuity between A/C relay and IACV-FICD solenoid valve

If NG, repair harness or connectors.

**C**

**CHECK GROUND CIRCUIT.**

- 1) Stop engine.
- 2) Check harness continuity between terminal (b) and engine ground.

**Continuity should exist.**

NG

Repair harness or connectors.

**CHECK COMPONENT**  
(IACV-FICD solenoid valve).  
Refer to "Electrical Components Inspection". (See page EC-205.)

NG

Replace IACV-FICD solenoid valve.

OK

Disconnect and reconnect harness connectors in the circuit. Then retest.

Trouble is not fixed.

Check ECM pin terminals for damage or the connection of ECM harness connector. Reconnect ECM harness connector and retest.

QI  
WA  
EW  
LC  
EC  
FE  
CL  
MT  
AT  
PD  
FA  
RA  
BR  
ST  
RS  
BT  
HA  
EL  
DX

# TROUBLE DIAGNOSES

## Diagnostic Procedure 41

### COOLING FAN CONTROL (Not self-diagnostic item)

EC-COOL/F-01

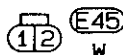
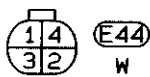
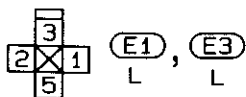
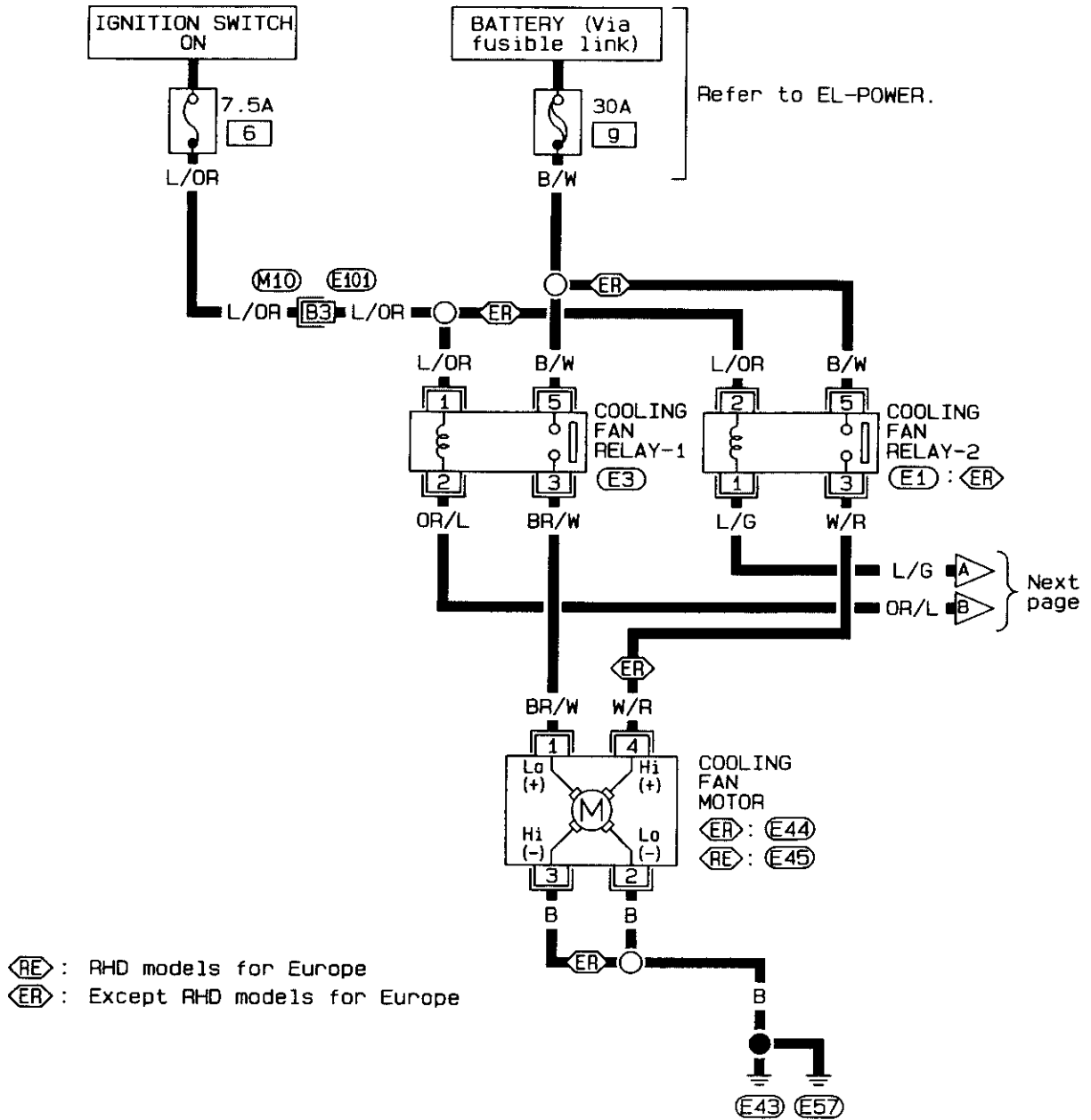

Refer to last page (Foldout page).

(M10), (E101)



# TROUBLE DIAGNOSES

## Diagnostic Procedure 41 (Cont'd)

EC-COOL/F-02

Preceding page

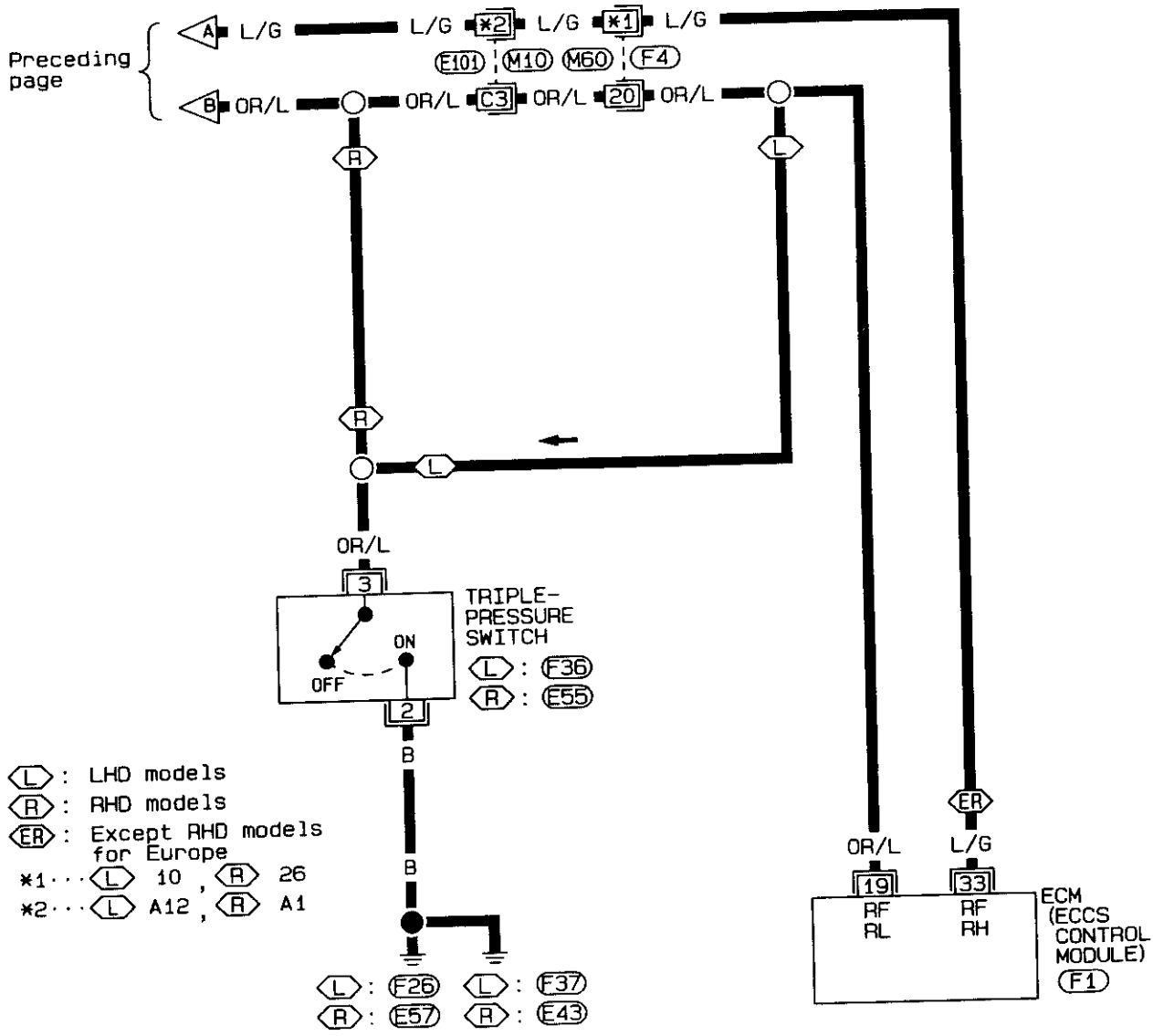

- (L) : LHD models
- (R) : RHD models
- (ER) : Except RHD models for Europe
- \*1... (L) 10, (R) 26
- \*2... (L) A12, (R) A1

- (L) : F36
- (R) : E55

- (L) : F26
- (R) : E57
- (L) : F37
- (R) : E43

Refer to last page (Foldout page).

- (M10), (E101)
- (M60), (F4)

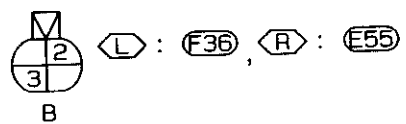

101	102	103	104	105	106	107	108	1	2	3	4	5	6	7	8	9	10	11	12	13	14	15	16	17	18	19	20	21	22	23	24	25	26	27	28	29	30	31	32	33	34	35	36	37	38	39	40	41	42	43	44	45	46	47	48	49	50	51	52	53	54	55	56	57	58	59	60
-----	-----	-----	-----	-----	-----	-----	-----	---	---	---	---	---	---	---	---	---	----	----	----	----	----	----	----	----	----	----	----	----	----	----	----	----	----	----	----	----	----	----	----	----	----	----	----	----	----	----	----	----	----	----	----	----	----	----	----	----	----	----	----	----	----	----	----	----	----	----	----

(F1)  
L



# TROUBLE DIAGNOSES

## Diagnostic Procedure 41 (Cont'd)

### Harness layout

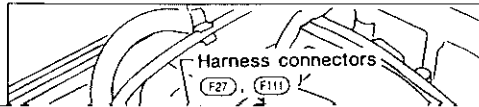
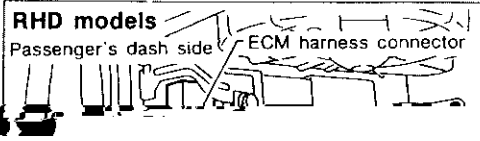
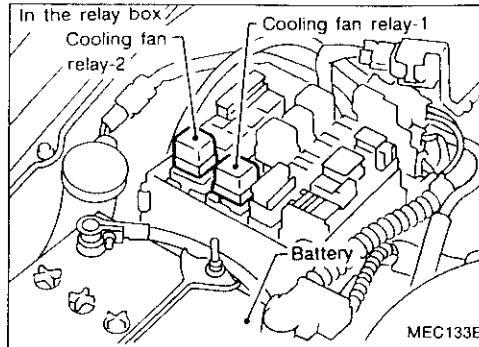
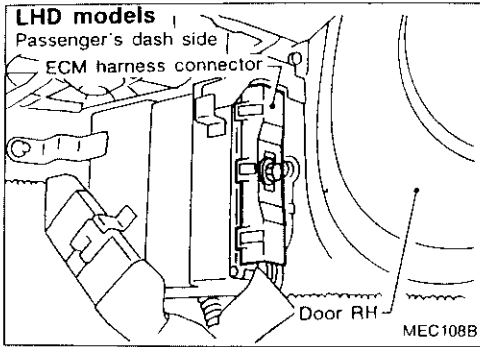

# TROUBLE DIAGNOSES

## Diagnostic Procedure 41 (Cont'd)

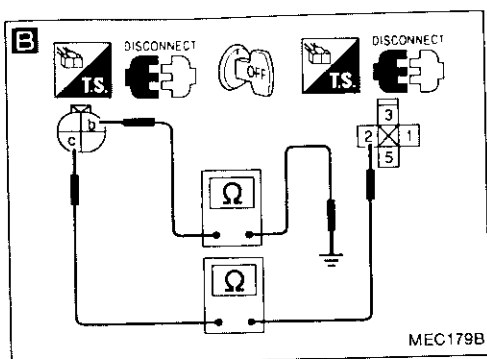

**B** CHECK HARNESS CONTINUITY BETWEEN COOLING FAN RELAY-1 AND GROUND.

- 1) Stop engine.
- 2) Disconnect cooling fan relay-1.
- 3) Disconnect triple-pressure switch harness connector.
- 4) Check harness continuity between terminal ② and terminal ⑤, terminal ① and body ground. **Continuity should exist.**

NG

Check the following.

- Harness connectors (E101), (M10) (LHD models)
- Harness connectors (M60), (F4) (LHD models)
- Harness continuity between cooling fan relay-1 and triple-pressure switch
- Harness continuity between triple-pressure switch and body ground.

If NG, repair harness or connectors.

OK

CHECK COMPONENT (Triple-pressure switch). Refer to "HA section".

NG

Replace triple-pressure switch.

OK

Go to "CHECK OUTPUT SIGNAL CIRCUIT" in **PROCEDURE A**.

CHECK OVERALL FUNCTION-II.

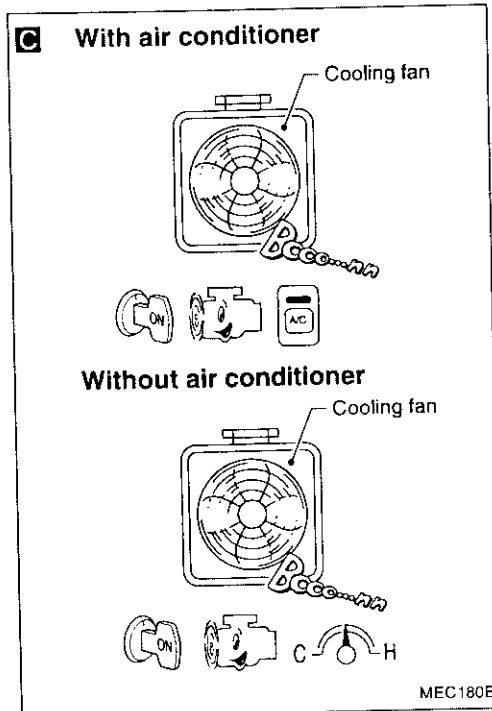

**C** CHECK COOLING FAN LOW SPEED OPERATION.

**With air conditioner**

- 1) Start engine.
- 2) Set temperature lever at full cold position.
- 3) Turn air conditioner switch "ON".
- 4) Turn blower fan switch "ON".
- 5) Run engine at idle for a few minutes with air conditioner operating.
- 6) Make sure that cooling fan operates at low speed.

**Without air conditioner**

- 1) Start engine.
- 2) Keep engine speed at about 2,000 rpm until engine is warmed up sufficiently.
- 3) Make sure that cooling fan begins to operate at low speed during warm-up.

NG

Check cooling fan low speed control circuit. (Go to **PROCEDURE A**.)

(RE) : RHD models for Europe  
(ER) : Except RHD models for Europe

OK

(RE)

INSPECTION END

(ER)

②

GI  
WA  
EW  
LC  
EC  
FE  
CL  
MT  
AT  
PD  
FA  
RA  
SR  
ST  
RS  
ST  
HA  
EL  
DX

# TROUBLE DIAGNOSES

## Diagnostic Procedure 41 (Cont'd)

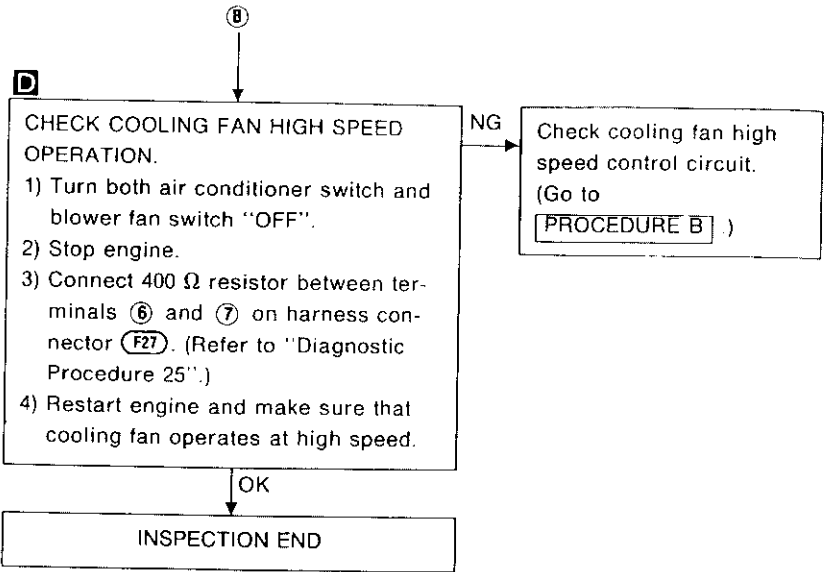
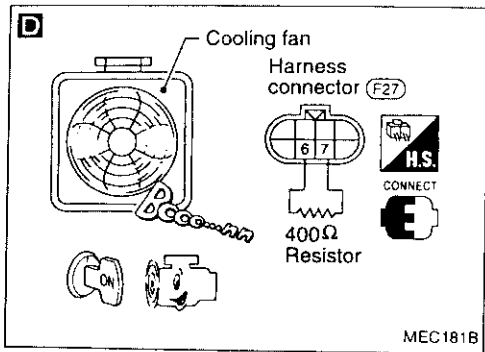

# TROUBLE DIAGNOSES

## Diagnostic Procedure 41 (Cont'd)

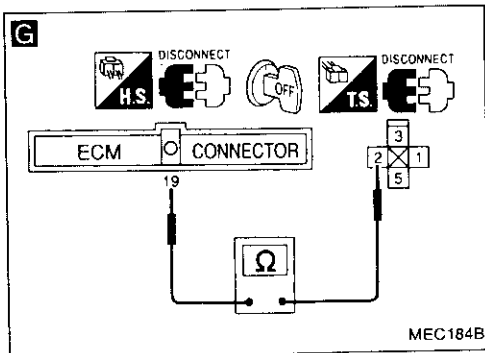
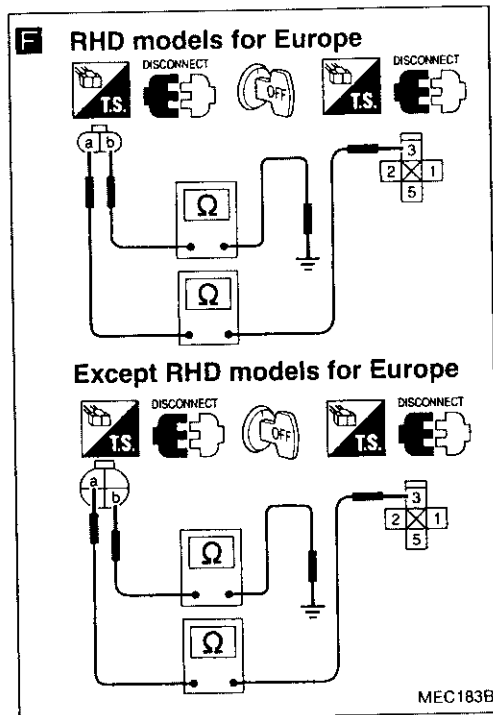
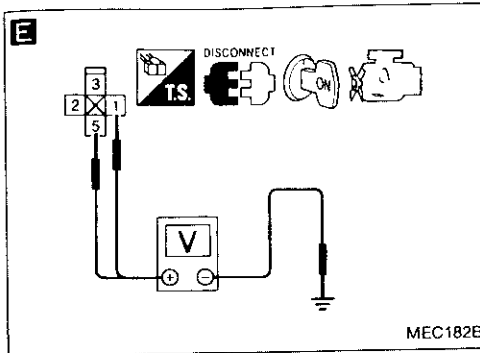

PROCEDURE A

INSPECTION START

**E**

CHECK POWER SUPPLY.

- 1) Stop engine.
- 2) Disconnect cooling fan relay-1.
- 3) Turn ignition switch "ON".
- 4) Check voltage between terminals ①, ⑤ and ground.

**Voltage: Battery voltage**

NG

Check the following.

- Harness connectors (M10, E101)
- 7.5A fuse
- 30A fusible link
- Harness continuity between cooling fan relay-1 and fuse
- Harness continuity between cooling fan relay-1 and fusible link

If NG, repair harness or connectors.

OK

**F**

CHECK GROUND CIRCUIT.

- 1) Turn ignition switch "OFF".
- 2) Disconnect cooling fan motor harness connector.
- 3) Check harness continuity between terminal ③ and terminal ④, terminal ⑥ and body ground.

**Continuity should exist.**

NG

Repair harness or connectors.

OK

**G**

CHECK OUTPUT SIGNAL CIRCUIT.

- 1) Disconnect ECM harness connector.
- 2) Check harness continuity between ECM terminal ⑱ and terminal ②.

**Continuity should exist.**

NG

Check the following.

- Harness connectors (E101, M10)
- Harness connectors (M60, F4)
- Harness continuity between ECM and cooling fan relay-1

If NG, repair harness or connectors.

OK

CHECK COMPONENT (Cooling fan relay-1). Refer to "Electrical Components Inspection". (See page EC-206.)

NG

Replace cooling fan relay.

OK

①

GI  
MA  
EM  
LC  
EC  
FE  
CL  
MT  
AT  
PD  
FA  
RA  
BR  
ST  
RS  
BT  
HA  
EL  
OX

# TROUBLE DIAGNOSES

## Diagnostic Procedure 41 (Cont'd)

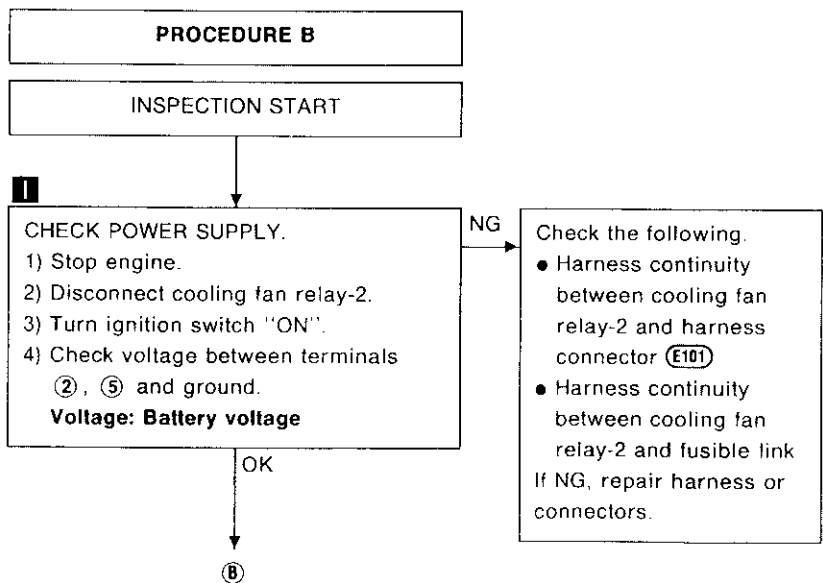
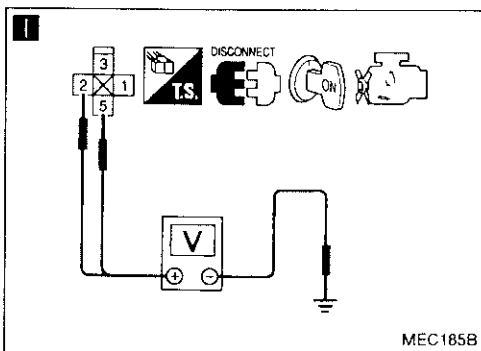
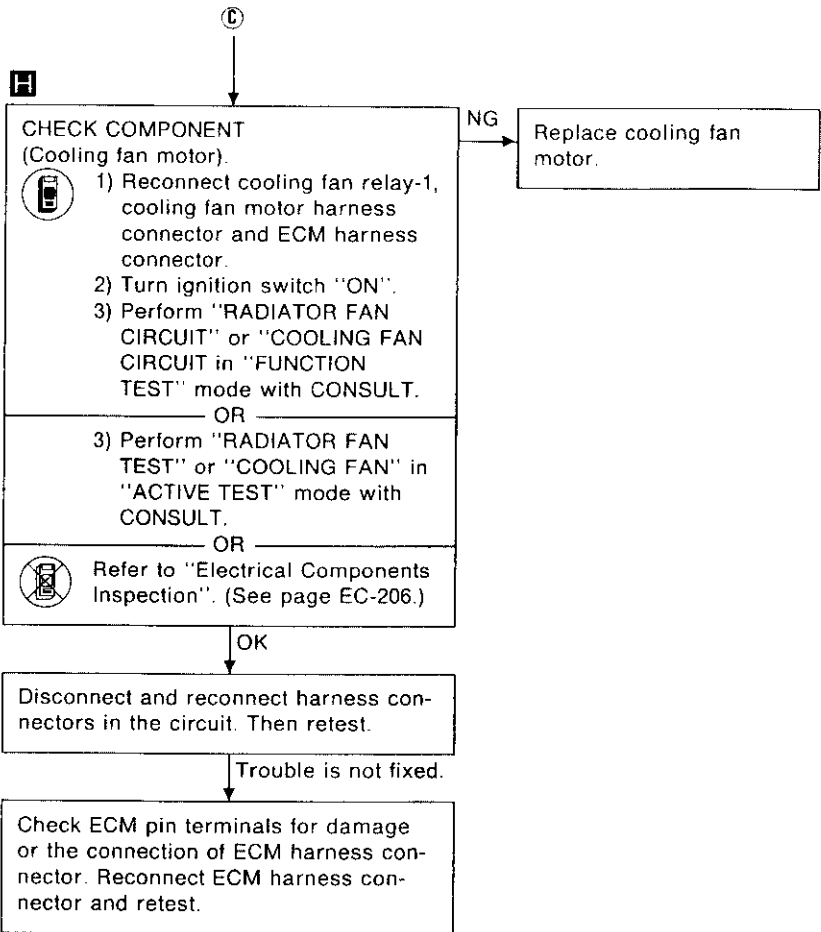
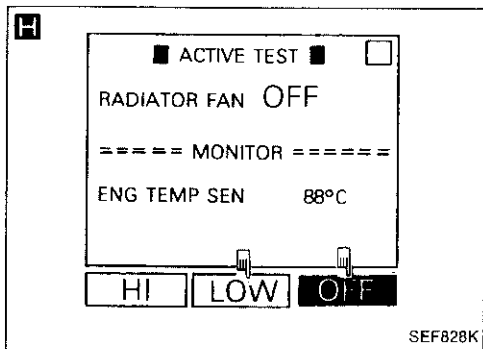
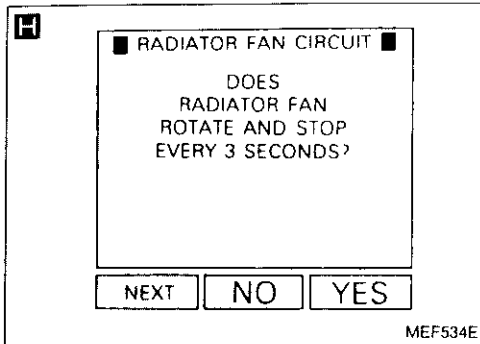

# TROUBLE DIAGNOSES

## Diagnostic Procedure 41 (Cont'd)

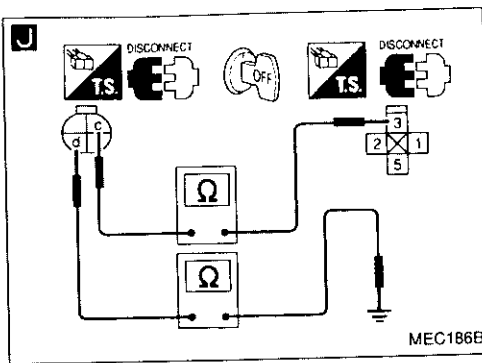

**J**

➔ (B)

**CHECK GROUND CIRCUIT.**  
 1) Turn ignition switch "OFF".  
 2) Disconnect cooling fan motor harness connector.  
 3) Check harness continuity between terminal ③ and terminal ②, terminal ④ and body ground.  
**Continuity should exist.**

NG → Repair harness or connectors.

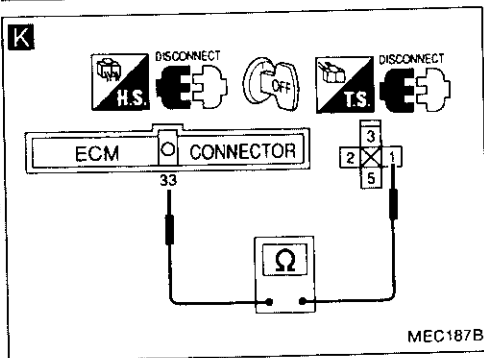

**K**

**CHECK OUTPUT SIGNAL CIRCUIT.**  
 1) Disconnect ECM harness connector.  
 2) Check harness continuity between ECM terminal ③ and terminal ①.  
**Continuity should exist.**

NG → Check the following.  
 • Harness connectors (E101, M10)  
 • Harness connectors (M60, F4)  
 • Harness continuity between ECM and cooling fan relay-2  
 If NG, repair harness or connectors.

OK → **CHECK COMPONENT (Cooling fan relay-2).**  
 Refer to "Electrical Components Inspection". (See page EC-206.)

NG → Replace cooling fan relay.

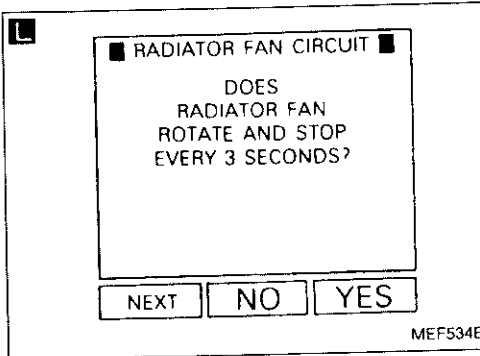

OK → **CHECK COMPONENT (Cooling fan motor).**  
 1) Reconnect cooling fan relay-2, cooling fan motor harness connector and ECM harness connector.  
 2) Disconnect 400 Ω resistor from harness connector (F27).  
 3) Turn ignition switch "ON".  
 4) Perform "RADIATOR FAN CIRCUIT" or "COOLING FAN CIRCUIT" in "FUNCTION TEST" mode with CONSULT.  
 OR  
 4) Perform "RADIATOR FAN TEST" or "COOLING FAN" in "ACTIVE TEST" mode with CONSULT.  
 OR  
 Refer to "Electrical Components Inspection". (See page EC-206.)

NG → Replace cooling fan motor.

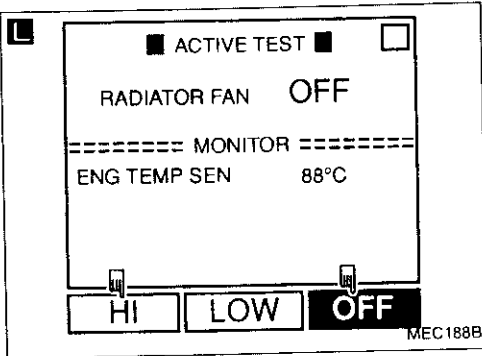

OK → Disconnect and reconnect harness connectors in the circuit. Then retest.

➔ Trouble is not fixed.  
 Check ECM pin terminals for damage or the connection of ECM harness connector. Reconnect ECM harness connector and retest.

# TROUBLE DIAGNOSES

## Diagnostic Procedure 42

### POWER STEERING OIL PRESSURE SWITCH (Not self-diagnostic item)

EC-PST/SW-01

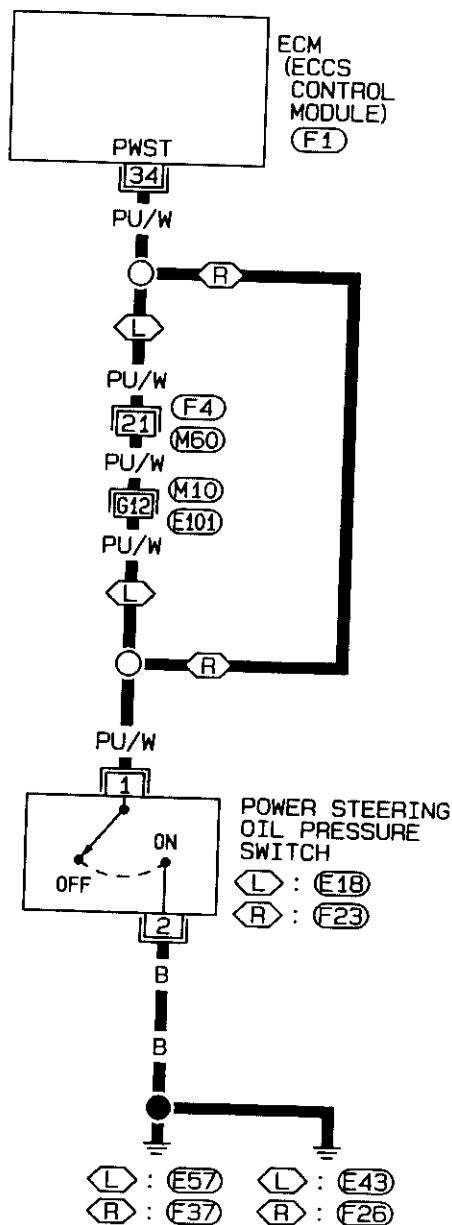

(L) : LHD models  
(R) : RHD models

[12] (L) : (E18), (R) : (F23)  
W

Refer to last page (Foldout page).

(M10), (E101)  
(M60), (F4)

101	102	103	104	105	106	107	108	1	2	3	4	5	6	7	8	9	10	21	22	23	24	25	26	27	28	29	30	41	42	43	44	45	46	47	48	49	50
109	110	111	112	113	114	115	116	11	12	13	14	15	16	17	18	19	20	31	32	33	34	35	36	37	38	39	40	51	52	53	54	55	56	57	58	59	60

(F1)  
L



SEF848P



# TROUBLE DIAGNOSES

## Diagnostic Procedure 42 (Cont'd)

### Harness layout

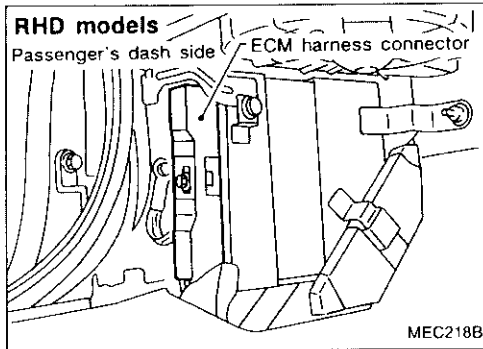
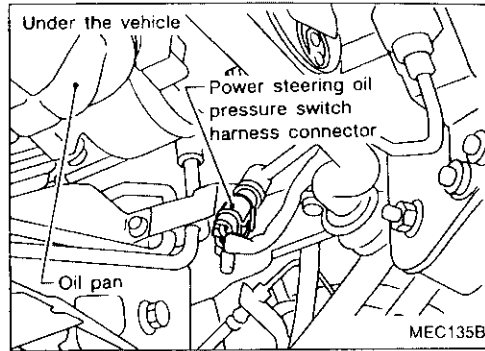
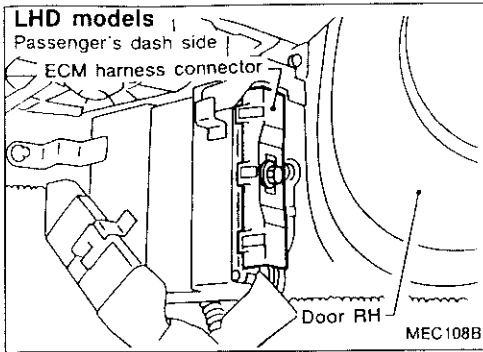

EC

ME

ECM

LC

**EC**

FE

CL

MT

AT

PD

EA

EA

SR

MT

EA

ST

EA

EL

ECM

# TROUBLE DIAGNOSES

## Diagnostic Procedure 42 (Cont'd)

**A**

■ PW/ST SIGNAL CIRCUIT ■

HOLD STEERING WHEEL  
IN A FULL  
LOCKED POSITION  
THEN  
TOUCH START

NEXT    START

SEF200L

**A**

☆ MONITOR    ☆ NO FAIL    □

PW/ST SIGNAL    OFF

RECORD

SEF831K

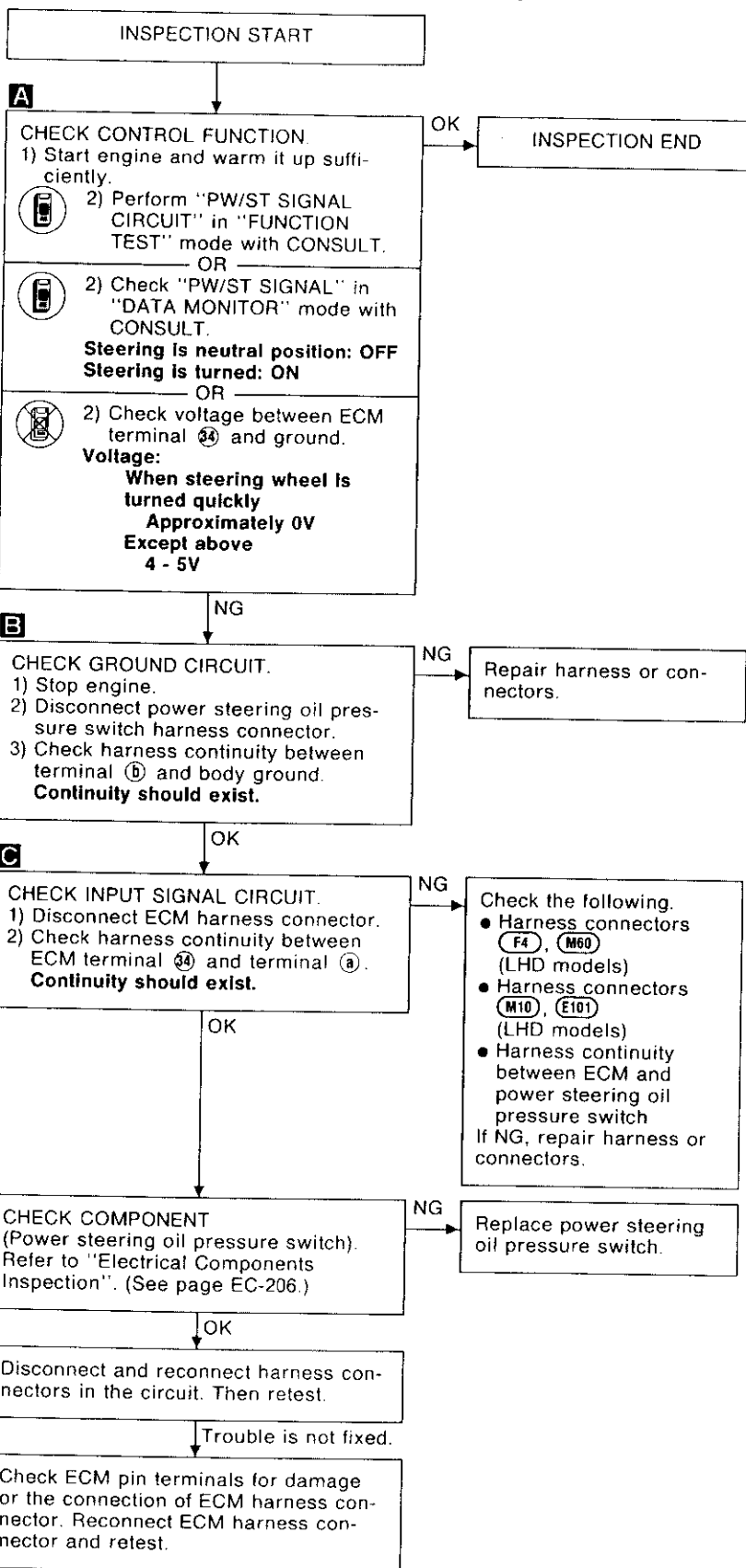
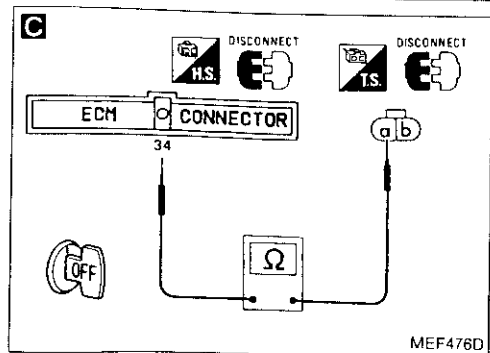
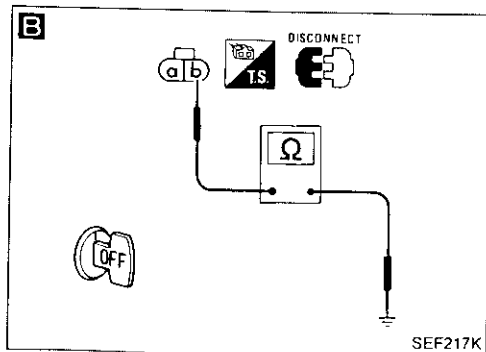
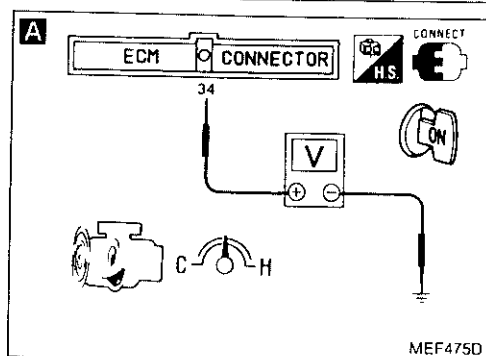

# TROUBLE DIAGNOSES

## Diagnostic Procedure 43

NEUTRAL POSITION SWITCH & A/T CONTROL UNIT (PARK/NEUTRAL POSITION SIGNAL)  
(Not self-diagnostic item)

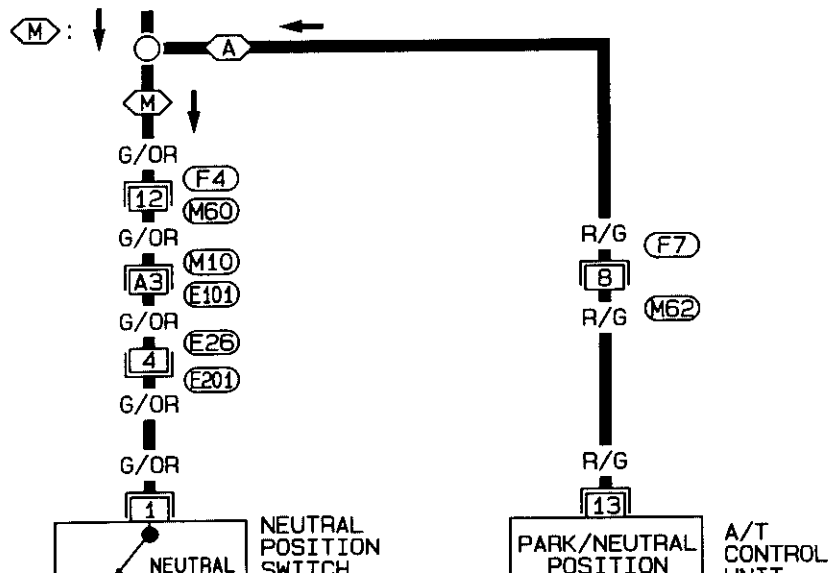

EC

PT

CL

MT

ST

PD

# TROUBLE DIAGNOSES

## Diagnostic Procedure 43 (Cont'd)

### Harness layout

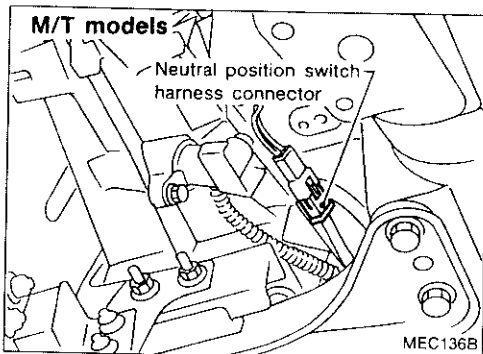
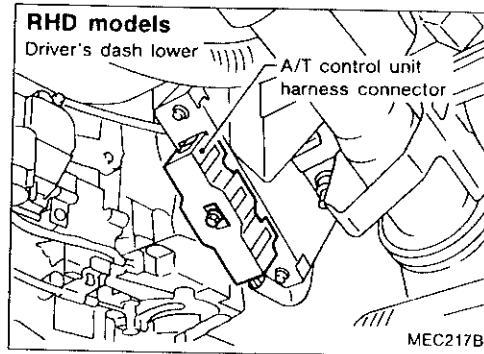
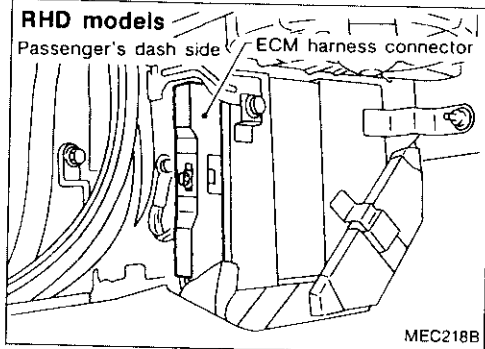
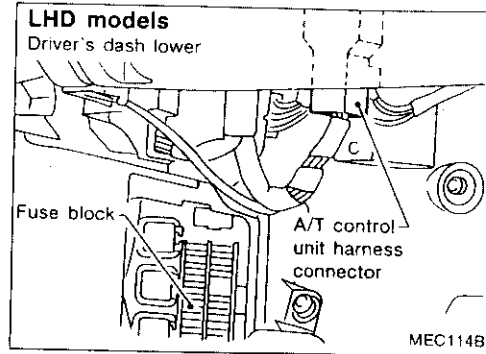
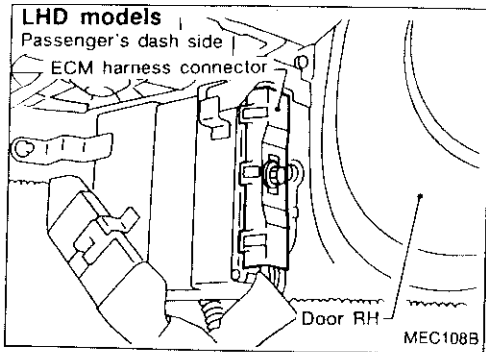

# TROUBLE DIAGNOSES

## Diagnostic Procedure 43 (Cont'd)

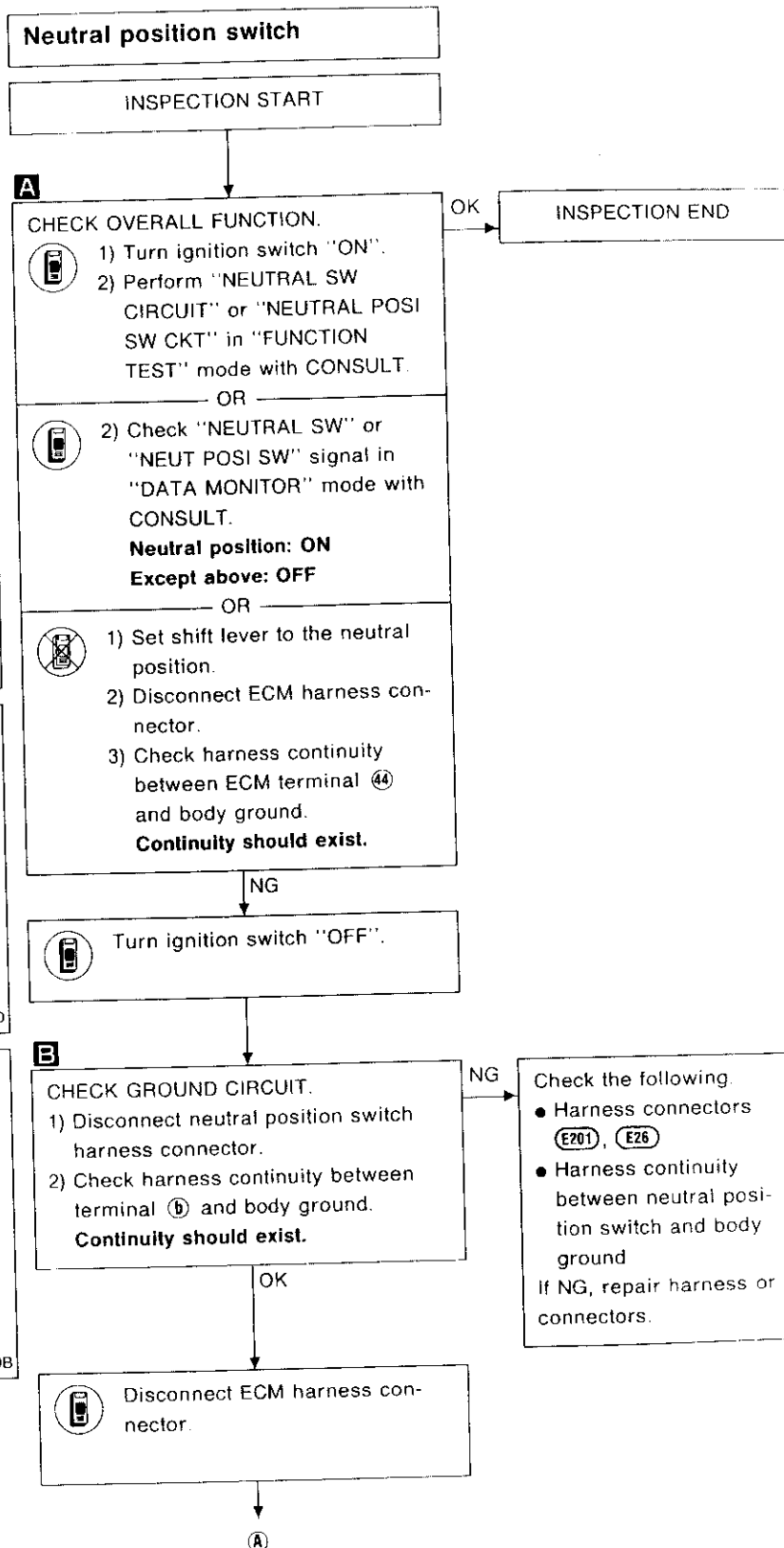
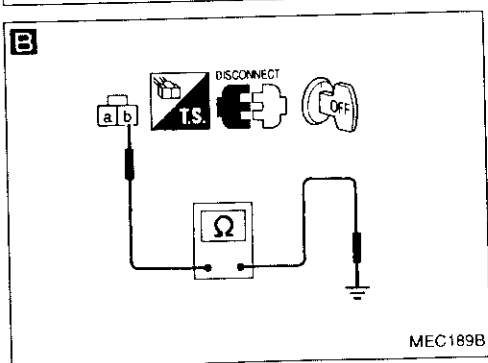
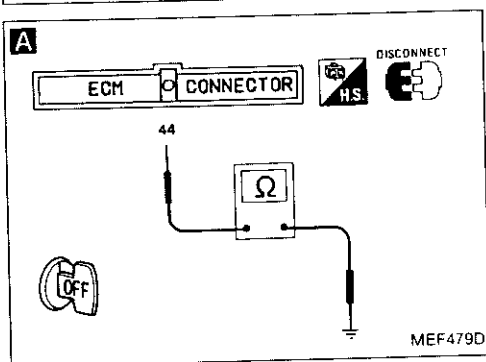
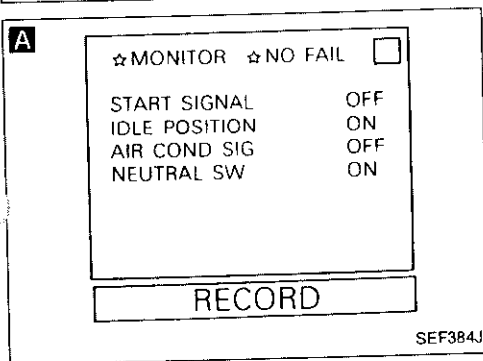
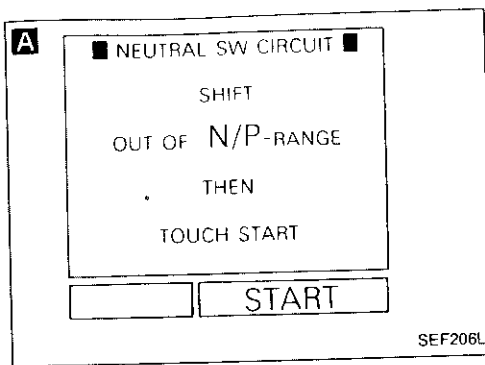

# TROUBLE DIAGNOSES

## Diagnostic Procedure 43 (Cont'd)

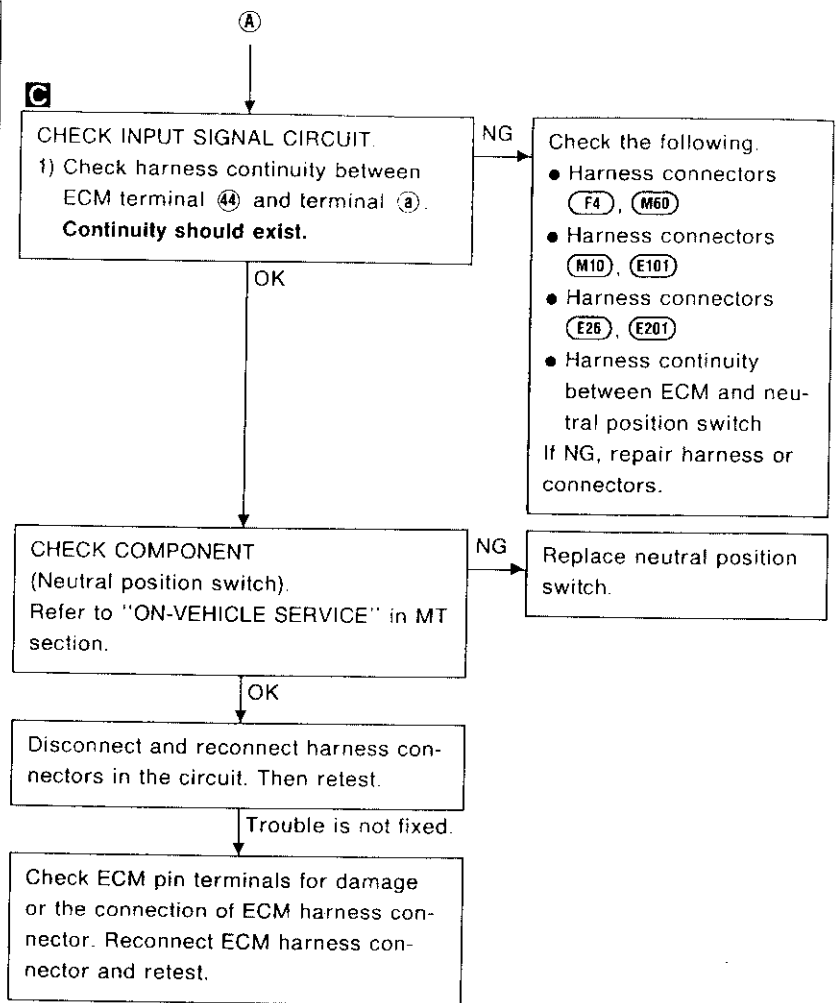
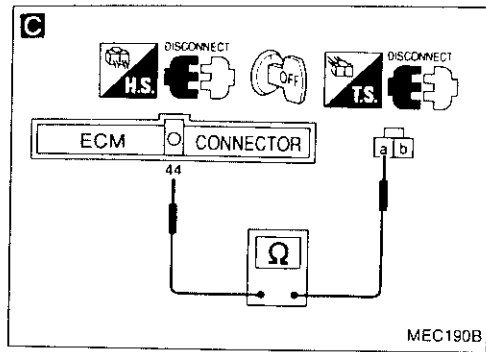

# TROUBLE DIAGNOSES

## Diagnostic Procedure 43 (Cont'd)

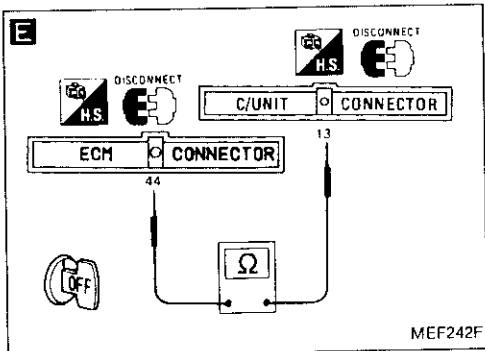
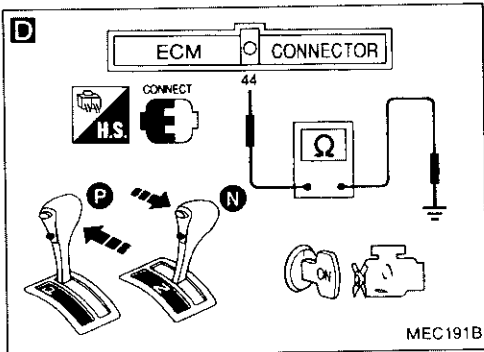
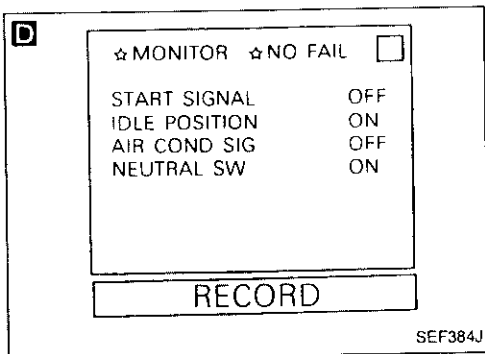
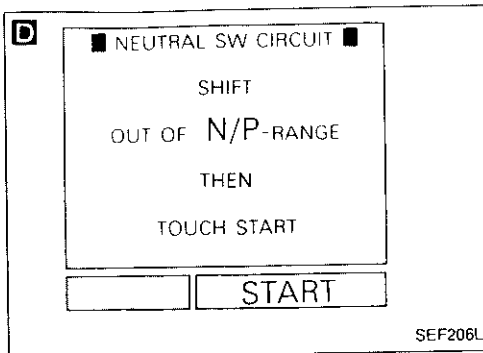

### A/T CONTROL UNIT (PARK/NEUTRAL POSITION SIGNAL) CIRCUIT

INSPECTION START

**D** CHECK OVERALL FUNCTION.

- 1) Turn ignition switch "ON".
- 2) Perform "NEUTRAL SW CIRCUIT" or "NEUTRAL POSI SW CKT" in "FUNCTION TEST" mode with CONSULT.

OK → INSPECTION END

OR

**D** 2) Check "NEUTRAL SW" or "NEUT POSI SW" signal in "DATA MONITOR" mode with CONSULT.

"N" or "P": ON

Except above: OFF

OR

**D** 2) Check voltage between ECM terminal 44 and ground under the following conditions.

Voltage:

"N" or "P" Approximately 0V

Except above Approximately 5V

**E** CHECK INPUT SIGNAL CIRCUIT.

- 1) Turn ignition switch "OFF".
- 2) Disconnect ECM harness connector.
- 3) Disconnect A/T control unit harness connector.
- 4) Check harness continuity between ECM terminal 44 and terminal 13. Continuity should exist.

NG → Check the following.

- Harness connectors (F7), (M62)
- Harness continuity between ECM and A/T control unit

If NG, repair harness or connectors.

OK → CHECK INHIBITOR SWITCH FUNCTION. Make sure that inhibitor switch functions properly. (Refer to AT section).

NG → Check inhibitor switch and circuit (Refer to AT section.)

OK → Disconnect and reconnect harness connectors in the circuit. Then retest.

Trouble is not fixed. → Check ECM pin terminals for damage or the connection of ECM harness connector. Reconnect ECM harness connector and retest.

TROUBLE DIAGNOSES

Diagnostic Procedure 44

REAR WINDOW DEFOGGER SWITCH (Not self-diagnostic item)

EC-DEF/S-01

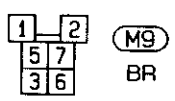
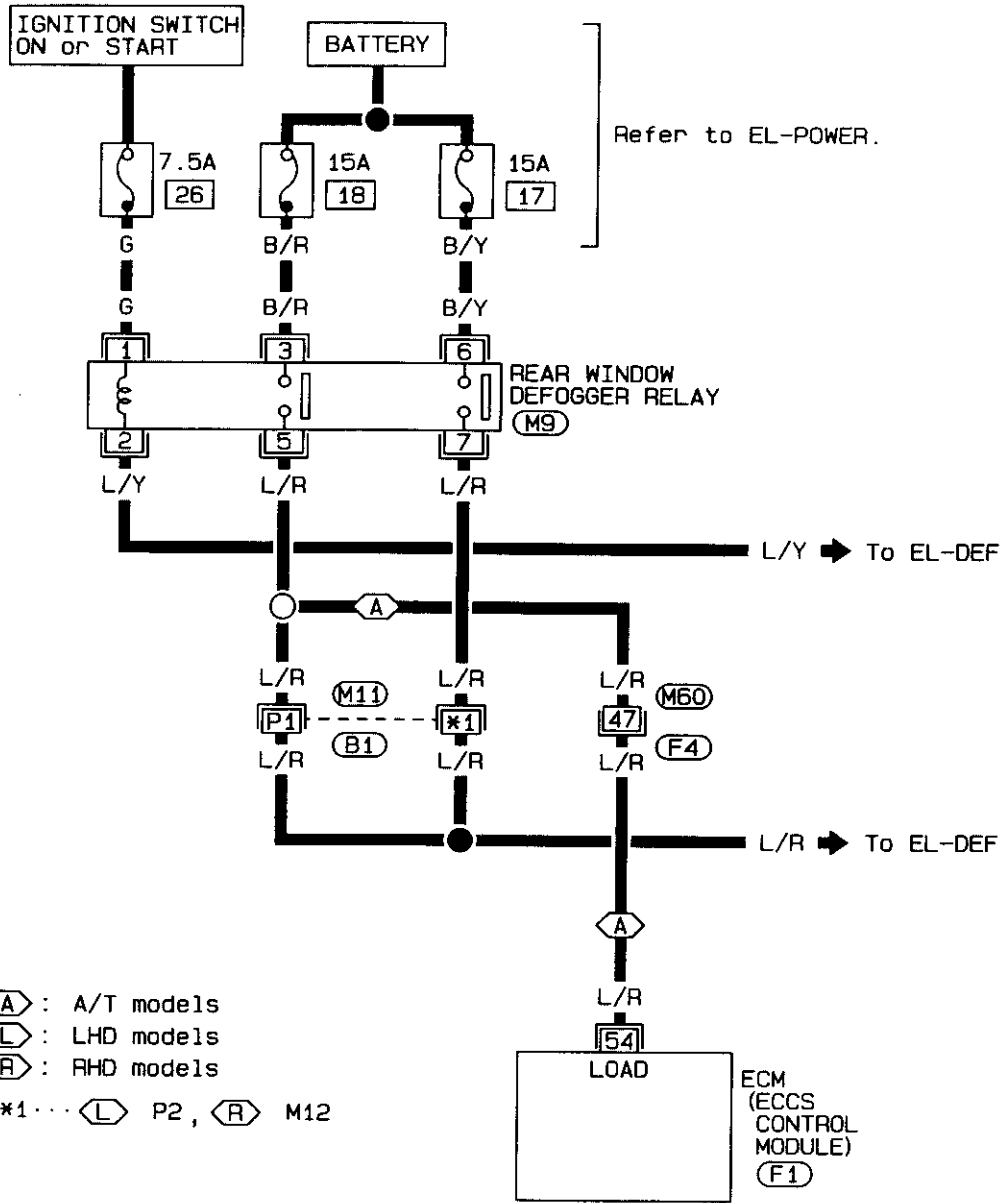

Refer to last page (Foldout page).

(M11), (B1)  
 (M60), (F4)

101	102	103	104	105	106	107	108	1	2	3	4	5	6	7	8	9	10	( )	21	22	23	24	25	26	27	28	29	30	41	42	43	44	45	46	47	48	49	50
109	110	111	112	113	114	115	116	11	12	13	14	15	16	17	18	19	20	( )	31	32	33	34	35	36	37	38	39	40	51	52	53	54	55	56	57	58	59	60

(F1)  
 L



# TROUBLE DIAGNOSES

## Diagnostic Procedure 44 (Cont'd)

### Harness layout

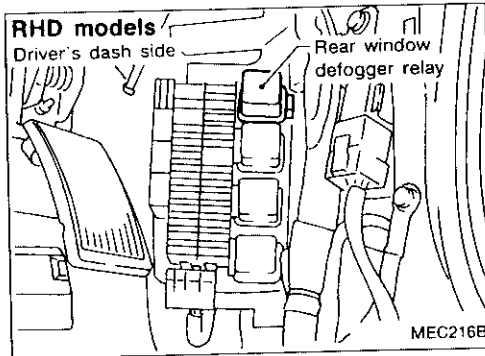
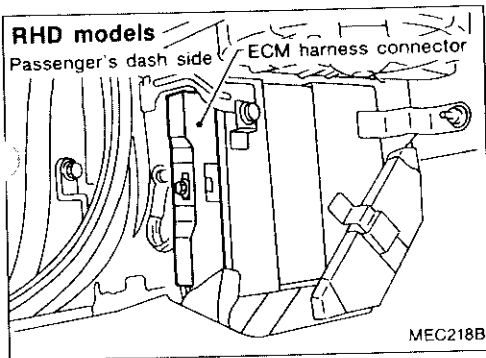
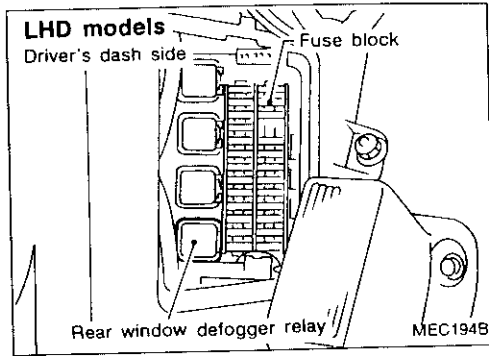
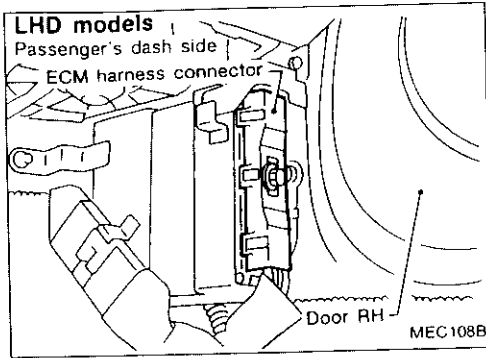

SI

MA

EM

LC

**EC**

FE

CL

WT

AT

PD

FA

PA

SP

ST

RS

BT

HA

EL

IDX

# TROUBLE DIAGNOSES

## Diagnostic Procedure 44 (Cont'd)

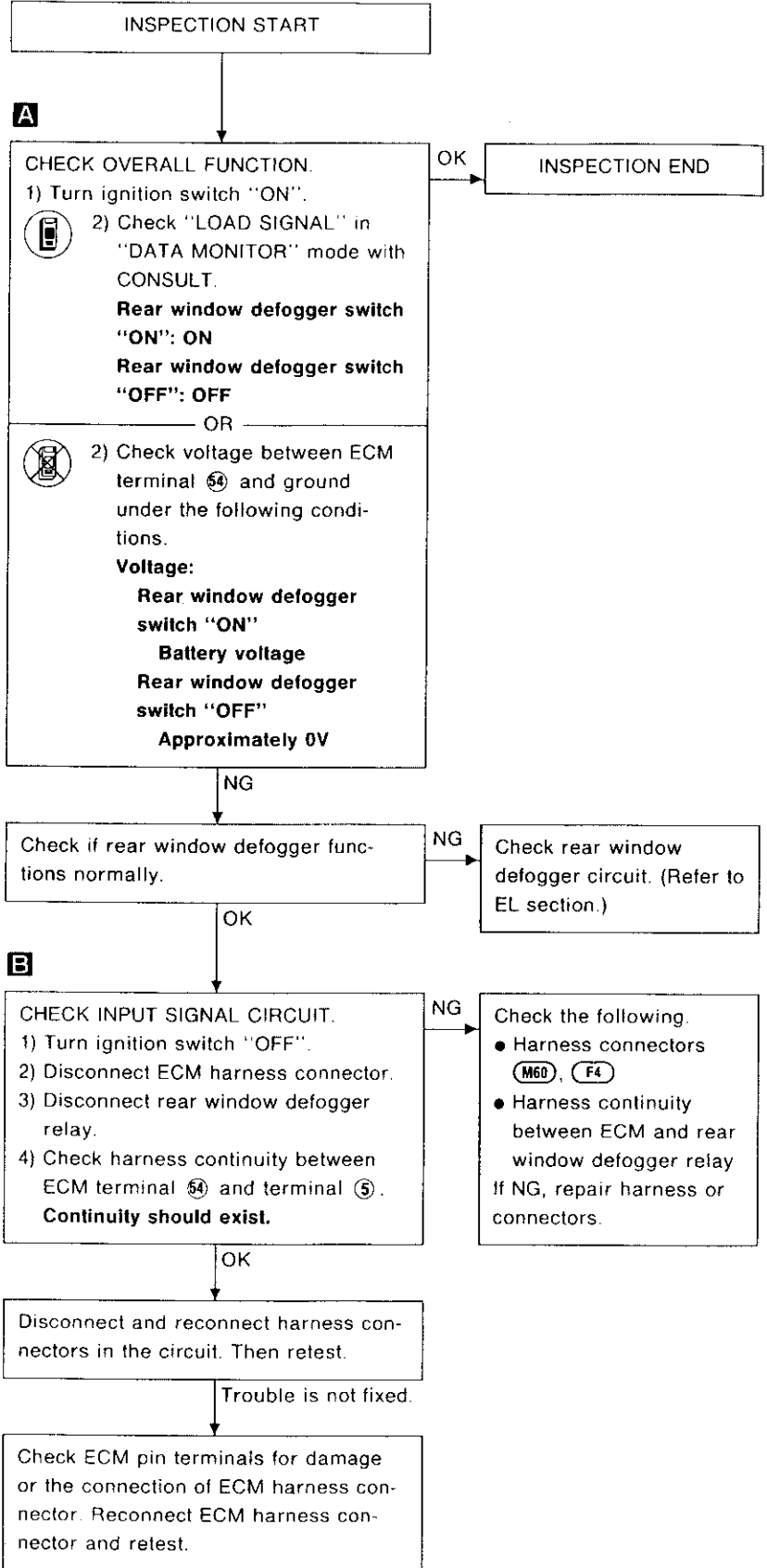
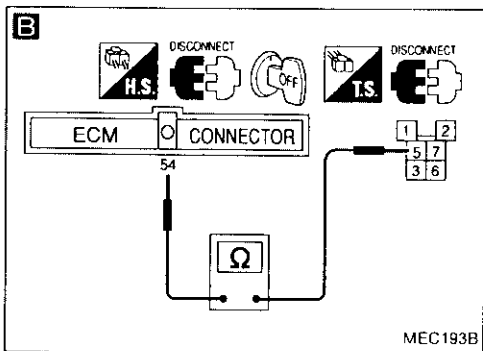
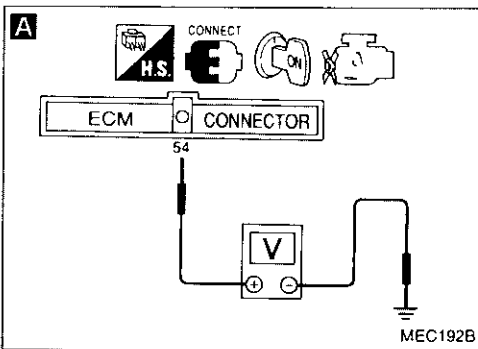
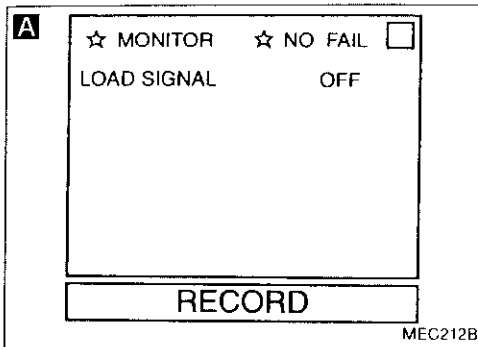

# TROUBLE DIAGNOSES

## Diagnostic Procedure 45

MALFUNCTION INDICATOR LAMP & DATA LINK CONNECTOR FOR CONSULT (Not self-diagnostic item)

EC-MIL-01

IGNITION SWITCH  
ON or START

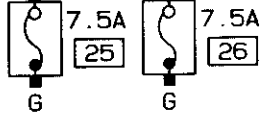

Refer to EL-POWER.

(L) : LHD models  
(R) : RHD models

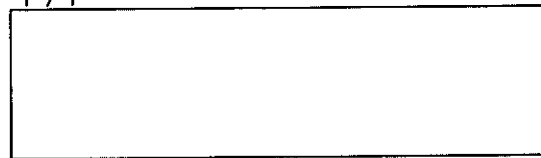
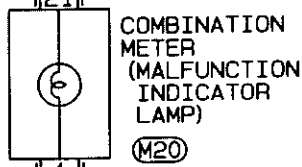

DATA LINK  
CONNECTOR  
FOR CONSULT  
(MB)

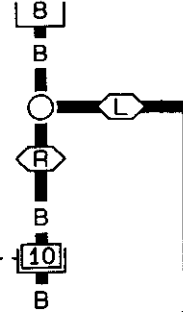
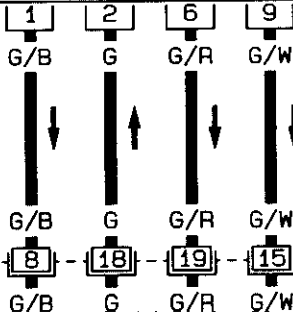
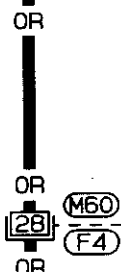

S  
MI  
EM  
IC  
EC  
EF  
CL  
MT  
AT  
FD  
FA

## TROUBLE DIAGNOSES

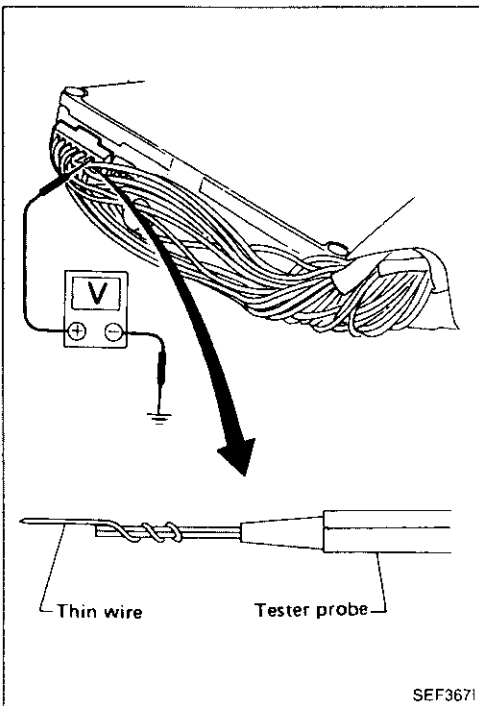
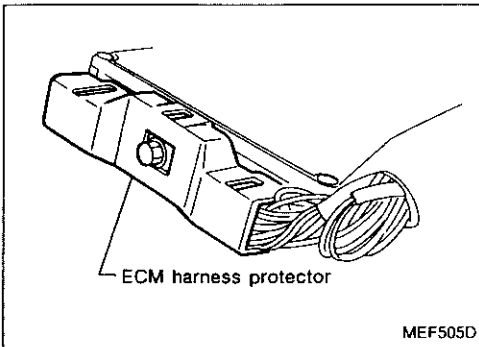
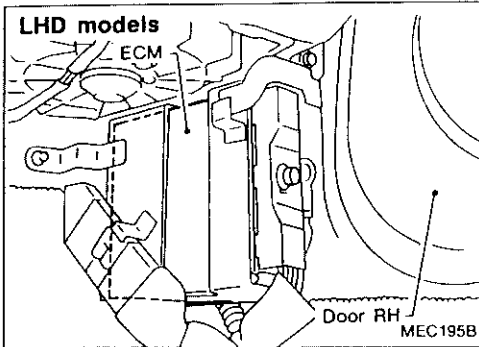

### Electrical Components Inspection

#### ECM INPUT/OUTPUT SIGNAL INSPECTION

1. ECM is located at passenger's dash side. For this inspection, remove the passenger's dash side cover.
2. Remove ECM harness protector.
3. Perform all voltage measurements with the connectors connected.  
Extend tester probe as shown to perform tests easily.

#### ECM HARNESS CONNECTOR TERMINAL LAYOUT

101	102	103	105	107	108	1	2	4	5	7	9	10	21	22	23	25	26	27	28	29	30	41	42	43	44	45	46	47	48	49	50
109	110	112	113	115	116	11	12	14	15	16	18	19	20	31	32	33	34	35	36	38	51	52	53	54	56	58	59	60			



MEC196B

## TROUBLE DIAGNOSES

### Electrical Components Inspection (Cont'd)

\*Data are reference values.

TER-MINAL NO.	ITEM	CONDITION	*DATA
19	Cooling fan (Low speed)	Engine is running. └ Cooling fan is not operating.	BATTERY VOLTAGE (11 - 14V)
		Engine is running. └ Cooling fan is operating.	Approximately 0V
23	Knock sensor	Engine is running.	2.0 - 3.0V
25	Wastegate valve control solenoid valve	Engine is running. └ Idle speed	BATTERY VOLTAGE (11 - 14V)
		Engine is running. └ Engine is racing up to 5,000 rpm.	Approximately 5V
27	Mass air flow sensor	Engine is running. (Warm-up condition) └ Idle speed	0.8 - 1.5V
		Engine is running. (Warm-up condition) └ Engine speed is 3,000 rpm.	1.4 - 2.0V
28	Engine coolant temperature sensor	Engine is running.	0 - 5.0V Output voltage varies with engine coolant temperature.
29	Heated oxygen sensor	Engine is running. └ After warming up sufficiently and engine speed is 2,000 rpm.	0 - 0.3V ↔ 0.6 - 0.9V
33	Cooling fan (High speed)	Engine is running. └ Cooling fan is not operating. └ Cooling fan is operating at low speed.	BATTERY VOLTAGE (11 - 14V)
		Engine is running. └ Cooling fan is operating at high speed.	Approximately 0V
34	Power steering oil pressure switch	Engine is running. └ Steering wheel stays straight.	4.0 - 5.0V
		Engine is running. └ Steering wheel is turned.	Approximately 0V
35	Boost pressure sensor	Engine is running. └ Idle speed	Approximately 2V
		Engine is running. └ Engine is racing up to 4,000 rpm.	Approximately 2.2V

## TROUBLE DIAGNOSES

### Electrical Components Inspection (Cont'd)

\*Data are reference values.

TER-MINAL NO.	ITEM	CONDITION	*DATA
38	Throttle position sensor	Ignition switch "ON"	0.35 - 4.0V Output voltage varies with throttle valve opening angle.
41 51	Camshaft position sensor (Reference signal)	Engine is running. └ Do not run engine at high speed under no-load.	0.3 - 0.6V Output voltage slightly varies with engine speed.
42 52	Camshaft position sensor (Position signal)	Engine is running. └ Do not run engine at high speed under no-load.	2.0 - 3.0V Output voltage slightly varies with engine speed.
43	Start signal	Ignition switch "ON"	0V
		Ignition switch "START"	BATTERY VOLTAGE (11 - 14V)
44	Neutral position switch (M/T models) A/T control unit (A/T models)	Ignition switch "ON" └ Gear position is "Neutral position" (M/T models). └ Gear position is "N" or "P" (A/T models).	0V
		Ignition switch "ON" └ Except the above conditions	4.0 - 5.0V
45	Ignition switch	Ignition switch "ON"	BATTERY VOLTAGE (11 - 14V)
46	Air conditioner switch	Engine is running. └ Air conditioner switch is "OFF".	BATTERY VOLTAGE (11 - 14V)
		Engine is running. └ Both air conditioner switch and blower fan switch are "ON".	Approximately 0V
48	Power source for sensors	Ignition switch "ON"	Approximately 5.0V
49 59	Power source for ECM	Ignition switch "ON"	BATTERY VOLTAGE (11 - 14V)
54	Load signal	Ignition switch "ON" └ Rear window defogger switch is "ON".	BATTERY VOLTAGE (11 - 14V)
		Ignition switch "ON" └ Rear window defogger switch is "OFF".	Approximately 0V
58	Power supply (Back-up)	Ignition switch "OFF"	BATTERY VOLTAGE (11 - 14V)

## TROUBLE DIAGNOSES

### Electrical Components Inspection (Cont'd)

\*Data are reference values.

TER-MINAL NO.	ITEM	CONDITION	*DATA
101 103 110 112	Injectors	Engine is running.	BATTERY VOLTAGE (11 - 14V)
102	EGR & canister control solenoid valve	Engine is running. (Warm-up condition) └ Idle speed	Approximately 0V
		Engine is running. (Warm-up condition) └ Engine speed is 2,000 rpm.	BATTERY VOLTAGE (11 - 14V)
113	VTC solenoid valve	Engine is running. (Jack-up condition) └ Idle speed	BATTERY VOLTAGE (11 - 14V)
		Engine is running. (Jack-up condition) └ Engine is racing up to 2,000 rpm.	Approximately 0V
115	Heated oxygen sensor heater	Engine is running. └ Engine speed is between idle and 4,000 rpm.	Approximately 0V
		Engine is running. └ Engine speed is above 4,000 rpm.	BATTERY VOLTAGE (11 - 14V)

## TROUBLE DIAGNOSES

### Electrical Components Inspection (Cont'd) CAMSHAFT POSITION SENSOR

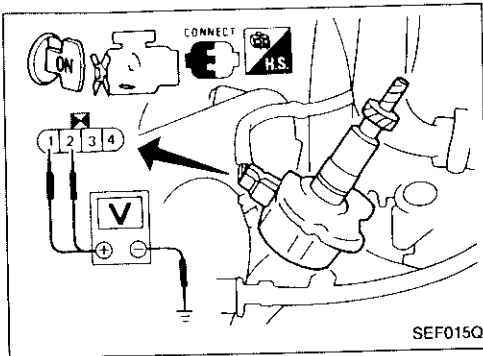

1. Remove camshaft position sensor from engine. (Camshaft position sensor harness connector should remain connected.)
2. Turn ignition switch "ON".
3. Rotate camshaft position sensor shaft slowly by hand and check voltage between terminals ①, ② and ground.

Terminal	Voltage
① (180° signal)	Voltage fluctuates between 5V and 0.1V.
② (1° signal)	

If NG, replace camshaft position sensor.

**After this inspection, diagnostic trouble code No. 11 might be displayed though the camshaft position sensor is functioning properly. In this case erase the stored memory.**

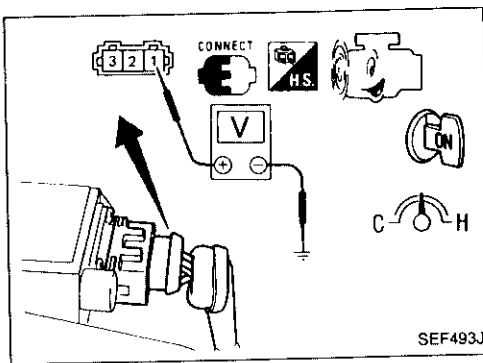

### MASS AIR FLOW SENSOR

1. Fold back mass air flow sensor harness connector rubber as shown in the figure if the harness connector is connected.
2. Turn ignition switch "ON".
3. Start engine and warm it up sufficiently.
4. Check voltage between terminal ① and ground.

Conditions	Voltage V
Idle speed	0.8 - 1.5
3,000 rpm	1.4 - 2.0

5. If NG, remove mass air flow sensor from air duct. Check ~~the air flow sensor product~~



### ENGINE COOLANT TEMPERATURE SENSOR

1. Disconnect engine coolant temperature sensor harness connector.
2. Check resistance as shown in the figure.

Temperature °C (°F)	Resistance kΩ
20 (68)	2.1 - 2.9
50 (122)	0.68 - 1.00



## TROUBLE DIAGNOSES

### Electrical Components Inspection (Cont'd)

#### IGNITION COIL

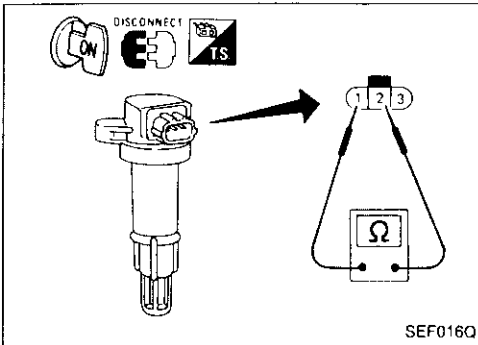

1. Disconnect ignition coil harness connector.
2. Check resistance between terminals ① and ②.

**Resistance: Approximately 1Ω**

If NG, replace ignition coil.

#### POWER TRANSISTOR

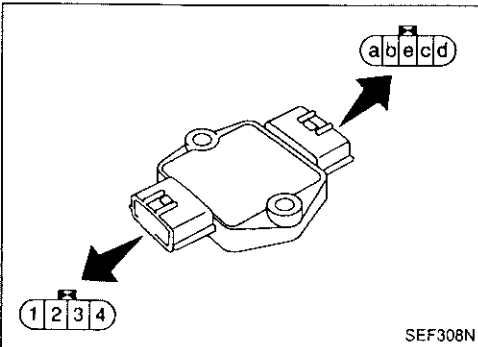

1. Disconnect power transistor harness connector.
2. Check power transistor continuity between terminals with analog tester as shown in the figure.

Terminal combination				Tester polarity	Continuity	Tester polarity	Continuity
e	e	e	e	⊕	No	⊖	Yes
1	2	3	4	⊖		⊕	
e	e	e	e	⊕	Yes	⊖	Yes
a	b	c	d	⊖		⊕	
1	2	3	4	⊕	Yes	⊖	No
a	b	c	d	⊖		⊕	

If NG, replace power transistor.

#### FUEL PUMP

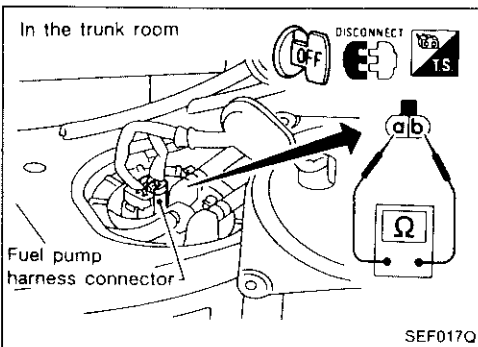

1. Disconnect fuel pump harness connector.
2. Check resistance between terminals ① and ②.

**Resistance: Approximately 0.2 - 5.0Ω**

If NG, replace fuel pump.

#### VEHICLE SPEED SENSOR

1. Lock up rear wheels. Use stands to support front

## TROUBLE DIAGNOSES

### Electrical Components Inspection (Cont'd) EGR AND CANISTER CONTROL SOLENOID VALVE

Check air passage continuity.

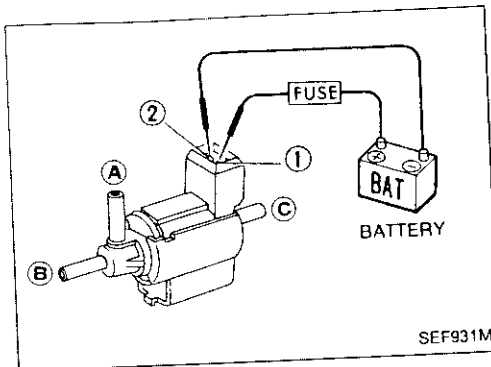

Condition	Air passage continuity between (A) and (B)	Air passage continuity between (A) and (C)
12V direct current supply between terminals ① and ②	Yes	No
No supply	No	Yes

### EGR VALVE

Apply vacuum to EGR vacuum port with a hand vacuum pump.  
**EGR valve spring should lift.**  
If NG, replace EGR valve.

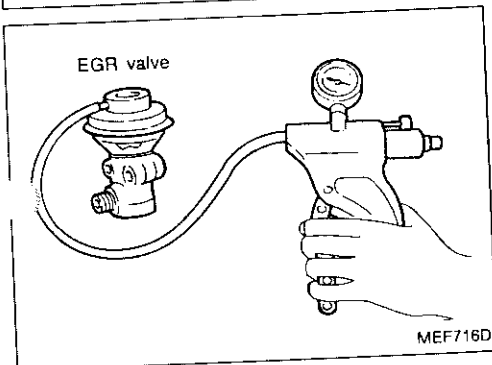

### EGRC-BPT VALVE

Plug one of two ports of EGRC-BPT valve.  
Apply a pressure above 0.490 kPa (4.90 mbar, 50 mmH<sub>2</sub>O, 1.97 inH<sub>2</sub>O) to check for leakage. If a leak is noted, replace valve.

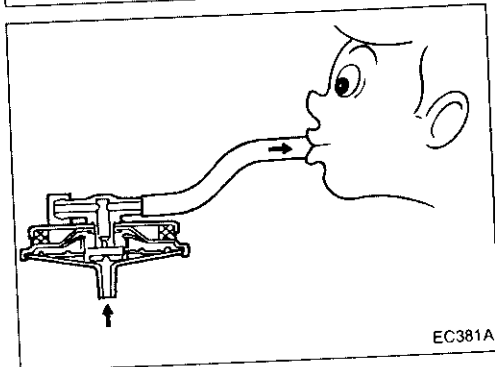

### HEATED OXYGEN SENSOR HEATER

Check resistance between terminals (a) and (c).  
**Resistance: 3 - 1,000Ω**  
If NG, replace heated oxygen sensor.

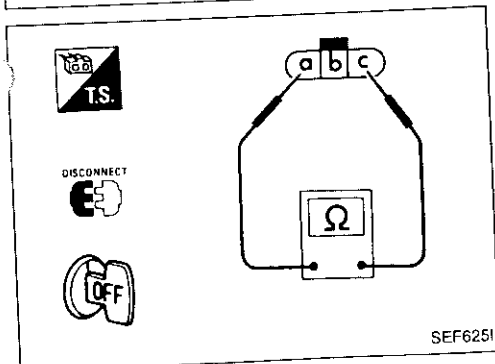

### THROTTLE POSITION SWITCH (A/T model only)

Refer to "TROUBLE DIAGNOSES" in AT section.

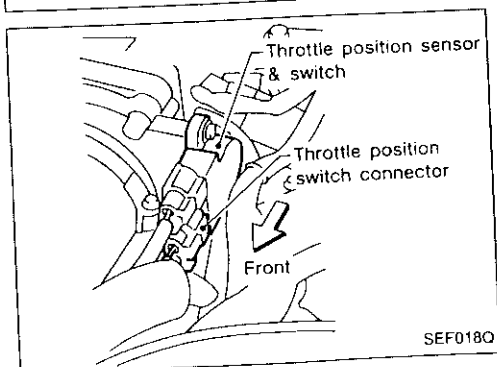

## TROUBLE DIAGNOSES

### Electrical Components Inspection (Cont'd)

#### THROTTLE POSITION SENSOR



1. Disconnect throttle position sensor harness connector.
2. Make sure that resistance between terminals **(b)** and **(c)** changes when opening throttle valve manually.

Accelerator pedal condition	Resistance kΩ
Completely released	Approximately 0.7
Partially released	0.7 - 5
Completely depressed	Approximately 5

If NG, replace throttle position sensor.

#### Adjustment of throttle position sensor (idle position)

If throttle position sensor is replaced or removed, it is necessary to install it in the proper position, by following the procedure as shown below:

1. Install throttle position sensor body in throttle body. Do not tighten bolts. Leave bolts loose.
2. Connect throttle position sensor harness connector.
3. Start engine and warm it up sufficiently.
4.  Perform "THROTTLE SEN ADJ" or "THRTL POS SEN ADJ" in "WORK SUPPORT" mode.
4.  Measure output voltage of throttle position sensor using voltmeter.

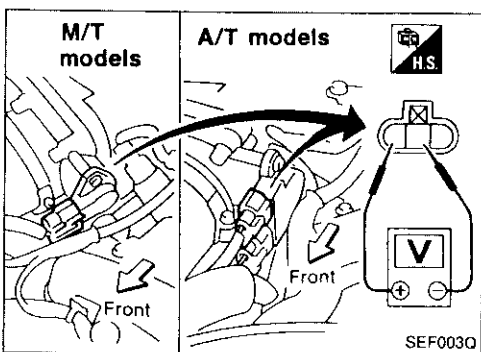
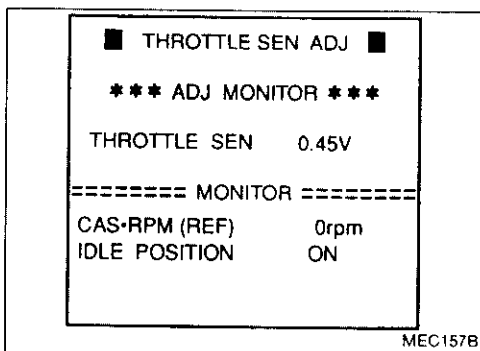
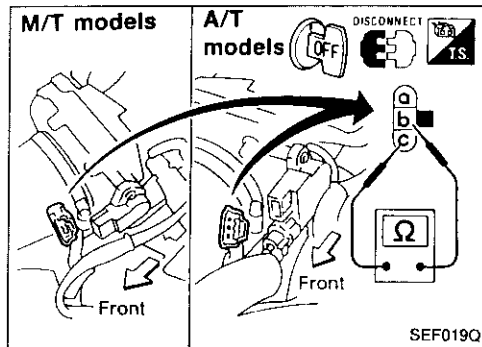

5. Adjust by rotating throttle position sensor body so that output voltage is 0.35 to 0.65V.
6. Tighten mounting bolts.
7. Disconnect throttle position sensor harness connector for a few seconds and then reconnect it.

#### IACV-AAC VALVE

- Check IACV-AAC valve resistance.  
**Resistance:**  
**Approximately 10Ω**
- Check plunger for seizing or sticking.
- Check for broken spring.

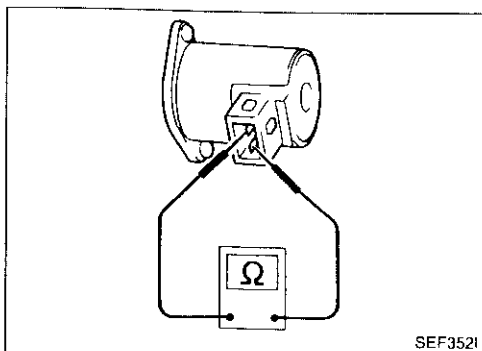

## TROUBLE DIAGNOSES

### Electrical Components Inspection (Cont'd)

#### IACV-FICD SOLENOID VALVE

Disconnect IACV-FICD solenoid valve harness connector.

- Check for clicking sound when applying 12V direct current to terminals.

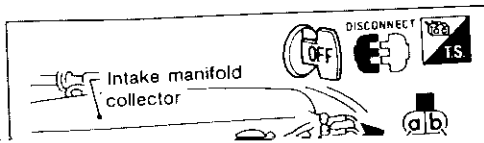

## TROUBLE DIAGNOSES

### Electrical Components Inspection (Cont'd) BOOST PRESSURE SENSOR

Check resistance between terminals.

Resistance:

- Ⓐ and Ⓑ Approximately 1.1 kΩ
- Ⓑ and Ⓒ Approximately 0.5 kΩ
- Ⓐ and Ⓒ Approximately 0.3 kΩ

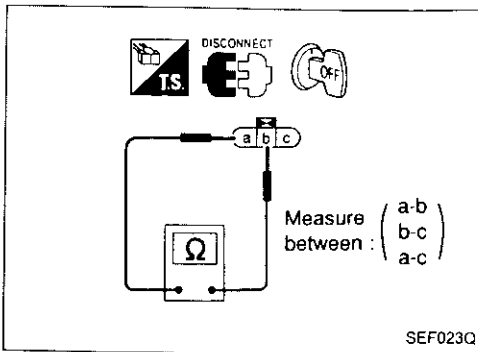

### POWER STEERING OIL PRESSURE SWITCH

1. Disconnect power steering oil pressure switch harness connector.
2. Check continuity between terminals.

Conditions	Continuity
Steering wheel is being turned	Yes
Steering wheel is not being turned	No

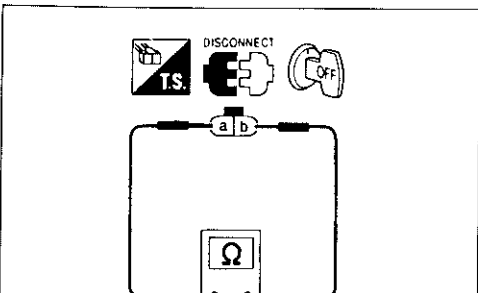

### COOLING FAN MOTOR

1. Disconnect cooling fan motor harness connector.
2. Supply cooling fan motor terminals with battery voltage and check operation.

Fan speed	Terminal	
	⊕	⊖
Low	Ⓐ	Ⓓ
High	Ⓐ, Ⓑ	Ⓒ, Ⓓ

Cooling fan motor should operate.

If NG, replace cooling fan motor.

### ECCS RELAY, FUEL PUMP RELAY, IGNITION COIL RELAY AND COOLING FAN RELAY 1-2

Check continuity between terminals ③ and ④.

Conditions	Continuity
12V direct current supply between terminals ① and ②	Yes
No current supply	No

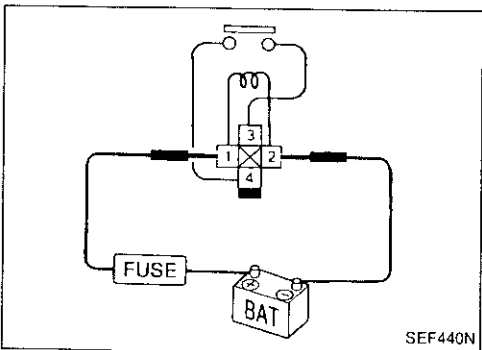
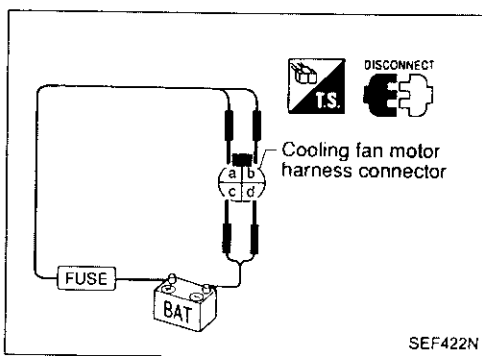

### RECIRCULATION VALVE

Check air passage continuity between Ⓐ and Ⓑ.

Condition	Continuity
A vacuum of above -27.3 to -34.0 kPa (-273 to -340 mbar, -205 to -255 mmHg, -8.07 to -10.04 inHg) is applied to vacuum port	Yes
No vacuum applied	No

If NG, replace recirculation valve.

Do not disassemble and adjust recirculation valve.

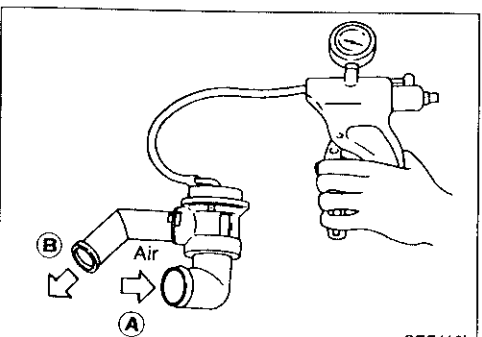

## TROUBLE DIAGNOSES

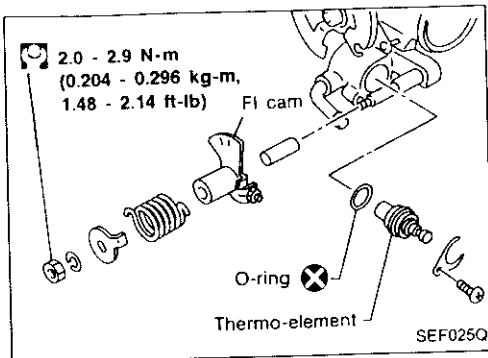

### Fast Idle Cam (FIC) Inspection and Adjustment REMOVAL AND INSTALLATION

- Do not extract thermo-element by pulling center rod.
- Always replace O-ring with a new one.
- Lubricate O-ring with a smear of engine oil.
- After installation, check for water leakage.

GI

VA

EM

LC

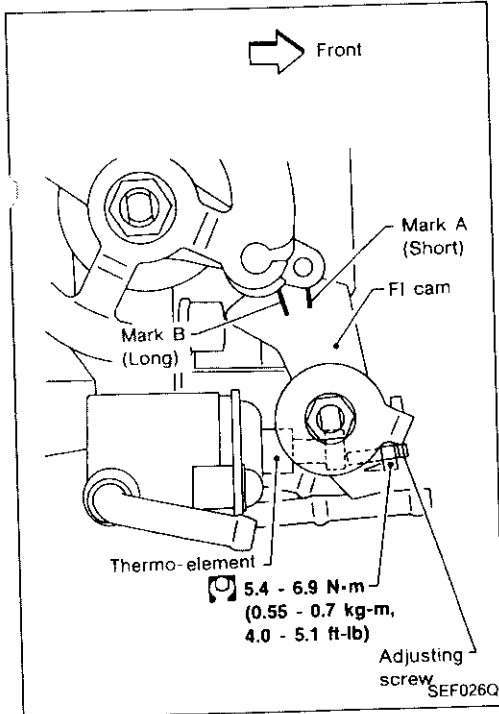

### INSPECTION

1. Start engine. Warm the engine coolant up to 80°C (176°F) and keep it there for 10 minutes.
2. Check that mark A (short line) on FI cam aligns with roller center.
- a. If NG, measure thermo-element stroke (L) and engine coolant temperature. If stroke L is in the specification shown in the figure, adjust FI cam with adjusting screw.
- b. If stroke (L) is out of the specification, replace thermo-element with a new one.

EC

FE

CL

WT

AT

### ADJUSTMENT

1. Start engine. Warm the engine coolant up to 80°C (176°F) and keep it there for 10 minutes.
2. Loosen adjusting screw and align mark A (short line) on FI cam with roller center. Tighten lock nut to the specification.
3. Cool down the engine coolant to 25°C (77°F) and keep it there for 5 minutes.
4. Check that mark B (long line) on FI cam aligns with roller center.

PD

FA

RA

BR

ST

RS

BT

HA

EL

DX

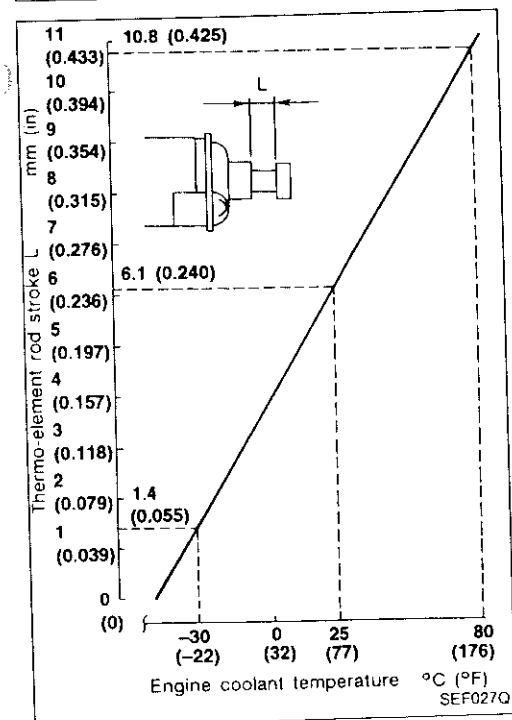

## MULTIPOINT FUEL INJECTION SYSTEM INSPECTION

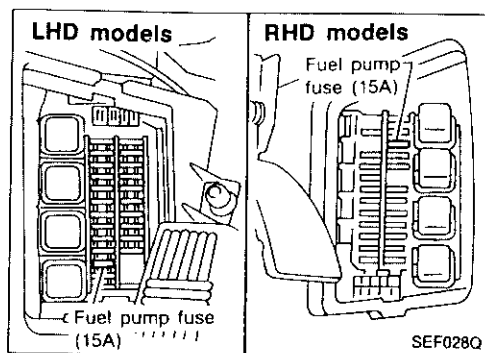
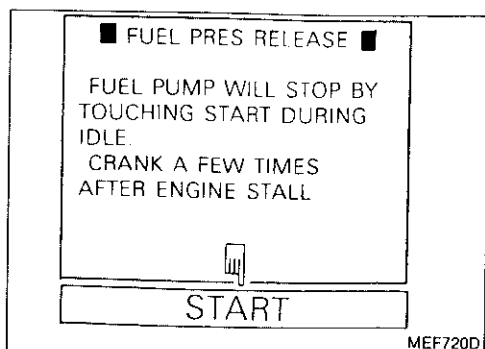

### Releasing Fuel Pressure

Before disconnecting fuel line, release fuel pressure from fuel line to eliminate danger.

- ① Perform "FUEL PRESSURE RELEASE" in "WORK SUPPORT" mode with CONSULT.

- ⓧ 1. Remove fuse for fuel pump.
- 2. Start engine.
- 3. After engine stalls, crank it two or three times to release all fuel pressure.
- 4. Turn ignition switch off and reconnect fuse for fuel pump.

### Fuel Pressure Check

- a. Make sure that clamp screw does not contact adjacent parts.
- b. Use a torque driver to tighten clamps.
- c. Use Pressure Gauge to check fuel pressure.
- d. Do not perform fuel pressure check while fuel pressure regulator control system is operating; otherwise, fuel pressure gauge might indicate incorrect readings.
  1. Release fuel pressure to zero.
  2. Disconnect fuel hose between fuel filter and fuel tube (engine side).
  3. Install pressure gauge between fuel filter and fuel tube.
  4. Start engine and check for fuel leakage.

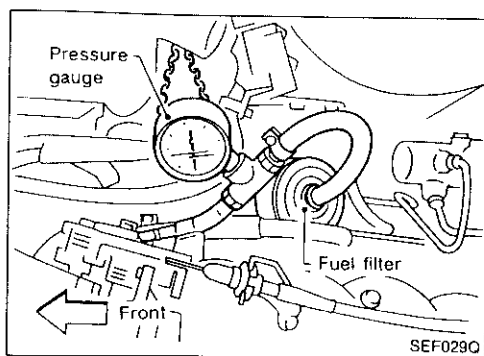

- 5. Read the indication of fuel pressure gauge.

#### At idling:

When fuel pressure regulator valve vacuum hose is connected.

Approximately 245 kPa (2.45 bar, 2.5 kg/cm<sup>2</sup>, 36 psi)

When fuel pressure regulator valve vacuum hose is disconnected.

Approximately 294.1 kPa (2.94 bar, 3.0 kg/cm<sup>2</sup>, 43 psi)

## MULTIPOINT FUEL INJECTION SYSTEM INSPECTION

### Fuel Pressure Check (Cont'd)

6. Stop engine and disconnect fuel pressure regulator vacuum hose from intake manifold.
7. Plug intake manifold with a rubber cap.
8. Connect variable vacuum source to fuel pressure regulator.

GI

MA

EM

LC

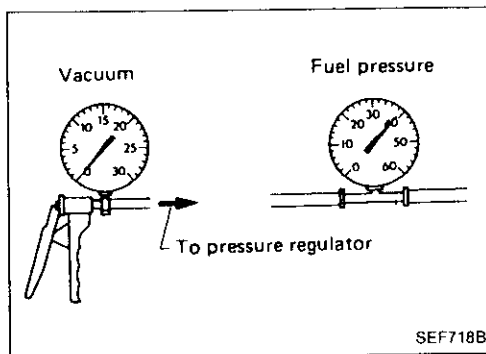

9. Start engine and read indication of fuel pressure gauge as vacuum is changed.

**Fuel pressure should decrease as vacuum increases. If results are unsatisfactory, replace fuel pressure regulator.**

EC

FE

CL

MT

### Injector Removal and Installation

1. Remove injectors with fuel tube assembly. Refer to "INTAKE MANIFOLD" in EM section.
2. Push out any malfunctioning injector from fuel tube assembly.
  - Do not extract injector by pinching connector.
  - Always replace O-rings and insulators with new ones.
  - Lubricate O-ring with a smear of silicone oil.
3. Installation is in the reverse order of removal.

AT

PD

FA

#### CAUTION:

**After properly connecting injectors to fuel tube assembly, check connections for fuel leakage.**

RA

BR

ST

RS

BT

HA

EL

DX

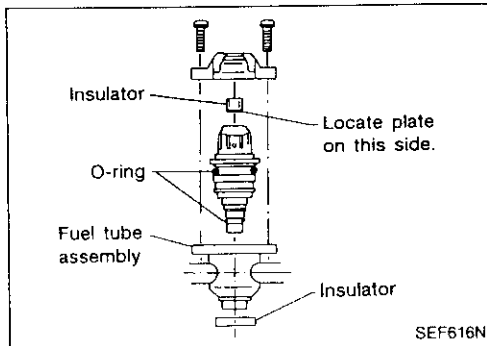



# EVAPORATIVE EMISSION SYSTEM

## Description

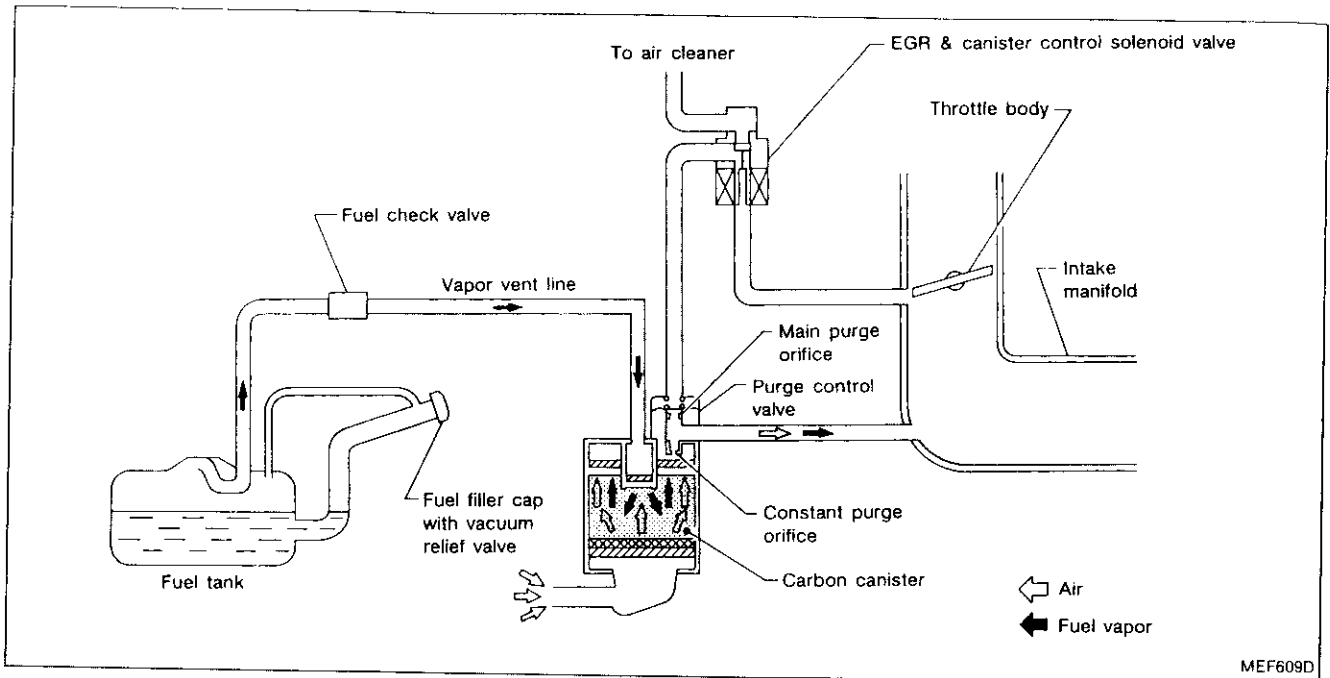

The evaporative emission system is used to reduce hydrocarbons emitted into the atmosphere from the fuel system. This reduction of hydrocarbons is accomplished by activated charcoals in the carbon canister.

The fuel vapor from sealed fuel tank is led into the canister when the engine is off. The fuel vapor is then stored in the canister. The canister retains the fuel vapor until the canister is purged by air.

When the engine is running, the air is drawn through the bottom of the canister. The fuel vapor will then be led to the intake manifold.

When the engine runs at idle, the purge control valve is closed. Only a small amount of vapor flows into the intake manifold through the constant purge orifice.

As the engine speed increases and the throttle vacuum rises, the purge control valve opens. The vapor is sucked through both main purge and constant purge orifices.

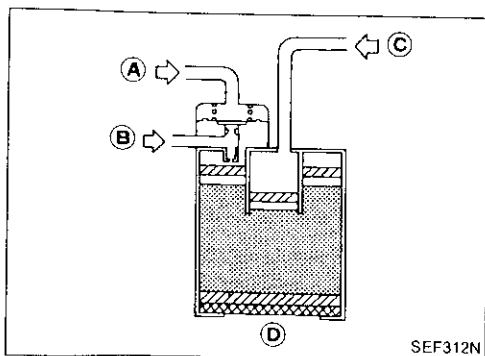

## Inspection

### ACTIVATED CARBON CANISTER

Check carbon canister as follows:

1. Blow air in port (A) and ensure that there is no leakage.
2.
  - Apply vacuum to port (A).
  - Cover port (B) with hand.
  - Blow air in port (C) and ensure free flow out of port (B).

## EVAPORATIVE EMISSION SYSTEM

### Inspection (Cont'd)

#### FUEL TANK VACUUM RELIEF VALVE

1. Wipe clean valve housing.
2. Suck air through the cap. A slight resistance accompanied by valve clicks indicates that valve is in good mechanical condition. Note also that, by further sucking air, the resistance should disappear with valve clicks.
3. If valve is clogged or if no resistance is felt, replace cap as an assembly.

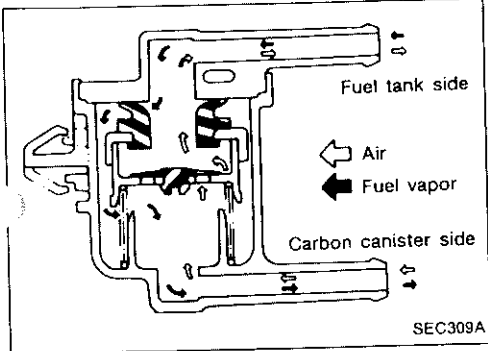
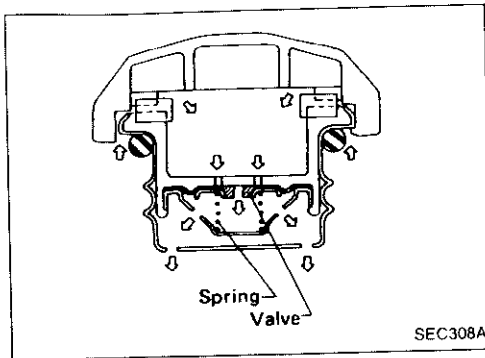

#### FUEL CHECK VALVE

1. Blow air through connector on fuel tank side. A considerable resistance should be felt and a portion of air flow should be directed toward the canister.
2. Blow air through connector on canister side. Air flow should be smoothly directed toward fuel tank.
3. If fuel check valve is suspected of not properly functioning in steps 1 and 2 above, replace it.

GI

MA

EM

LC

EC

FE

CL

MT

AT

PD

FA

RA

BR

ST

RS

BT

HA

EL

IDX

# CRANKCASE EMISSION CONTROL SYSTEM

## Description

This system returns blow-by gas to the intake collector.

The positive crankcase ventilation (PCV) valve is provided to conduct crankcase blow-by gas to the intake manifold.

During partial throttle operation of the engine, the intake manifold sucks the blow-by gas through the PCV valve.

Normally, the capacity of the valve is sufficient to handle any blow-by and a small amount of ventilating air.

The ventilating air is then drawn from air inlet tubes into crankcase through a hose. The hose connects the air inlet tubes and the rocker cover. Under full-throttle condition, the manifold vacuum is insufficient to draw the blow-by flow through the valve. Flow then goes through the hose connection in the reverse direction.

Under any condition, some of the flow goes through the hose connection to the air inlet tubes. This will occur on vehicles with an excessively high blow-by.

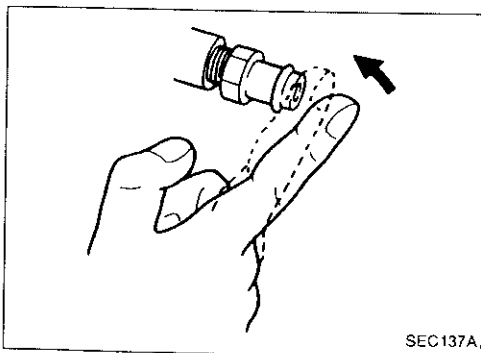
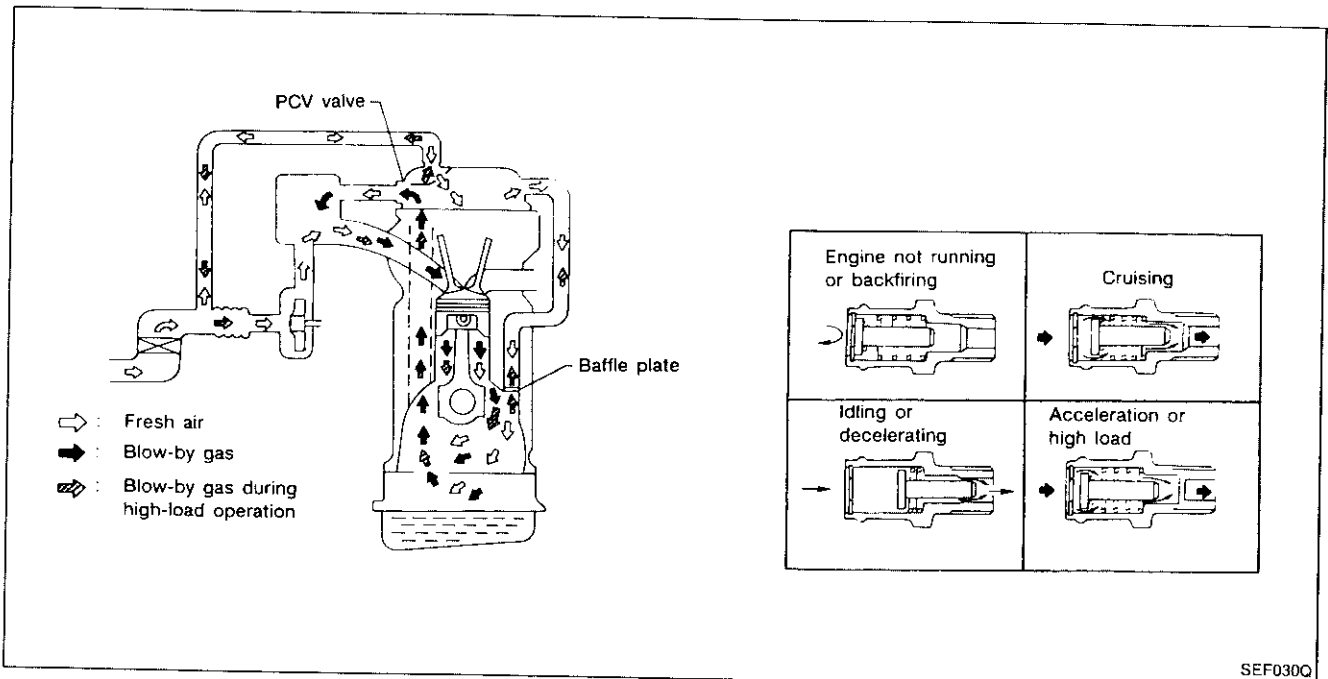

## Inspection

### PCV (Positive Crankcase Ventilation) VALVE

With engine running at idle, remove ventilation hose from PCV valve; if the valve is working properly, a hissing noise will be heard as air passes through it and a strong vacuum should be felt immediately when a finger is placed over valve inlet.

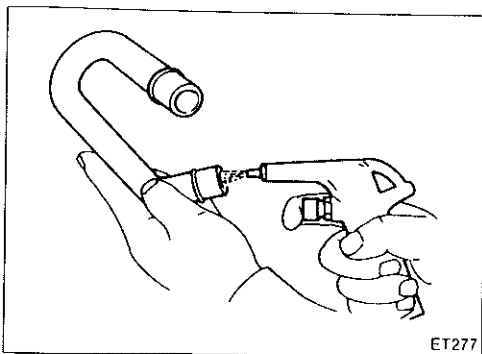

### VENTILATION HOSE

1. Check hoses and hose connections for leaks.
2. Disconnect all hoses and clean with compressed air. If any hose cannot be freed of obstructions, replace.

# SERVICE DATA AND SPECIFICATIONS (SDS)

## General Specifications

PRESSURE REGULATOR	
Fuel pressure at idling kPa (bar, kg/cm <sup>2</sup> , psi)	Approximately 245 (2.45, 2.5, 36)
Vacuum hose is connected	
Vacuum hose is disconnected	Approximately 294 (2.94, 3.0, 43)

## Inspection and Adjustment

Idle speed*1	rpm	
No-load*2		800 ± 50
M/T & A/T (in "N" position)		
Air conditioner: ON		800 ± 50
M/T & A/T (in "N" position)		
Ignition timing		15° ± 2° BTDC
Throttle position sensor idle position	V	0.35 - 0.65

\*1: Feedback controlled and needs no adjustments

\*2: Under the following conditions:

- Air conditioner switch: OFF
- Steering wheel: Kept straight
- Electric load: OFF (Lights, heater, fan & rear defogger)
- Cooling fan: OFF

### IGNITION COIL

Primary voltage	V	12
Primary resistance [at 20°C (68°F)]	Ω	Approximately 1

### ENGINE COOLANT TEMPERATURE SENSOR

Temperature °C (°F)	Resistance kΩ
20 (68)	2.1 - 2.9
50 (122)	0.68 - 1.00
80 (176)	0.30 - 0.33

### FUEL PUMP

Resistance	Ω	0.2 - 5.0
------------	---	-----------

### HEATED OXYGEN SENSOR HEATER

Resistance	Ω	3 - 1,000
------------	---	-----------

### IACV-AAC VALVE

Resistance	Ω	Approximately 10
------------	---	------------------

### INJECTOR

Resistance	Ω	10 - 14
------------	---	---------

### THROTTLE POSITION SENSOR

Accelerator pedal conditions	Resistance kΩ
Completely released	Approximately 0.7
Partially released	0.7 - 5
Completely depressed	Approximately 5

# ACCELERATOR CONTROL, FUEL & EXHAUST SYSTEMS

## SECTION **FE**

GI

MA

EM

LC

EC

**FE**

CL

MT

AT

PD

FA

RA

BR

ST

RS

BT

HA

EL

IDX

## CONTENTS

<b>PREPARATION/ACCELERATOR CONTROL SYSTEM</b> .....	2
Special Service Tool .....	2
Accelerator Control System .....	2
Adjusting Accelerator Wire .....	2

<b>FUEL SYSTEM</b> .....	3
Fuel Tank .....	3
Fuel Pump and Gauge .....	5
<b>EXHAUST SYSTEM</b> .....	7

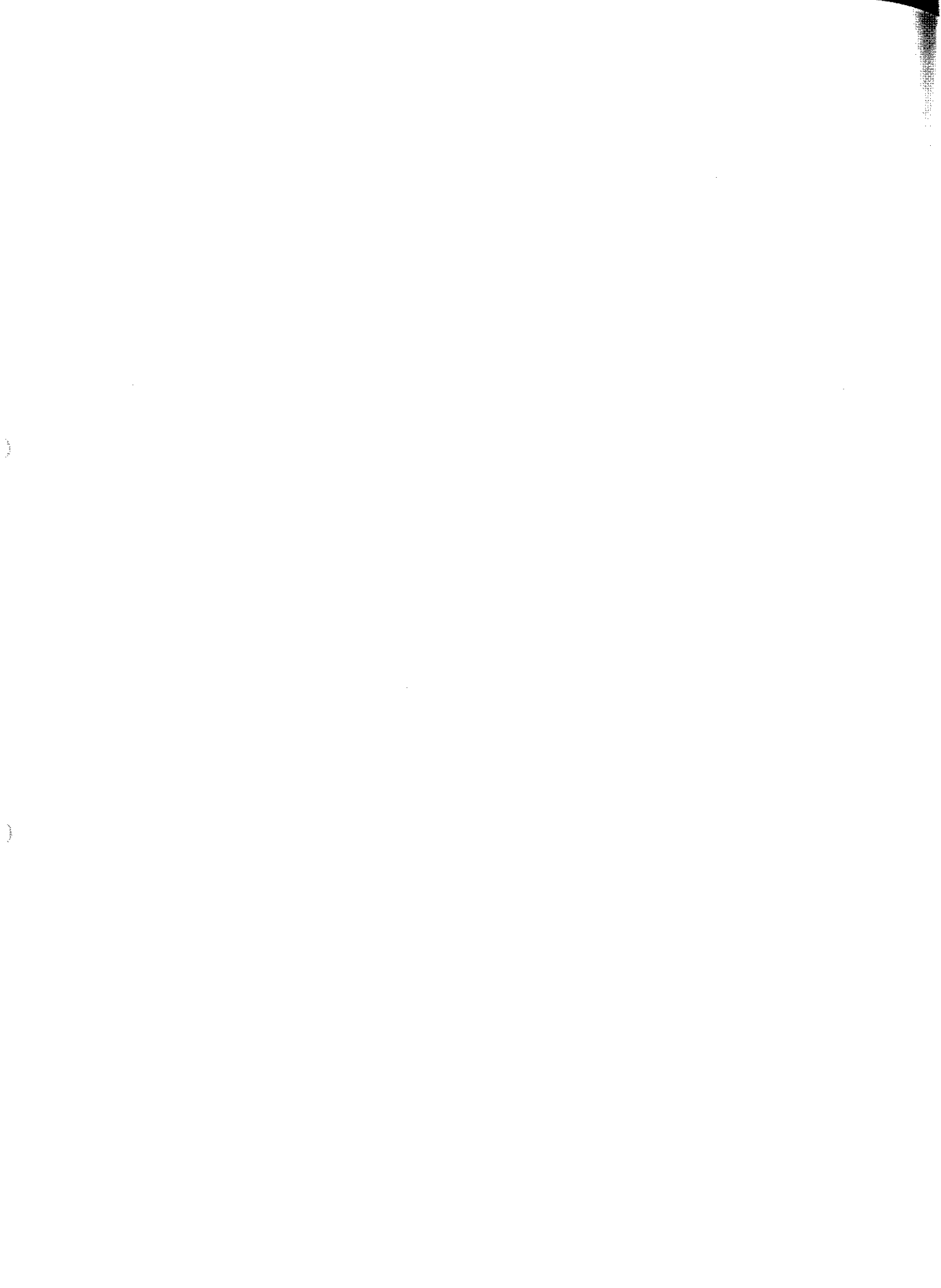

## PREPARATION/ACCELERATOR CONTROL SYSTEM

### Special Service Tool

Tool number Tool name	Description
KV999G0010 Fuel tank lock ring socket	Removing and installing fuel tank lock ring
	
	NT057

### Accelerator Control System

#### CAUTION:

- When removing accelerator wire, make a mark to indicate lock nut's initial position.
- Check that throttle valve opens fully when accelerator pedal is fully depressed. Also check that it returns to idle position when pedal is released.
- Check accelerator control parts for improper contact with any adjacent parts.
- When connecting accelerator wire, be careful not to twist or scratch wire.
- Refer to "AUTOMATIC SPEED CONTROL DEVICE" in EL section for ASCD wire adjustment.
- Refer to "ON-VEHICLE SERVICE" in AT section for Kickdown switch adjustment.

SEC. 180

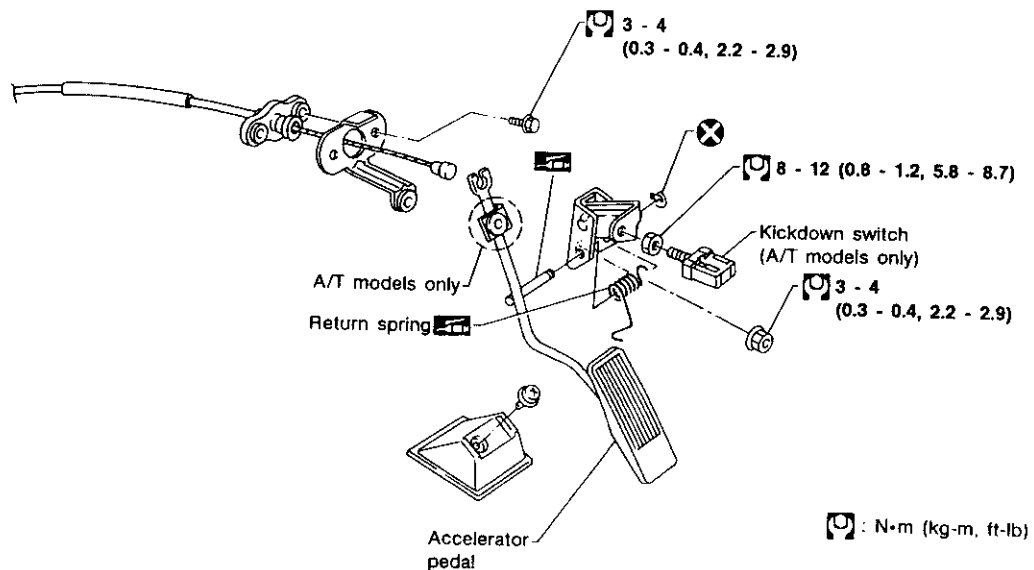

SFE363A

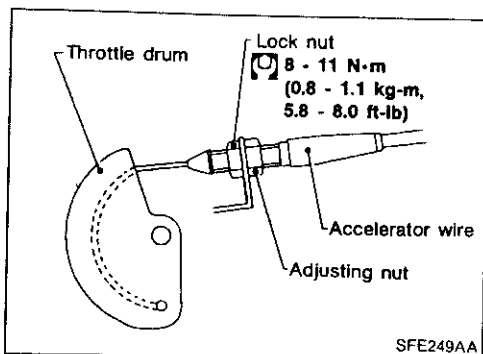

### Adjusting Accelerator Wire

1. Loosen lock nut, and tighten adjusting nut until throttle drum starts to move.
2. From that position turn back adjusting nut 1.5 to 2 turns, and secure lock nut.

# FUEL SYSTEM

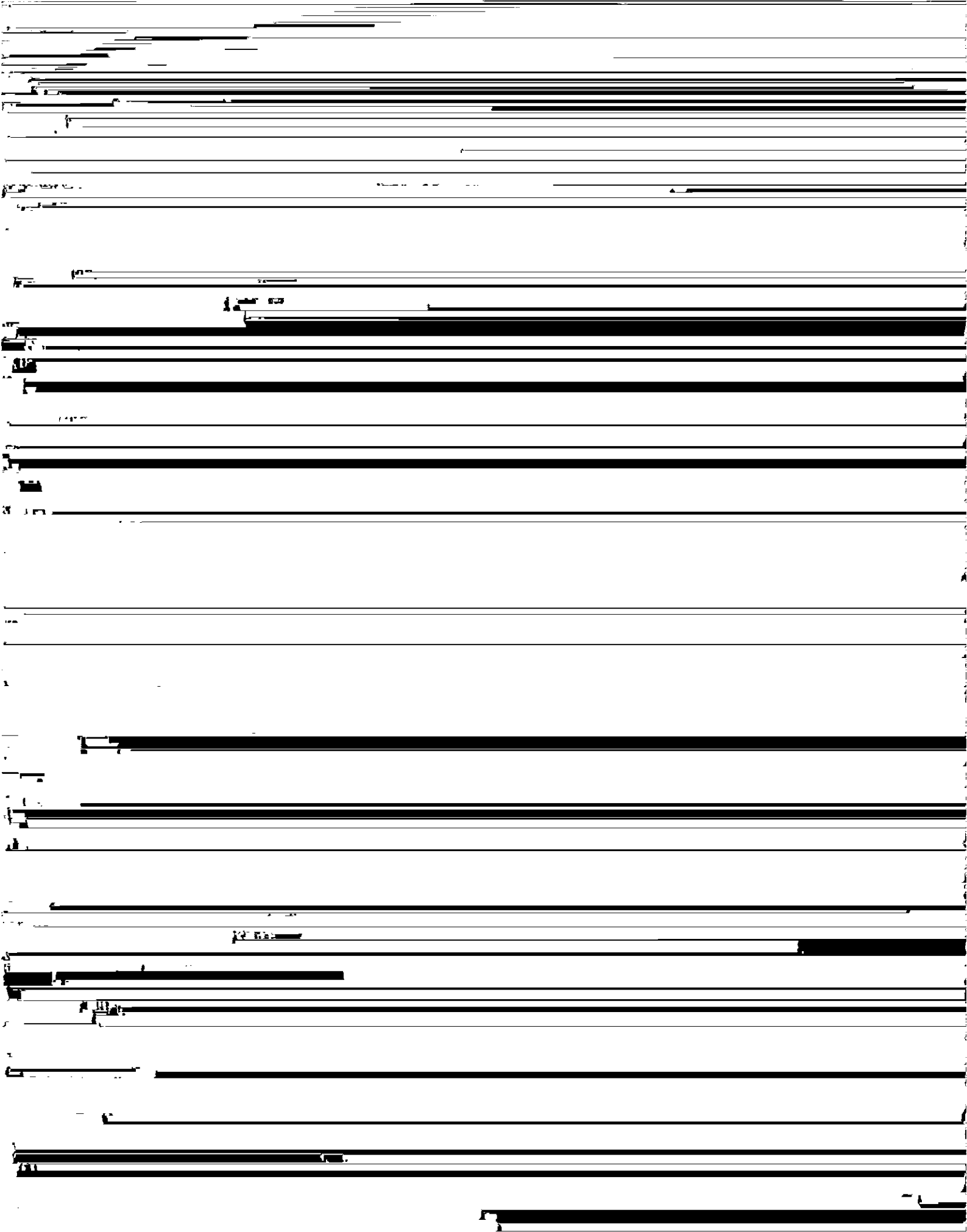



## FUEL SYSTEM

### Fuel Tank (Cont'd)

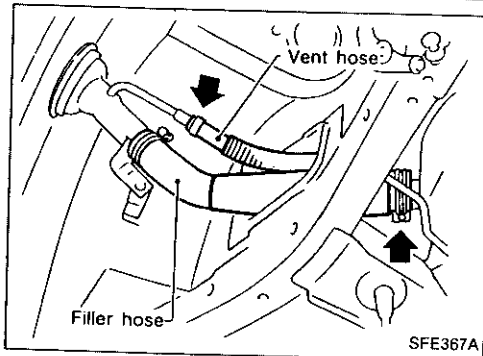
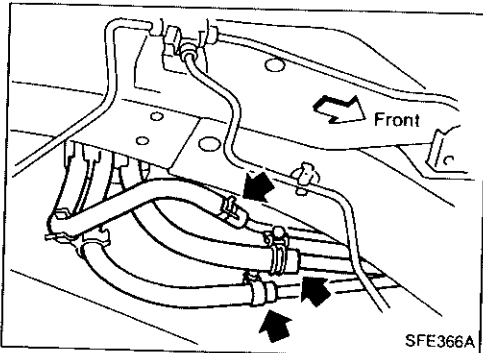
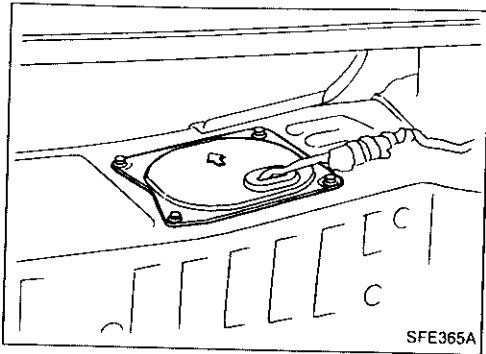

1. Release fuel pressure from fuel line.  
Refer to "Changing Fuel Filter" in MA section.
2. Remove inspection hole cover located behind the rear seat.
3. Disconnect harness connectors under inspection hole cover.
4. Disconnect fuel tubes located on the lower right-hand side of fuel tank.
  - Put mating marks on tubes for correct installation.
5. Remove exhaust center tube, propeller shaft, differential carrier, rear suspension member and drive shafts (Refer to RA section).
6. Disconnect filler hose at fuel tank side and vent hose at filler tube side.
7. Remove fuel tank protector.
8. Remove fuel tank band mounting bolts while supporting fuel tank.
9. Remove fuel tank.



## INSTALLATION

## FUEL SYSTEM

### Fuel Tank (Cont'd)

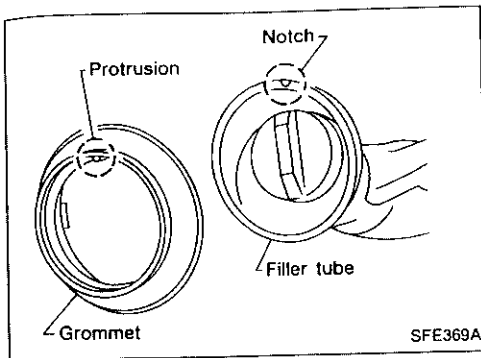

- When installing the grommet of the filler tube, align the protrusion on the grommet with the notch on the filler tube.

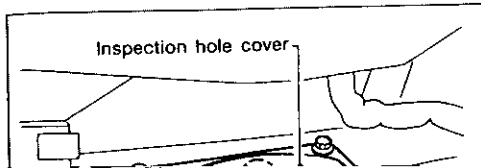

- When installing the inspection hole, put the arrow mark forward.

GI

MA

EM

LC

EC

EE

## FUEL SYSTEM

### Fuel Pump and Gauge (Cont'd)

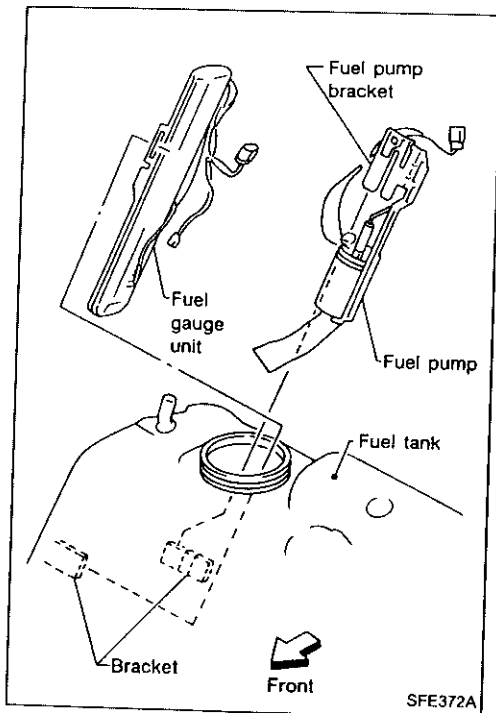

6. Remove fuel pump pulling the top end of the fuel pump bracket upward.
7. Remove fuel gauge unit.
  - a. Pull fuel gauge unit horizontally to the left.

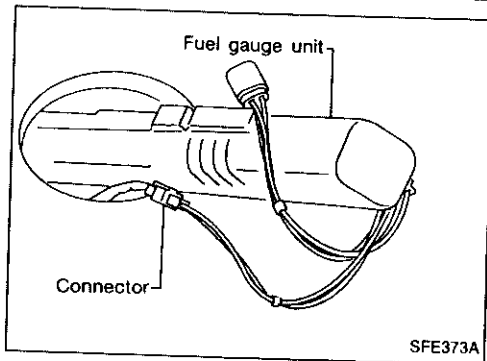

- b. Remove harness connector.
  - Carefully place the removed connector in the fuel tank so that it can be pulled out for the installation.

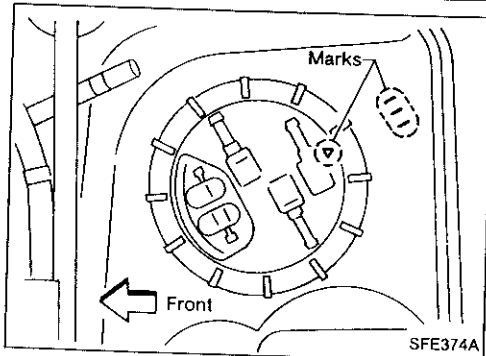

### INSTALLATION

Installation procedure is the reverse order of removal.

#### CAUTION:

- When installing upper plate, align the mark on it with the center of marks on fuel tank.

# EXHAUST SYSTEM

## CAUTION:

- Always replace exhaust gaskets with new ones when reassembling.
- With engine running, check all tube connections for exhaust gas leaks, and entire system for unusual noises.
- After installation, check to ensure that mounting brackets and mounting insulator are free from undue stress. If not installed properly, excessive noise or vibration may be transmitted to the vehicle body.

SEC. 200

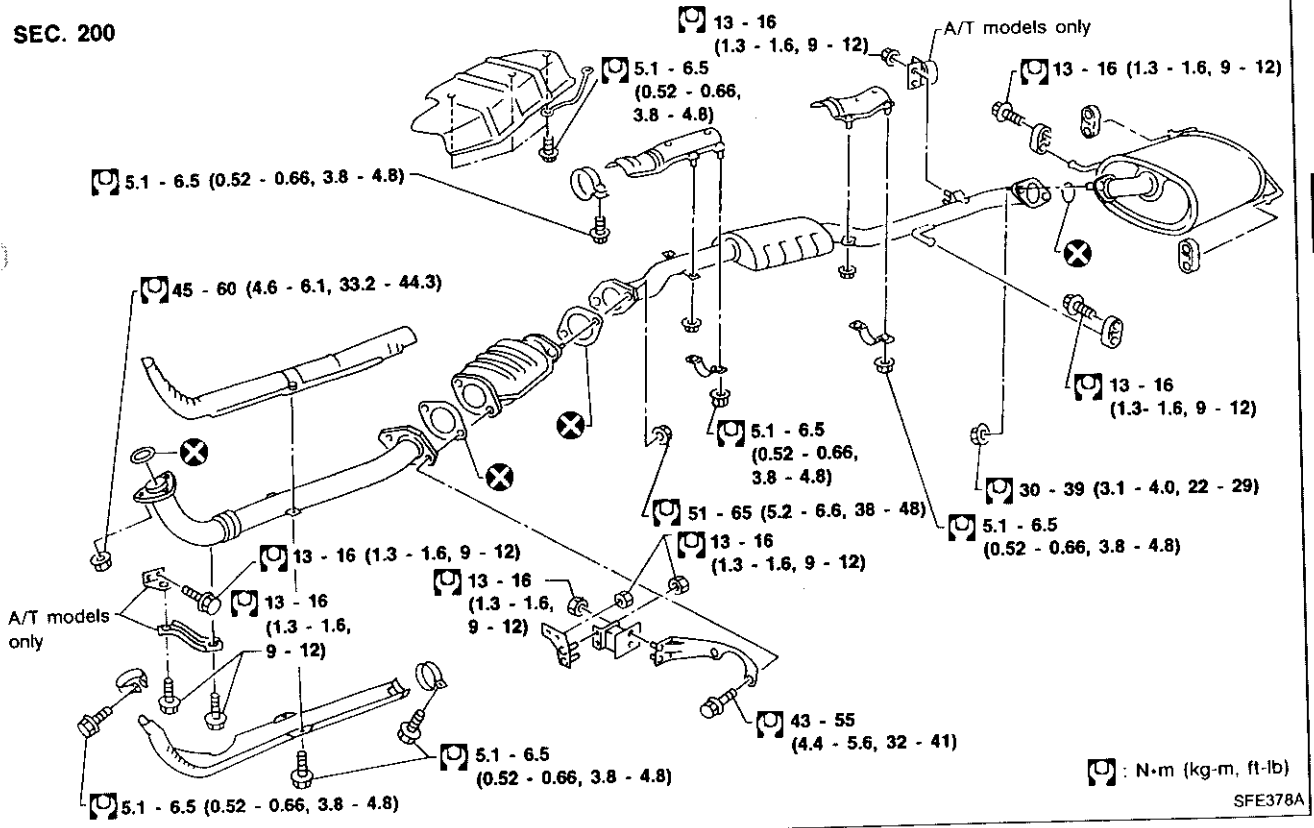

GI

MA

EM

LC

EC

FE

CL

MT

AT

PD

FA

RA

BR

ST

RS

BT

HA

EL

IDX

# CLUTCH

## SECTION

# CL

GI

VA

EM

LC

EC

FE

## CONTENTS

<b>PRECAUTIONS AND PREPARATION</b> .....	2	Clutch Master Cylinder.....	6	<b>CL</b>
Precautions.....	2	Operating Cylinder.....	7	
Special Service Tools.....	2	<b>CLUTCH RELEASE MECHANISM</b> .....	8	
Commercial Service Tools.....	2	<b>CLUTCH DISC AND CLUTCH COVER</b> .....	10	MT
<b>CLUTCH SYSTEM</b> .....	3	Clutch Cover and Flywheel.....	10	
<b>INSPECTION AND ADJUSTMENT</b> .....	4	Clutch Disc.....	11	AT
Adjusting Clutch Pedal.....	4	<b>SERVICE DATA AND SPECIFICATIONS (SDS)</b> .....	12	
Bleeding Procedure.....	5	General Specifications.....	12	
<b>HYDRAULIC CLUTCH CONTROL</b> .....	6	Inspection and Adjustment.....	12	FD

EA

RA

RR

ST

RS

BT

HA

EL

IDX



## PRECAUTIONS AND PREPARATION

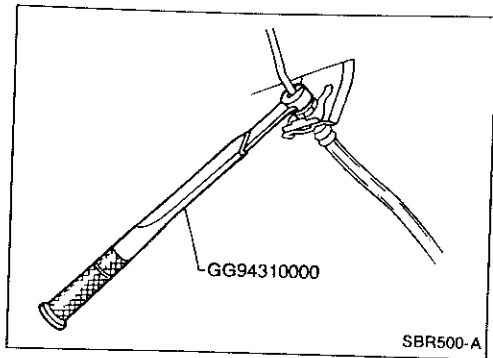

### Precautions

- Recommended fluid is brake fluid "DOT 3".
- Never reuse drained brake fluid.
- Be careful not to splash brake fluid on painted areas.
- When removing and installing clutch piping, use Tool.
- Use new brake fluid to clean or wash all parts of master cylinder, operating cylinder and clutch damper.
- Never use mineral oils such as gasoline or kerosene. It will ruin the rubber parts of the hydraulic system.

### WARNING:

After cleaning the clutch disc, wipe it with a dust collector. Do not use compressed air.

### Special Service Tools

Tool number Tool name	Description
GG94310000 Flare nut torque wrench	<p>NT406</p> <p>a: 10 mm (0.39 in)</p> <p>Removing and installing each clutch piping</p>
ST20600000 Clutch aligning bar	<p>NT405</p> <p>a: 15.9 mm (0.626 in) dia. b: 22.8 mm (0.898 in) dia. c: 55 mm (2.17 in)</p> <p>Installing clutch cover and clutch disc</p>
ST20050240 Diaphragm spring adjusting wrench	<p>NT404</p> <p>a: 150 mm (5.91 in) b: 25 mm (0.98 in)</p> <p>Adjusting unevenness of diaphragm spring of clutch cover</p>

### Commercial Service Tools

Tool name	Description
Bearing puller	<p>NT077</p> <p>Removing release bearing</p>
Bearing drift	<p>NT063</p> <p>a: 50 mm (1.97 in) dia.</p> <p>Installing release bearing</p>

# CLUTCH SYSTEM

SEC. 300-305-465

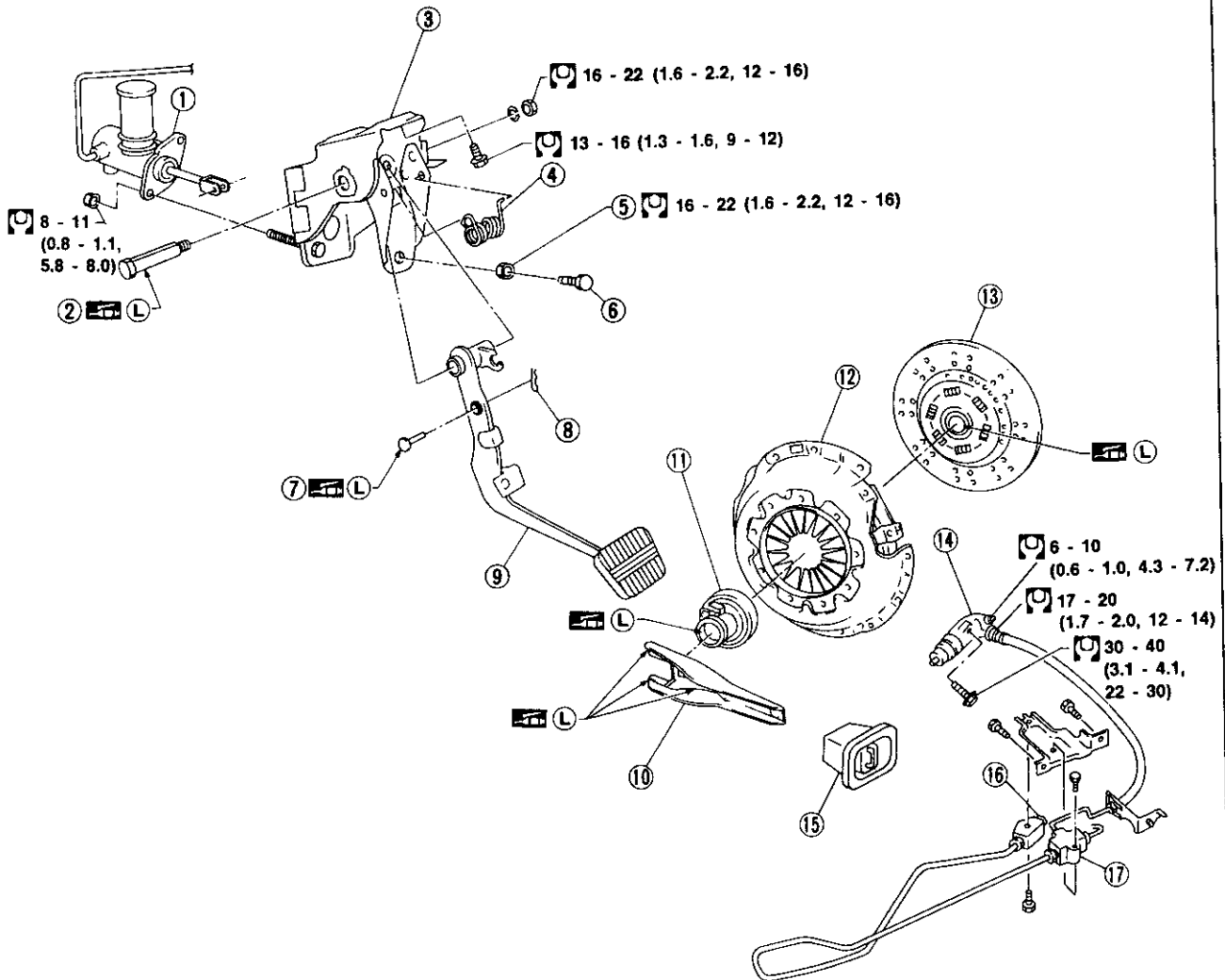

: N·m (kg·m, ft·lb)  
 L: Apply lithium-based grease including molybdenum disulphide.

SCL604

- ① Clutch master cylinder
- ② Fulcrum pin
- ③ Pedal bracket
- ④ Return spring
- ⑤ Lock nut
- ⑥ Lock nut

- ⑦ Clevis pin
- ⑧ Snap pin
- ⑨ Clutch pedal
- ⑩ Withdrawal lever
- ⑪ Release bearing
- ⑫ Clutch cover

- ⑬ Clutch disc
- ⑭ Operating cylinder
- ⑮ Dust cover
- ⑯ Bleeder screw
- ⑰ Clutch connector

GI  
 MA  
 EM  
 LC  
 EC  
 FE  
**CL**  
 MT  
 AT  
 PD  
 FA  
 RA  
 BR  
 ST  
 RS  
 BT  
 HA  
 EL  
 DX



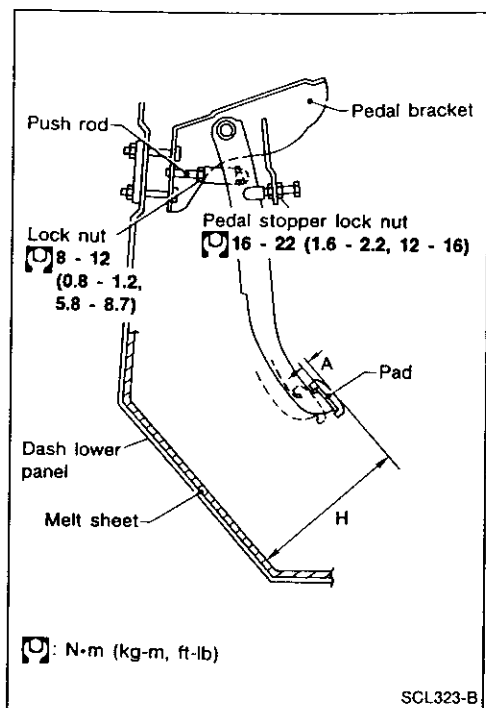

## Adjusting Clutch Pedal

1. Adjust pedal height with pedal stopper.

### Pedal height "H":

LHD 192 - 202 mm (7.56 - 7.95 in)

RHD 188 - 198 mm (7.40 - 7.80 in)

2. Adjust pedal free play with master cylinder push rod. Then tighten lock nut.

### Pedal free play "A":

9 - 16 mm (0.35 - 0.63 in)

Pedal free play means the following total measured at position of pedal pad:

- Play due to clevis pin and clevis pin hole in clutch pedal.
3. Make sure that clevis pin can be rotated smoothly. If not, readjust pedal free play with master cylinder push rod.

## INSPECTION AND ADJUSTMENT

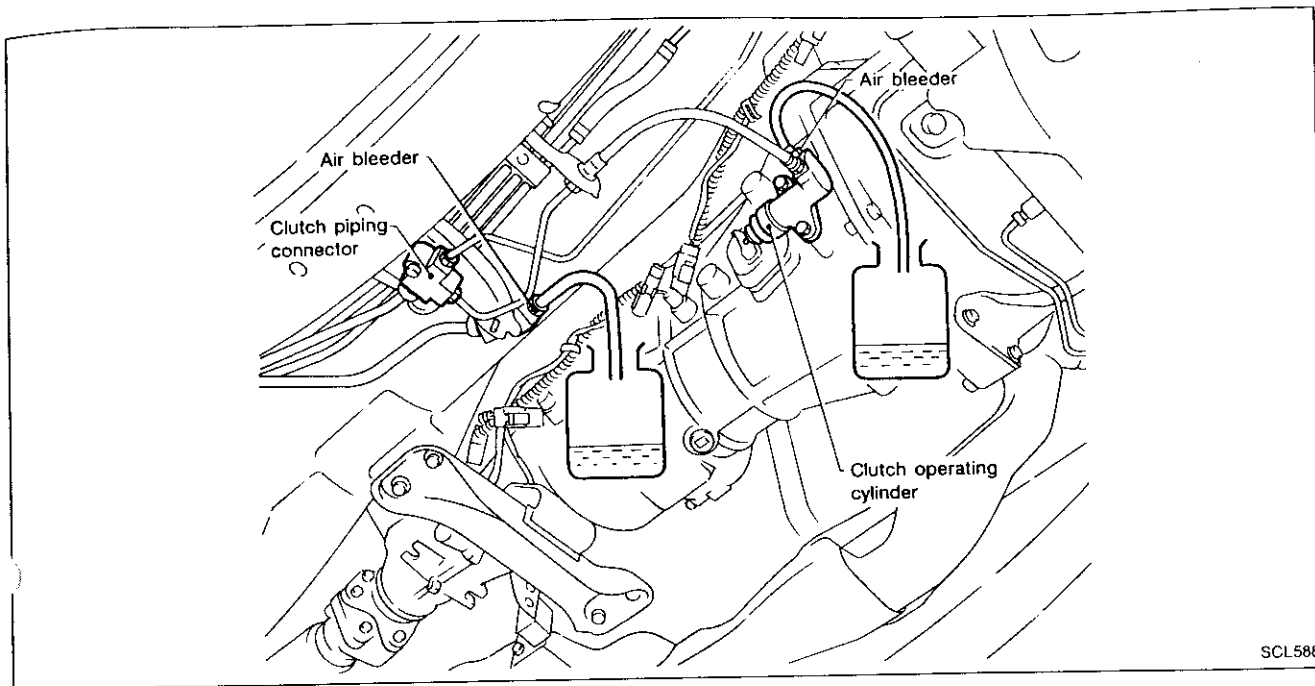

GI  
MA  
EM  
LC  
EC  
FE  
**CL**

### Bleeding Procedure

1. Bleed air from clutch master cylinder (RHD model only) according to the following procedure.

**Carefully monitor fluid level at master cylinder during bleeding operation.**

- a. Top up reservoir with recommended brake fluid.
  - b. Connect a transparent vinyl tube to air bleeder valve.
  - c. Fully depress clutch pedal several times.
  - d. With clutch pedal depressed, open bleeder valve to release air.
  - e. Close bleeder valve.
  - f. Repeat steps c through e above until brake fluid flows from air bleeder valve without air bubbles.
2. Bleed air from clutch operating cylinder according to the above same procedure.
  3. Bleed air from clutch piping connector according to the above same procedure.
  4. Repeat the above bleeding procedures 1 through 3 several times.

MT  
AT  
PD  
FA  
RA  
BR  
ST  
RS

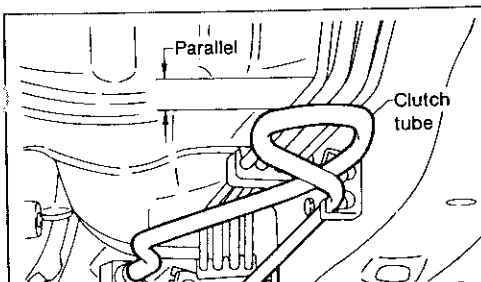

Remarks

parallel to body

# HYDRAULIC CLUTCH CONTROL

## Clutch Master Cylinder

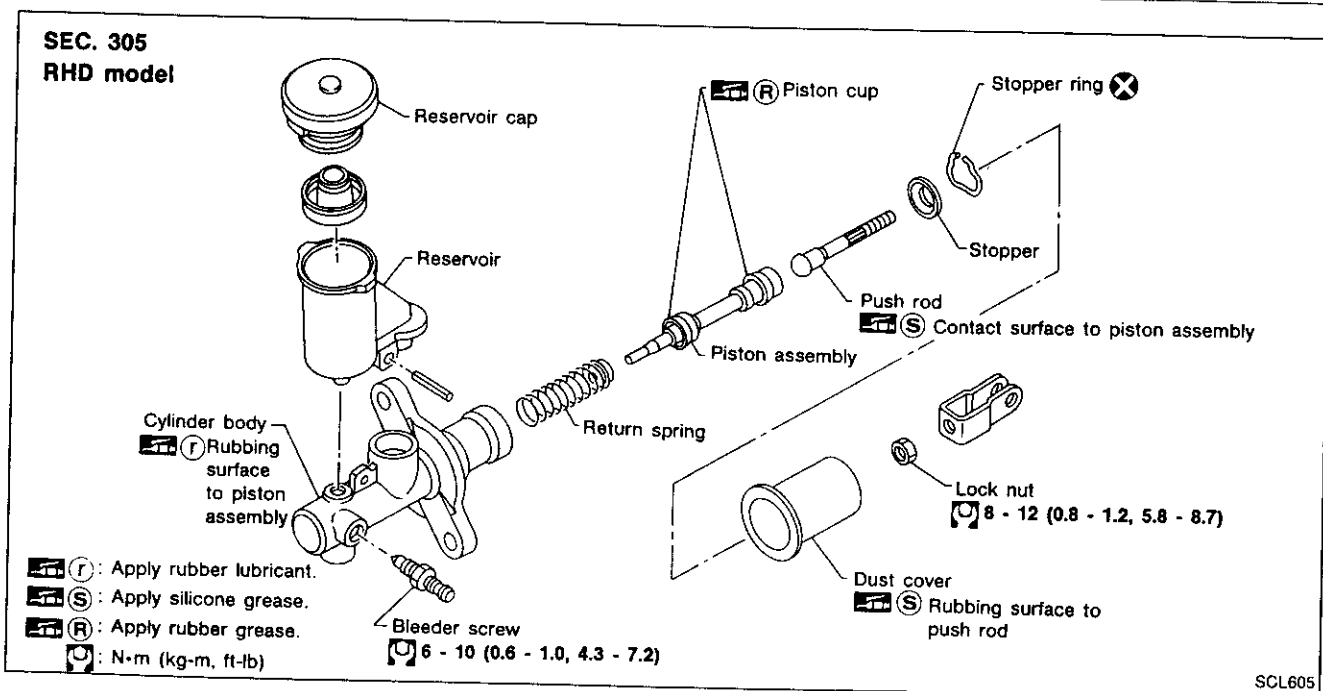
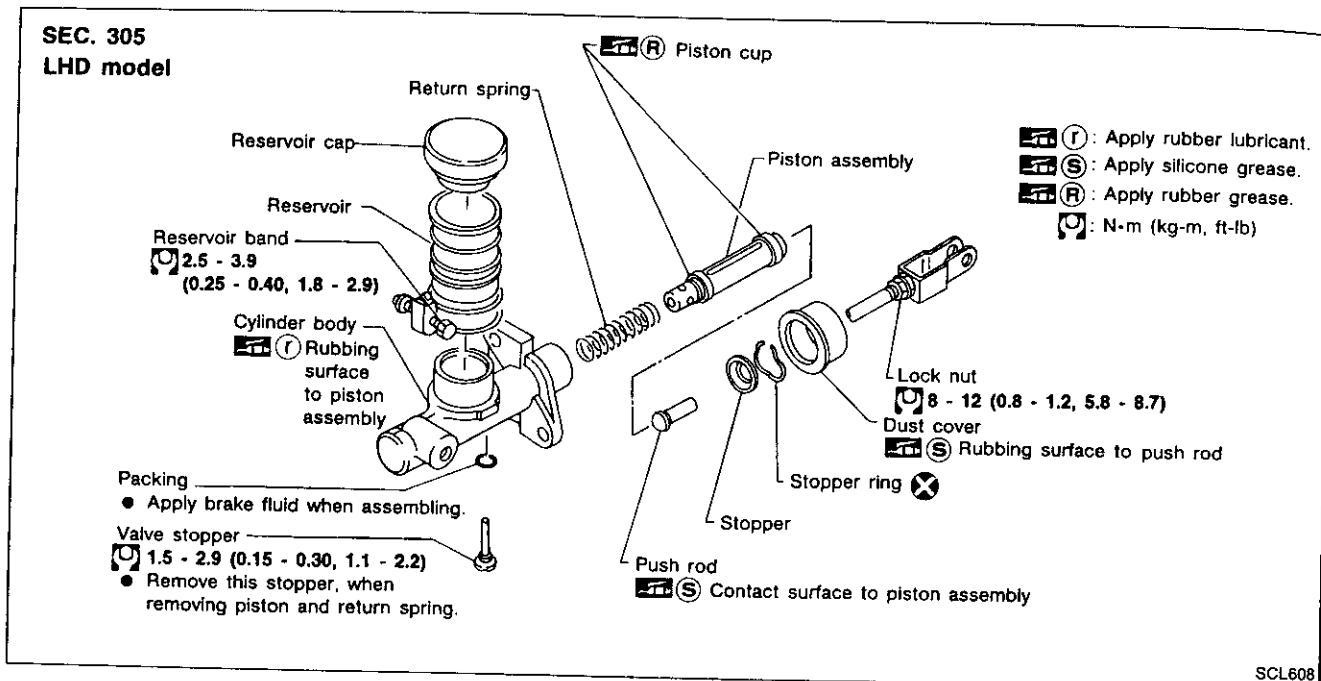

### DISASSEMBLY AND ASSEMBLY

- Push piston into cylinder body with screwdriver when removing and installing valve stopper.

## HYDRAULIC CLUTCH CONTROL

### Clutch Master Cylinder (Cont'd)

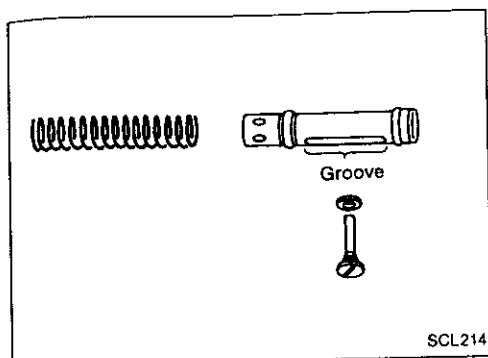

- Align groove of piston assembly and valve stopper when installing valve stopper.
- Check direction of piston cups.

GI

MA

EM

LC

### INSPECTION

- Check cylinder and piston rubbing surface for uneven wear, rust or damage. Replace if necessary.
- Check piston with piston cup for wear or damage. Replace if necessary.
- Check return spring for wear or damage. Replace if necessary.
- Check reservoir for deformation or damage. Replace if necessary.
- Check dust cover for cracks, deformation or damage. Replace if necessary.

EC

FE

CL

MT

### Operating Cylinder

SEC. 306

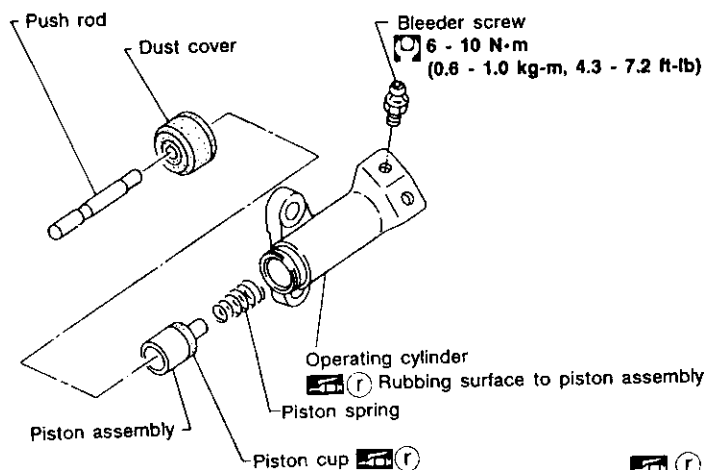

SCL590

AT

PD

FA

RA

BR

ST

RS

BT

HA

### INSPECTION

- Check rubbing surface of cylinder for wear, rust or damage. Replace if necessary.

EL

# CLUTCH RELEASE MECHANISM

SEC. 321

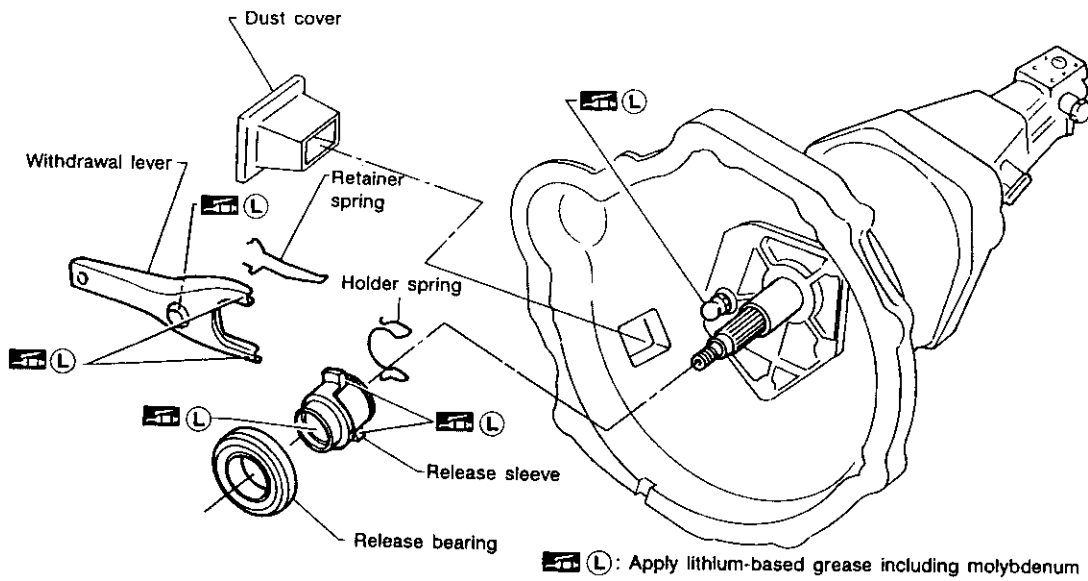

SCL617

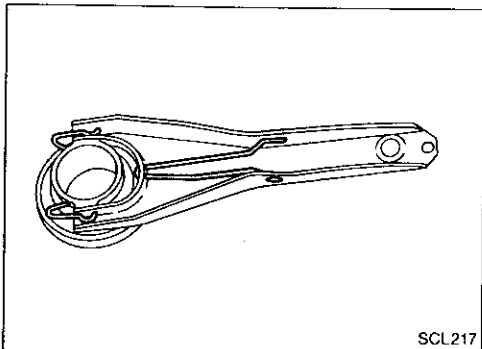

SCL217

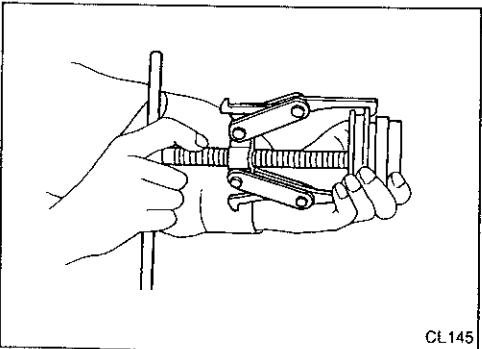

CL145

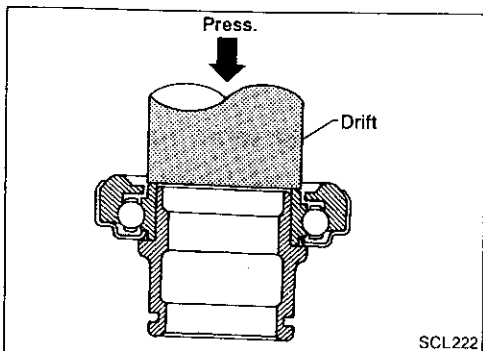

SCL222

## REMOVAL AND INSTALLATION

- Install retainer spring and holder spring.
  
- Remove release bearing.
  
- Install release bearing with suitable drift.

## CLUTCH RELEASE MECHANISM

### INSPECTION

- Check release bearing to see that it rolls freely and is free from noise, cracks, pitting or wear. Replace if necessary.
- Check release sleeve and withdrawal lever rubbing surface for wear, rust or damage. Replace if necessary.

GI

MA

EM

LC

EC

FE

CL

MT

AT

PD

FA

RA

RR

ST

RS

RT

HA

EL

IDX

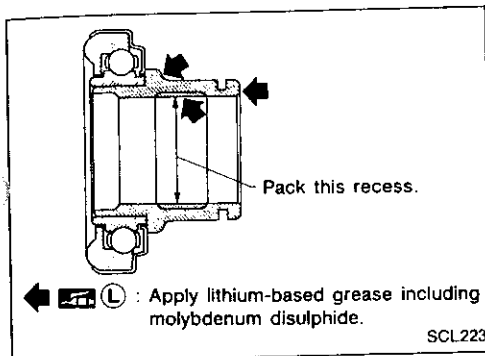

### LUBRICATION

- Apply recommended grease to contact surface and rubbing surface.

**Too much lubricant might damage clutch disc facing.**

## CLUTCH DISC AND CLUTCH COVER

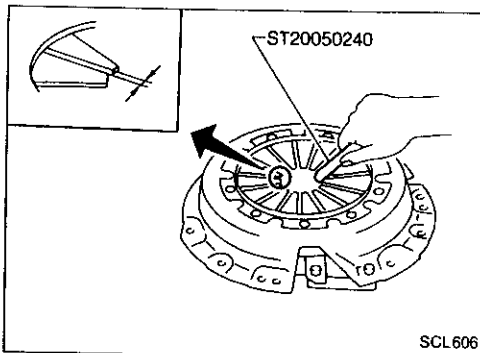
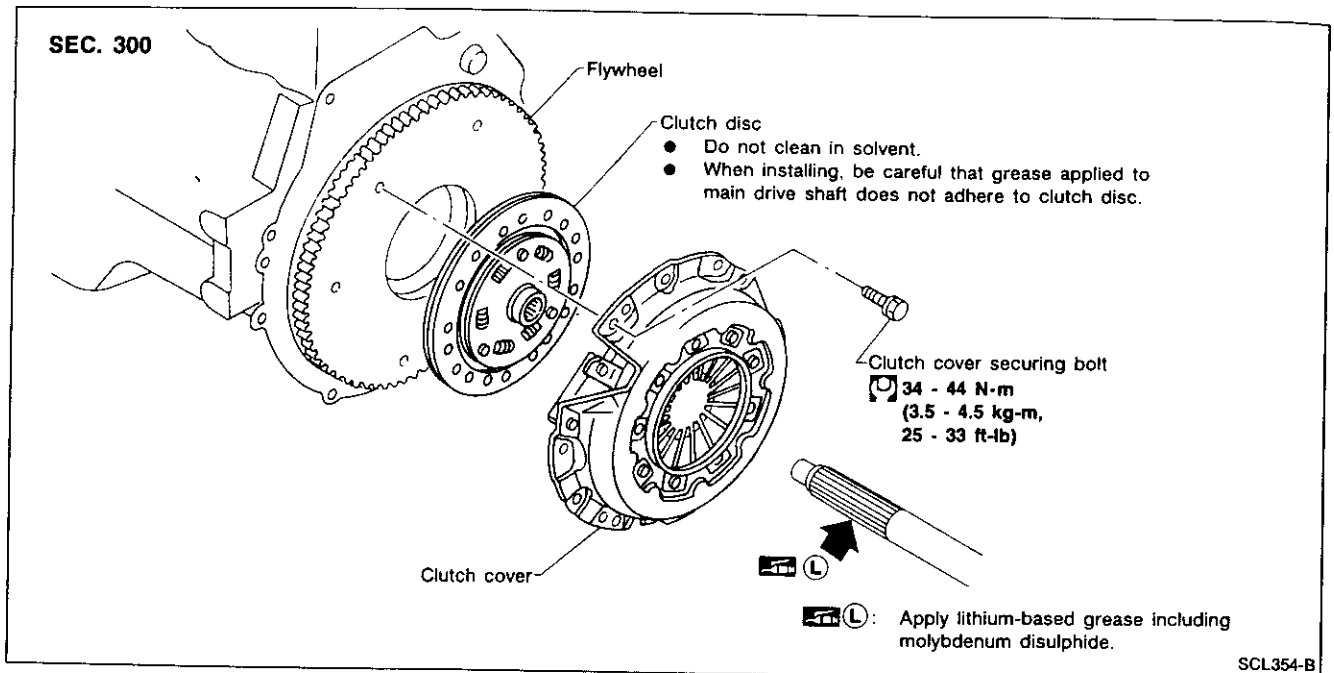

### Clutch Cover and Flywheel

#### INSPECTION AND ADJUSTMENT

- Check clutch cover installed on vehicle for unevenness of diaphragm spring toe height.

**Uneven limit:**

**0.5 mm (0.020 in)**

- If out of limit, adjust the height with Tool.

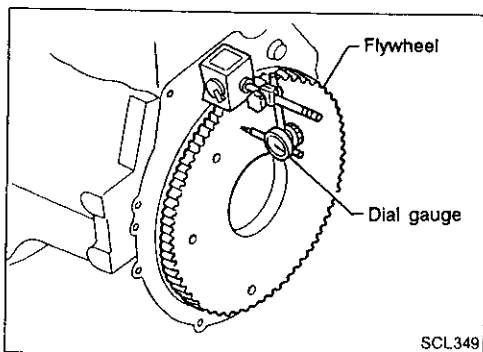

#### FLYWHEEL INSPECTION

- Check contact surface of flywheel for slight burns or discoloration. Repair flywheel with emery paper.
- Check flywheel runout.

**Maximum allowable runout:**

**Refer to EM section ("Inspection", "CYLINDER BLOCK").**

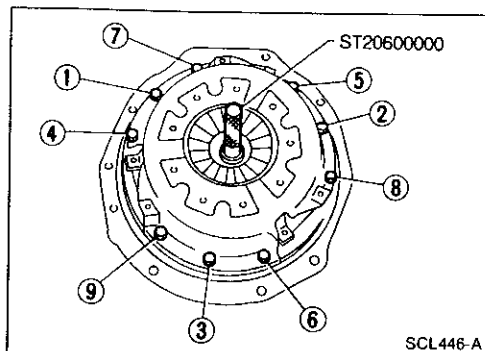

#### INSTALLATION

- Insert Tool into clutch disc hub when installing clutch cover and disc.
- Tighten bolts in numerical order.
- **Be careful not to allow grease to contaminate clutch facing.**

## CLUTCH DISC AND CLUTCH COVER

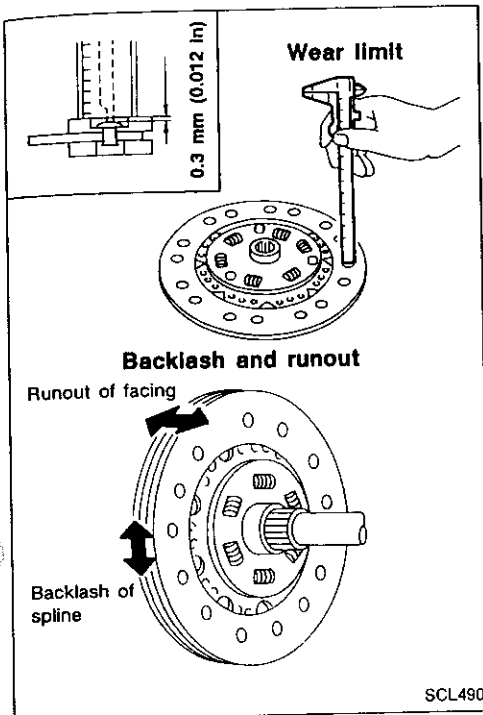

### Clutch Disc

#### INSPECTION

- Check clutch disc for wear of facing.  
**Wear limit of facing surface to rivet head:**  
0.3 mm (0.012 in)
- Check for backlash of spline and runout of facing.  
**Maximum backlash of spline (at outer edge of disc):**  
1.0 mm (0.039 in)  
**Runout limit:**  
1.0 mm (0.039 in)  
**Distance of runout check point (from hub center):**  
115 mm (4.53 in)
- Check clutch disc for burns, discoloration or oil or grease leakage. Replace if necessary.

#### INSTALLATION

- Apply recommended grease to contact surface of spring portion.  
**Too much lubricant might damage clutch disc facing.**

GI

MA

EM

LC

EC

EE

CL

MT

AT

PD

FA

BA

BR

ST

RS

BT

HA

EL

FDX



## SERVICE DATA AND SPECIFICATIONS (SDS)

### General Specifications

#### CLUTCH CONTROL SYSTEM

Type of clutch control	Hydraulic
------------------------	-----------

#### CLUTCH MASTER CYLINDER

Inner diameter	mm (in)	15.87 (5/8)
----------------	---------	-------------

#### CLUTCH OPERATING CYLINDER

Inner diameter	mm (in)	19.05 (3/4)
----------------	---------	-------------

#### CLUTCH DISC

		Unit: mm (in)
Model		240
Facing size (Outer dia. x inner dia. x thickness)		240 x 160 x 3.5 (9.45 x 6.30 x 0.138)
Thickness of disc assembly With load		7.9 - 8.3 (0.311 - 0.327) with 4,903 N (500 kg, 1,103 lb)

#### CLUTCH COVER

Model		240
Full load	N (kg, lb)	5,688 (580, 1,279)

### Inspection and Adjustment

#### CLUTCH PEDAL

			Unit: mm (in)
Model	LHD	RHD	
Pedal height "H"	192 - 202 (7.56 - 7.95)	188 - 198 (7.40 - 7.80)	
Pedal free play "A" (At pedal pad)	9 - 16 (0.35 - 0.63)		

\*: Measured from surface of melt sheet to pedal pad

#### CLUTCH COVER

		Unit: mm (in)
Model		240
Uneven limit of diaphragm spring toe height		0.5 (0.020)

#### CLUTCH DISC

		Unit: mm (in)
Model		240
Wear limit of facing surface to rivet head		0.3 (0.012)
Runout limit of facing		1.0 (0.039)
Distance of runout check point (from the hub center)		115 (4.53)
Maximum backlash of spline (at outer edge of disc)		1.0 (0.039)

# MANUAL TRANSMISSION

## SECTION **MT**

### CONTENTS

<b>PREPARATION</b> .....	2	Case Components.....	11
Special Service Tools.....	2	Shift Control Components.....	12
Commercial Service Tool.....	4	Gear Components.....	12
<b>ON-VEHICLE SERVICE</b> .....	5	<b>INSPECTION</b> .....	15
Replacing Rear Oil Seal.....	5	Shift Control Components.....	15
Check of Position Switches.....	5	Gear Components.....	15
<b>REMOVAL AND INSTALLATION</b> .....	6	<b>ASSEMBLY</b> .....	17
Removal.....	6	Gear Components.....	17
Installation.....	7	Shift Control Components.....	23
<b>MAJOR OVERHAUL</b> .....	8	Case Components.....	24
Case Components.....	8	<b>SERVICE DATA AND SPECIFICATIONS (SDS)</b> .....	27
Gear Components.....	9	General Specifications.....	27
Shift Control Components.....	10	Inspection and Adjustment.....	28
<b>DISASSEMBLY</b> .....	11		

GF

WA

EM

LC

EC

FE

CL

**MT**

AT

PD

FA

RA

BR

ST

RS

BT

HA

EL

IDX

# PREPARATION

## Special Service Tools

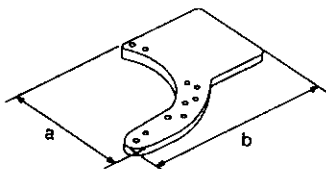
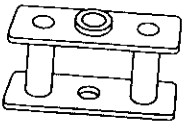
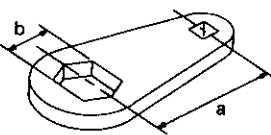
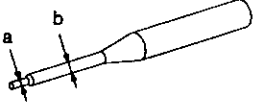
Tool number Tool name	Description
ST23810001 Adapter setting plate	<p data-bbox="1125 392 1556 436">Fixing adapter plate with gear assembly</p>  <p data-bbox="558 537 614 560">NT407</p> <p data-bbox="1117 526 1316 593">a: 166 mm (6.54 in) b: 270 mm (10.63 in)</p>
KV31100401 Transmission press stand	<p data-bbox="1117 604 1508 660">Pressing counter gear and mainshaft</p>  <p data-bbox="542 761 598 784">NT068</p>
ST22520000 Wrench	<p data-bbox="1101 828 1412 873">Tightening mainshaft lock nut</p>  <p data-bbox="534 985 590 1008">NT409</p> <p data-bbox="1093 974 1276 1041">a: 100 mm (3.94 in) b: 41 mm (1.61 in)</p>
ST23540000 Pin punch	<p data-bbox="1085 1052 1508 1108">Removing and installing fork rod retaining pin</p>  <p data-bbox="518 1209 574 1232">NT442</p> <p data-bbox="1077 1198 1316 1243">a: 2.3 mm (0.091 in) dia.</p>

## PREPARATION

### Special Service Tools (Cont'd)

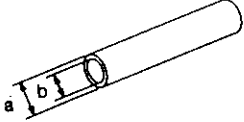
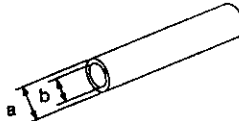
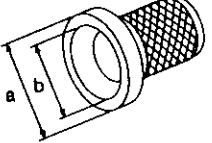
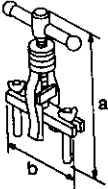
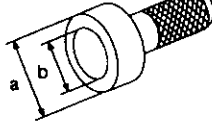
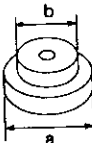
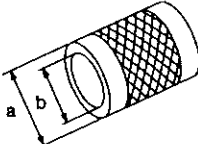
Tool number Tool name	Description	
ST22350000 Drift	Installing OD gear bushing  NT065 a: 34 mm (1.34 in) dia. b: 28 mm (1.10 in) dia.	GI VA EM
ST23800000 Drift	Installing front cover oil seal  NT065 a: 44 mm (1.73 in) dia. b: 31 mm (1.22 in) dia.	LC EC
ST33400001 Drift	Installing rear oil seal  NT086 a: 60 mm (2.36 in) dia. b: 47 mm (1.85 in) dia.	FE CL MT
ST33290001 Puller	Removing rear oil seal  NT414 a: 250 mm (9.84 in) b: 160 mm (6.30 in)	AT PD FA
ST30720000 Drift	Installing mainshaft ball bearing  NT115 a: 77 mm (3.03 in) dia. b: 55.5 mm (2.185 in) dia.	RA BR
ST30613000 Drift	Installing main drive gear bearing  NT073 a: 71.5 mm (2.815 in) dia. b: 47.5 mm (1.870 in) dia.	ST RS BT
ST33200000 Drift	Installing counter rear bearing Installing 3rd & 4th synchronizer assembly  NT091 a: 60 mm (2.36 in) dia. b: 44.5 mm (1.752 in) dia.	HA EL

## PREPARATION

### Special Service Tools (Cont'd)

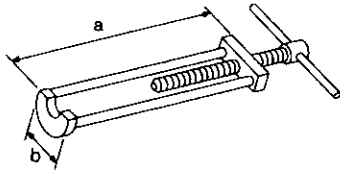
Tool number Tool name	Description
KV32101330 Puller	 <p>Removing overdrive mainshaft bearing</p> <p>a: 447 mm (17.60 in) b: 100 mm (3.94 in)</p> <p>NT408</p>

### Commercial Service Tool

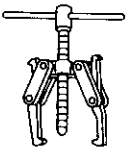
Tool name	Description
Puller	 <p>Removing counter bearings, counter drive and OD gears</p> <p>NT077</p>

## ON-VEHICLE SERVICE

### Replacing Rear Oil Seal

#### REMOVAL

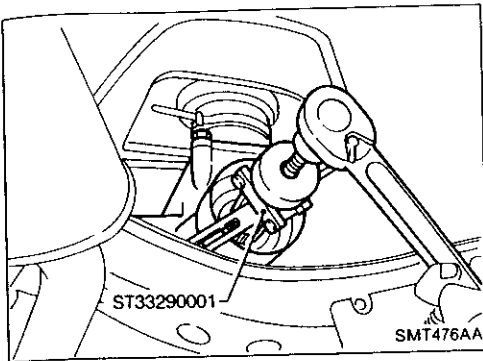

#### INSTALLATION

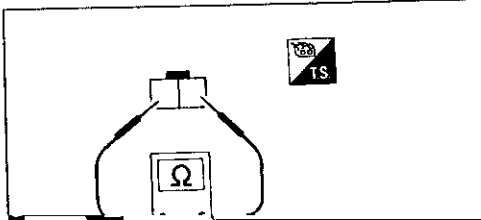
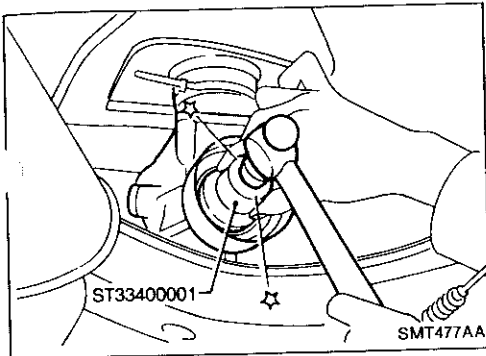

#### Check of Position Switches

Switch	Gear position	Continuity
Reverse lamp switch	Reverse	Yes
	Other than reverse	No
Neutral position switch	Neutral	Yes
		No

GI

MA

EM

LC

EC

FE

CL

MT

AT

PD

# REMOVAL AND INSTALLATION

## Removal

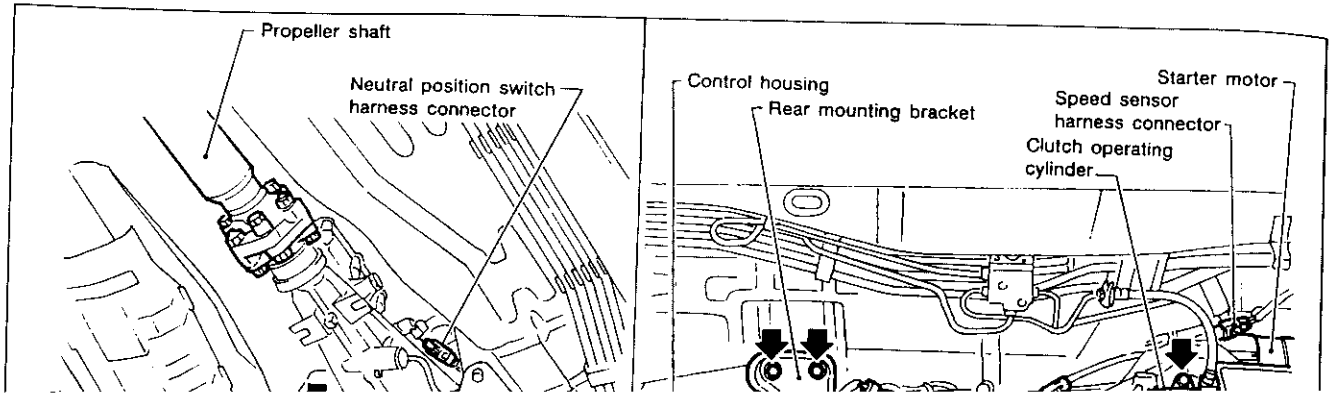

## REMOVAL AND INSTALLATION

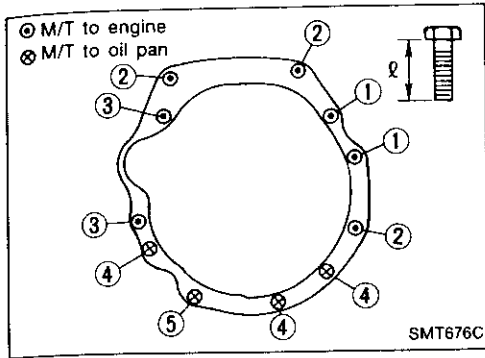

### Installation

- Tighten transmission fixing bolts.

Bolt No.	Tightening torque N·m (kg-m, ft-lb)	"L" mm (in)
①	70 - 79 (7.1 - 8.1, 51 - 59)	68 (2.68)
②	70 - 79 (7.1 - 8.1, 51 - 59)	63 (2.48)
③	70 - 79 (7.1 - 8.1, 51 - 59)	78 (3.07)
④	29 - 39 (3.0 - 4.0, 22 - 29)	60 (2.36)
⑤	29 - 39 (3.0 - 4.0, 22 - 29)	30 (1.18)

- Install any part removed.

GE

MA

EM

LC

EC

FE

CL

**MT**

AT

PD

FA

RA

BR

ST

RS

BT

HA

EL

IDX



# MAJOR OVERHAUL

## Case Components

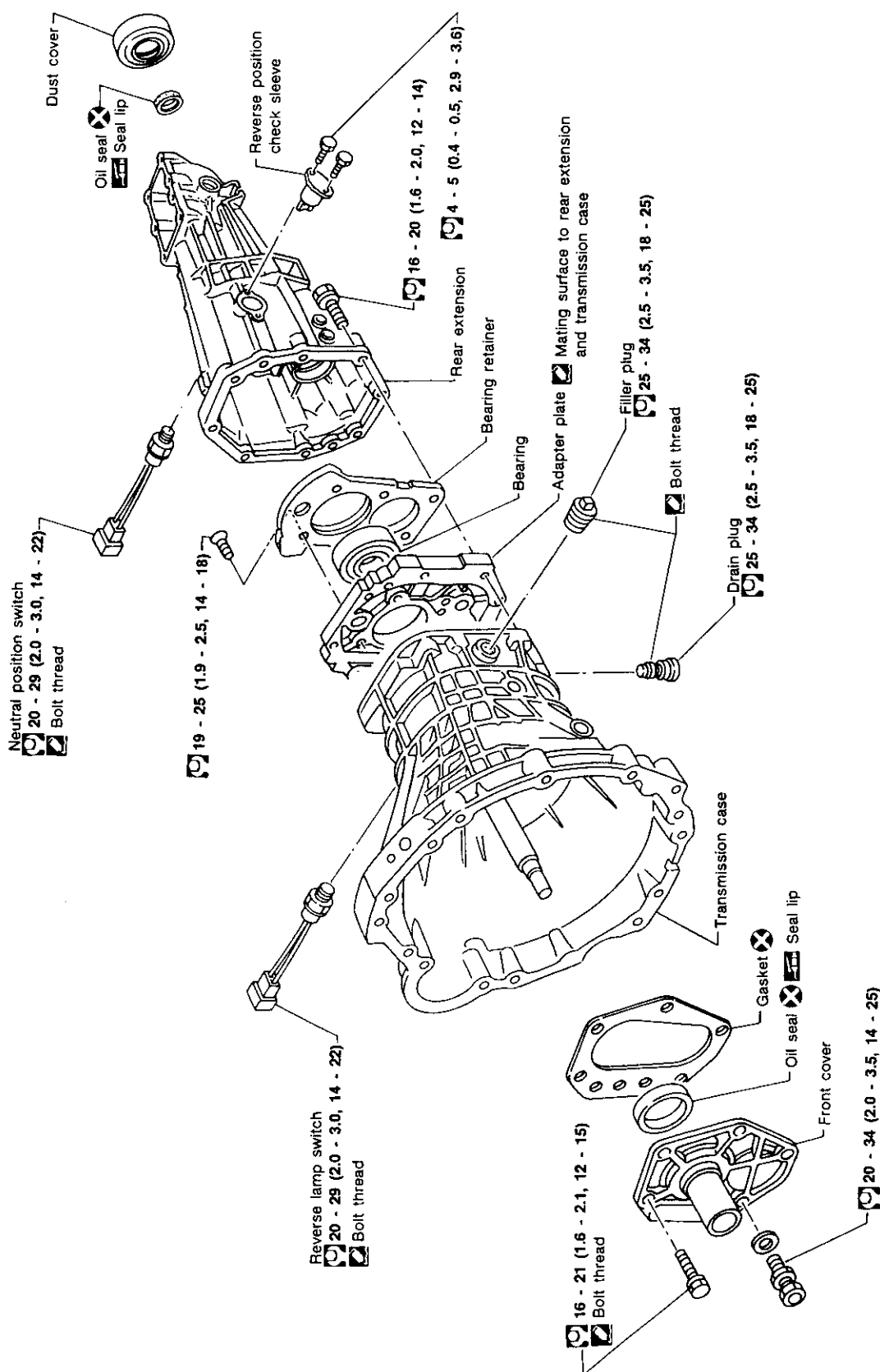

: N·m (kg·m, ft·lb)  
 : Apply recommended sealant  
 (Nissan genuine part: KP610-00250) or equivalent.

SEC. 320-321

MT-8

SMT677C

# MAJOR OVERHAUL

## Gear Components

SEC. 322

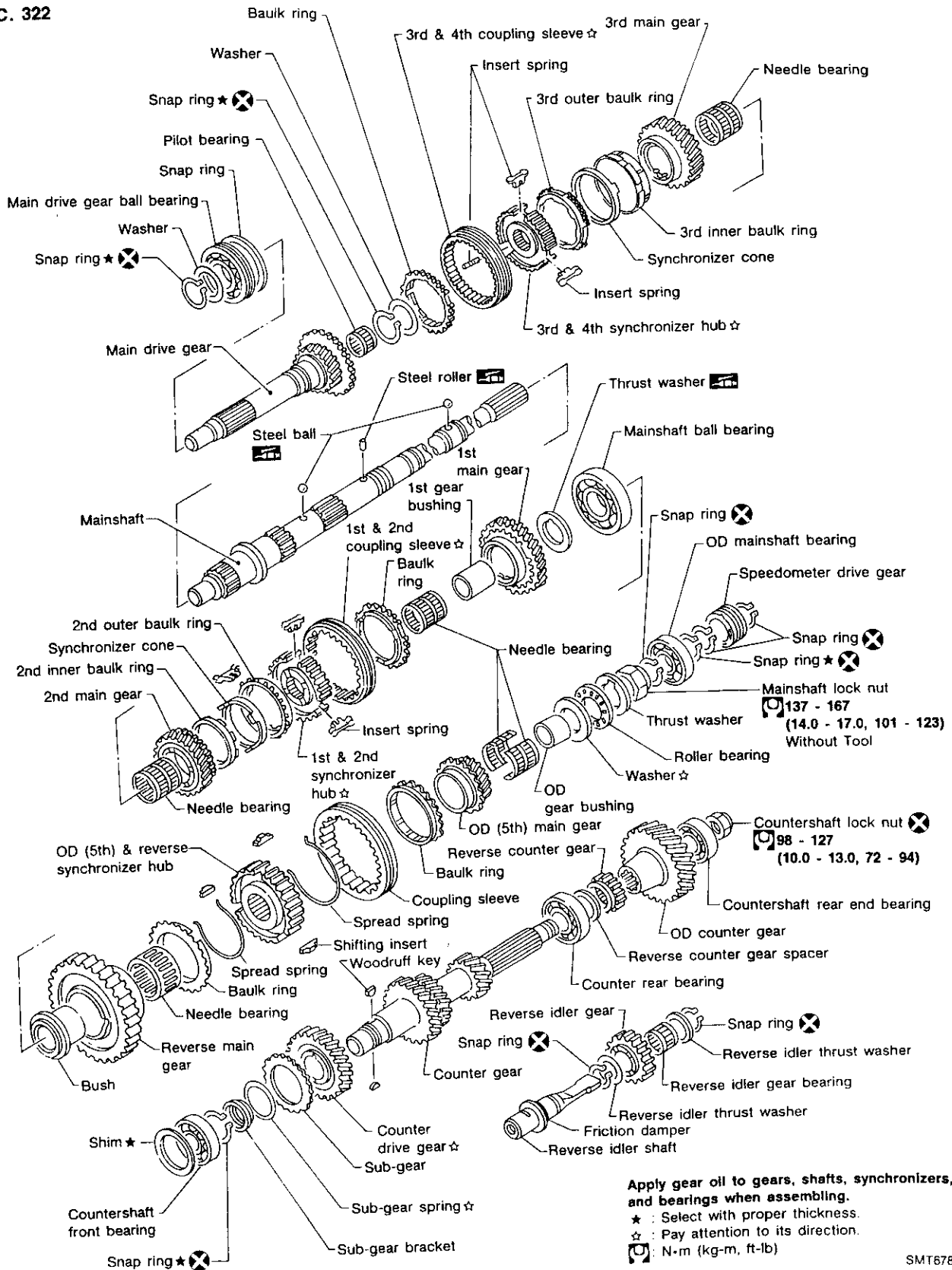

Apply gear oil to gears, shafts, synchronizers, and bearings when assembling.  
 \* : Select with proper thickness.  
 ☆ : Pay attention to its direction.  
 □ : N-m (kg-m, ft-lb)

SMT678C

GI  
 VA  
 EM  
 LC  
 EC  
 FE  
 CL  
**MT**  
 AT  
 PD  
 FA  
 RA  
 BR  
 ST  
 RS  
 BT  
 HA  
 EL  
 IDX

# MAJOR OVERHAUL

## Shift Control Components

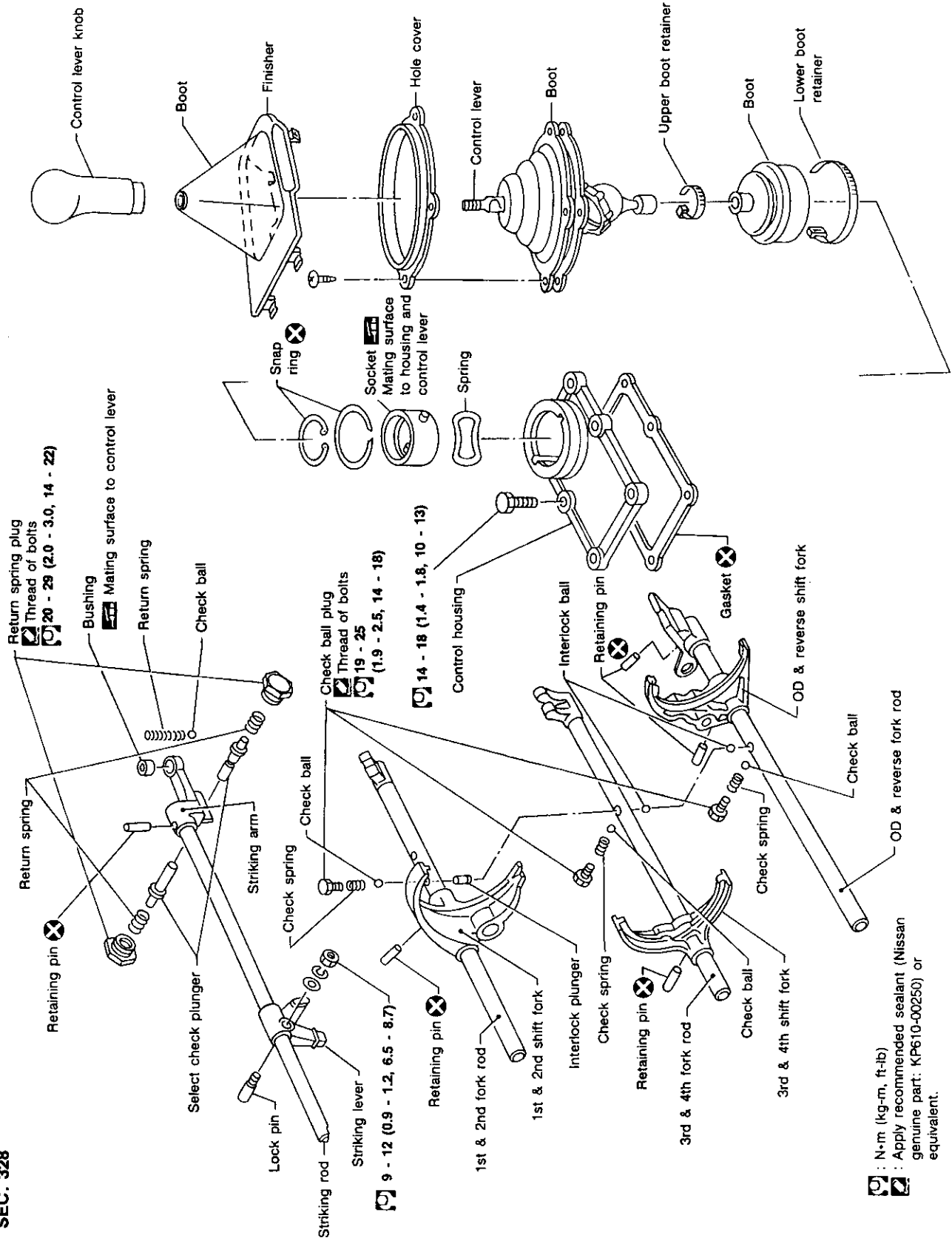

SEC. 328

: N·m (kg-m, ft·lb)  
 : Apply recommended sealant (Nissan genuine part: KP610-00250) or equivalent.

## DISASSEMBLY

### Case Components

1. Remove rear extension.
  - a. Remove control housing, check ball, return spring plug, select check plunger and return springs.

GI

MA

EM

LC

EC

FE

CL

**MT**

AT

PD

FA

RA

BR

ST

RS

BT

HA

EL

IDX

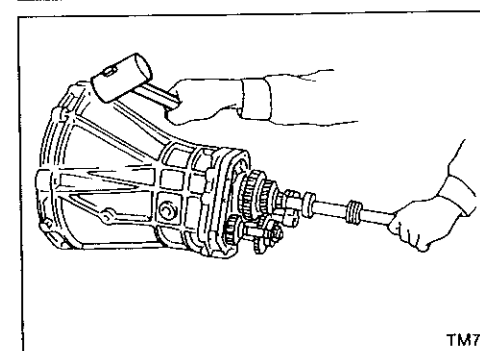
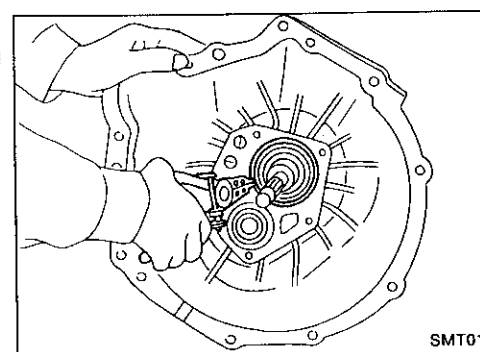
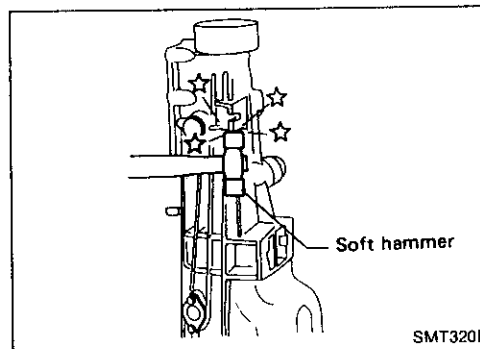
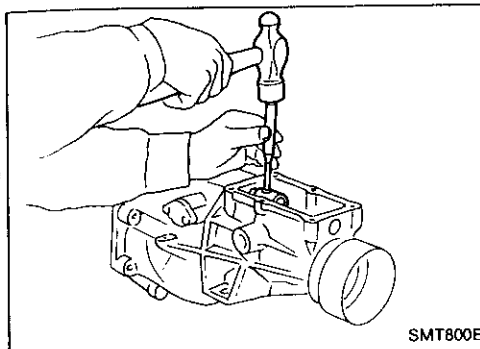
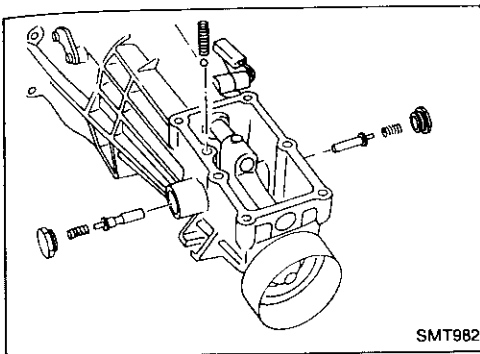

- b. Drive out striking arm retaining pin.
- c. Remove striking arm from striking rod.

- d. Remove rear extension by lightly tapping it.

2. Remove front cover, gasket, shim of countershaft front bearing, and snap ring of main drive gear ball bearing.

3. Remove transmission case by tapping lightly.

## DISASSEMBLY

### Case Components (Cont'd)

4. Remove front cover oil seal.

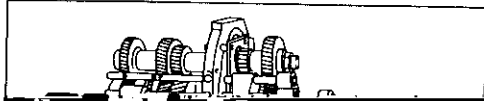
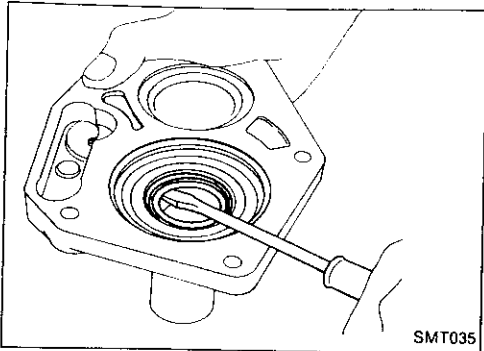

### Shift Control Components

1. Set up Tool on adapter plate.

2. Remove shift...

## DISASSEMBLY

### Gear Components (Cont'd)

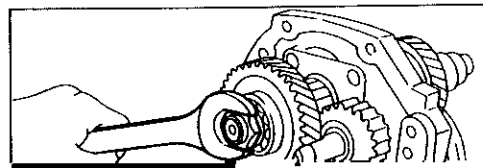
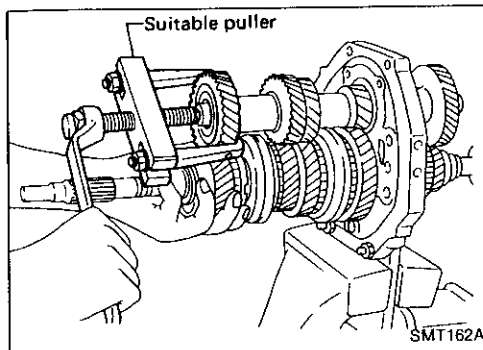
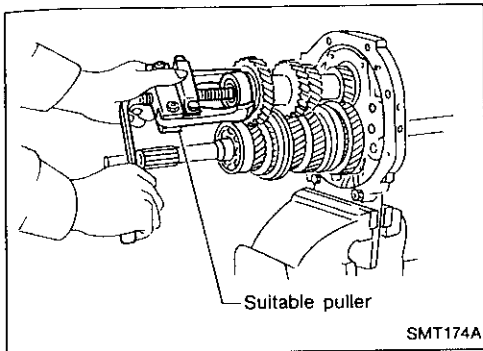

2. Mesh 2nd and reverse gear, then draw out counter front bearing with suitable puller.
3. Remove snap ring and then remove sub-gear bracket, sub-gear spring and sub-gear.

GI

MA

EM

4. Draw out counter drive gear with main drive gear assembly with suitable puller.

LC

- When drawing out main drive gear assembly, be careful not to drop pilot bearing and baulk ring.

EC

FE

CL

5. Remove rear side components on mainshaft and counter gear.

MT

- a. Release staking on countershaft nut and mainshaft nut and loosen these nuts.

AT

**Mainshaft nut: Left-hand thread**

DN

## DISASSEMBLY

### Gear Components (Cont'd)

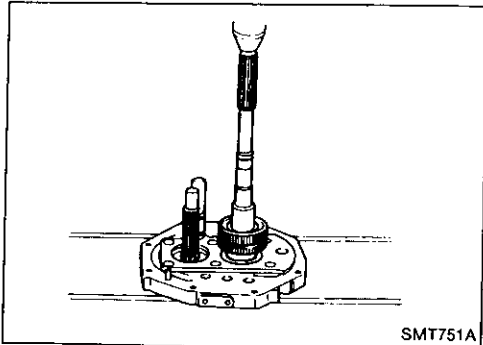

- I. Press out mainshaft and counter gear alternately.
- Press down mainshaft and counter gear alternately and carefully. Do not allow gears attached to mainshaft and counter gear underneath adapter plate to hit each other.

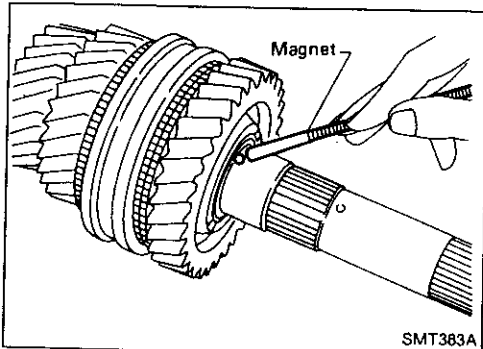

6. Remove front side components on mainshaft.
  - a. Remove 1st gear washer and steel ball.
  - b. Remove 1st main gear and 1st gear needle bearing.

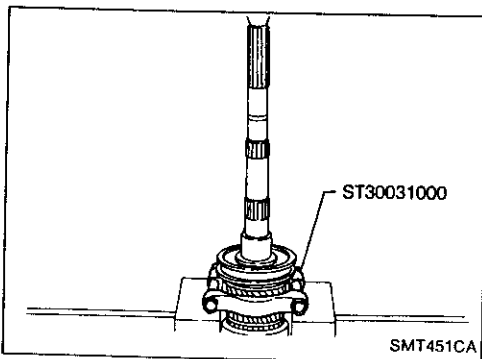

- c. Press out 2nd main gear together with 1st gear bushing and 1st & 2nd synchronizer assembly.
  - d. Remove mainshaft front snap ring.

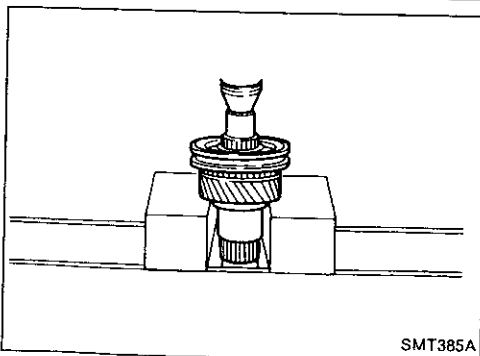

- e. Press out 3rd main gear together with 3rd & 4th synchronizer assembly and 3rd gear needle bearing.

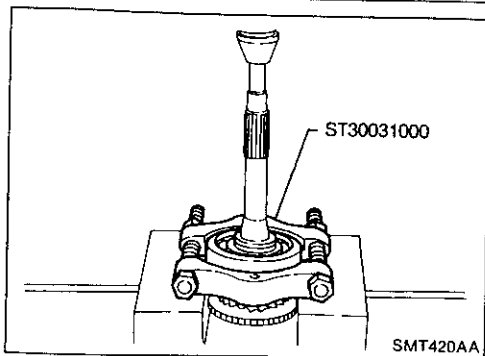

7. Remove main drive gear bearing.
  - a. Remove main drive gear snap ring and spacer.
  - b. Press out main drive gear bearing.

## INSPECTION

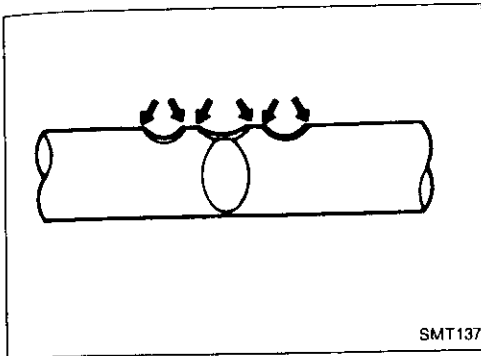

### Shift Control Components

- Check contact surface and sliding surface for wear, scratches, projections or other damage.

GI

VA

EM

LC

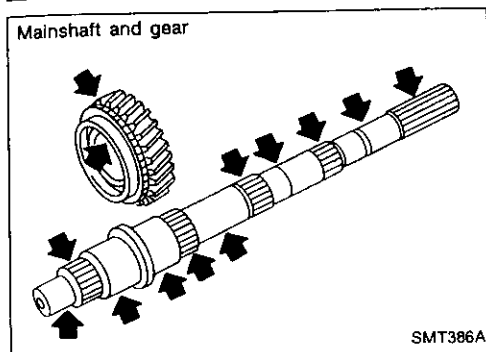

### Gear Components

#### GEAR AND SHAFT

- Check shafts for cracks, wear or bending.
- Check gears for excessive wear, chips or cracks.

EC

FE

CL

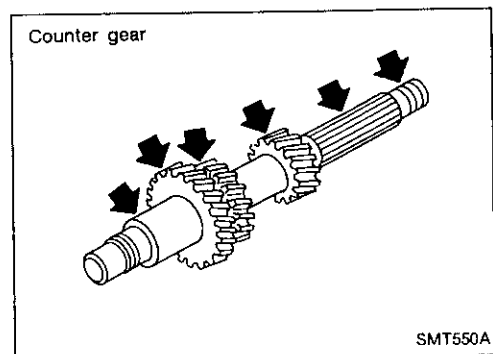

MT

AT

PD

FA

RA

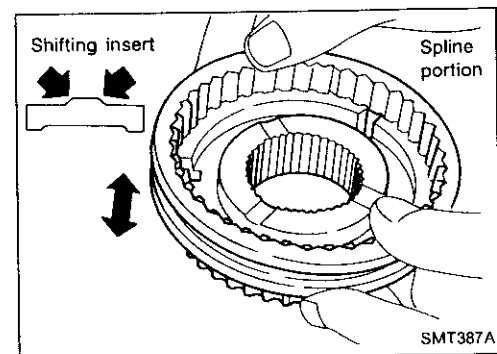

#### SYNCHRONIZERS

- Check spline portion of coupling sleeves, hubs and gears for wear or cracks.
- Check baulk rings for cracks or deformation.
- Check shifting inserts for wear or deformation.
- Check spread spring for deformation.

BR

ST

RS

BT

HA

EL

DX



## INSPECTION

### Gear Components (Cont'd)

- Measure clearance between baulk ring and gear.  
**Clearance between baulk ring and gear (1st, main drive, OD and reverse baulk ring):**

Unit: mm (in)

Dimension	Standard	Wear limit
1st	1.2 - 1.6 (0.047 - 0.063)	0.8 (0.031)
Main drive	1.2 - 1.6 (0.047 - 0.063)	
OD	1.2 - 1.6 (0.047 - 0.063)	
Reverse	1.10 - 1.55 (0.0433 - 0.0610)	0.7 (0.028)

If the clearance is smaller than the wear limit, replace baulk ring.

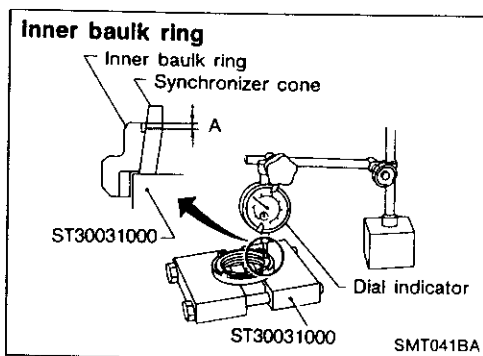
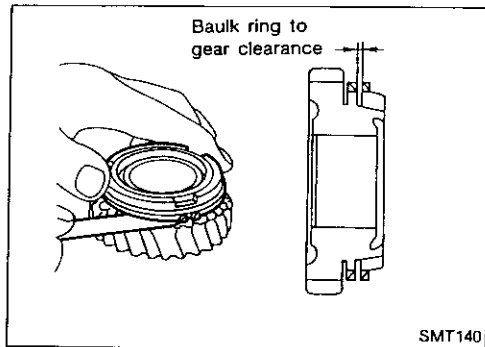

- Measure wear of 2nd and 3rd baulk rings.
  - Place inner baulk ring in position on synchronizer cone.
  - Hold baulk ring evenly against synchronizer cone and measure distance "A".
  - Place outer baulk ring in position on synchronizer cone.
  - Hold baulk ring evenly against synchronizer cone and measure distance "B".

**Standard:**

**Inner-A 0.6 - 1.1 mm (0.024 - 0.043 in)**

**Outer-B 0.7 - 0.9 mm (0.028 - 0.035 in)**

**Wear Limit:**

**0.2 mm (0.008 in)**

- If distance "A" or "B" is smaller than the wear limit, replace baulk ring.

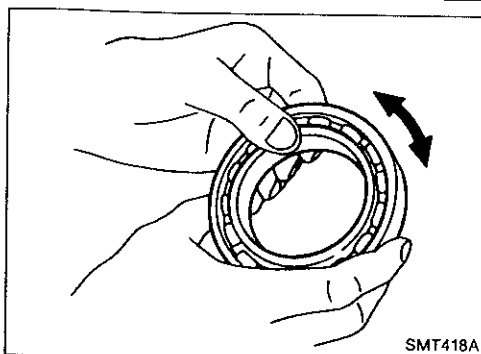
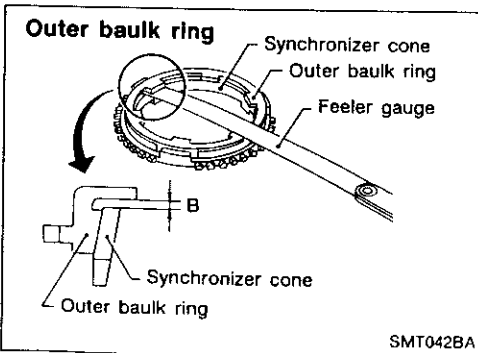

### BEARINGS

- Make sure bearings roll freely and are free from noise, crack, pitting or wear.

# ASSEMBLY

## Gear Components

1. Install bearings into case components.

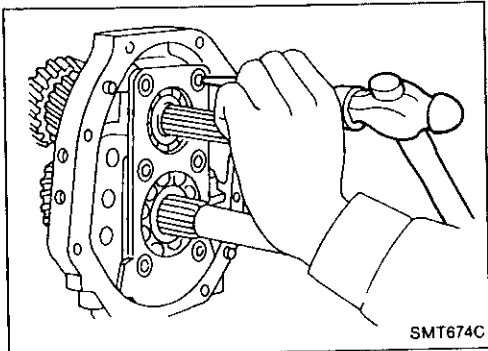
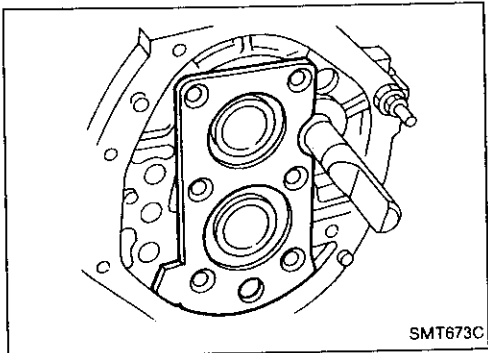
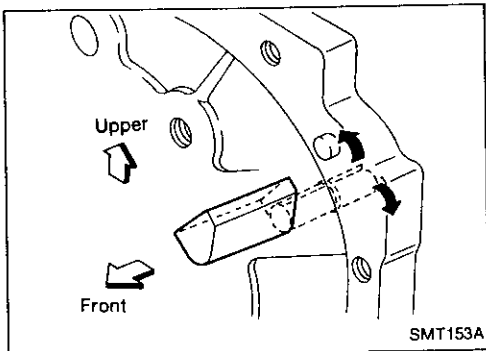
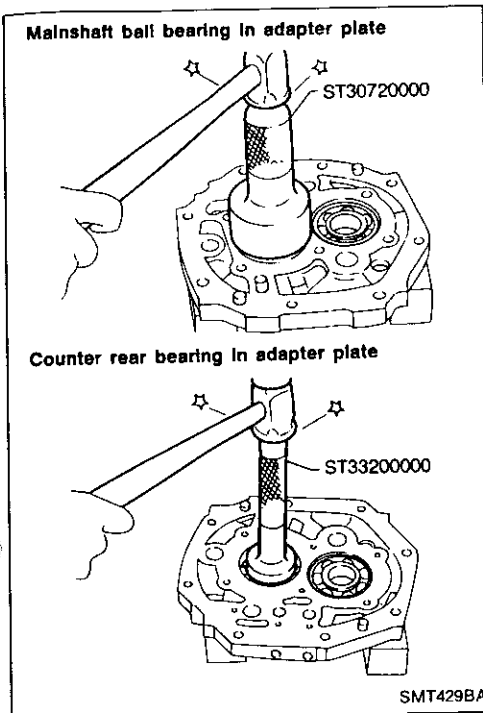

2. Assemble adapter plate parts.

- Install oil gutter on adapter plate and expand on rear side.

- Install bearing retainer.

- a. Insert reverse shaft, then install bearing retainer.

- b. Tighten each screw, then stake each at two points.

GI

MA

EM

LC

EC

FE

CL

**MT**

AT

PD

FA

RA

BR

ST

RS

BT

HA

EL

IDX

## ASSEMBLY

### Gear Components (Cont'd)

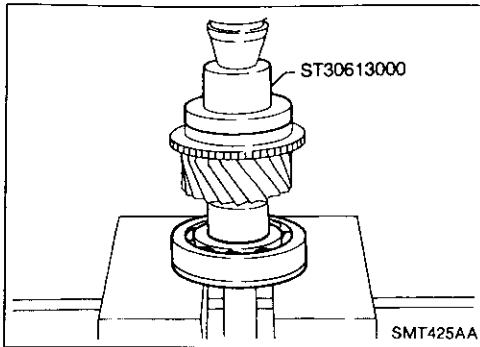

3. Install main drive gear bearing.
  - a. Press main drive gear bearing.
  - b. Install main drive gear spacer.

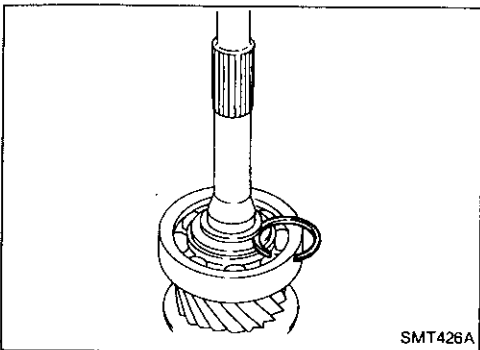

- c. Select proper main drive gear snap ring to minimize clearance of groove and install it.

**Allowable clearance of groove:**

**0 - 0.13 mm (0 - 0.0051 in)**

**Main drive gear snap ring:**

**Refer to SDS, MT-28.**

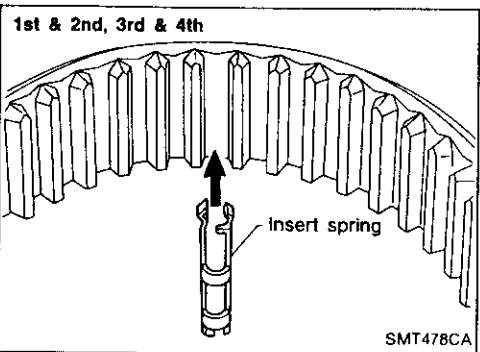

4. Assemble synchronizers.
  - 1st & 2nd, 3rd & 4th synchronizers

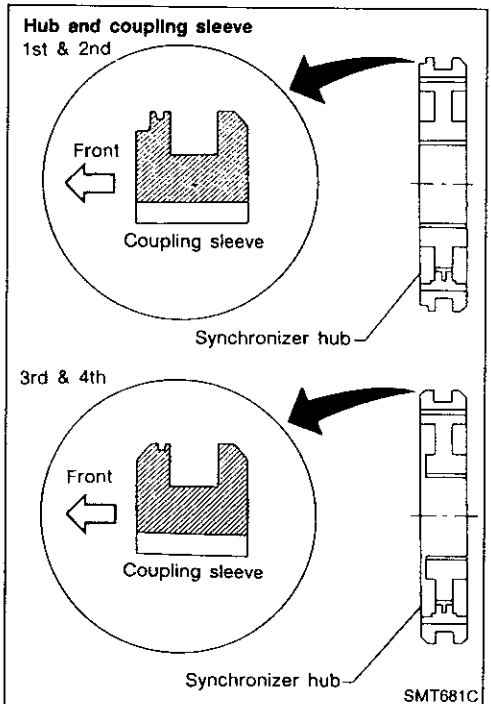

- Check coupling sleeve and synchronizer hub orientation.

# ASSEMBLY

## Gear Components (Cont'd)

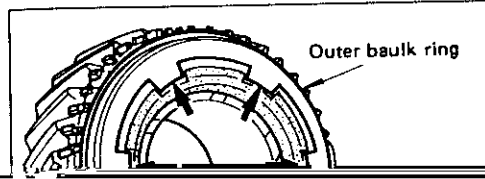
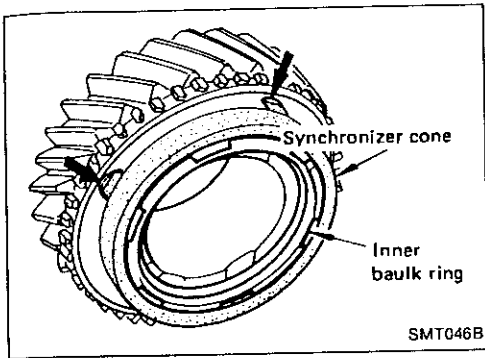

GI

MA

EM

LC

EC

BE

## ASSEMBLY

### Gear Components (Cont'd)

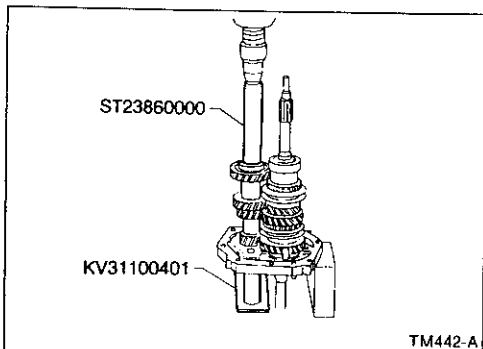
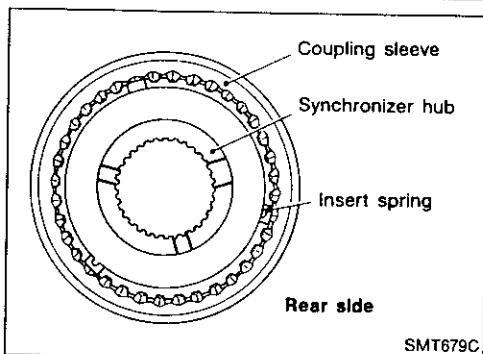
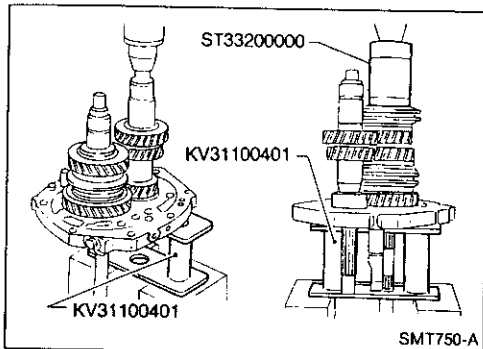
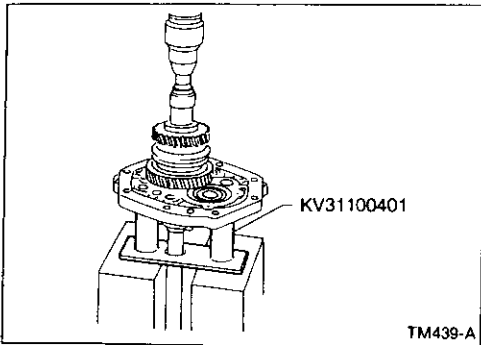

6. Install mainshaft and counter gear on adapter plate and main drive gear on mainshaft.
  - a. Press mainshaft assembly to adapter plate with Tool.

- b. Press counter gear into adapter plate with Tool.
  - c. Install 3rd main gear and then press 3rd & 4th synchronizer assembly.

- Pay attention to direction of 3rd & 4th synchronizer.

- d. Install thrust washer on mainshaft and secure it with mainshaft front snap ring. Select proper snap ring to minimize clearance of groove in mainshaft.

**Allowable clearance of groove:**

0 - 0.18 mm (0 - 0.0071 in)

**Mainshaft front snap ring:**

Refer to SDS, MT-28.

- e. Apply gear oil to mainshaft pilot bearing and install it on mainshaft.
  - f. Press counter drive gear with main drive gear with Tool.

## ASSEMBLY

### Gear Components (Cont'd)

- Pay attention to direction of counter drive gear.

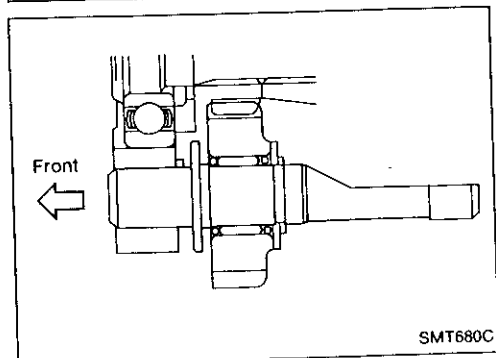
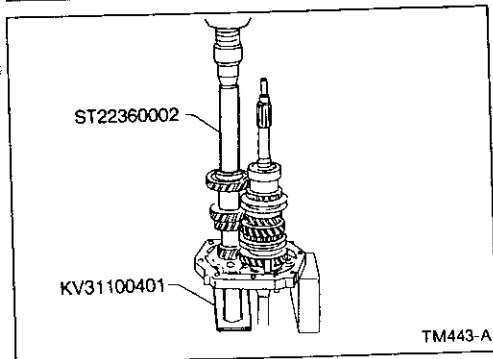
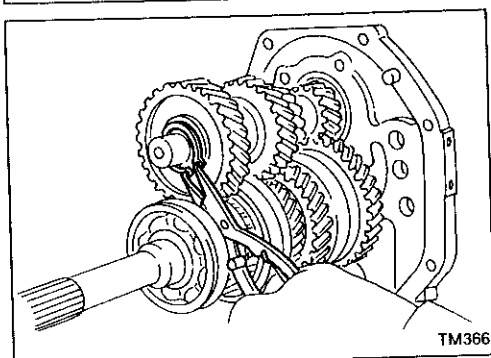
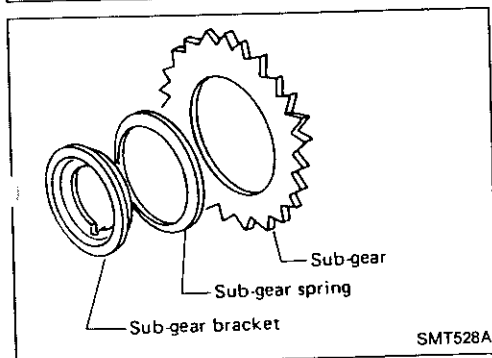
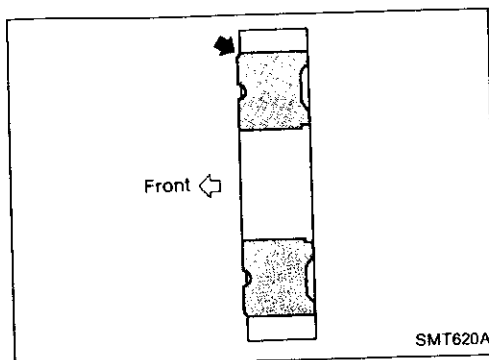

g. Install sub-gear components.

- (1) Install sub-gear and sub-gear bracket on counter drive gear. Then select proper snap ring to minimize clearance of groove in counter gear.

**Allowable clearance of groove:**  
0 - 0.13 mm (0 - 0.0051 in)

**Counter drive gear snap ring: Refer to SDS, MT-28.**

- (2) Remove snap ring, sub-gear bracket and sub-gear from counter gear.
- (3) Reinstall sub-gear, sub-gear spring and sub-gear bracket.

h. Install selected counter drive gear snap ring.

i. Press counter gear front bearing onto counter gear.

7. Install rear side components on mainshaft and counter gear.

- a. Install reverse idler gear to reverse idler shaft with spacers, snap rings and needle bearing.

GI

MA

EM

LC

EC

FE

CL

MT

AT

PD

FA

RA

BR

ST

RS

BT

HA

EL

IDX

## ASSEMBLY

### Gear Components (Cont'd)

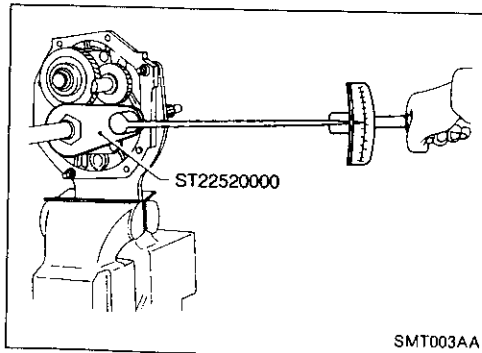
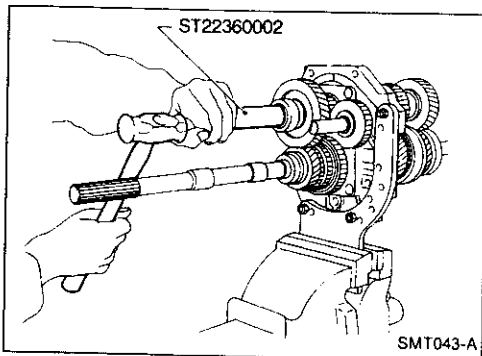
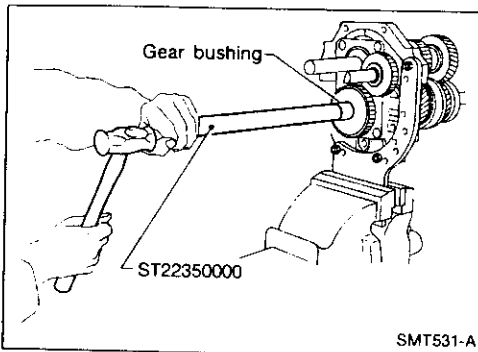
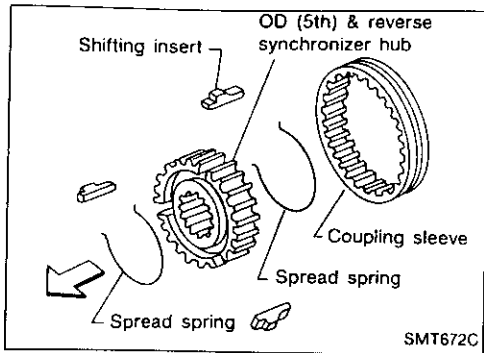

- b. Install insert retainer and OD & reverse synchronizer to mainshaft.
  - Pay attention to direction of hub.

- c. Install OD gear bushing with Tool.
- d. Install OD main gear and needle bearing.
- e. Install spacer, reverse counter gear and OD counter gear.
  - OD main gear and OD counter gear should be handled as a matched set.
- f. Install washer, roller bearing, steel roller and thrust washer.
- g. Tighten mainshaft lock nut temporarily.
  - Always use new lock nut.

- h. Install countershaft rear end bearing with Tool.

8. Mesh 2nd and reverse gears, then tighten mainshaft lock nut with Tool.

## ASSEMBLY

### Gear Components (Cont'd)

- Use the left chart when deciding the reading torque. (Length of torque wrench vs. setting or reading torque)
- 9. Tighten countershaft lock nut.
- **Always use new lock nut.**

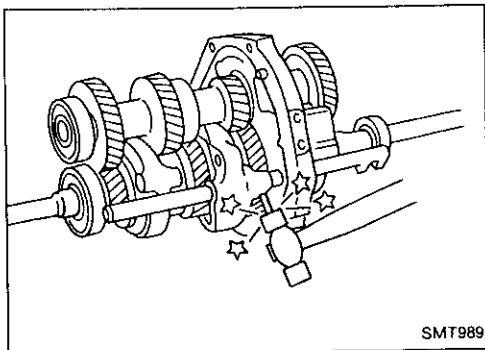
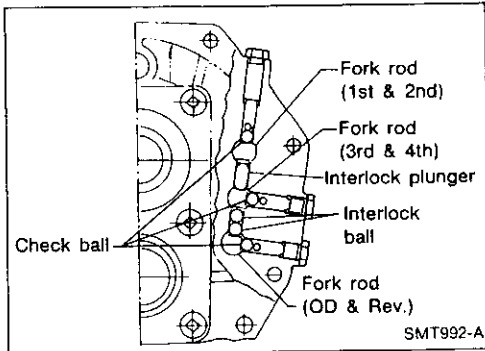
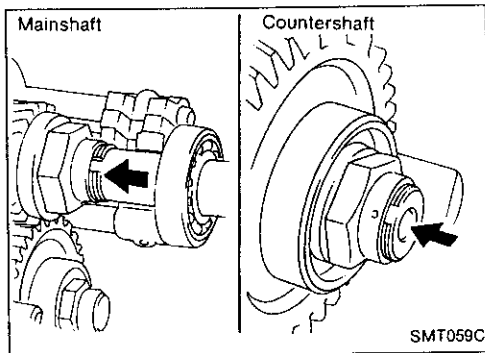
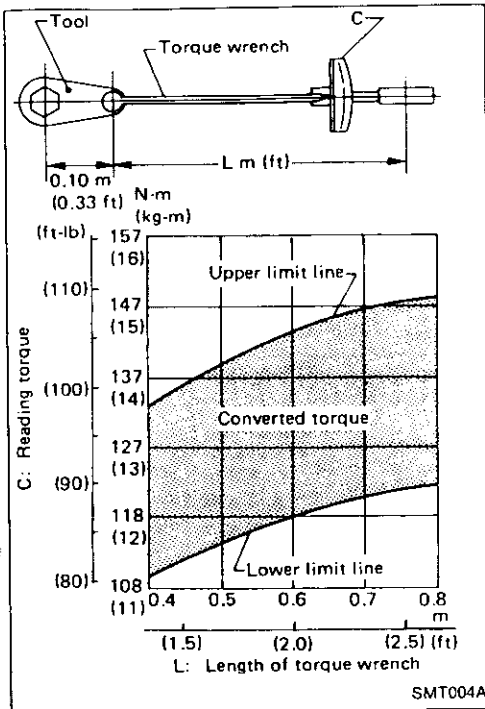

10. Stake mainshaft lock nut and countershaft lock nut with a punch.
11. Measure gear end play. For the description, refer to DIS-ASSEMBLY for Gear Components, MT-12.

### Shift Control Components

1. Install shift rods, interlock plunger, interlock balls and check balls.

- a. 1st-2nd shift fork

GI

MA

EM

LC

EC

FE

CL

MT

AT

PD

FA

RA

BR

ST

RS

BT

HA

EL

IDX



## ASSEMBLY

### Shift Control Components (Cont'd)

b. 3rd-4th shift fork

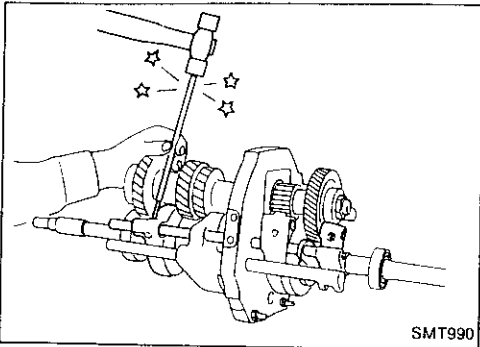

c. OD-reverse shift fork or reverse shift fork

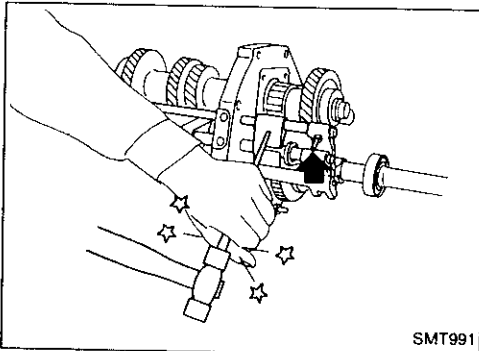

### Case Components

1. Install front cover oil seal.
  - Apply multi-purpose grease to seal lip of oil seal before installing.

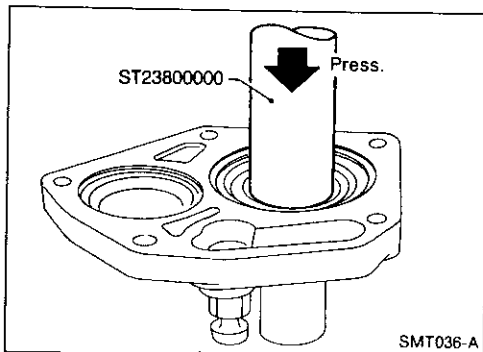

2. Apply sealant to mating surface of transmission case.

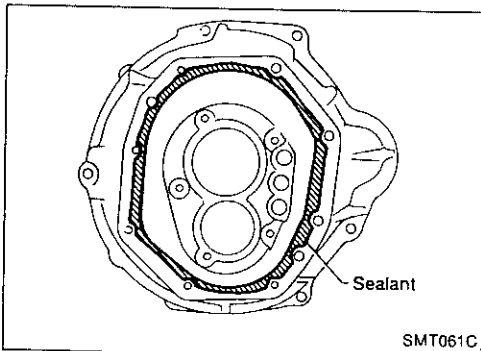

3. Install gear assembly onto transmission case.

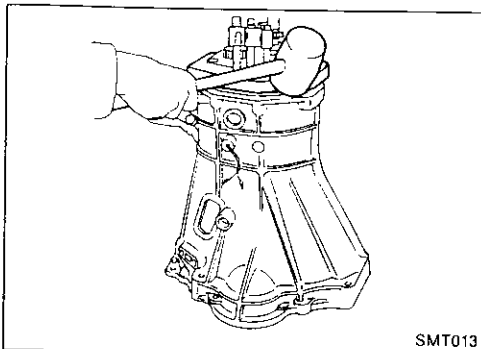

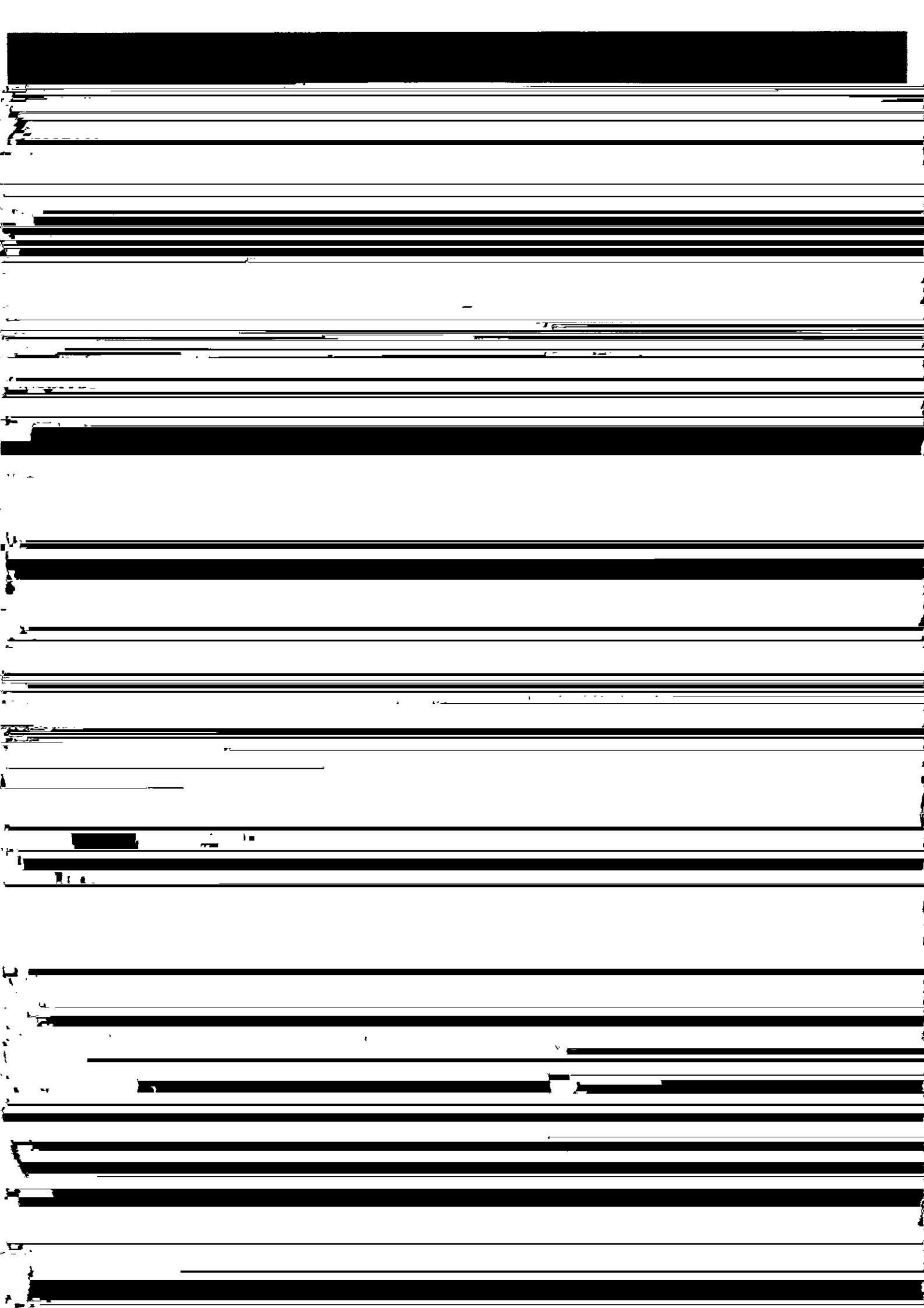

## ASSEMBLY

### Case Components (Cont'd)

12. Install return spring plugs, check ball, return springs and select check plunger.
13. Install control housing and gasket.

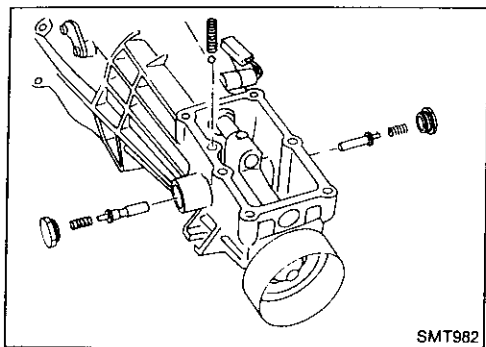

## SERVICE DATA AND SPECIFICATIONS (SDS)

### General Specifications

Transmission model		FS5W71C	GI
Number of speeds		5	MA
Shift pattern			EM
Synchronesh type		Warner	LC
Gear ratio	1st	3.321	EC
	2nd	1.902	FE
	3rd	1.308	CL
	4th	1.000	MT
	OD	0.838	AT
	Reverse	3.382	PD
Number of teeth			FA
Mainshaft	Drive	22	RA
	1st	33	BR
	2nd	27	ST
	3rd	26	RS
	OD	22	BT
	Reverse	36	HA
Countershaft	Drive	31	EL
	1st	14	IX
	2nd	20	
	3rd	28	
	OD	37	
	Reverse	15	
Reverse idler gear		21	
Oil capacity                      ℓ (Imp pt)		2.5 (4-3/8)	
Remarks	Sub-gear	○	
	Reverse synchronizer	○	
	Double baulk ring type synchronizer	2nd and 3rd synchronizer	

## SERVICE DATA AND SPECIFICATIONS (SDS)

### Inspection and Adjustment

#### GEAR END PLAY

Gear	End play mm (in)
1st gear	0.31 - 0.41 (0.0122 - 0.0161)
2nd gear	0.11 - 0.21 (0.0043 - 0.0083)
3rd gear	0.11 - 0.21 (0.0043 - 0.0083)
OD gear	0.24 - 0.41 (0.0094 - 0.0161)

#### CLEARANCE BETWEEN BAULK RING AND GEAR

##### 1st, main drive, OD and reverse baulk ring

Unit: mm (in)

	Standard	Wear limit
1st	1.2 - 1.6 (0.047 - 0.063)	0.8 (0.031)
Main drive	1.2 - 1.6 (0.047 - 0.063)	
OD	1.2 - 1.6 (0.047 - 0.063)	
Reverse	1.10 - 1.55 (0.0433 - 0.0610)	0.7 (0.028)

##### 2nd and 3rd baulk ring

Unit: mm (in)

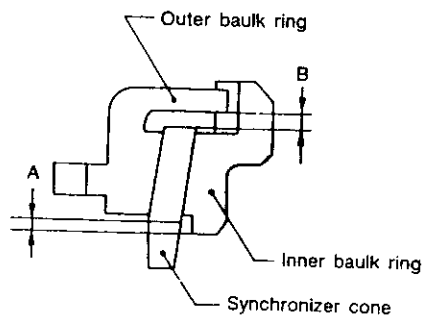

Dimension	Standard	Wear limit
A	0.6 - 1.1 (0.024 - 0.043)	0.2 (0.008)
B	0.7 - 0.9 (0.028 - 0.035)	

#### AVAILABLE SNAP RINGS

##### Main drive gear bearing

Allowable clearance	0 - 0.13 mm (0 - 0.0051 in)	
Thickness mm (in)	Part number	
1.73 (0.0681)	32204-78005	
1.80 (0.0709)	32204-78000	
1.87 (0.0736)	32204-78001	
1.94 (0.0764)	32204-78002	
2.01 (0.0791)	32204-78003	
2.08 (0.0819)	32204-78004	

##### Mainshaft front

Allowable clearance	0 - 0.18 mm (0 - 0.0071 in)	
Thickness mm (in)	Part number	
2.4 (0.094)	32263-V5200	
2.5 (0.098)	32263-V5201	
2.6 (0.102)	32263-V5202	

##### OD mainshaft bearing

Allowable clearance	0 - 0.14 mm (0 - 0.0055 in)	
Thickness mm (in)	Part number	
1.1 (0.043)	32228-20100	
1.2 (0.047)	32228-20101	
1.3 (0.051)	32228-20102	
1.4 (0.055)	32228-20103	

##### Counter drive gear

Allowable clearance	0 - 0.13 mm (0 - 0.0051 in)	
Thickness mm (in)	Part number	
1.4 (0.055)	32215-E9000	
1.5 (0.059)	32215-E9001	
1.6 (0.063)	32215-E9002	

## SERVICE DATA AND SPECIFICATIONS (SDS)

### Inspection and Adjustment (Cont'd)

#### AVAILABLE SHIMS

#### Counter front bearing

Unit: mm (in)

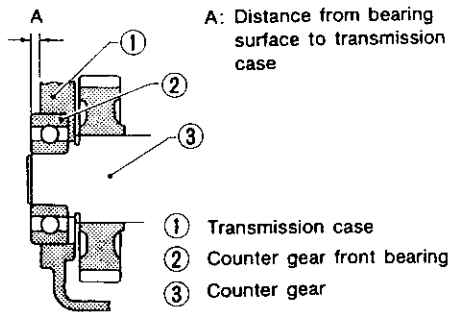

TM371

Allowable clearance	0 - 0.16 (0 - 0.0063)	
"A"	Thickness of shim	Part number
4.52 - 4.71 (0.1780 - 0.1854)	Not necessary	
4.42 - 4.51 (0.1740 - 0.1776)	0.1 (0.004)	32218-V5000
4.32 - 4.41 (0.1701 - 0.1736)	0.2 (0.008)	32218-V5001
4.22 - 4.31 (0.1661 - 0.1697)	0.3 (0.012)	32218-V5002
4.12 - 4.21 (0.1622 - 0.1657)	0.4 (0.016)	32218-V5003
4.02 - 4.11 (0.1583 - 0.1618)	0.5 (0.020)	32218-V5004
3.92 - 4.01 (0.1543 - 0.1579)	0.6 (0.024)	32218-V5005

GI

MA

EM

LC

EC

FE

CL

**MT**

AT

PD

FA

RA

BR

ST

RS

BT

HA

EL

DX

# PROPELLER SHAFT & DIFFERENTIAL CARRIER

## SECTION **PD**

### CONTENTS

<b>PREPARATION</b> .....	2	Pre-inspection .....	13
Special Service Tools.....	2	Differential Carrier .....	13
Commercial Service Tool .....	4	Differential Case .....	15
<b>PROPELLER SHAFT</b>			
<b>PROPELLER SHAFT</b> .....	5	<b>INSPECTION</b> .....	16
On-vehicle Service.....	6	Ring Gear and Drive Pinion.....	16
Removal.....	6	Bearing.....	16
Installation.....	6	Differential Case Assembly.....	16
Inspection.....	7	<b>ADJUSTMENT</b> .....	17
Disassembly.....	8	Drive Pinion Height.....	17
Assembly.....	8	Side Bearing Preload .....	19
<b>FINAL DRIVE</b>			
<b>ON-VEHICLE SERVICE/REMOVAL AND INSTALLATION</b> .....	9	Tooth Contact.....	23
Front Oil Seal Replacement.....	9	<b>ASSEMBLY</b> .....	24
Side Oil Seal Replacement.....	9	Differential Case .....	24
Removal.....	10	Differential Carrier .....	25
Installation.....	11	<b>DIFFERENTIAL OIL COOLER SYSTEM</b> .....	29
<b>FINAL DRIVE</b> .....	12	Description.....	29
<b>DISASSEMBLY</b> .....	13	Removal and Installation.....	29
		Wiring Diagram.....	30
		Inspection.....	32
		Trouble Diagnoses.....	32
		<b>SERVICE DATA AND SPECIFICATIONS (SDS)</b> .....	35
		Propeller Shaft.....	35
		Final Drive.....	35

When you read wiring diagrams:

- Read GI section, "HOW TO READ WIRING DIAGRAMS".
- See EL section, "POWER SUPPLY ROUTING" for power distribution circuit.

When you perform trouble diagnoses, read GI section, "HOW TO FOLLOW FLOW CHART IN TROUBLE DIAGNOSIS" and "HOW TO PERFORM EFFICIENT DIAGNOSIS FOR AN ELECTRICAL INCIDENT".



.





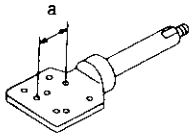
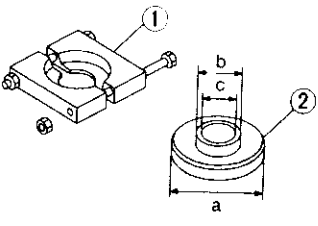
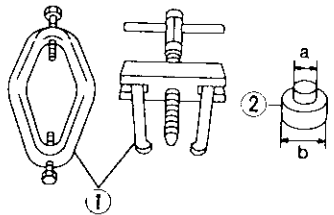
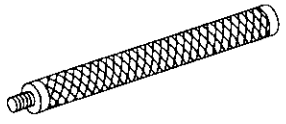
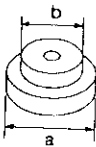
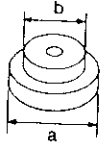

# PREPARATION

## Special Service Tools

Tool number Tool name	Description
KV38100800 Differential attachment	 <p style="text-align: right;">Mounting final drive (To use, make a new hole.)</p> <p style="text-align: center;">NT119</p> <p style="text-align: right;"><b>a: 152 mm (5.98 in)</b></p>
ST3090S000 Drive pinion rear inner race puller set ① ST30031000 Puller ② ST30901000 Base	 <p style="text-align: right;">Removing and installing drive pinion rear cone</p> <p style="text-align: center;">NT527</p> <p style="text-align: right;"><b>a: 79 mm (3.11 in) dia.</b> <b>b: 45 mm (1.77 in) dia.</b> <b>c: 35 mm (1.38 in) dia.</b></p>
ST3306S001 Differential side bearing puller set ① ST3305S001 Body ② ST33061000 Adapter	 <p style="text-align: right;">Removing and installing differential side bearing inner cone</p> <p style="text-align: center;">NT072</p> <p style="text-align: right;"><b>a: 28.5 mm (1.122 in) dia.</b> <b>b: 38 mm (1.50 in) dia.</b></p>
ST30611000 Drift	 <p style="text-align: right;">Installing pinion rear bearing outer race</p> <p style="text-align: center;">NT090</p>
ST30613000 Drift	 <p style="text-align: right;">Installing pinion front bearing outer race</p> <p style="text-align: center;">NT073</p> <p style="text-align: right;"><b>a: 72 mm (2.83 in) dia.</b> <b>b: 48 mm (1.89 in) dia.</b></p>
ST30621000 Drift	 <p style="text-align: right;">Installing pinion rear bearing outer race</p> <p style="text-align: center;">NT073</p> <p style="text-align: right;"><b>a: 79 mm (3.11 in) dia.</b> <b>b: 59 mm (2.32 in) dia.</b></p>

## PREPARATION

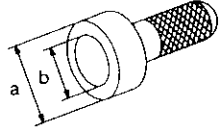
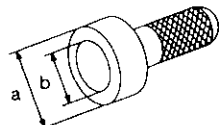
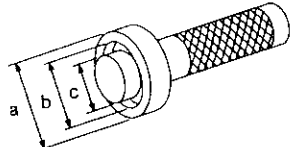
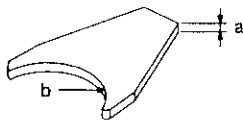
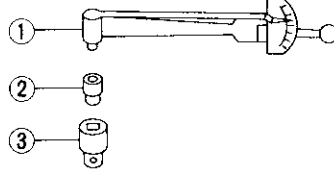
### Special Service Tools (Cont'd)

Tool number Tool name	Description
KV38100200 Gear carrier side oil seal drift	<div style="display: flex; justify-content: space-between;"> <div style="text-align: center;">  </div> <div> <p>Installing side oil seal</p> <p>a: 65 mm (2.56 in) dia. b: 49 mm (1.93 in) dia.</p> </div> </div> <p>NT115</p>
KV38100500 Gear carrier front oil seal drift	<div style="display: flex; justify-content: space-between;"> <div style="text-align: center;">  </div> <div> <p>Installing front oil seal</p> <p>a: 85 mm (3.35 in) dia. b: 60 mm (2.36 in) dia.</p> </div> </div> <p>NT115</p>
KV38100300 Differential side bearing inner cone	<div style="display: flex; justify-content: space-between;"> <div style="text-align: center;">  </div> <div> <p>Installing side bearing inner cone</p> <p>a: 54 mm (2.13 in) dia. b: 46 mm (1.81 in) dia. c: 32 mm (1.26 in) dia.</p> </div> </div> <p>NT085</p>
KV38100600 Side bearing spacer drift	<div style="display: flex; justify-content: space-between;"> <div style="text-align: center;">  </div> <div> <p>Installing side bearing spacer</p> <p>a: 8 mm (0.31 in) b: R42.5 mm (1.673 in)</p> </div> </div> <p>NT528</p>
ST3127S000 Preload gauge ① GG91030000 Torque wrench ② HT62940000 Socket adapter ③ HT62900000 Socket adapter	<div style="display: flex; justify-content: space-between;"> <div> <p>Measuring pinion bearing preload and total preload</p> </div> <div style="text-align: center;">  </div> </div> <p>NT124</p>
HT72400000 Slide hammer	<div style="display: flex; justify-content: space-between;"> <div> <p>Removing differential case assembly</p> </div> <div style="text-align: center;">  </div> </div> <p>NT125</p>

## PREPARATION

### Special Service Tools (Cont'd)

Tool number Tool name	Description
KV381039S0 Drive pinion height setting gauge ① KV38103910 Dummy shaft ② KV38100120 Height gauge ③ KV38100140 Stopper	<div style="text-align: center;"> </div> <p style="text-align: center;">NT226</p> <p style="text-align: right;">Selecting pinion height adjusting washer</p>
KV38107900 Side oil seal protector	<div style="text-align: center;"> </div> <p style="text-align: center;">NT129</p> <p style="text-align: right;">Installing final drive side flange</p>

### Commercial Service Tool

Tool name	Description
Drive pinion flange wrench	<div style="text-align: center;"> </div> <p style="text-align: center;">NT355</p> <p style="text-align: right;">Removing and installing propeller shaft lock nut, and drive pinion lock nut.</p> <p style="text-align: right;">a: 81.25 mm (3.1988 in)</p>

# PROPELLER SHAFT

SEC. 370  
3S71A

M/T model

⑧ Apply a coat of multi-purpose lithium grease containing molybdenum disulfide to the end face of the center bearing and both sides of the washer.

A/T model

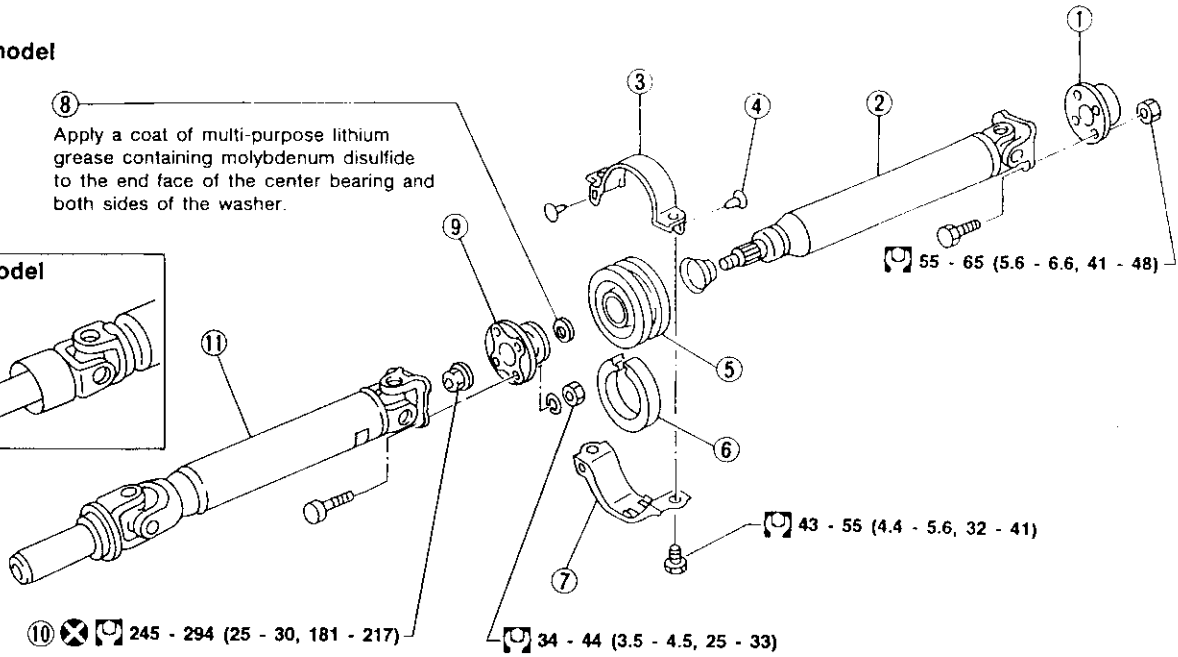
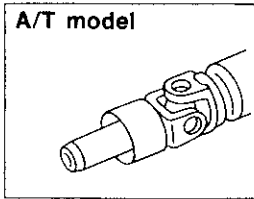

: N·m (kg-m, ft-lb)

SPD322A

- |   |   |                            |
|---|---|----------------------------|
| ① Final drive companion flange          | ⑤ Center bearing                        | ⑨ Companion flange         |
| ② Propeller shaft 2nd tube              | ⑥ Center bearing cushion                | ⑩ Lock nut                 |
| ③ Center bearing upper mounting bracket | ⑦ Center bearing lower mounting bracket | ⑪ Propeller shaft 1st tube |
| ④ Clip                                  | ⑧ Washer                                |                            |

PD

## PROPELLER SHAFT

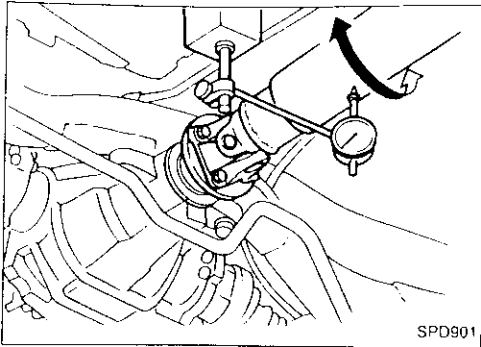

### On-vehicle Service

#### PROPELLER SHAFT VIBRATION

If vibration is present at high speed, inspect propeller shaft runout first.

1. Raise rear wheels.
2. Measure propeller shaft runout at indicated points by rotating final drive companion flange with hands.

**Runout limit: 0.6 mm (0.024 in)**

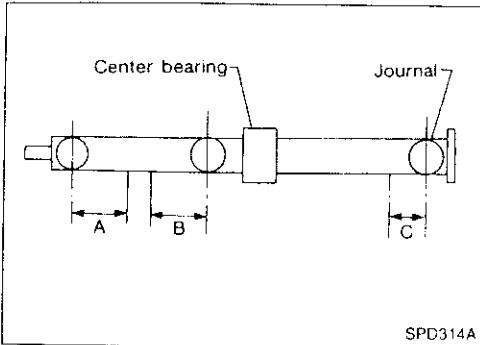

#### Propeller shaft runout measuring points:

**Distance:**

**"A" 155 mm (6.10 in)**

**"B" 165 mm (6.50 in)**

**"C" 185 mm (7.28 in)**

3. If runout exceeds specifications, disconnect propeller shaft at final drive companion flange. Then rotate companion flange 90, 180 or 270 degrees and reconnect propeller shaft.

**Runout limit: 0.6 mm (0.024 in)**

4. Check runout again. If runout still exceeds specifications, replace propeller shaft assembly.
5. Perform road test.

#### APPEARANCE CHECKING

- Inspect propeller shaft tube surface for dents or cracks. If damaged, replace propeller shaft assembly.
- If center bearing is noisy or damaged, replace it.

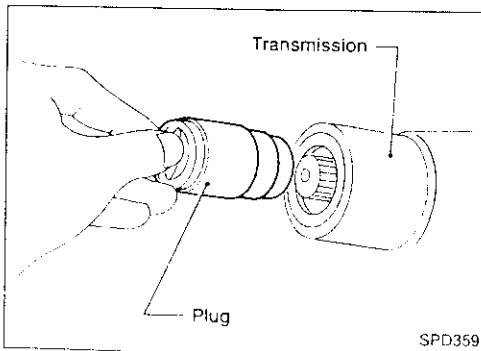
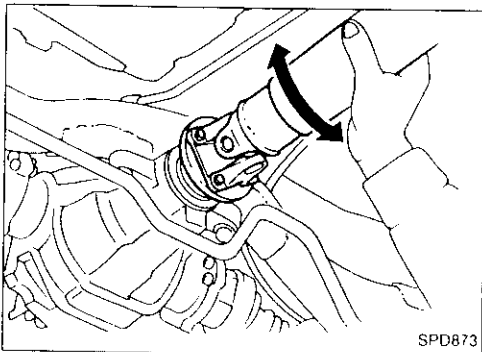

#### Removal

- Draw out propeller shaft from transmission and plug up rear end of transmission rear extension housing.

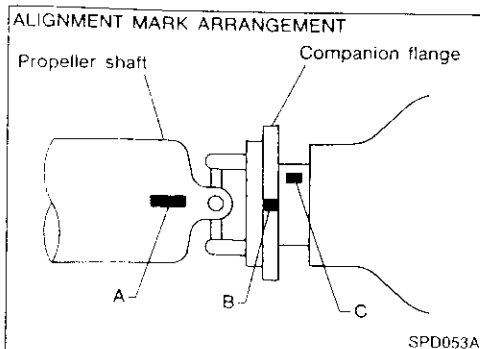

#### Installation

If companion flange has been removed, put new alignment marks B and C on it. Then reassemble using the following procedure. Perform step 4 when final drive and propeller shaft are separated from each other. Also perform step 4 when either of these parts is replaced with a new one.

## PROPELLER SHAFT

### Installation (Cont'd)

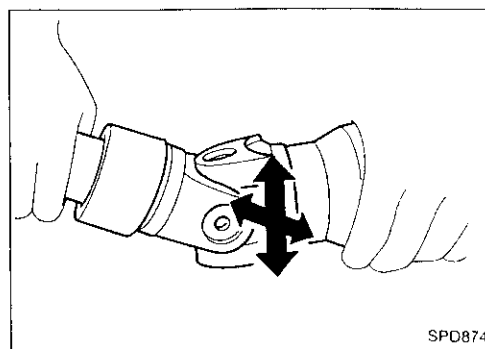
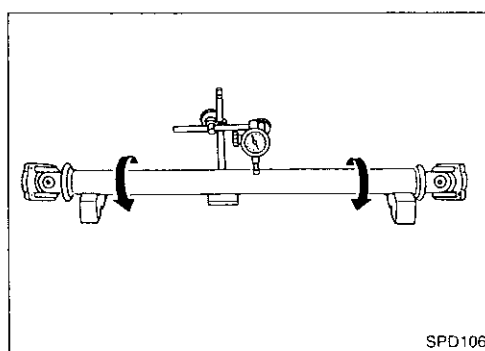
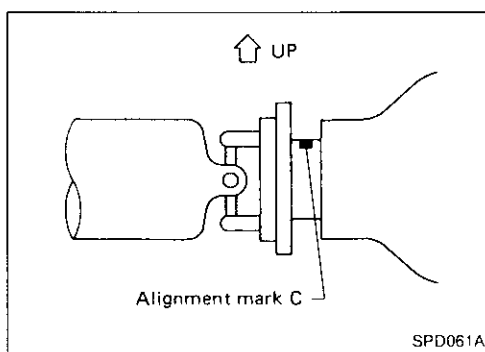
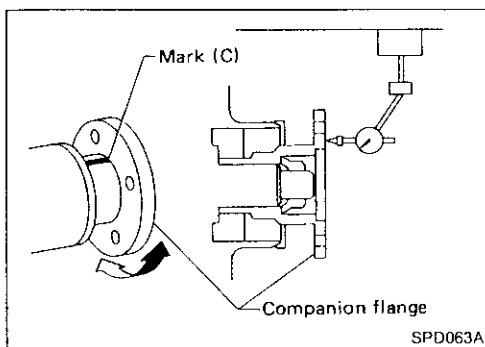
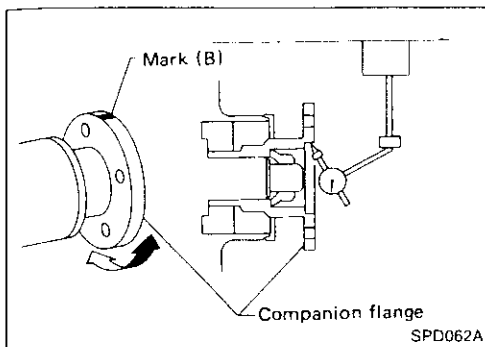

1. Erase original marks B and C from companion flange with suitable solvent.
2. Mark (B)
  - A. Measure companion flange vertical runout.
  - B. Determine the position where maximum runout is read on dial gauge. Put mark (shown by B in figure at left) on flange perimeter corresponding to maximum runout position.
3. Mark (C)
  - A. Measure companion flange surface runout.
  - B. Determine the position where maximum runout is read on dial gauge. Put mark (shown by C in figure at left) on flange perimeter corresponding to maximum runout position.
4. Position companion flange and propeller shaft using alignment marks A and B. Set the marks A and B as close to each other as possible. Temporarily attach bolts and nuts.
5. Press down propeller shaft with alignment mark C facing upward. Then tighten the lower nut to specified torque.
6. Tighten remaining nuts to specified torque.

### Inspection

- Inspect propeller shaft runout. If runout exceeds specifications, replace propeller shaft assembly.  
**Runout limit: 0.6 mm (0.024 in)**
- Inspect journal axial play. If the play exceeds specifications, replace propeller shaft assembly.  
**Journal axial play:  
0 mm (0 in)**

## ON-VEHICLE SERVICE/REMOVAL AND INSTALLATION

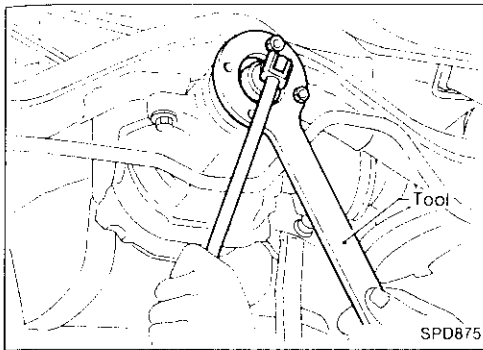

### Front Oil Seal Replacement

1. Remove propeller shaft.
2. Loosen drive pinion nut with suitable tool.

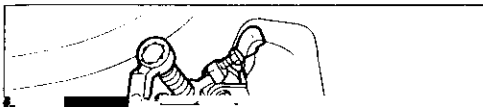

3. Remove companion flange.

## PROPELLER SHAFT

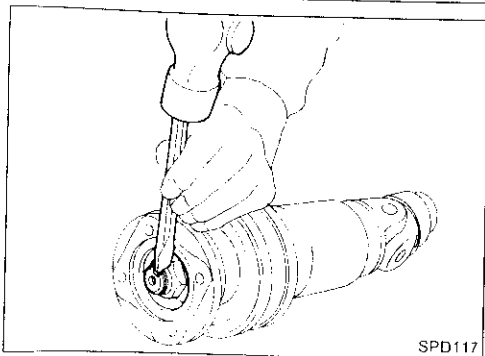
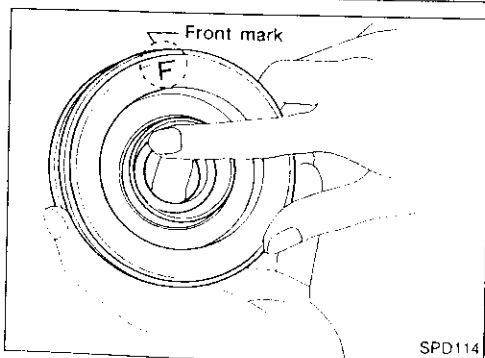
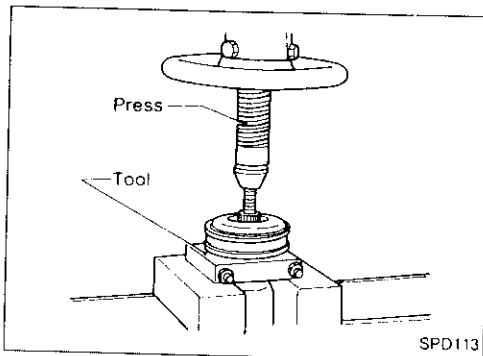
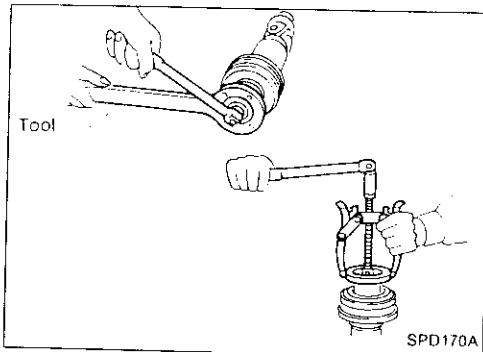
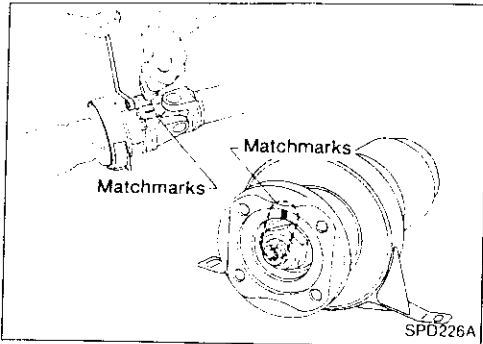

### Disassembly

#### CENTER BEARING

1. Put matchmarks on flanges, and separate 2nd tube from 1st tube.
2. Put matchmarks on the flange and shaft.
3. Remove locking nut with suitable tool.
4. Remove companion flange with puller.
5. Remove center bearing with Tool and press.  
**Tool number: ST30031000**

### Assembly

#### CENTER BEARING

- When installing center bearing, position the "F" mark on center bearing toward rear of vehicle.
  - **Apply a coat of grease to the end face of center bearing and both sides of washer.**  
Use multi-purpose lithium grease that contains molybdenum disulfide.
- 
- Stake the nut. Always use new one.
  - Align matchmarks when assembling tubes.



## ON-VEHICLE SERVICE/REMOVAL AND INSTALLATION

### Side Oil Seal Replacement (Cont'd)

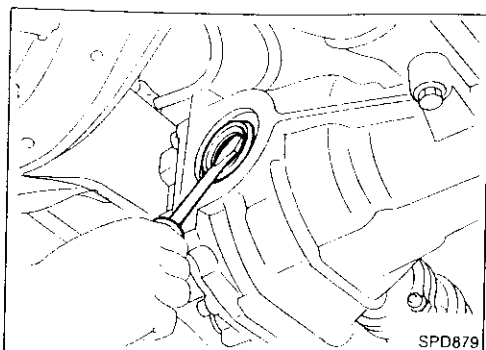

3. Remove oil seal.

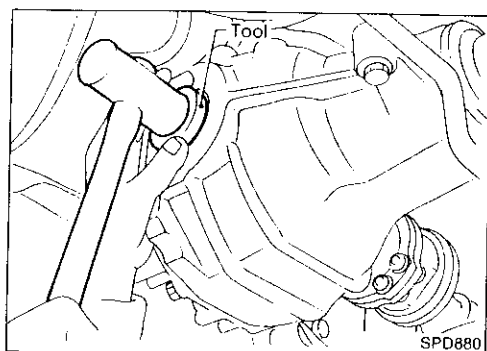

4. Apply multi-purpose grease to sealing lips of oil seal. Press-fit oil seal into carrier with Tool.

**Tool number: KV38100200**

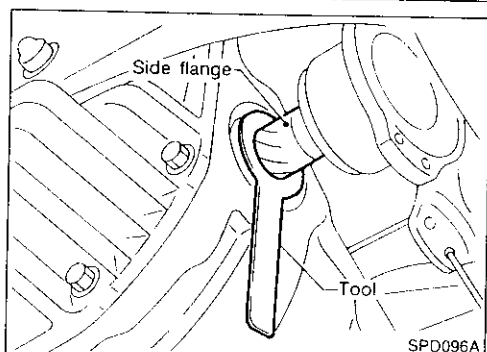

5. Install final drive side flange.

**Use Tool to prevent side oil seal from being damaged by spline portion of side flange.**

**Tool number: KV38107900**

6. Install drive shaft.

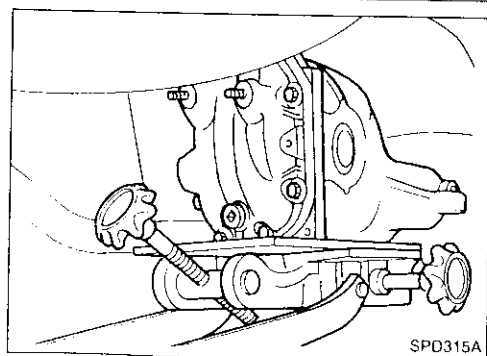

### Removal

#### CAUTION:

**Before removing the final drive assembly, disconnect the ABS sensor from the assembly. Then move it away from the final drive assembly. Failure to do so may result in damage to the sensor wires and the sensor becoming inoperative.**

- Remove propeller shaft.
- **Plug up rear end of transmission rear extension housing.**
- Remove drive shafts.  
Refer to "Drive Shaft" of "REAR AXLE" in RA section.
- Remove nuts securing final drive rear cove to suspension member.
- Support weight of final drive using jack.
- Remove final drive mounting member from front of final drive.
- Move final drive forward together with jack. Remove rear cover stud bolts from suspension member.
- Lower final drive using jack. Remove jack from rear of vehicle.

## ON-VEHICLE SERVICE/REMOVAL AND INSTALLATION

### Removal (Cont'd)

#### CAUTION:

- Be careful not to damage spline, sleeve yoke and front oil seal, when removing propeller shaft.
- After removal, support suspension member on a stand to prevent its insulators from being twisted or damaged.

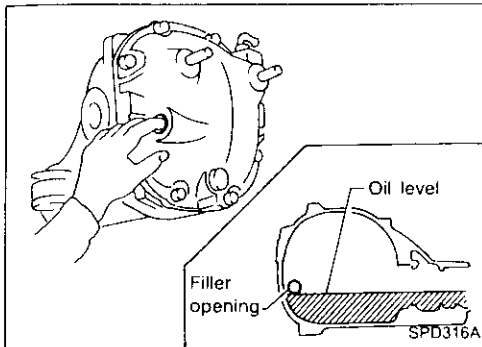

### Installation

- Fill final drive with recommended gear oil.
- **Models equipped with oil cooler system** —
- Check oil level and for oil leakage from hoses after oil cooler has been operated.

## DISASSEMBLY

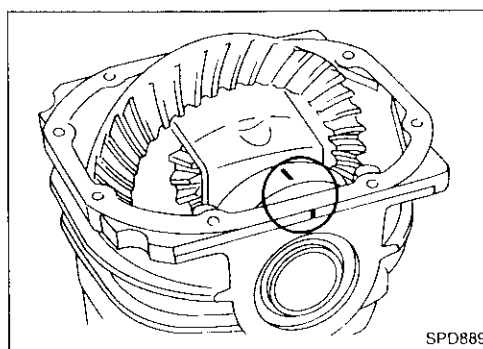
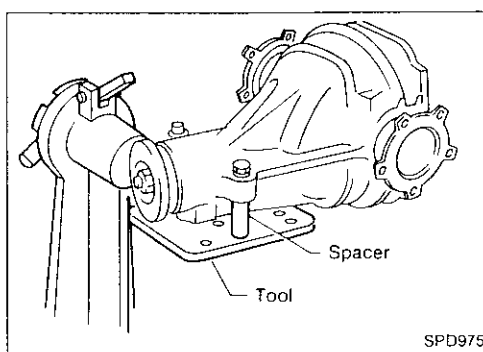
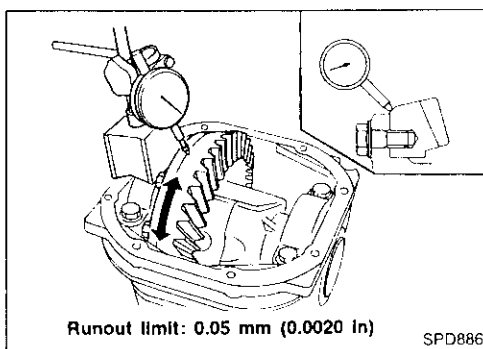
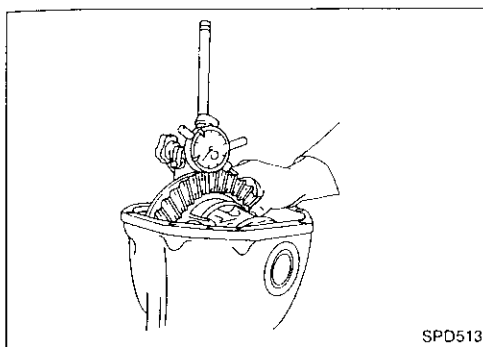
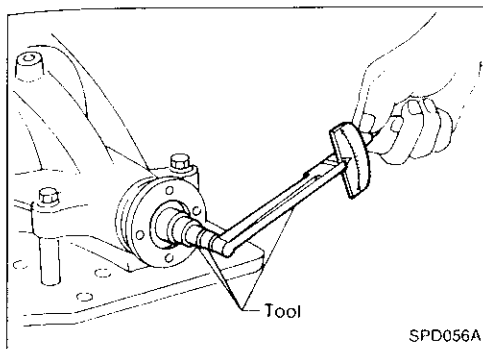

### Pre-inspection

Before disassembling final drive, perform the following inspection.

- Total preload
  - 1) Turn drive pinion in both directions several times to set bearing rollers.
  - 2) Check total preload with Tool.

**Tool number: ST3127S000**

**Total preload:**

**1.4 - 3.1 N·m (14 - 32 kg-cm, 12 - 28 in-lb)**

- Ring gear to drive pinion backlash  
Check ring gear-to-drive pinion backlash with a dial indicator at several points.

**Ring gear-to-drive pinion backlash:**

**0.10 - 0.15 mm (0.0039 - 0.0059 in)**

- Ring gear runout  
Check runout of ring gear with a dial indicator.  
**Runout limit: 0.05 mm (0.0020 in)**
- Tooth contact  
Check tooth contact. Refer to Adjustment (PD-23).

### Differential Carrier

1. Using two 45 mm (1.77 in) spacers, mount carrier on Tool.  
**Tool number: KV38100800**

2. For proper reinstallation, paint or punch matchmarks on one side of the side bearing cap.

**Bearing caps are line-board during manufacture. Replace them in their proper positions.**

PD

# FINAL DRIVE

R200V

SEC. 380

Models with differential oil cooler system

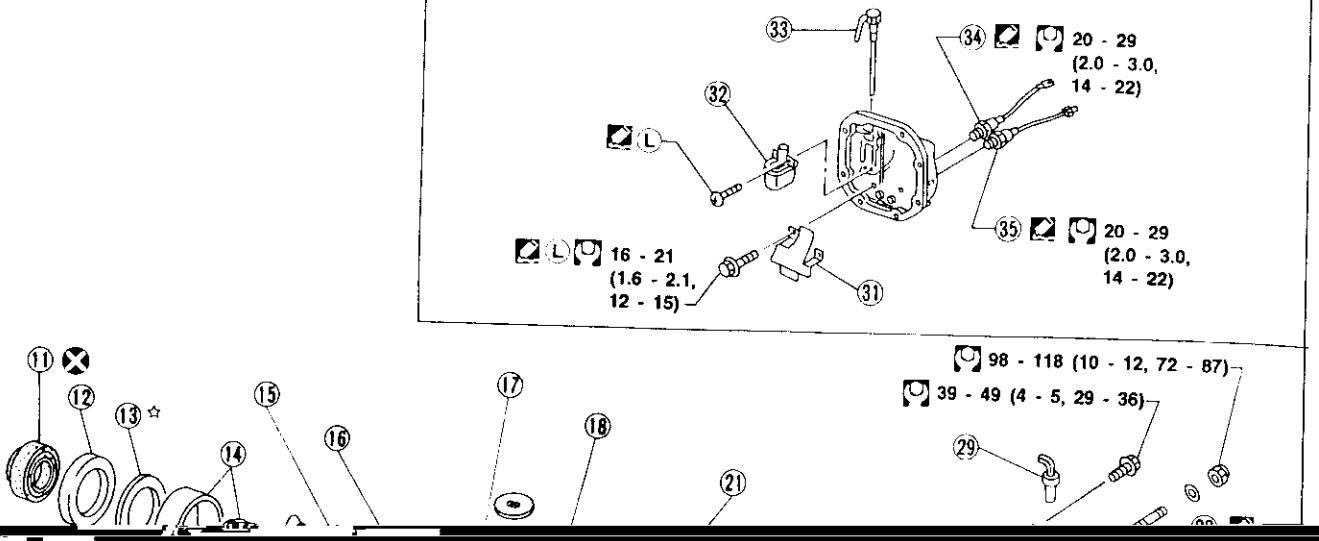

## DISASSEMBLY

### Differential Carrier (Cont'd)

3. Remove side bearing caps.

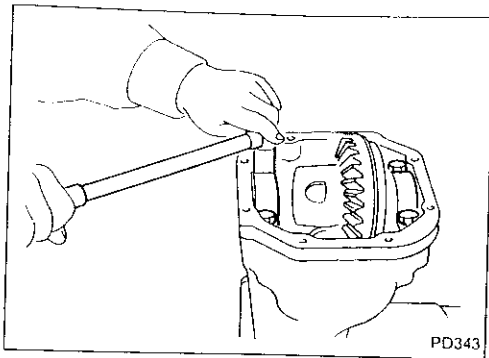

4. Lift differential case assembly out with Tool.  
Tool number: HT72400000

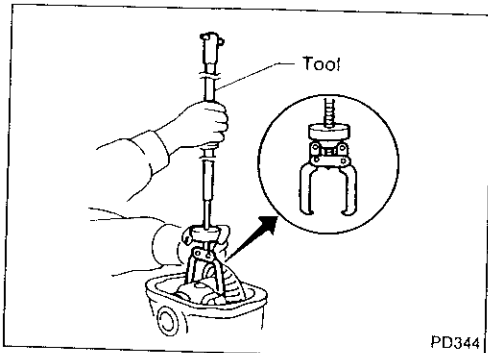

Keep the side bearing outer races together with inner cone — do not mix them up.  
Also, keep side bearing spacer and adjusting shims together with bearings.

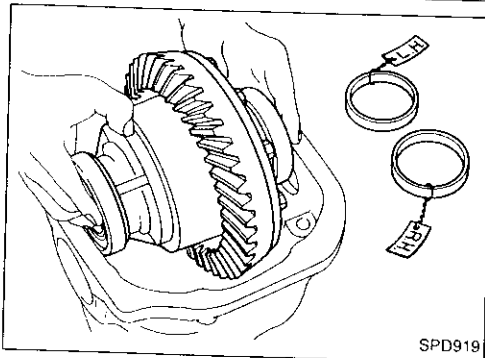

5. Loosen drive pinion nut and pull off companion flange.

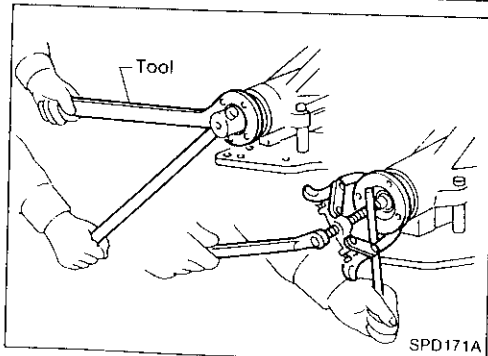

6. Take out drive pinion (together with rear bearing inner race, bearing spacer and adjusting washer).  
7. Remove oil seal.  
8. Remove front bearing inner race.  
9. Remove side oil seal.

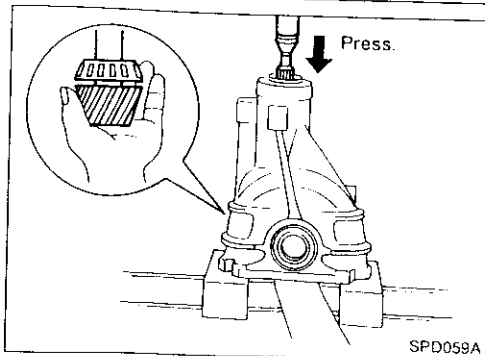

## DISASSEMBLY

### Differential Carrier (Cont'd)

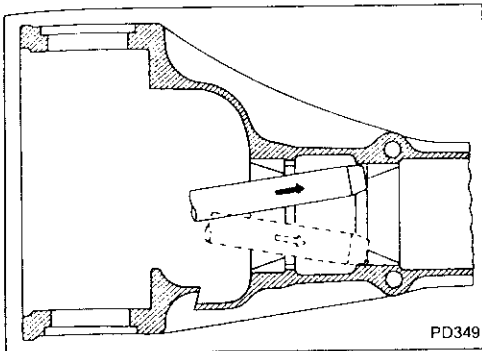

10. Remove pinion bearing outer races with a brass drift.

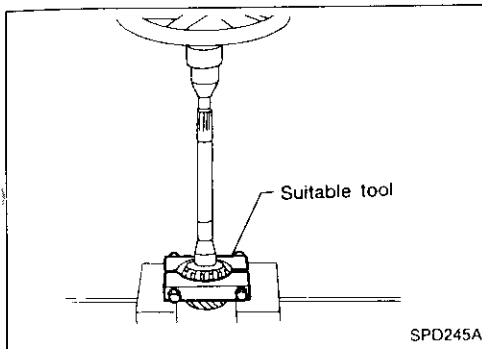

11. Remove pinion rear bearing inner race and drive pinion height adjusting washer with suitable tool.

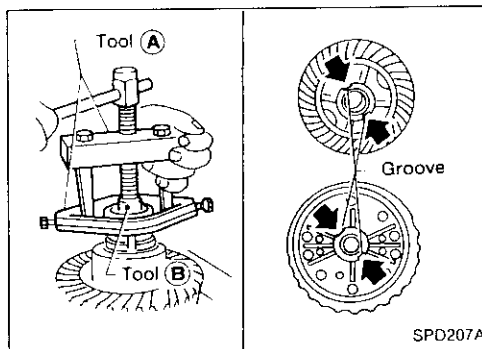

### Differential Case

1. Remove side bearing inner cones.

**To prevent damage to bearing, engage puller jaws in groove.**

**Tool number:**

**(A) ST3305S001**

**(B) ST33061000**

**Be careful not to confuse left- and right-hand parts. Keep bearing and bearing race for each side together.**

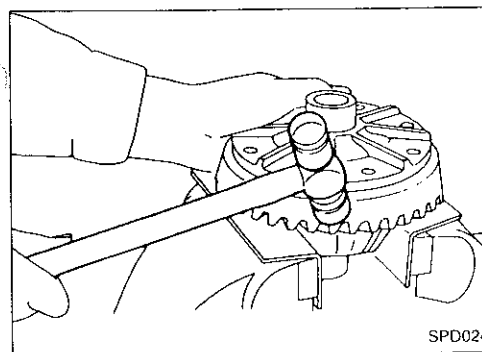

2. Loosen ring gear bolts in a criss-cross fashion.

3. Tap ring gear off the differential case with a soft hammer.

**Tap evenly all around to keep ring gear from binding.**

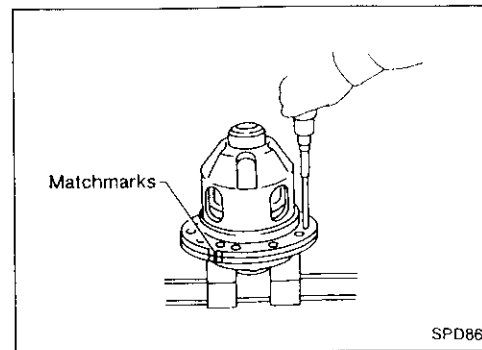

4. Loosen screws on differential cases A and B.

5. Separate differential cases A and B.

21  
22  
23  
24  
25  
26  
27  
28  
29  
30  
31  
32  
33  
34  
35  
36  
37  
38  
39  
40  
41  
42  
43  
44  
45  
46  
47  
48  
49  
50  
51  
52  
53  
54  
55  
56  
57  
58  
59  
60  
61  
62  
63  
64  
65  
66  
67  
68  
69  
70  
71  
72  
73  
74  
75  
76  
77  
78  
79  
80  
81  
82  
83  
84  
85  
86  
87  
88  
89  
90  
91  
92  
93  
94  
95  
96  
97  
98  
99  
100

PD

## INSPECTION

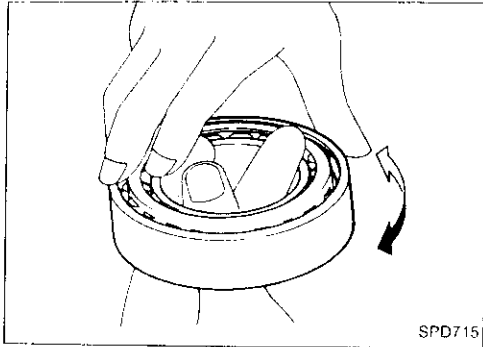

### Ring Gear and Drive Pinion

Check gear teeth for scoring, cracking or chipping. If any part is damaged, replace ring gear and drive pinion as a set (hypoid gear set).

### Bearing

1. Thoroughly clean bearing.
2. Check bearings for wear, scratches, pitting or flaking. Check tapered roller bearing for smooth rotation. If damaged, replace outer race and inner cone as a set.

### Differential Case Assembly

- Check mating surfaces of differential case, side gears, pinion mate gears, pinion mate shaft and thrust washers.
- Check viscous coupling for oil leakage. If necessary, replace it with new one.

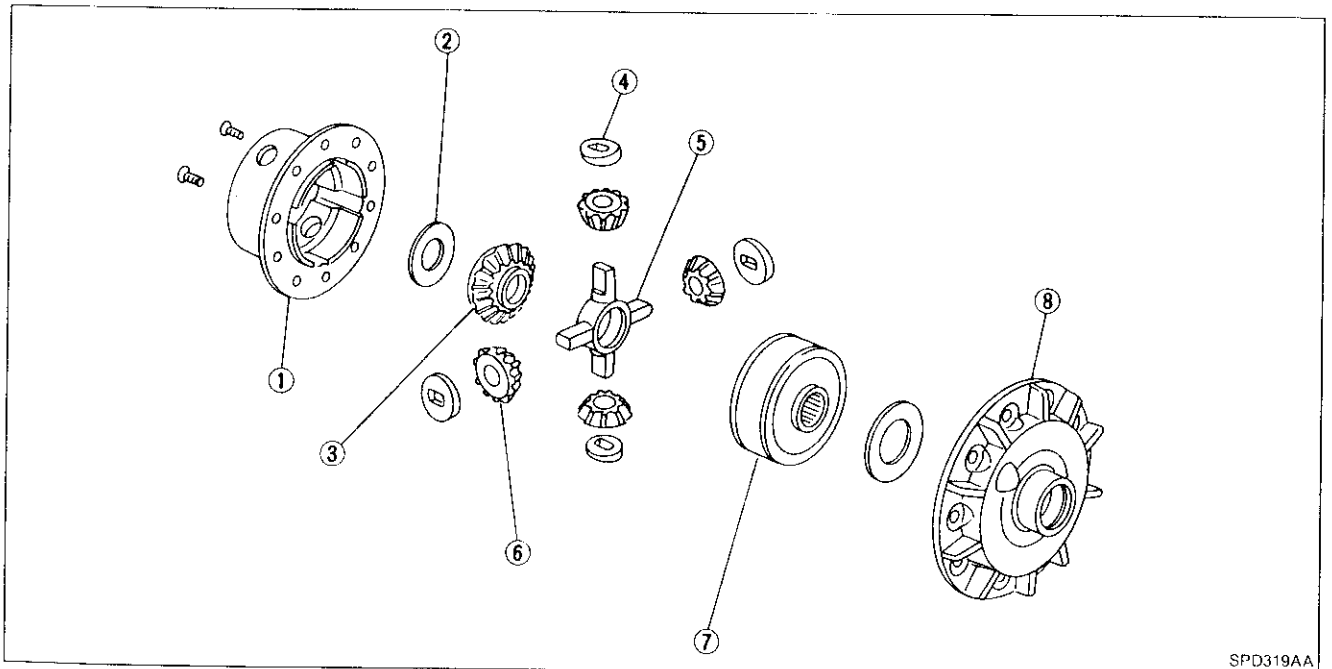

- |                           |                             |  |
|---------------------------|-----------------------------|--|
| ① Differential case B     | ④ Pinion mate thrust washer | ⑦ Side gear (LH) with viscous coupling |
| ② Side gear thrust washer | ⑤ Pinion mate shaft         | ⑧ Differential case A                  |
| ③ Side gear (RH)          | ⑥ Pinion mate gear          |  |

## ADJUSTMENT

To avoid confusion while calculating bearing shims, it is absolutely necessary to stay with the metric system. If you measure anything in inches, **the results must be converted to the metric system.**

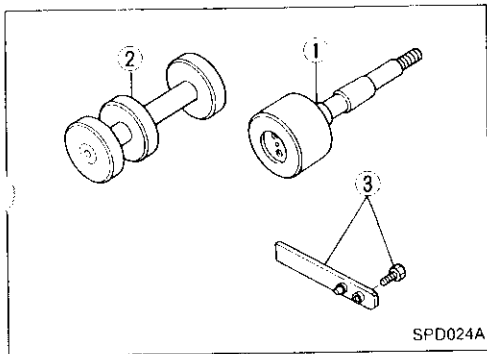

### Drive Pinion Height

1. First prepare Tools for pinion height adjustment.
  - ① Dummy shaft (KV38103910)
  - ② Height gauge (KV38100120)
  - ③ Stopper (KV38100140)
2. To simplify the job, make a chart, like the one below, to organize your calculations.

LETTERS	HUNDREDTHS OF A MILLIMETER
H: Head number	
N: Measuring clearance	

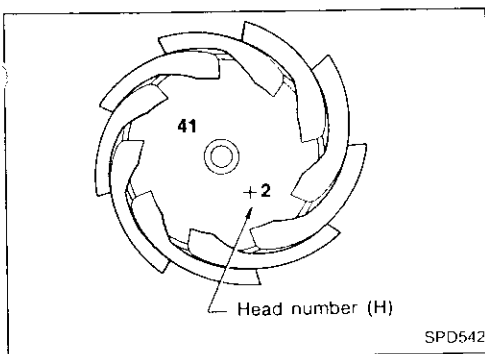

3. Write the following numbers down the chart.
  - H: Head number

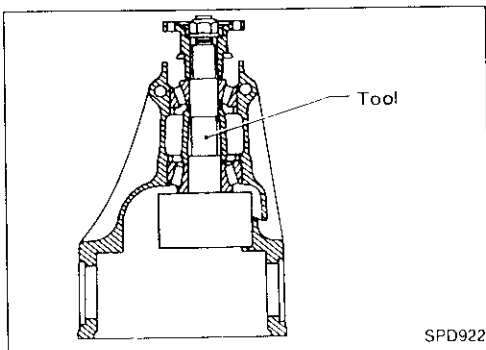

4. Set Tool (Dummy shaft) as shown below and tighten drive pinion nut carefully to correct preload of 1.0 to 1.3 N·m (10 to 13 kg-cm, 8.7 to 11.3 in-lb).
 

**Tool number: KV38103910**



## ADJUSTMENT

### Drive Pinion Height (Cont'd)

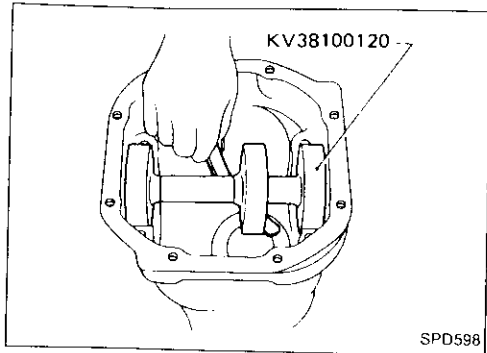

5. Attach Tool (Height gauge) to gear carrier, and measure the clearance between the height gauge and the dummy shaft face.
6. Substitute these values into the equation to calculate the thickness of the washer.

**If value signifying H is not given, regard it as zero and calculate.**

$$T \text{ (Thickness of washer)} = N - (H \times 0.01) + 3.00$$

Example:

$$N = 0.23$$

$$H = 1$$

$$\begin{aligned} T &= N - (H \times 0.01) + 3.00 \\ &= 0.23 - (1 \times 0.01) + 3.00 \end{aligned}$$

(1)	H .....	1
		+1
(2)		+1
		<u>x 0.01</u>
		+ 0.01
(3)	N .....	0.23
		<u>- (+0.01)</u>
		0.22
(4)		0.22
		<u>+ 3.00</u>
		3.22
		∴ T = 3.22

7. Select the proper pinion height washer.

**Drive pinion height adjusting washer:**

**Refer to SDS (PD-36).**

**If you cannot find the desired thickness of washer, use washer with thickness closest to the calculated value.**

Example:

Calculated value ... T = 3.22 mm

Used washer ... T = 3.21 mm

## ADJUSTMENT

### Drive Pinion Height (Cont'd)

#### — Washer selection when replacing hypoid gear set —

Drive pinions may be different in height due to the manufacturing process. Use a washer of proper thickness to adjust the height of new drive pinion. Select the washer as follows:

$$T = (t_1 - t_2) \times 0.01 + T_0$$

where T: thickness of the washer to select

$T_0$ : thickness of the washer used

$t_1$ : old drive pinion head number

$t_2$ : new drive pinion head number

Example:

$$T_0 = 3.21, t_1 = +2, t_2 = -1$$

$$T = \{2 - (-1)\} \times 0.01 + 3.21$$

$$= 3 \times 0.01 + 3.21$$

$$= 0.03 + 3.21$$

$$= 3.24$$

$$T = 3.24 \text{ mm}$$

Drive pinion height adjusting washer:

Refer to SDS (PD-36).

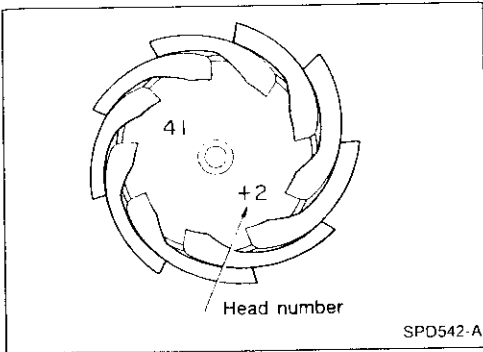

### Side Bearing Preload

- To simplify the job, make a chart like the one below to organize your calculations.

LETTERS	VALUE
A: Left housing	
B: Right housing	
C: Differential case	
D: Differential case	
H: (+) or (-): ring gear	
E: Left side bearing (= 21 - Measured height)	
F: Right side bearing (= 21 - Measured height)	
G: Side bearing spacer (= 8.1 - Measured thickness)	
X:	1.97
Y:	2.07

- Write the following numbers down in the chart. If numbers for A, B, C, D and H are not given, regard them as zero.

A & B: Figures marked on gear carrier

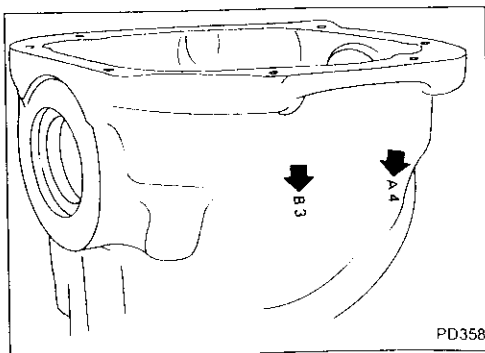

## ADJUSTMENT

### Side Bearing Preload (Cont'd)

C & D: Figures marked on differential case

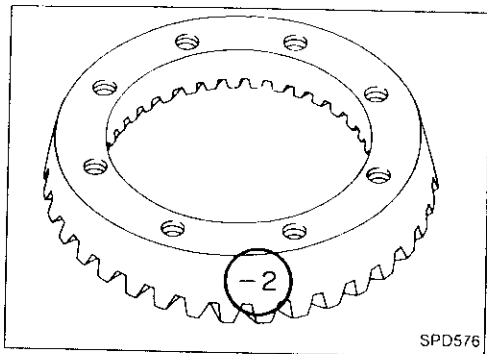
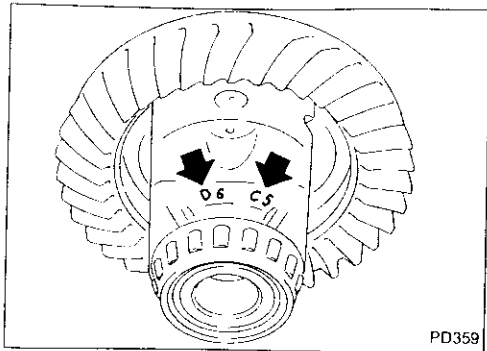

H: Figure marked on ring gear  
Do not confuse negative and positive values.

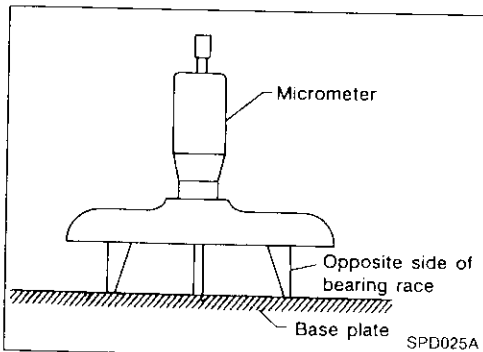

3. Calculate "E" and "F" as follows:

$E \text{ \& \& } F = 21 \text{ mm (0.83 in)}$  – Measured bearing height

Bearing height can be measured as follows:

a. Measure height of bearing race which will be used as a base for the opposite side of a side bearing assembly.

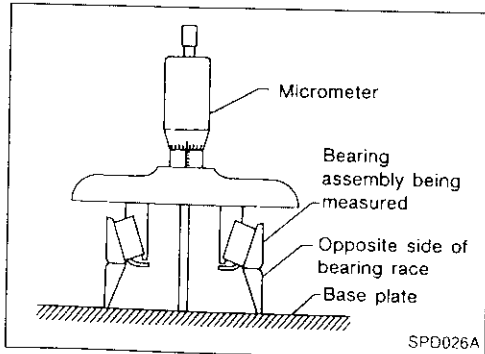

b. Set bearing assembly to be measured on the base race and measure the total height.

**Lubricate bearing assembly and turn it several times to settle it on the base for accurate measurement.**

c. Subtract base race height from total height.

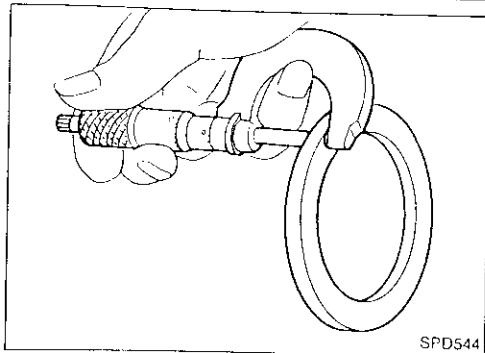

4. Calculate "G".

G: This is the difference in thickness of side spacer from standard width [8.10 mm (0.3189 in)].

$G = 8.10 \text{ mm (0.3189 in)}$  – Measured thickness

## ADJUSTMENT

### Side Bearing Preload (Cont'd)

LETTERS	VALUE
A: Left housing	
B: Right housing	
C: Differential case	
D: Differential case	
H: (+) or (-): ring gear	
E: Left side bearing (= 21 - Measured height)	
F: Right side bearing (= 21 - Measured height)	
G: Side bearing spacer (= 8.1 - measured thickness)	
X:	1.97
Y:	2.07

**Calculations:**

**Side bearing spacer is used on the right**

**Left side washer thickness**

$$T_1 = (A - C + D - H) \times 0.01 + E + Y$$

**Right side washer thickness**

$$T_2 = (B - D + H) \times 0.01 + F + G + X$$

**Side bearing spacer is used on the left**

**Left side washer thickness**

$$T_1 = (A - C + D - H) \times 0.01 + E + G + X$$

**Right side washer thickness**

$$T_2 = (B - D + H) \times 0.01 + F + Y$$

PD

## ADJUSTMENT

### Side Bearing Preload (Cont'd)

Example for R200V which has a side bearing spacer on the right:

A = 4	E = 0.18
B = 3	F = 0.15
C = 5	G = 0.08
D = 6	X = 1.97
H = -2	Y = 2.07

**Left side washer thickness (without spacer)**

$$T_1 = (A - C + D - H) \times 0.01 + E + Y$$

4	A	
- 5	- C	
= -1		
+ 6	+ D	
= 5		
- (-2)	- H	
= 7		
x 0.01	x 0.01	
= 0.07		
+ 0.18	+ E	
= 0.25		
+ 2.07	+ Y	
= 2.32		
<b>T<sub>1</sub> = 2.32 mm</b>		

**Right side washer thickness (with spacer)**

$$T_2 = (B - D + H) \times 0.01 + F + G + X$$

3	B	
- 6	- D	
= -3		
+ (-2)	+ H	
= -5		
x 0.01	x 0.01	
= -0.05		
+ 0.15	+ F	
= 0.10		
+ 0.08	+ G	
= 0.18		
+ 1.97	+ X	
= 2.15		
<b>T<sub>2</sub> = 2.15 mm</b>		

5. Select the proper shims. Refer to SDS (PD-36).  
**If you cannot find the desired thickness of shims, use shims with the total thickness closest to the calculated value.**

## ADJUSTMENT

### Tooth Contact

Checking gear tooth contact pattern is necessary to verify correct relationship between ring gear and drive pinion. Hypoid gears which are not positioned in proper arrangement may be noisy and/or have a short life. Check gear tooth contact pattern to obtain the best contact for low noise and long life.



1. Thoroughly clean ring gear and drive pinion teeth.
2. Lightly apply a mixture of powdered titanium oxide and oil or the equivalent. Apply it to 3 or 4 teeth of ring gear drive side.

## ASSEMBLY

### Differential Case

Whenever side gears or pinion mate gears are replaced, selection of thrust washers should be carried out.

Before selecting thrust washers, make sure all parts are clean and well lubricated with hypoid gear oil.

#### THRUST WASHER SELECTION

1. Install the previously removed thrust washer on right side gear. On left side gear, install a suitable thrust washer. Temporarily tighten differential cases using two screws.
  2. Position differential assembly so that right side gear is on the upper side. Place two feeler gauges of 0.03 mm (0.0012 in) thickness between right side gear and thrust washer as shown.
- Do not insert feeler gauge in oil groove portion of differential case.**
3. Rotate right side gear with a suitable tool attached to splines. If hard to rotate, replace thrust washer on left side gear with a thinner one.
  4. Replace both 0.03 mm (0.0012 in) feeler gauges with 0.10 mm (0.0039 in) gauges. At this point, make sure right side gear does not rotate. If it rotates, replace thrust washer on left side gear with a thicker one to prevent rotation.

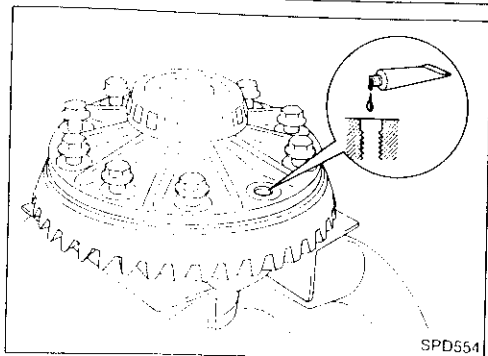
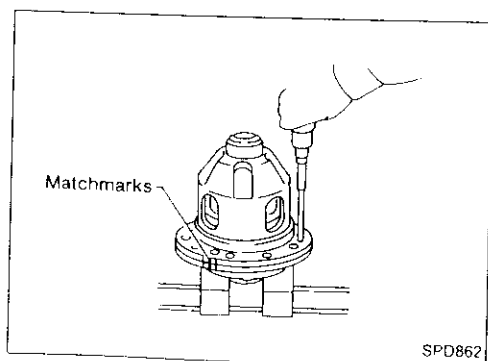
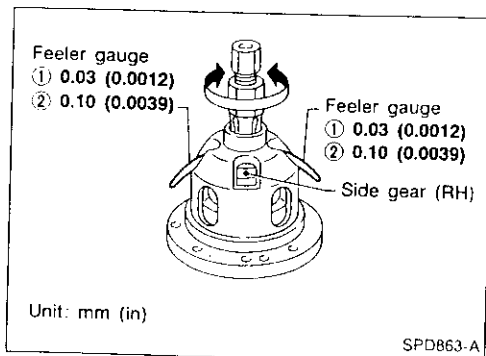

### ASSEMBLY

1. Install differential case A and B.
2. Place differential case on ring gear.
3. Apply locking sealant to ring gear bolts, and install them. **Tighten bolts in a criss-cross fashion, lightly tapping bolt head with a hammer.**

## ASSEMBLY

### Differential Case (Cont'd)

4. Press-fit side bearing inner cones on differential case with Tool.

Tool number:

- (A) KV38100300
- (B) ST33061000

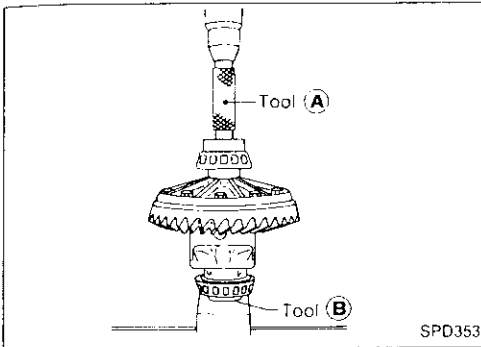

### Differential Carrier

1. Press-fit front and rear bearing outer races with Tools.

Tool number:

- (A) ST30611000
- (B) ST30621000
- (C) ST30613000

2. Select pinion bearing adjusting washer and drive pinion bearing spacer. Refer to ADJUSTMENT (PD-17).

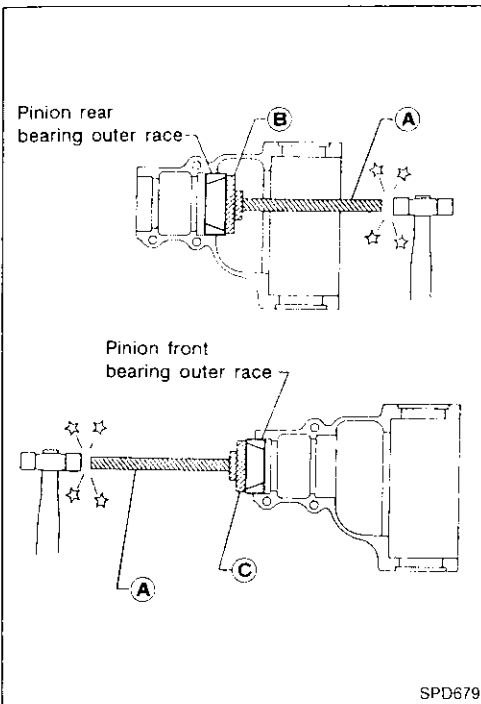

3. Install selected drive pinion height adjusting washer in drive pinion. Using press and Tool, press-fit pinion rear bearing inner cone into it.

Tool number: ST30901000

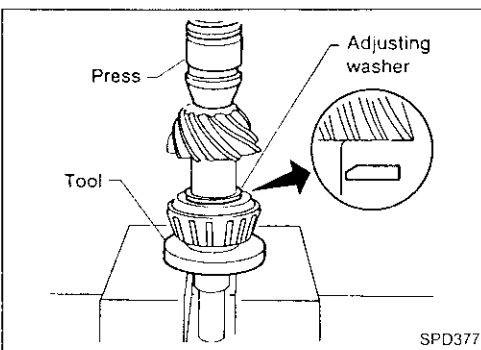

4. Place pinion front bearing inner cone in final drive housing.

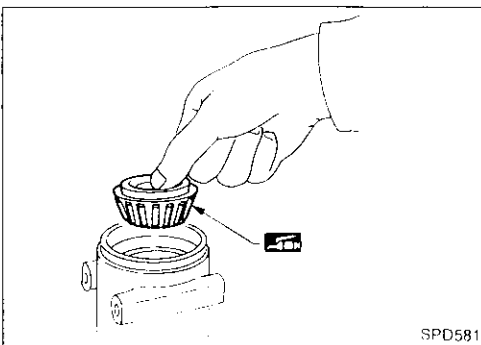



## ASSEMBLY

### Differential Carrier (Cont'd)

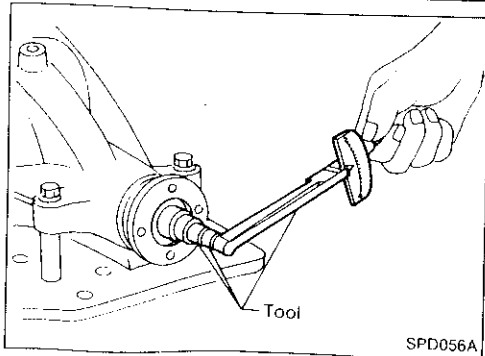
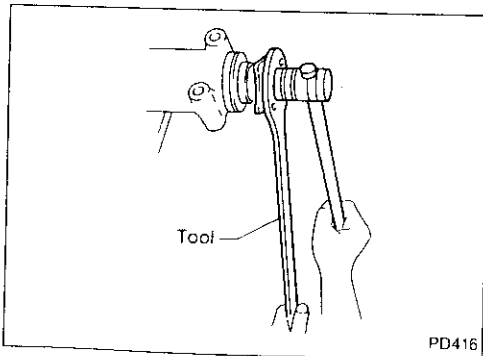
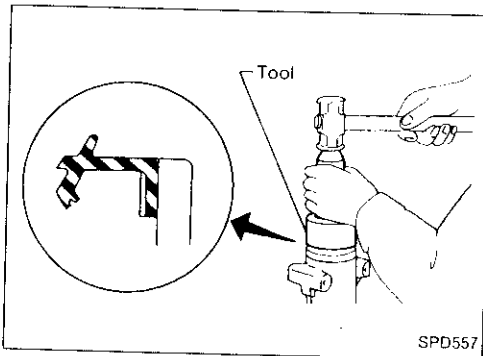
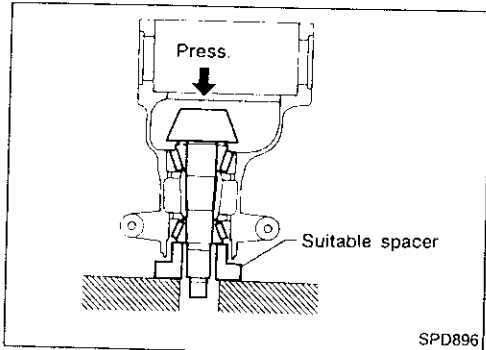
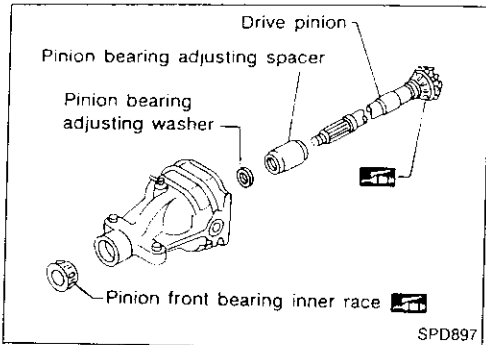

5. Set drive pinion assembly (as shown in figure at left) in differential carrier and install drive pinion, with press and suitable tool.

**Stop when drive pinion touches bearing.**

**Apply multi-purpose grease to pinion rear bearing inner race, pinion front bearing inner race.**

6. Apply multi-purpose grease to cavity at sealing lips of oil seal. Install front oil seal with Tool.

**Tool number: KV38100500**

7. Install companion flange, and tighten pinion nut to specified torque with suitable tool.

**Make sure that threaded portion of drive pinion and pinion nut are free from oil or grease.**

8. Turn drive pinion in both directions several times, and measure pinion bearing preload.

**Pinion bearing preload:**

**1.1 - 1.4 N·m (11 - 14 kg-cm, 9.5 - 12.2 in-lb)**

**When pinion bearing preload is outside specifications, replacement is required for pinion bearing adjusting washer and spacer. Replace with those of different thickness.**

## ASSEMBLY

### Differential Carrier (Cont'd)

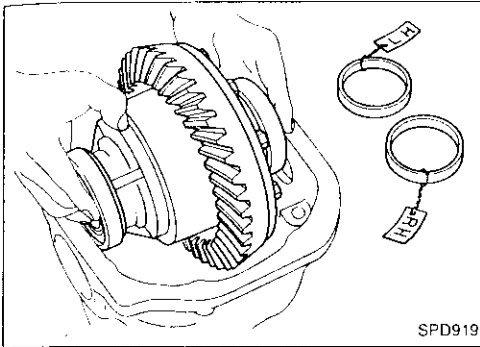

9. Select side bearing adjusting washer. Refer to ADJUSTMENT (PD-19).
10. Install differential case assembly with side bearing outer races into gear carrier.

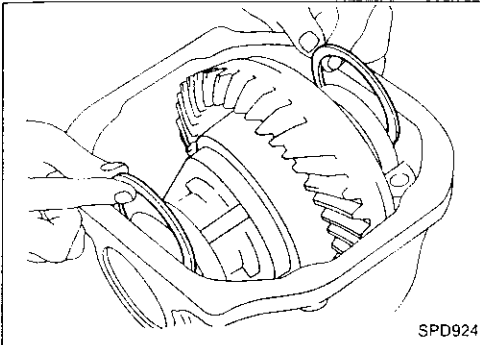

11. Insert left and right side bearing adjusting washers in place between side bearings and carrier.

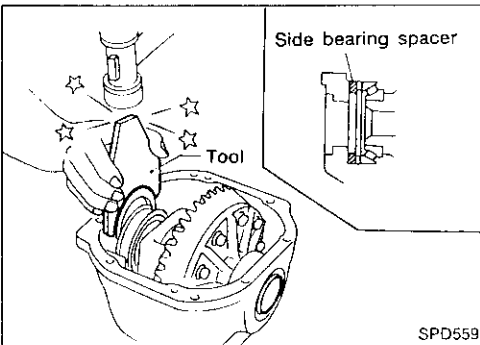

12. Drive in side bearing spacer with Tool.  
**Tool number: KV38100600**  
**Spacer location: Right side**

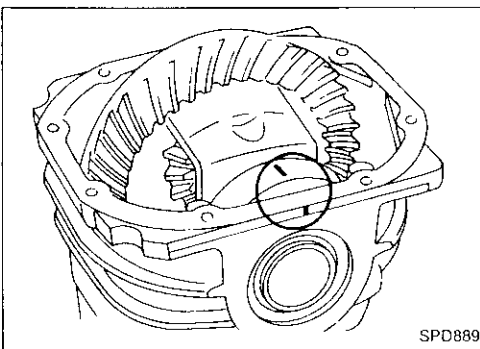

13. Align mark on bearing cap with that on gear carrier and install bearing cap on gear carrier.

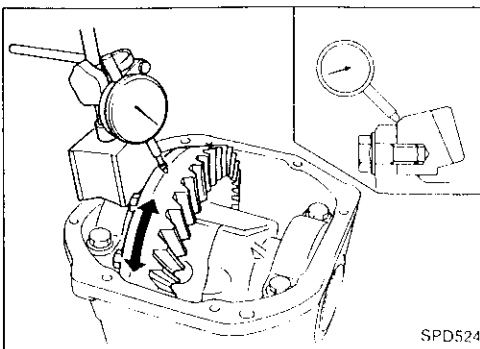

14. Check runout of ring gear with a dial indicator.  
**Runout limit: 0.05 mm (0.0020 in)**

## ASSEMBLY

### Differential Carrier (Cont'd)

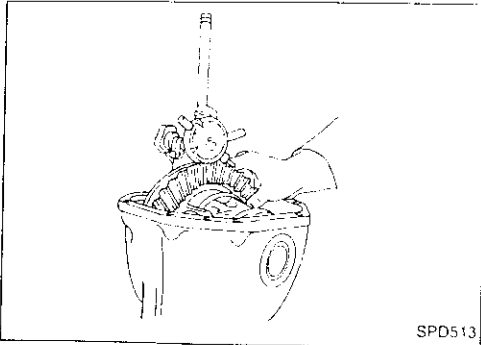

SPD513

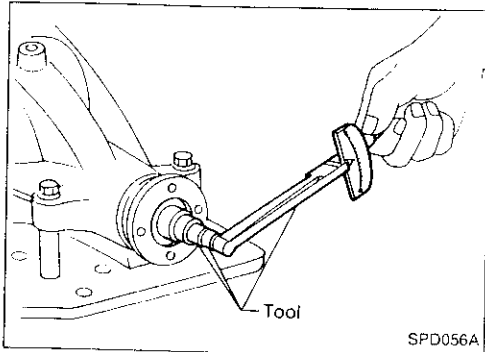

SPD056A

15. Measure ring gear to drive pinion backlash with a dial indicator.

**Ring gear to drive pinion backlash:**

**0.10 - 0.15 mm (0.0039 - 0.0059 in)**

- If backlash is too small, adjustment of shim thickness is required. Decrease thickness of left shim and increase thickness of right shim by the same amount.

If backlash is too great, reverse the above procedure.

**Never change the total amount of shims as it will change the bearing preload.**

16. Check total preload with Tool.

**When checking preload, turn drive pinion in both directions several times to seat bearing rollers correctly.**

**Total preload:**

**1.4 - 3.1 N·m (14 - 32 kg-cm, 12 - 28 in-lb)**

- If preload is too great, remove the same amount of shim from each side.
- If preload is too small, add the same amount of shim to each side.

**Never add or remove a different number of shims for each side. Difference in number of shims will change ring gear to drive pinion backlash.**

17. Recheck ring gear to drive pinion backlash. Increase or decrease in thickness of shims will cause change to ring gear to pinion backlash.

- Check whether the backlash varies excessively in different places. Foreign matter may be caught between the ring gear and the differential case causing the trouble.
- The backlash can vary greatly even when the ring gear runout is within a specified range. In that case, replace the hypoid gear set or differential case.

18. Check tooth contact.

Refer to ADJUSTMENT (PD-23).

19. Apply multi-purpose grease to cavity at sealing lips of oil seal. Install side oil seal.

**Tool number: KV38100200**

20. Install rear cover and gasket.

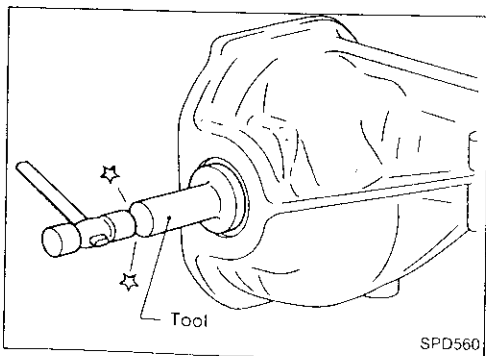

SPD560

## DIFFERENTIAL OIL COOLER SYSTEM

### Description

- The differential oil pumps automatically repeat ON-OFF operation according to the differential gear oil temperature.

OFF → ON 130°C (266°F)

ON → OFF 120°C (248°F)

However, the pumps will not operate when the vehicle speed is less than 120 km/h (75 MPH).

- When the oil temperature becomes excessively high, the warning lamp in the combination meter will illuminate.

#### Differential gear oil:

OFF → ON 180°C (356°F)

ON → OFF 150°C (302°F)

### Removal and Installation

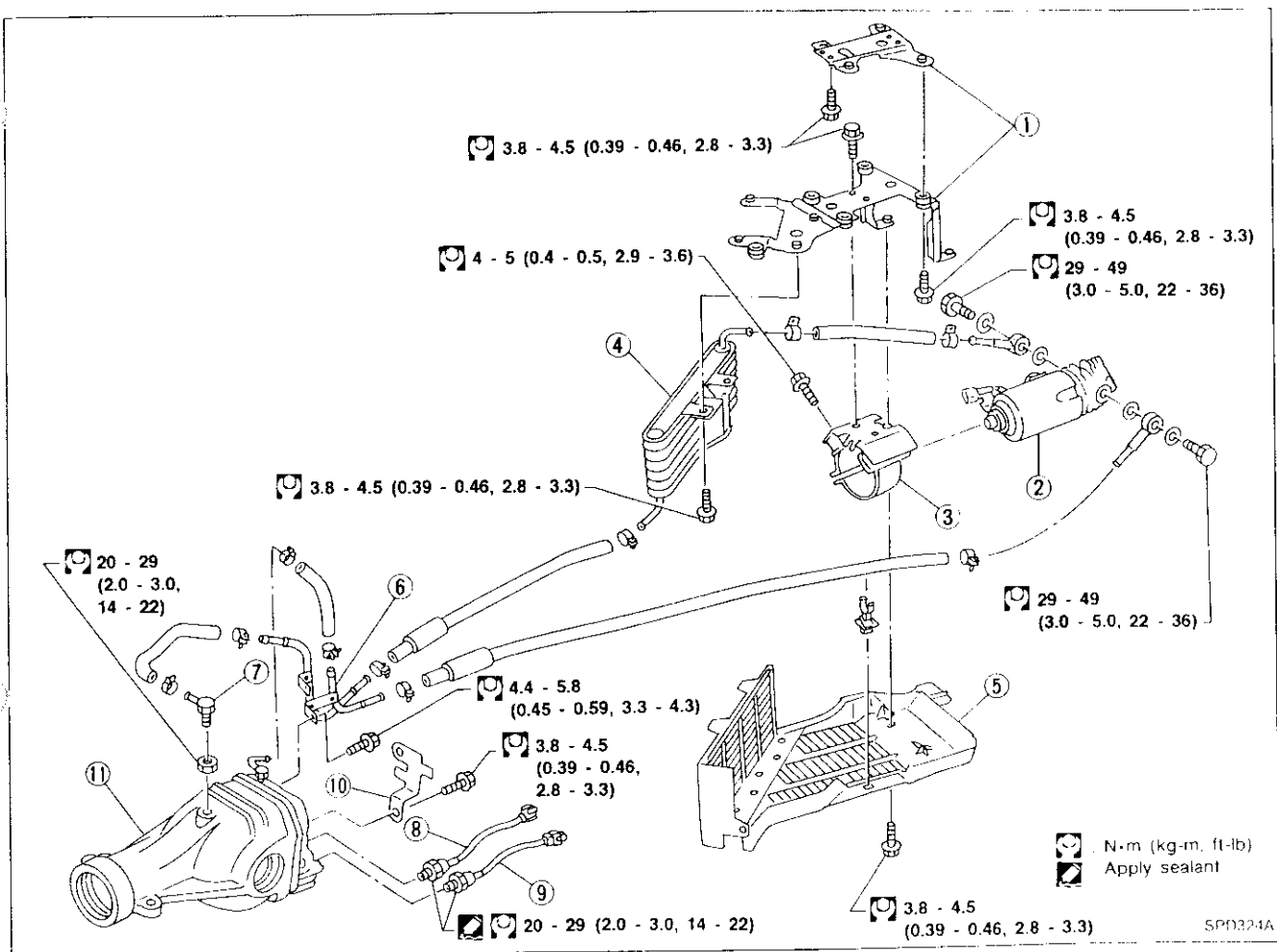

- |                             |                            |                          |
|-----------------------------|----------------------------|--------------------------|
| ① Oil pump mounting bracket | ⑤ Oil cooler protector     | ⑨ Oil temperature switch |
| ② Oil pump assembly         | ⑥ Oil cooler tube assembly | ⑩ Connector bracket      |
| ③ Oil pump bracket          | ⑦ Inlet connector          | ⑪ Final drive            |
| ④ Oil cooler assembly       | ⑧ Warning lamp switch      |                          |

# DIFFERENTIAL OIL COOLER SYSTEM

## Wiring Diagram

PD-DIFF-01

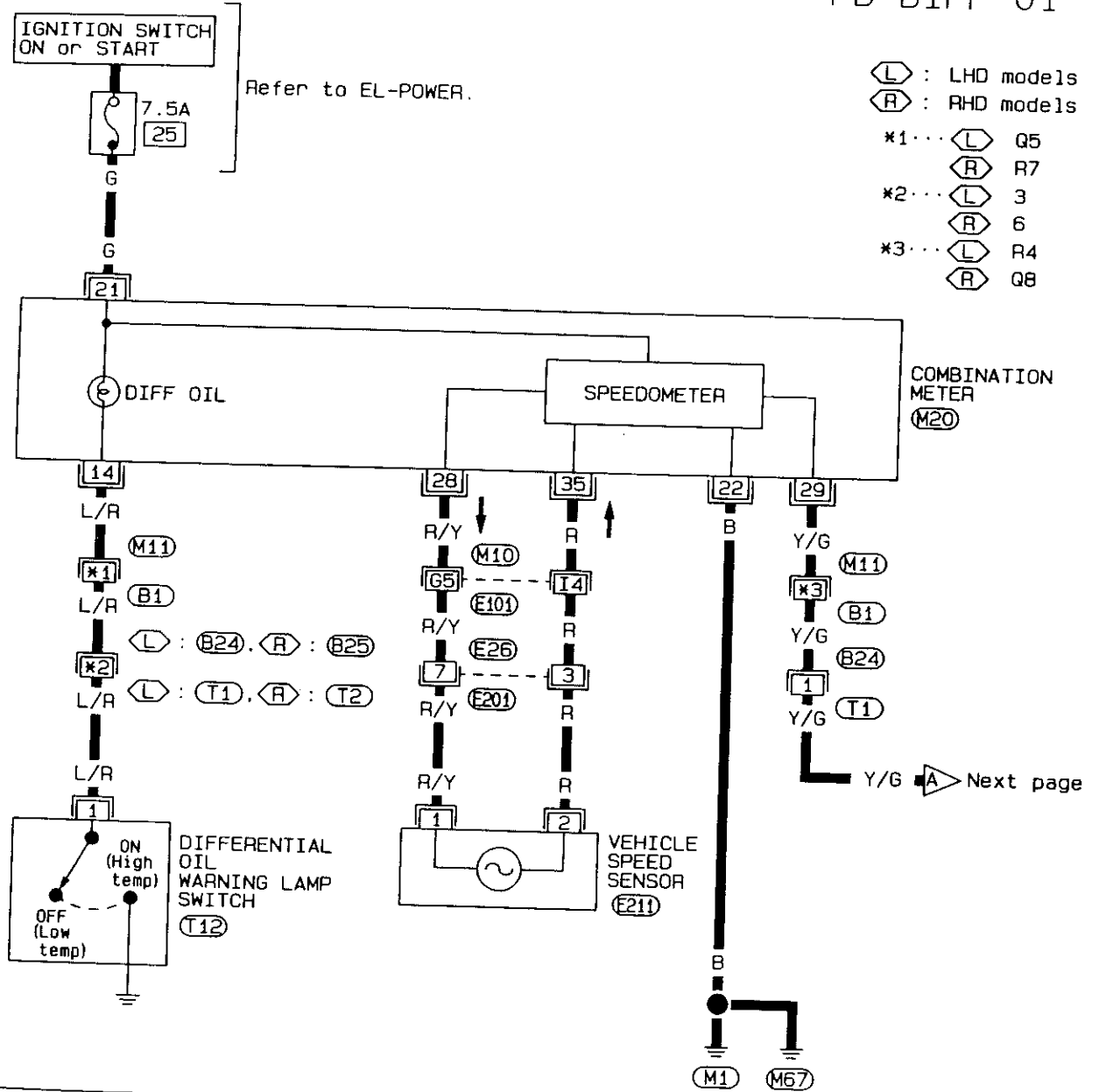

- ⬅ L : LHD models
- ⬅ R : RHD models
- \*1... ⬅ L Q5
- ⬅ R R7
- \*2... ⬅ L 3
- ⬅ R 6
- \*3... ⬅ L R4
- ⬅ R Q8

COMBINATION METER (M20)

Y/G → A Next page

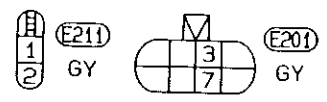
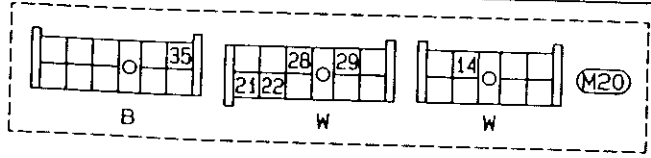

Refer to last page (Foldout page).  
 (M10), (E101)  
 (M11), (R1)

# DIFFERENTIAL OIL COOLER SYSTEM

## Wiring Diagram (Cont'd)

PD-DIFF-02

- Ⓛ : LHD models
- Ⓡ : RHD models
- \*4... Ⓛ 29
- Ⓡ 28
- \*5... Ⓛ M1
- Ⓡ Q7
- \*6... Ⓛ 6
- Ⓡ 2

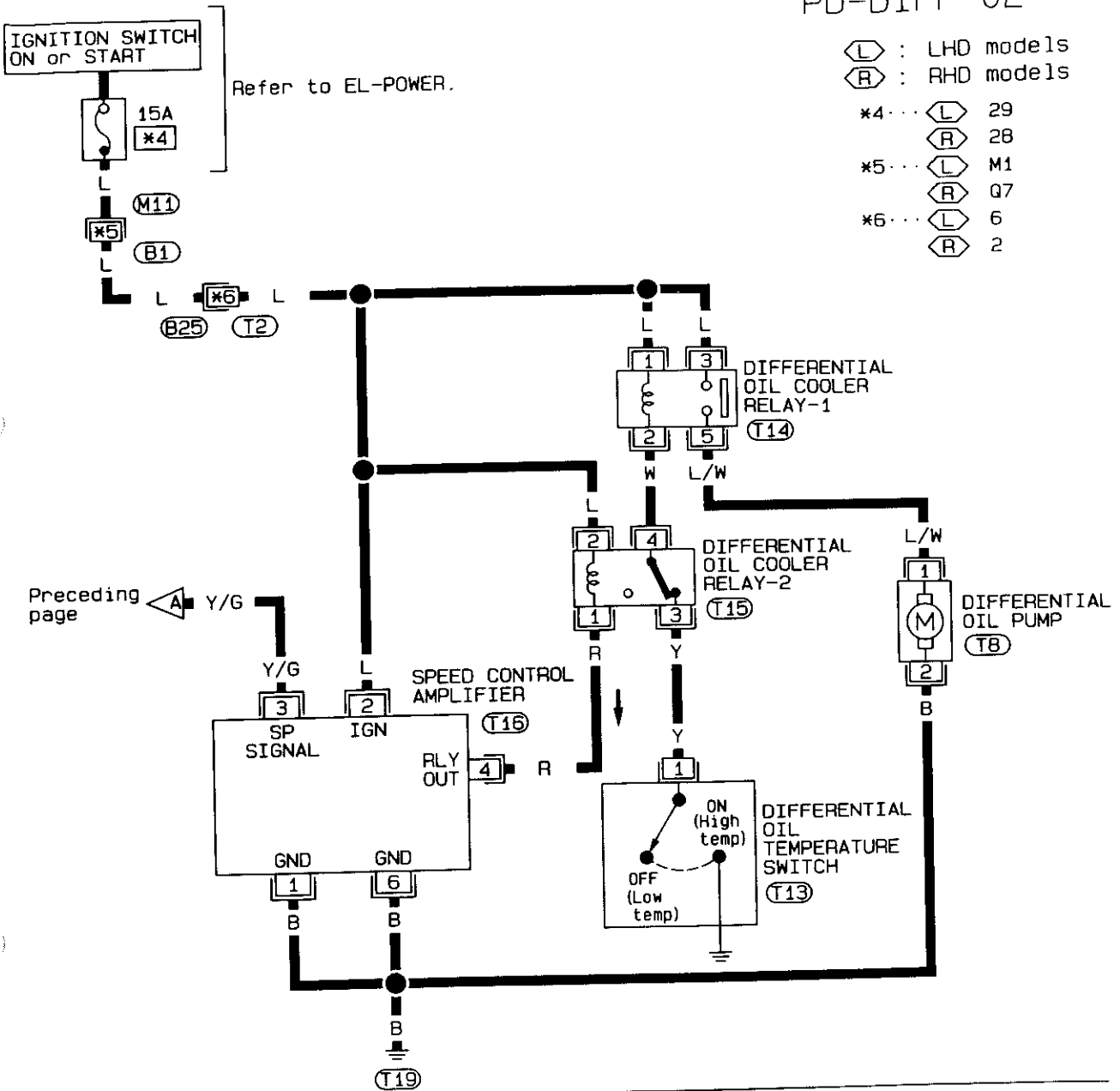

Preceding page

PD

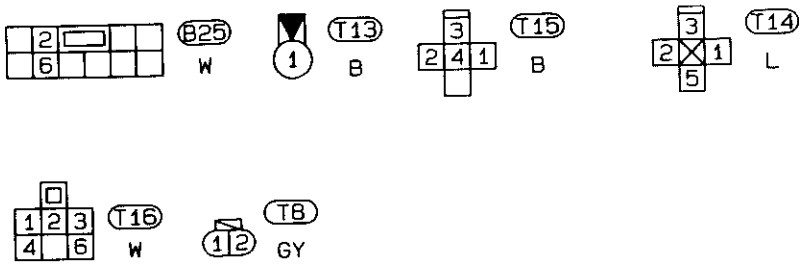

Refer to last page (Foldout page).  
 (M11), (B1)

SPD327A

## DIFFERENTIAL OIL COOLER SYSTEM

### Inspection

Thoroughly clean all parts in cleaning solvent and blow dry with compressed air, if available.

### OIL PUMP ASSEMBLY

Replace oil pump assembly when motor does not rotate because of motor seizure or other damage.

### OIL COOLER ASSEMBLY, OIL TUBE ASSEMBLY, OIL HOSE

If oil leakage is detected during removal, replace oil cooler assembly or oil tube.

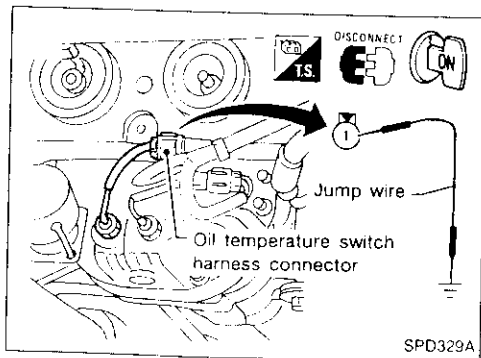

### Trouble Diagnoses

#### SYMPTOM:

Oil pump does not rotate.

#### CHECK OIL PUMP OPERATION

1. Disconnect speed control amplifier harness connector.
2. Disconnect oil pump temperature switch harness connector.
3. Turn ignition switch "ON".
4. Connect jump wire between oil temperature switch harness connector terminal ① and ground.

#### Oil pump rotates:

Refer to Procedure A.

Oil pump does not rotate:

Refer to Procedure B.

# DIFFERENTIAL OIL COOLER SYSTEM

## Trouble Diagnoses (Cont'd)

### Procedure A

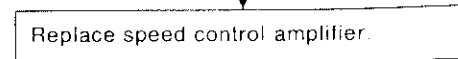
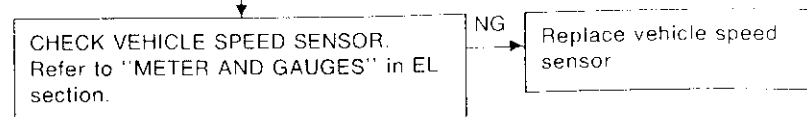
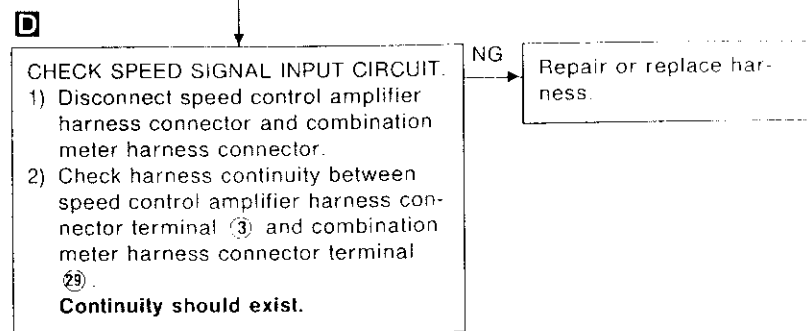
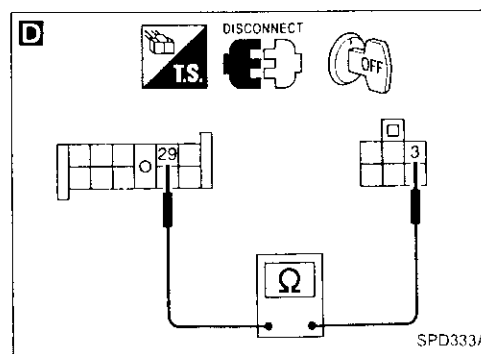
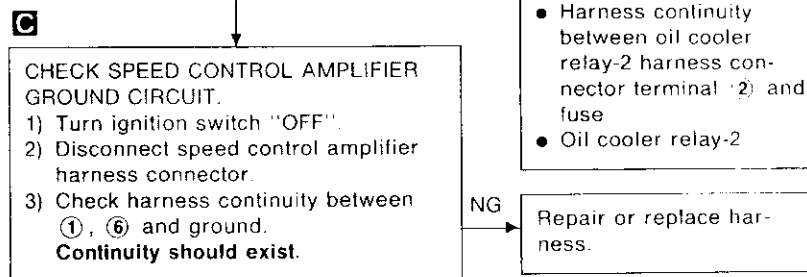
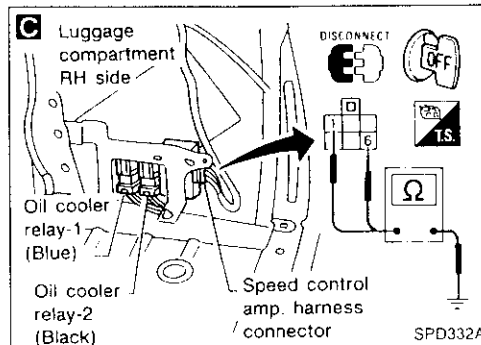
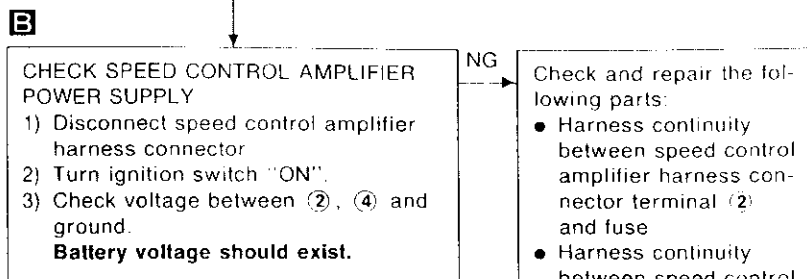
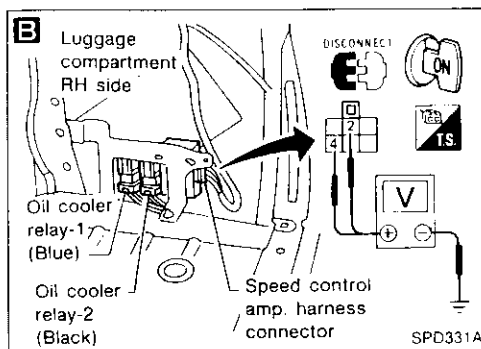
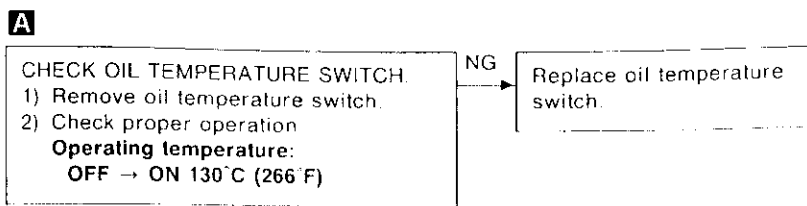
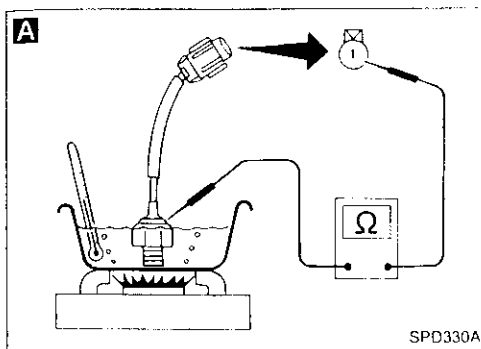

PD



# DIFFERENTIAL OIL COOLER SYSTEM

## Trouble Diagnoses (Cont'd)

### Procedure B

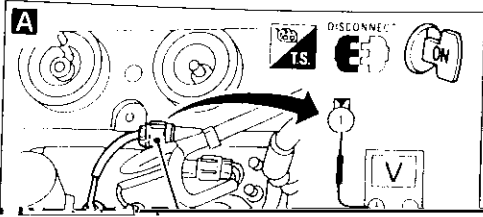

**A**

CHECK POWER SUPPLY.

- 1) Disconnect oil temperature switch

NG →

Check and repair the following parts:

## SERVICE DATA AND SPECIFICATIONS (SDS)

### Propeller Shaft

#### GENERAL SPECIFICATIONS

Unit: mm (in)		
Applied model	M/T	A/T
Propeller shaft model	3S71A	
Number of joints	3	
Coupling method with transmission	Sleeve type	
Type of journal bearings	Shell type (Non-disassembly type)	
Distance between yokes	63.0 (2.480)	
Shaft length (Spider to spider)		
1st	421.0 (16.57)	441.0 (17.36)
2nd		
Without ABS	650.0 (25.59)	
With ABS	636.0 (25.04)	
Shaft outer diameter		
1st	75.0 (2.953)	
2nd	75.0 (2.953)	50.8 (2.000)

#### SPECIFICATIONS AND ADJUSTMENT

Unit: mm (in)	
Propeller shaft model	3S71A
Propeller shaft runout limit	0.6 (0.024)
Journal axial play	0 (0)

### Final Drive

#### GENERAL SPECIFICATIONS

Unit: mm (in)		
Applied model	M/T	A/T
Final drive model	R200V	
Ring gear pitch diameter mm (in)	205 (8.07)	
Gear ratio	3.692	3.916
Number of teeth (Ring gear/drive pinion)	48/13	47/12
Oil capacity l (Imp pt)	1.2 - 1.4 (2-1/8 - 2-1/2)	
Number of pinion gears	4	
Side gear bearing spacer location	Right	

#### INSPECTION AND ADJUSTMENT

##### Ring gear runout

Ring gear runout limit mm (in)	0.05 (0.0020)
-----------------------------------	---------------

##### Side gear adjustment

Clearance between side gear and differential case mm (in)	0.03 - 0.09 (0.0012 - 0.0035)
--	----------------------------------

#### Available side gear thrust washers

Thickness	mm (in)	Part number
0.80	(0.0315)	38424-40F60
0.83	(0.0327)	38424-40F61
0.86	(0.0339)	38424-40F62
0.89	(0.0350)	38424-40F63
0.92	(0.0362)	38424-40F64
0.95	(0.0374)	38424-40F65
0.98	(0.0386)	38424-40F66
1.01	(0.0398)	38424-40F67
1.04	(0.0409)	38424-40F68
1.07	(0.0421)	38424-40F69
1.10	(0.0433)	38424-40F70
1.13	(0.0445)	38424-40F71
1.16	(0.0457)	38424-40F72
1.19	(0.0469)	38424-40F73
1.22	(0.0480)	38424-40F74
1.25	(0.0492)	38424-40F75
1.28	(0.0504)	38424-40F76
1.31	(0.0516)	38424-40F77
1.34	(0.0528)	38424-40F78
1.37	(0.0539)	38424-40F79
1.40	(0.0551)	38424-40F80
1.43	(0.0563)	38424-40F81
1.46	(0.0575)	38424-40F82
1.49	(0.0587)	38424-40F83

PD

## SERVICE DATA AND SPECIFICATIONS (SDS)

### Final Drive (Cont'd)

#### Drive pinion height adjustment

##### Available pinion height adjusting washers

Thickness	mm (in)	Part number
3.09	(0.1217)	38154-P6017
3.12	(0.1228)	38154-P6018
3.15	(0.1240)	38154-P6019
3.18	(0.1252)	38154-P6020
3.21	(0.1264)	38154-P6021
3.24	(0.1276)	38154-P6022
3.27	(0.1287)	38154-P6023
3.30	(0.1299)	38154-P6024
3.33	(0.1311)	38154-P6025
3.36	(0.1323)	38154-P6026
3.39	(0.1335)	38154-P6027
3.42	(0.1346)	38154-P6028
3.45	(0.1358)	38154-P6029
3.48	(0.1370)	38154-P6030
3.51	(0.1382)	38154-P6031
3.54	(0.1394)	38154-P6032
3.57	(0.1406)	38154-P6033
3.60	(0.1417)	38154-P6034
3.63	(0.1429)	38154-P6035
3.66	(0.1441)	38154-P6036

#### Drive pinion preload adjustment

Drive pinion bearing adjusting method	Pinion bearing adjusting washer and spacer
Drive pinion preload with front oil seal	N-m (kg-cm, in-lb) 1.1 - 1.4 (11 - 14, 9.5 - 12.2)

##### Available drive pinion bearing preload adjusting washers

Thickness	mm (in)	Part number
3.80 - 3.82	(0.1496 - 0.1504)	38125-61001
3.82 - 3.84	(0.1504 - 0.1512)	38126-61001
3.84 - 3.86	(0.1512 - 0.1520)	38127-61001
3.86 - 3.88	(0.1520 - 0.1528)	38128-61001
3.88 - 3.90	(0.1528 - 0.1535)	38129-61001
3.90 - 3.92	(0.1535 - 0.1543)	38130-61001
3.92 - 3.94	(0.1543 - 0.1551)	38131-61001
3.94 - 3.96	(0.1551 - 0.1559)	38132-61001
3.96 - 3.98	(0.1559 - 0.1567)	38133-61001
3.98 - 4.00	(0.1567 - 0.1575)	38134-61001
4.00 - 4.02	(0.1575 - 0.1583)	38135-61001
4.02 - 4.04	(0.1583 - 0.1591)	38136-61001
4.04 - 4.06	(0.1591 - 0.1598)	38137-61001
4.06 - 4.08	(0.1598 - 0.1606)	38138-61001
4.08 - 4.10	(0.1606 - 0.1614)	38139-61001

##### Available drive pinion bearing preload adjusting spacers

Length	mm (in)	Part number
54.50	(2.1457)	38165-B4000
54.80	(2.1575)	38165-B4001
55.10	(2.1693)	38165-B4002
55.40	(2.1811)	38165-B4003
55.70	(2.1929)	38165-B4004
56.00	(2.2047)	38165-61001

#### Total preload adjustment

Drive pinion to ring gear backlash	mm (in)	0.10 - 0.15 (0.0039 - 0.0059)
Total preload	N-m (kg-cm, in-lb)	1.4 - 3.1 (14 - 32, 12 - 28)
Side bearing adjusting method		Adjusting washer

##### Available side bearing adjusting washers

Thickness	mm (in)	Part number
2.00	(0.0787)	38453-N3100
2.05	(0.0807)	38453-N3101
2.10	(0.0827)	38453-N3102
2.15	(0.0846)	38453-N3103
2.20	(0.0866)	38453-N3104
2.25	(0.0886)	38453-N3105
2.30	(0.0906)	38453-N3106
2.35	(0.0925)	38453-N3107
2.40	(0.0945)	38453-N3108
2.45	(0.0965)	38453-N3109
2.50	(0.0984)	38453-N3110
2.55	(0.1004)	38453-N3111
2.60	(0.1024)	38453-N3112
2.65	(0.1043)	38453-N3113

# FRONT AXLE & FRONT SUSPENSION

## SECTION **FA**

### CONTENTS

<b>PRECAUTIONS AND PREPARATION</b> .....	2	Wheel Hub and Knuckle .....	8
Precautions.....	2	ABS Sensor Rotor.....	10
Special Service Tools .....	2	Baffle Plate.....	10
Commercial Service Tools .....	3	<b>FRONT SUSPENSION</b> .....	11
<b>FRONT SUSPENSION SYSTEM</b> .....	4	Coil Spring and Strut Assembly.....	12
<b>ON-VEHICLE SERVICE</b> .....	5	Tension Rod and Stabilizer Bar.....	13
Front Axle and Front Suspension Parts.....	5	Transverse Link and Lower Ball Joint.....	14
Front Wheel Bearing.....	5	<b>SERVICE DATA AND SPECIFICATIONS (SDS)</b> .....	15
Front Wheel Alignment.....	5	General Specifications.....	15
<b>FRONT AXLE</b> .....	8	Inspection and Adjustment.....	15

FA

## PRECAUTIONS AND PREPARATION

### Commercial Service Tools

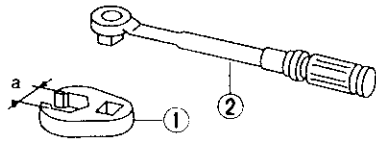
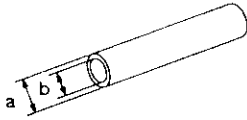
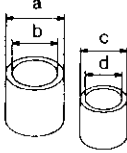
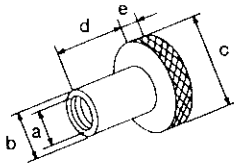
Tool name	Description
Equivalent to GG94310000 ① Flare nut crows foot ② Torque wrench	 <p style="text-align: right;">Removing and installing each brake piping</p> <p>NT360</p> <p style="text-align: right;">a: 10 mm (0.39 in)</p>
Baffle plate drift	 <p style="text-align: right;">Installing baffle plate</p> <p>NT065</p> <p style="text-align: right;">a: 88 mm (3.46 in) dia. b: 68 mm (2.68 in) dia.</p>
Tension rod bushing drift	 <p style="text-align: right;">Removing and installing tension rod bushing</p> <p>NT155</p> <p style="text-align: right;">a: 75 mm (2.95 in) dia. b: 66 mm (2.60 in) dia. c: 62 mm (2.44 in) dia. d: 25 - 55 mm (0.98 - 2.17 in) dia.</p>
Attachment Wheel alignment	 <p style="text-align: right;">Measure wheel alignment</p> <p>NT148</p> <p style="text-align: right;">a: Screw M22 x 1.5 b: 35 (1.38) dia. c: 65 (2.56) dia. d: 56 (2.20) e: 12 (0.47) Unit: mm (in)</p>

FA

## PRECAUTIONS AND PREPARATION

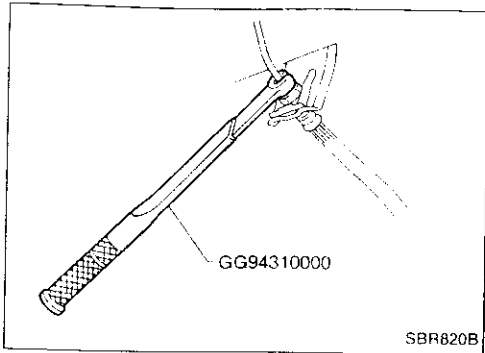

### Precautions

- When installing rubber parts, final tightening must be carried out under unladen condition\* with tires on ground.
- \*: Fuel, radiator coolant and engine oil full. Spare tire, jack, hand tools and mats in designated positions.
- After installing removed suspension parts, check wheel alignment and adjust if necessary.
- Use flare nut wrench when removing or installing brake tubes.
- Always torque brake lines when installing.

### Special Service Tools

Tool number Tool name	Description
HT72520000 Ball joint remover	<p>NT146</p> <p>Removing tie-rod outer end and lower ball joint</p>
HT71780000 Spring compressor	<p>NT144</p> <p>Removing and installing coil spring</p>
ST35652000 Strut attachment	<p>NT145</p> <p>Fixing strut assembly</p>
GG94310000 Flare nut torque wrench	<p>NT406</p> <p>Removing and installing brake piping</p> <p>a: 10 mm (0.39 in)</p>

# FRONT SUSPENSION SYSTEM

SEC. 401

When installing rubber parts, final tightening must be carried out under unladen condition\* with tires on ground.  
 \* Fuel, radiator coolant and engine oil full.  
 Spare tire, jack, hand tools and mats in designated positions.

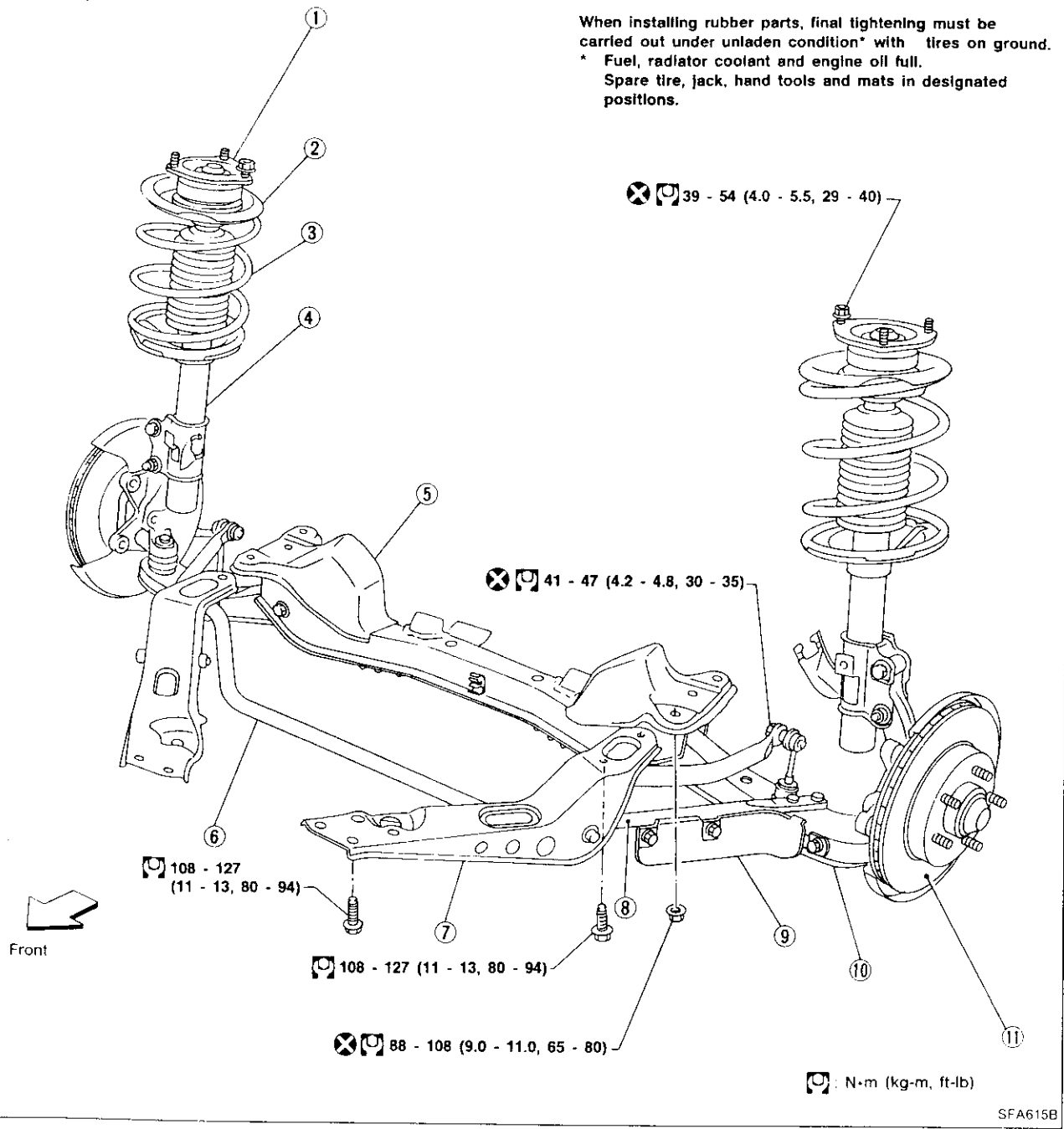

SFA615B

- |                            |                           |                                   |
|----------------------------|---------------------------|-----------------------------------|
| ① Strut mounting insulator | ⑤ Front suspension member | ⑨ Air guide                       |
| ② Spring upper seat        | ⑥ Front stabilizer        | ⑩ Transverse link with ball joint |
| ③ Coil spring              | ⑦ Tension rod bracket     | ⑪ Brake rotor                     |
| ④ Strut assembly           | ⑧ Tension rod             |                                   |

## ON-VEHICLE SERVICE

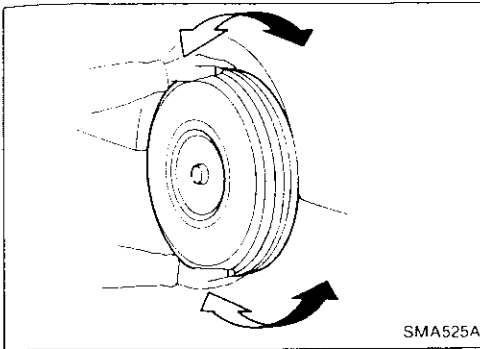

### Front Axle and Front Suspension Parts

Check front axle and front suspension parts for looseness, cracks, wear or other damage.

- Shake each front wheel to check for excessive play.
- Retighten all axle and suspensions nuts and bolts to the specified torque.

#### Tightening torque:

Refer to **FRONT SUSPENSION (FA-11)**.

- Make sure that cotter pins are inserted.

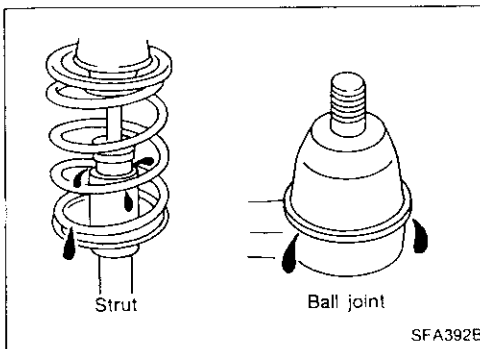

- Check strut (shock absorber) for oil leakage or other damage.
- Check suspension ball joint for grease leakage and ball joint dust cover for cracks or other damage. If ball joint dust cover is cracked or damaged, replace transverse link.

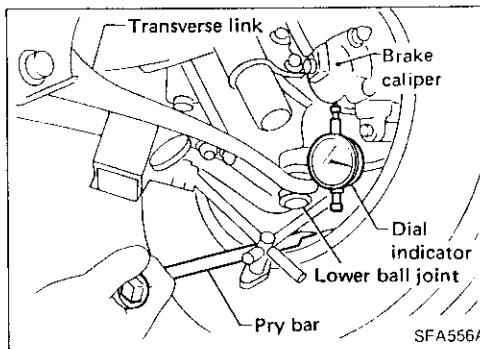

- Check suspension ball joint end play.
  - (1) Jack up front of vehicle and set the stands.
  - (2) Clamp dial indicator onto transverse link and place indicator tip on lower edge of brake caliper.
  - (3) Make sure front wheels are straight and brake pedal is depressed.
  - (4) Place a pry bar between transverse link and inner rim of road wheel.
  - (5) While raising and releasing pry bar, observe maximum dial indicator value.

#### Vertical end play:

**0 mm (0 in)**

- (6) If ball joint movement is beyond specifications, remove and recheck it.

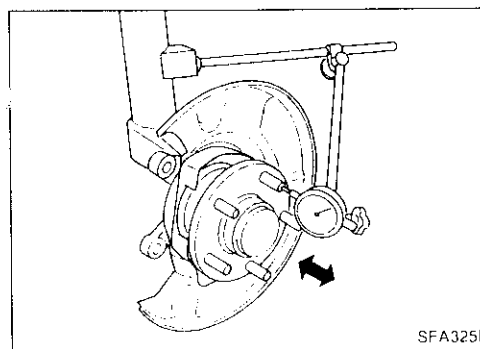

### Front Wheel Bearing

- Check that wheel bearings operate smoothly.
- Check axial end play.

#### Axial end play:

**0.05 mm (0.0020 in) or less**

- If out of specification or wheel bearing does not turn smoothly, replace wheel bearing assembly. Refer to **FRONT AXLE — Wheel Hub and Knuckle (FA-8)**.

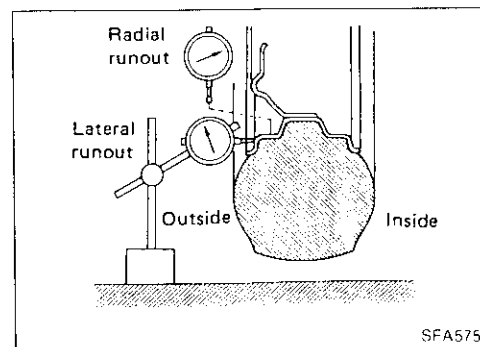

### Front Wheel Alignment

Before checking front wheel alignment, be sure to make a preliminary inspection (Unladen\*).

- \*: Fuel, radiator coolant and engine oil full. Spare tire, jack, hand tools and mats in designated positions.

FA



## ON-VEHICLE SERVICE

### Front Wheel Alignment (Cont'd)

#### PRELIMINARY INSPECTION

1. Check tires for wear and improper inflation.
2. Check wheel runout.

#### Wheel runout:

Refer to SDS (FA-15).

3. Check front wheel bearings for looseness.
4. Check front suspension for looseness.
5. Check steering linkage for looseness.
6. Check that front shock absorbers work properly.
7. Check vehicle posture (Unladen).

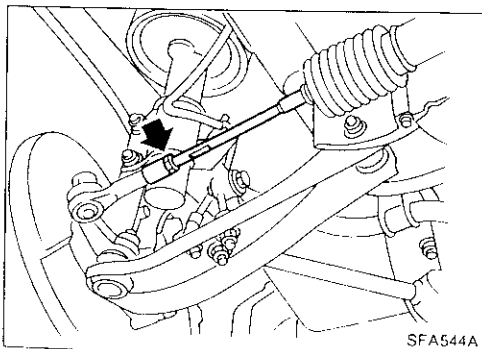
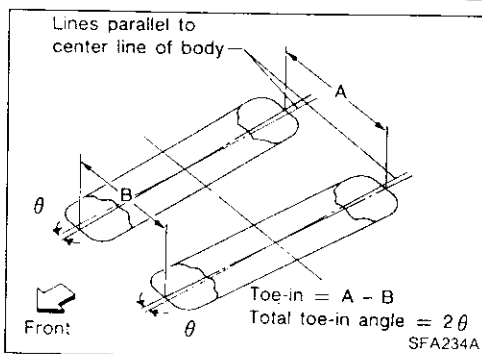
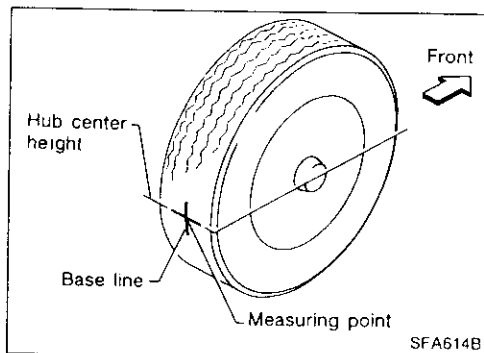
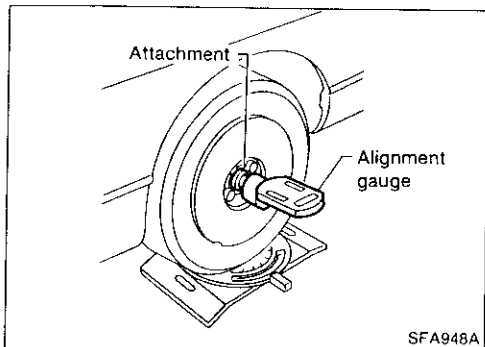

#### CAMBER, CASTER AND KINGPIN INCLINATION

Camber, caster and kingpin inclination are preset at factory and cannot be adjusted.

1. Measure camber, caster and kingpin inclination of both right and left wheels with a suitable alignment gauge.

#### Camber, Caster and Kingpin inclination:

Refer to SDS (FA-15).

2. If camber, caster or kingpin inclination is not within specification, inspect front suspension parts. Replace damaged or worn out parts.

#### TOE-IN

Measure toe-in using following procedure. If out of specification, inspect and replace any damaged or worn front suspension parts.

#### WARNING:

- Perform following procedure always on a flat surface.
  - Make sure that no person is in front of the vehicle before pushing it.
1. Move rear of vehicle up and down to stabilize the posture.
  2. Push the vehicle straight ahead about 5 m (196.9 in).
  3. Put a mark on base line of the tread (rear side) at the same height of hub center to be a measuring point.
  4. Measure distance "A" (rear side).
  5. Push the vehicle slowly ahead to turn the wheels around 180 degrees.

If the wheels have passed 180 degrees, try the above procedure again from the beginning. Never push vehicle backward.

6. Measure distance "B" (front side).

#### Toe-in (A - B):

Refer to SDS (FA-15).

7. Adjust toe-in by varying length of steering tie-rods.
  - a. Loosen lock nuts.
  - b. Adjust toe-in by turning forward and reverse tie-rod.

## ON-VEHICLE SERVICE

### Front Wheel Alignment (Cont'd)

Make sure both tie-rods are the same length.

**Standard length "L":**

**Refer to SDS in ST section.**

- c. Tighten lock nuts to specified torque.

**Lock nut tightening torque:**

**Refer to ST section.**

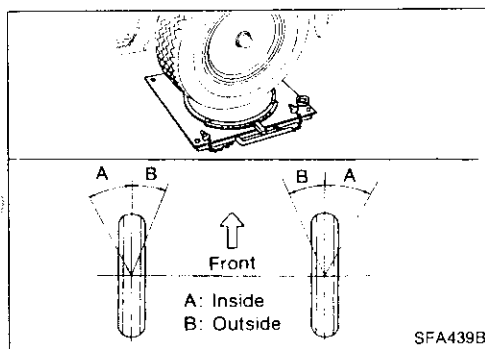
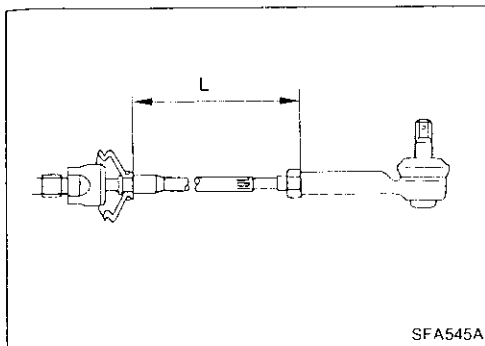

### FRONT WHEEL TURNING ANGLE

Turning angle is set by stroke length of steering gear rack and cannot be adjusted.

1. Set wheels in straight-ahead position. Then move vehicle forward until front wheels rest on turning radius gauge properly.
2. Rotate steering wheel all the way right and left; measure turning angle.

**Do not hold the steering wheel on full lock for more than 15 seconds.**

**Wheel turning angle (Full turn):**

**Refer to SDS (FA-15).**

FA

## FRONT AXLE

### Wheel Hub and Knuckle

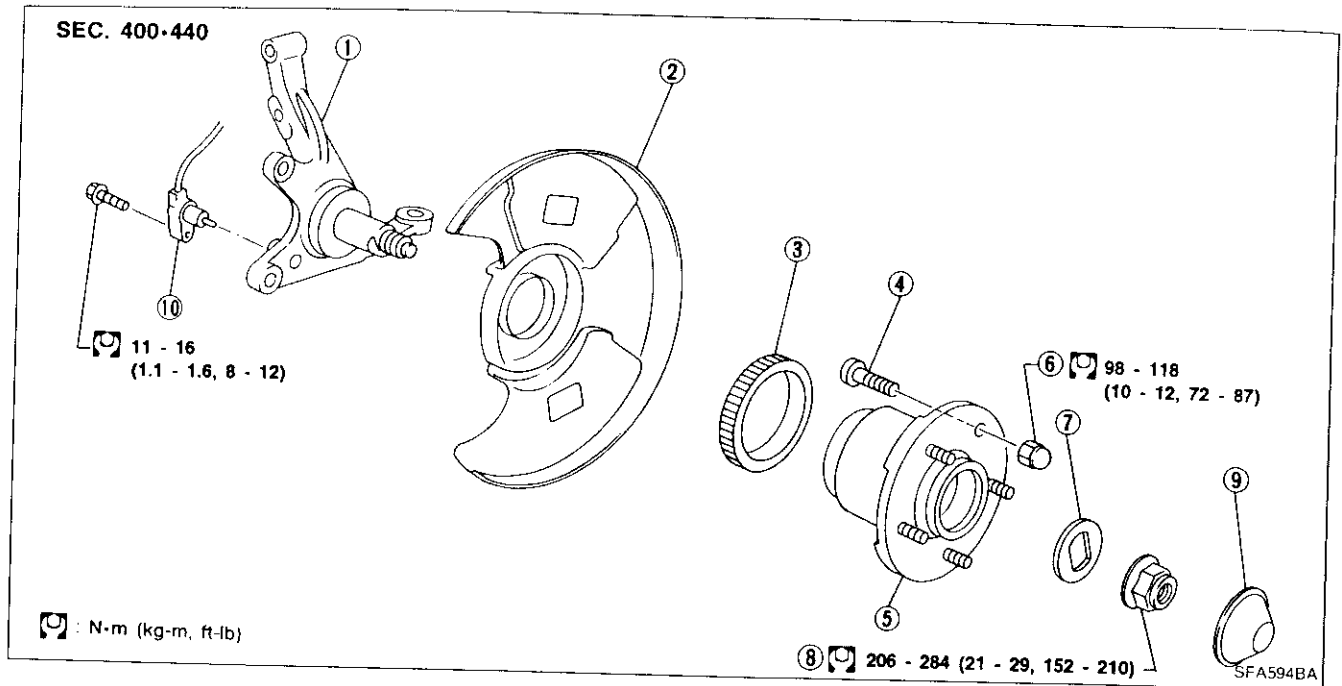

- ① Knuckle spindle
- ② Baffle plate
- ③ ABS ring
- ④ Hub bolt

- ⑤ Wheel hub bearing
- ⑥ Wheel nut
- ⑦ Lock washer

- ⑧ Wheel bearing lock nut
- ⑨ Hub cap
- ⑩ ABS sensor

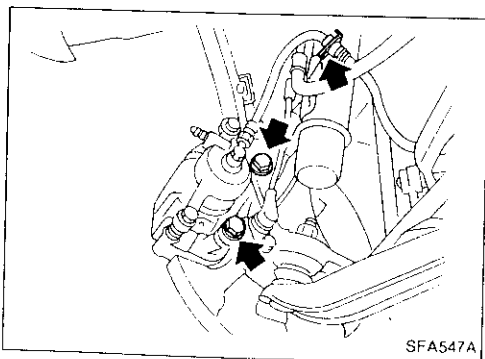

### REMOVAL

#### CAUTION:

Wheel hub bearing usually does not require maintenance. If any of the following symptoms are noted, replace wheel hub bearing assembly.

- Growling noise is emitted from wheel hub bearing during operation.
- Wheel hub bearing drags or turns roughly. This occurs when turning hub by hand after bearing lock nut is tightened to specified torque.
- If the wheel hub bearing assembly is removed, it must be renewed. The old assembly must not be re-used.

Remove brake caliper assembly and rotor.

Before removing the front axle assembly, disconnect the ABS wheel sensor from the assembly. Then move it away from the front axle assembly area.

Failure to do so may result in sensor wires being damaged and the sensor becoming inoperative.

Suspend caliper assembly with wire so as not to stretch brake hose.

Be careful not to depress brake pedal, or piston will pop out.

## FRONT AXLE

### Wheel Hub and Knuckle (Cont'd)

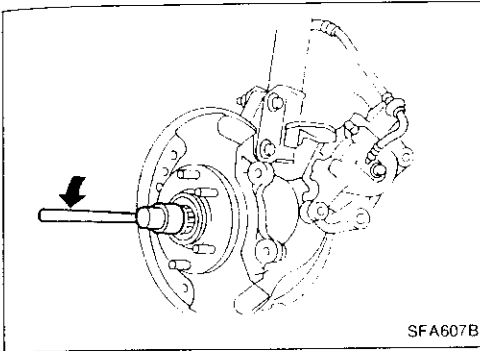

- Remove wheel bearing lock nut. Remove wheel hub from spindle.

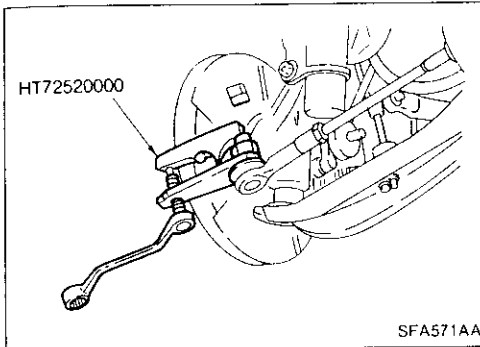

- Remove tie-rod ball joint and lower ball joint.

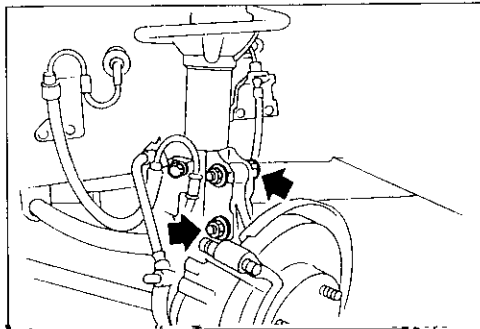

- Disconnect knuckle from strut.

11  
12  
13  
14  
15  
16  
17  
18  
19  
20  
21  
22  
23  
24  
25  
26  
27  
28  
29  
30  
31  
32  
33  
34  
35  
36  
37  
38  
39  
40  
41  
42  
43  
44  
45  
46  
47  
48  
49  
50  
51  
52  
53  
54  
55  
56  
57  
58  
59  
60  
61  
62  
63  
64  
65  
66  
67  
68  
69  
70  
71  
72  
73  
74  
75  
76  
77  
78  
79  
80  
81  
82  
83  
84  
85  
86  
87  
88  
89  
90  
91  
92  
93  
94  
95  
96  
97  
98  
99  
100

FA

### Wheel Hub and Knuckle (Cont'd)

- Check wheel bearing axial end play.  
Axial end play: 0.05 mm (0.0020 in) or less

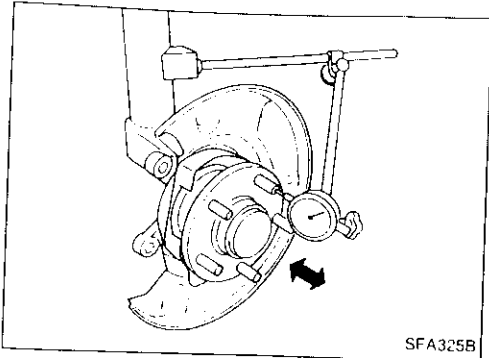

SFA325B

### ABS Sensor Rotor

#### REMOVAL

Remove ABS sensor rotor (models equipped with ABS) or labyrinth plate (models without ABS) with suitable tool.

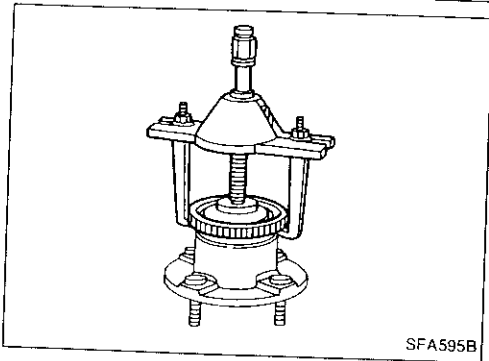

SFA595B

#### INSTALLATION

Press-fit ABS sensor rotor or labyrinth plate.

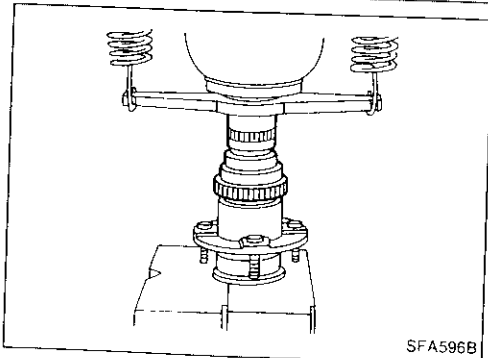

SFA596B

### Baffle Plate

#### REMOVAL

- Mark matchmarks on baffle plate before removing.
  - If baffle plate replacement requires removal of knuckle spindle, separate it equally using a screwdriver.
- Be careful not to scratch knuckle spindle.**

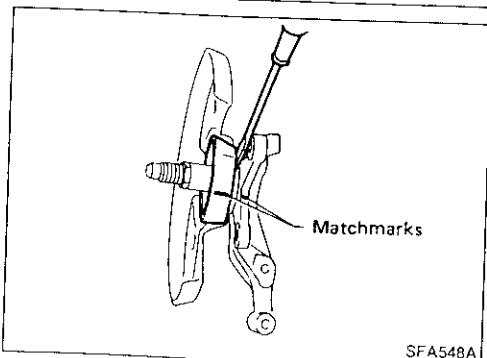

SFA548A

#### INSTALLATION

With matchmarks aligned, install baffle plate by tapping it with a copper hammer and a suitable tool.

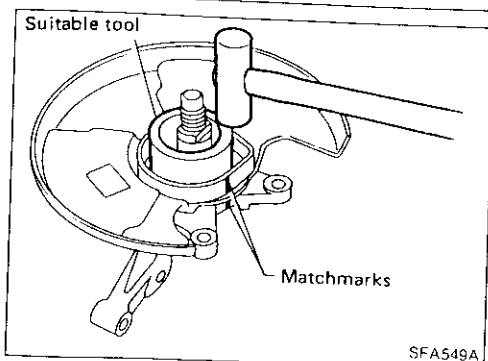

SFA549A

# FRONT SUSPENSION

## SEC. 401

When installing rubber parts, final tightening must be carried out under unladen condition\* with tires on ground.

\* Fuel, radiator coolant and engine oil full. Spare tire, jack, hand tools and mats in designated positions.

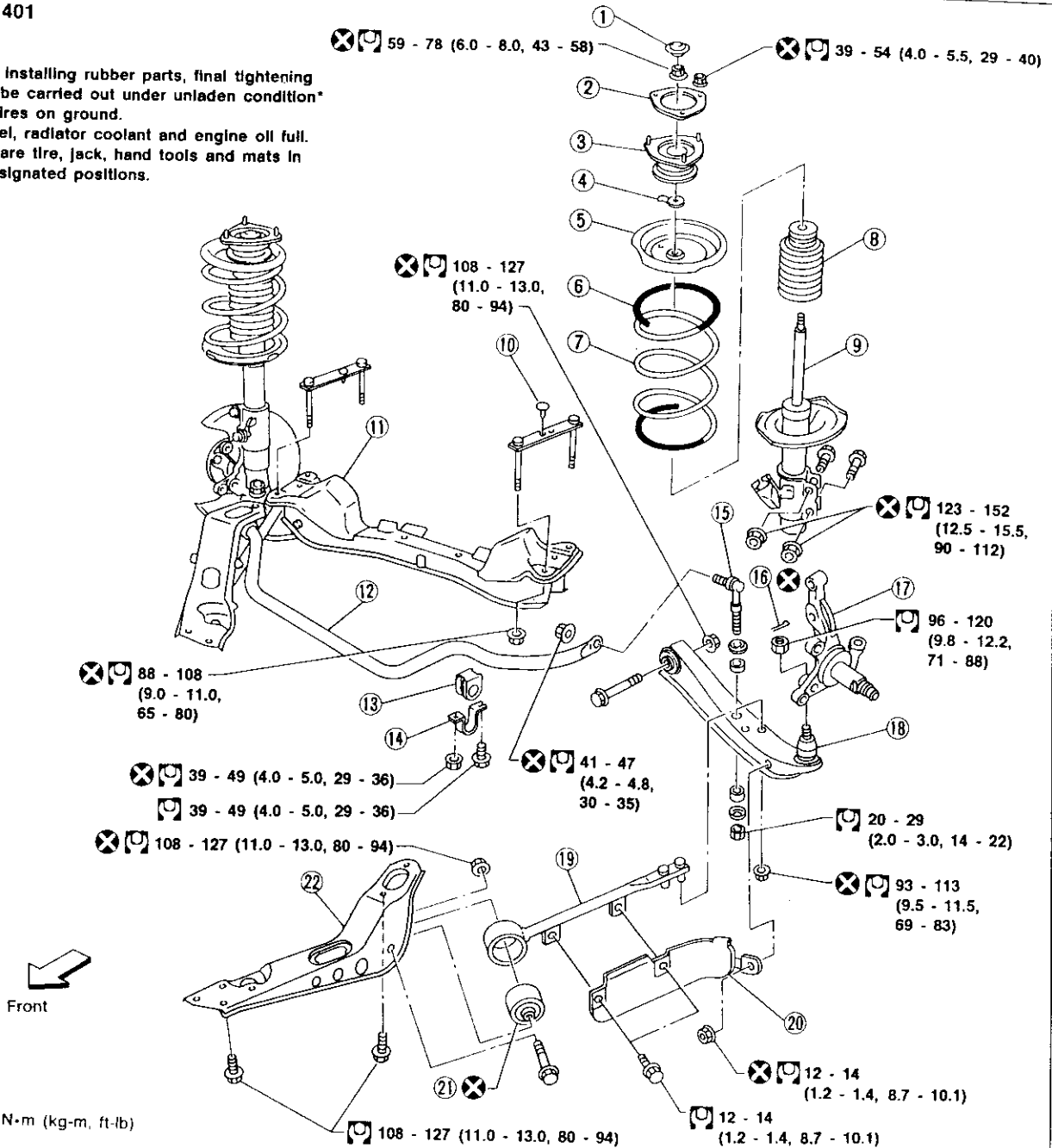

- ① Cap
- ② Gasket
- ③ Strut mounting insulator
- ④ Lock washer
- ⑤ Upper seat
- ⑥ (Polyurethane tube)
- ⑦ Coil spring
- ⑧ Bound bumper

- ⑨ Strut assembly
- ⑩ Plastic clip
- ⑪ Front suspension member
- ⑫ Stabilizer
- ⑬ Bushing
- ⑭ Clamp
- ⑮ Stabilizer connecting rod

- ⑯ Cotter pin
- ⑰ Knuckle spindle
- ⑱ Transverse link with ball joint
- ⑲ Tension rod
- ⑳ Air guide
- ㉑ Tension rod bushing
- ㉒ Tension rod bracket

## FRONT SUSPENSION

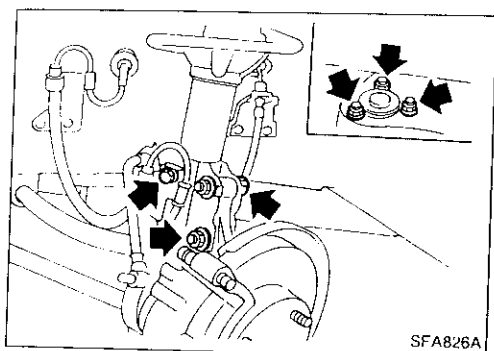

### Coil Spring and Strut Assembly

#### REMOVAL

Remove strut assembly fixing bolts and nuts (to hoodledge).  
**Do not remove piston rod lock nut on vehicle.**

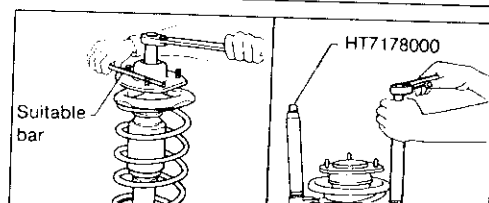

#### DISASSEMBLY

1. Set strut assembly on vise with Tool, then loosen piston rod lock nut.
2. Compress spring with a Tool so that strut mounting insu-

## FRONT SUSPENSION

### Coil Spring and Strut Assembly (Cont'd)

#### ASSEMBLY

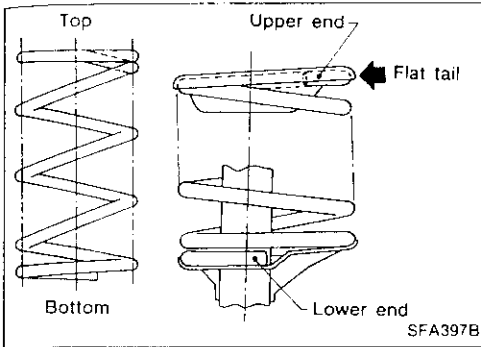

- When installing coil spring, be careful not to reverse top and bottom direction. (Top end is flat.)
- When installing coil spring on strut, it must be positioned as shown in figure at left.

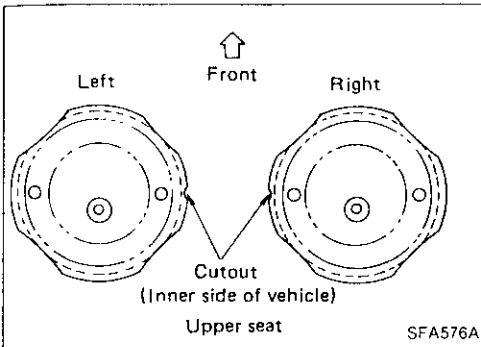

- Install upper spring seat with its cutout facing the inner side of vehicle.

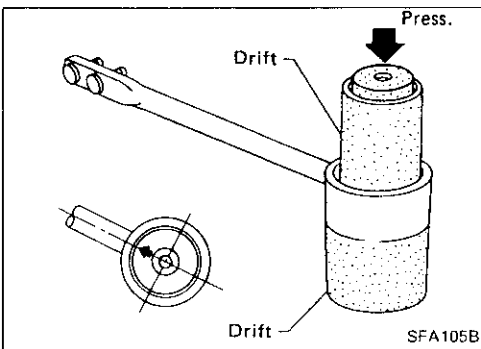

### Tension Rod and Stabilizer Bar

#### REMOVAL AND INSTALLATION

- Remove tension rod and stabilizer bar.
- Place one drift on lower side of tension rod bushing and another on upper side, as shown. Remove tension rod bushing by pressing it out.
- Place arrow mark on bushing facing tension rod before installing bushing.

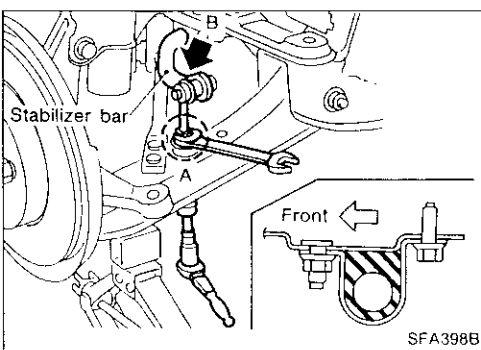

- Install stabilizer rear side bushings, then install front side bushings.
- When installing stabilizer bar clamp, make sure direction is correct (as shown at left).
- When removing and installing stabilizer bar, fix portion A.

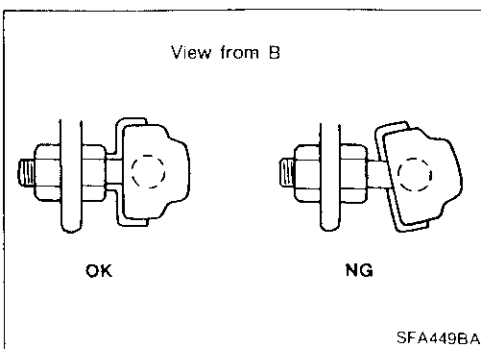

- Install stabilizer bar with ball joint socket properly placed.

FA



## FRONT SUSPENSION

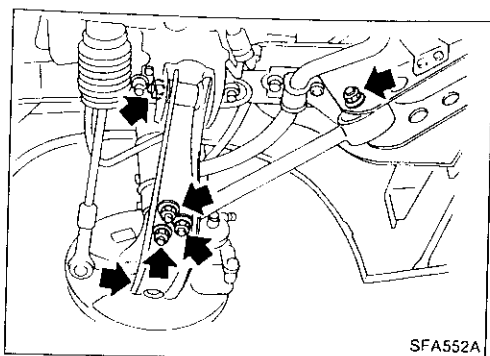

### Transverse Link and Lower Ball Joint

#### REMOVAL AND INSTALLATION

- Remove stabilizer, tension rod, ball joint and transverse link assembly.
- During installation, final tightening must be carried out at curb weight with tires on ground.
- After installation, check wheel alignment. Refer to "Front Wheel Alignment" of ON-VEHICLE SERVICE (FA-5).

#### INSPECTION

##### Transverse link

- Check transverse link for damage, cracks or deformation. Replace it if necessary.
- Check rubber bushing for damage, cracks and deformation. Replace transverse link if necessary.

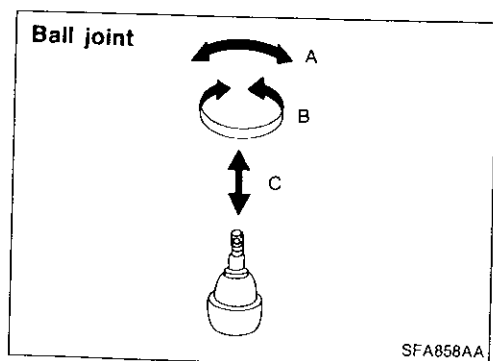

##### Lower ball joint

- Check ball joint for play. Replace transverse link assembly in any of the following cases: Ball stud is worn, play in axial direction is excessive or joint is hard to swing. Before checking, turn ball joint at least 10 revolutions so that ball joint is properly broken in.
  - Swinging force "A":** Refer to SDS (FA-15). (measuring point: cotter pin hole of ball stud)
  - Turning torque "B":** Refer to SDS (FA-15).
  - Vertical end play "C":** Refer to SDS (FA-15).
- Check dust cover for damage. Replace it if necessary.

## SERVICE DATA AND SPECIFICATIONS (SDS)

### General Specifications

#### COIL SPRING

	Unit: mm (in)
Applied model	All
Wire diameter	13.1 (0.516)
Coil outer diameter	183.2 (7.21)
Free length	310 (12.20)
Identification color	White x 1, White x 2

#### STRUT

	Unit: mm (in)
Applied model	All
Piston rod diameter	22 (0.87)

#### FRONT STABILIZER BAR

	Unit: mm (in)
Applied model	All
Stabilizer diameter	26.5 (1.043)
Identification color	Red

### Inspection and Adjustment

#### WHEEL ALIGNMENT (Unladen\*1)

Applied model	Europe	Australia	Except Europe and Australia
Camber degree	-1°35' to -0°05'	-1°30' to 0°	
Caster degree	5°55' - 7°25'	6°00' - 7°30'	
Toe-in			
A - B	1 - 3	1.5 - 3.5	
mm (in)	(0.04 - 0.12)	(0.059 - 0.138)	
Total angle 2θ degree	5' - 16'	8' - 19'	
Kingpin inclination degree	12°55' - 14°25'		12°50' - 14°20'
Front wheel turning angle			
Full turn*2 inside/outside degree	39° - 43°/ 33°05'	39° - 43°/33°10'	

\*1: Fuel, radiator coolant and engine oil full. Spare tire, jack, hand tools and mats in designated positions.

\*2: On power steering models, wheel turning force (at circumference of steering wheel) of 98 to 147 N (10 to 15 kg, 22 to 33 lb) with engine at idle.

#### WHEEL BEARING

Wheel bearing axial end play mm (in)	0.05 (0.0020) or less
Wheel bearing lock nut Tightening torque N·m (kg·m, ft·lb)	206 - 284 (21 - 29, 152 - 210)

#### LOWER BALL JOINT

Swinging force "A" (Measuring point: cotter pin hole of bail stud) N (kg, lb)	23.5 - 79.4 (2.4 - 8.1, 5.3 - 17.9)
Turning torque "B" N·m (kg·cm, in·lb)	1.5 - 4.9 (15 - 50, 13 - 43)
Vertical end play "C" mm (in)	0 (0)

#### WHEEL RUNOUT (Radial and lateral)

Wheel type	Radial runout	Lateral runout
Aluminum wheel mm (in)	0.3 (0.012) or less	
Steel wheel mm (in)	0.7 (0.028) or less	1.0 (0.039) or less

# REAR AXLE & REAR SUSPENSION

## SECTION **RA**

### CONTENTS

<b>PRECAUTIONS AND PREPARATION</b> .....	2	<b>REAR AXLE</b> .....	7
Precautions .....	2	Wheel Hub and Axle Housing .....	7
Special Service Tools .....	2	Drive Shaft .....	11
Commercial Service Tools .....	3	<b>REAR SUSPENSION</b> .....	17
<b>REAR SUSPENSION SYSTEM</b> .....	4	Removal and Installation .....	18
<b>ON-VEHICLE SERVICE</b> .....	5	Coil Spring and Shock Absorber .....	19
Rear Axle and Rear Suspension Parts .....	5	Multi-link and Lower Ball Joint .....	20
Rear Wheel Bearing .....	5	Stabilizer Bar .....	21
Rear Wheel Alignment .....	5	<b>SERVICE DATA AND SPECIFICATIONS (SDS)</b> .....	22
Drive Shaft .....	6	General Specifications .....	22
		Inspection and Adjustment .....	23



## PRECAUTIONS AND PREPARATION

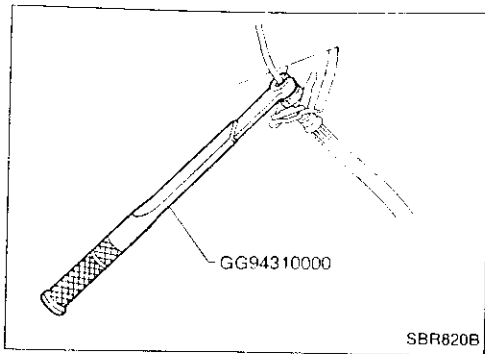

### Precautions

- When installing rubber parts, final tightening must be carried out under unladen condition\* with tires on ground.
- \*: Fuel, radiator coolant and engine oil full. Spare tire, jack, hand tools and mats in designated positions.
- Use flare nut wrench when removing or installing brake tubes.
- After installing removed suspension parts, check wheel alignment and adjust if necessary.
- Always torque brake lines when installing.
- Do not jack up at the lower arm.

### Special Service Tools

Tool number Tool name	Description
HT71780000 Spring compressor	<div style="text-align: right;">Removing and installing coil spring</div> <p style="text-align: center;">NT144</p>
ST35652000 Strut attachment	<div style="text-align: right;">Fixing strut assembly</div> <p style="text-align: center;">NT145</p>
ST30031000 Bearing puller	<div style="text-align: right;">Removing inner race of wheel bearing</div> <p style="text-align: center;">NT412</p> <p style="text-align: right;">a: 50 mm (1.97 in) dia.</p>
ST38280000 Arm bushing remover	<div style="text-align: right;">Removing and installing bushing of rear axle housing</div> <p style="text-align: center;">NT157</p>
GG94310000 Flare nut torque wrench	<div style="text-align: right;">Removing and installing brake piping</div> <p style="text-align: center;">NT406</p> <p style="text-align: right;">a: 10 mm (0.39 in) dia.</p>

## PRECAUTIONS AND PREPARATION

### Commercial Service Tools

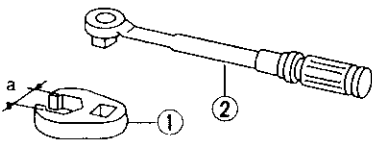
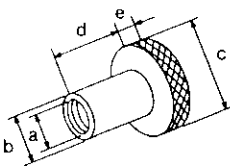
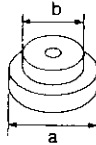
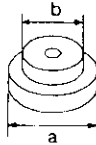
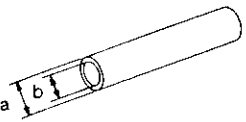
Tool name	Description
Equivalent to GG94310000 ① Flare nut crows foot ② Torque wrench	<div style="display: flex; justify-content: space-between;"> <div style="width: 30%;">  </div> <div style="width: 60%;"> <p>Removing and installing brake piping</p> <p>NT360</p> <p>a: 10 mm (0.39 in)</p> </div> </div>
Attachment Wheel alignment	<div style="display: flex; justify-content: space-between;"> <div style="width: 30%;">  </div> <div style="width: 60%;"> <p>Measure rear wheel alignment</p> <p>NT148</p> <p>a: Screw M24 x 1.5                      b: 35 mm (1.38 in) dia.                      c: 65 mm (2.56 in) dia.                      d: 56 mm (2.20 in)                      e: 12 mm (0.47 in)</p> </div> </div>
Rear wheel hub drift	<div style="display: flex; justify-content: space-between;"> <div style="width: 30%;">  </div> <div style="width: 60%;"> <p>Installing wheel bearing</p> <p>NT073</p> <p>a: 49 mm (1.93 in) dia.                      b: 41 mm (1.61 in) dia.</p> </div> </div>
Wheel bearing drift	<div style="display: flex; justify-content: space-between;"> <div style="width: 30%;">  </div> <div style="width: 60%;"> <p>Removing rear wheel hub</p> <p>NT073</p> <p>a: 40 mm (1.57 in) dia.                      b: 26 mm (1.02 in) dia.</p> </div> </div>
Rear drive shaft plug seal drift	<div style="display: flex; justify-content: space-between;"> <div style="width: 30%;">  </div> <div style="width: 60%;"> <p>Installing rear drive shaft plug seal</p> <p>NT065</p> <p>a: 85 mm (3.35 in) dia.                      b: 67 mm (2.64 in) dia.</p> </div> </div>

## ON-VEHICLE SERVICE

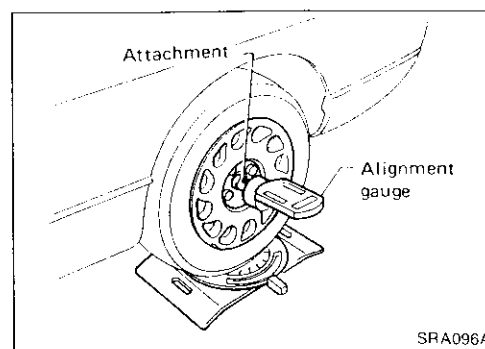
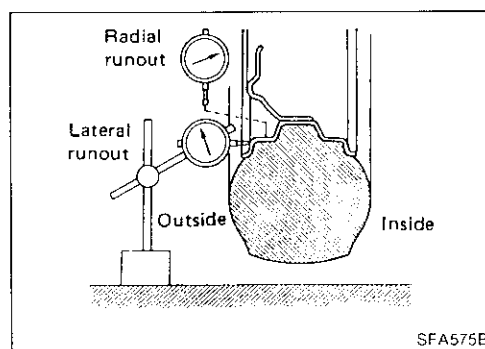
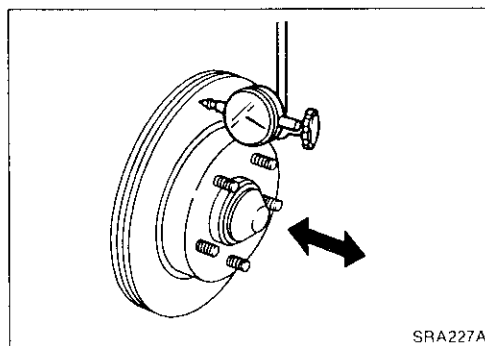
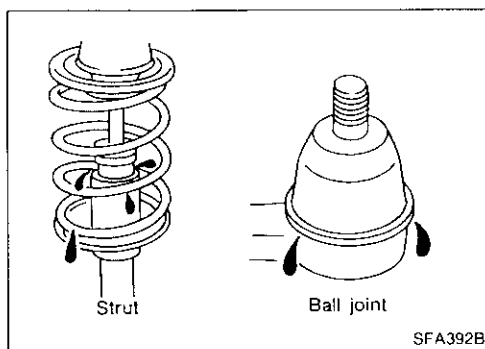
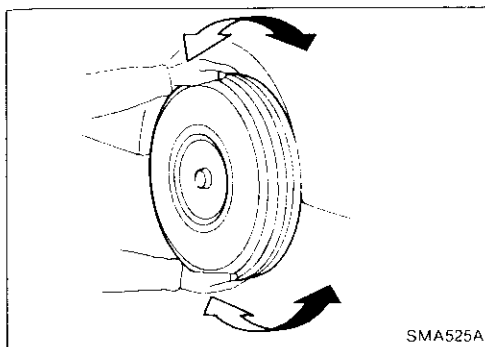

### Rear Axle and Rear Suspension Parts

Check axle and suspension parts for looseness, wear or damage.

- Shake each rear wheel.
- Retighten all axle and suspension nuts and bolts to the specified torque.

**Tightening torque:**

**Refer to REAR SUSPENSION (RA-17).**

- Make sure that cotter pins are inserted.
- Check shock absorber for oil leakage or other damage.
- Check suspension lower ball joint for excessive play.
- Check suspension ball joint for grease leakage and ball joint dust cover for cracks or other damage.

### Rear Wheel Bearing

- Check wheel bearings smooth operation.
- Check axial end play.

**Axial end play:**

**0.05 mm (0.0020 in) or less**

- If out of specification or wheel bearing does not turn smoothly, replace wheel bearing assembly.  
Refer to REAR AXLE — Wheel Hub and Axle Housing (RA-7).

### Rear Wheel Alignment

Before checking rear wheel alignment, be sure to make a preliminary inspection.

#### PRELIMINARY INSPECTION

Make following checks. Adjust, repair or replace if necessary.

- Check tires for wear and for improper inflation.
- Check rear wheel bearings for looseness.
- Check wheel runout.  
Refer to SDS in FA section.
- Check that rear shock absorber works properly.
- Check rear axle and rear suspension parts for looseness.
- Check vehicle posture (Unladen).  
("Unladen": Fuel tank, radiator and engine oil full. Spare tire, jack, hand tools and mats in designated positions.)

#### CAMBER

Measure camber of both right and left wheels with a suitable alignment gauge and adjust in accordance with the following procedures.

**Camber:**

**Refer to SDS (RA-23).**

SEC. 431

When installing rubber parts, final tightening must be carried out under unladen condition\* with tires on ground.

\* Fuel, radiator coolant and engine oil full. Spare tire, jack, hand tools and mats in designated positions.

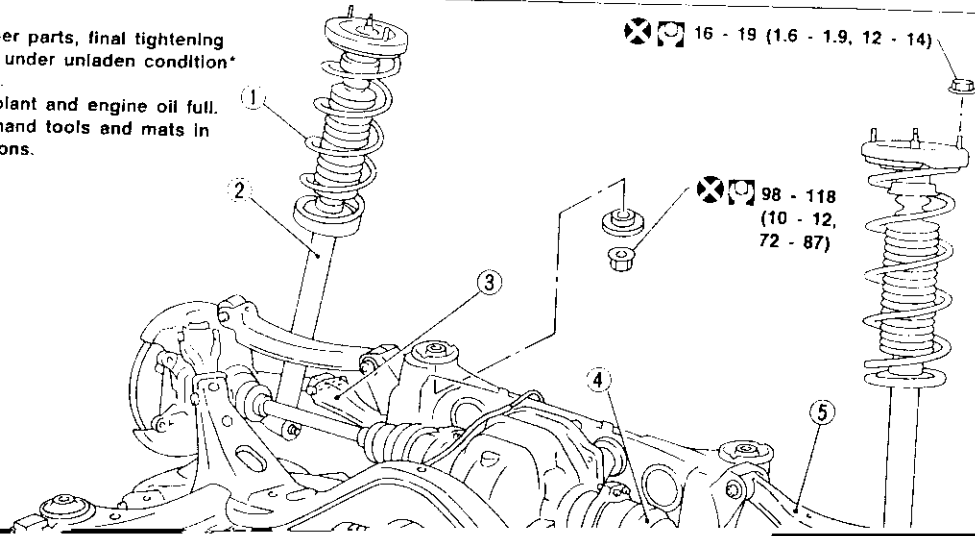



## ON-VEHICLE SERVICE

### Rear Wheel Alignment (Cont'd)

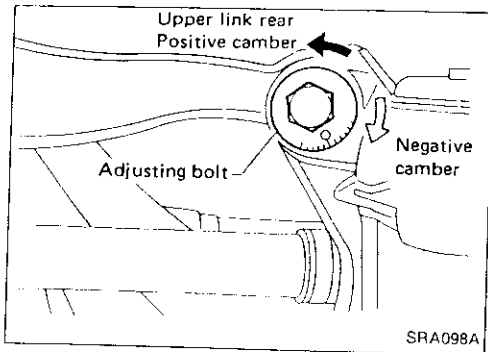

- If camber is not within specification, adjust by turning the adjusting bolt.
1. Turn the adjusting bolt to adjust.  
**Camber changes about 4' with each graduation of the adjusting bolt.**
  2. Tighten to the specified torque.  
 $\left[ \begin{array}{c} \text{Torque} \\ \text{Symbol} \end{array} \right]: 69 - 88 \text{ N}\cdot\text{m}$   
 (7.0 - 9.0 kg-m, 51 - 65 ft-lb)

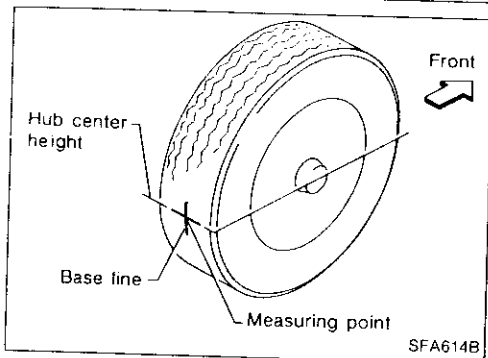

### TOE-IN

Measure toe-in using following procedure. If out of specification, inspect and replace any damaged or worn rear suspension parts.

#### WARNING:

- Perform following procedure always on a flat surface.
  - Make sure that no person is in front of the vehicle before pushing it.
1. Move rear of vehicle up and down to stabilize the posture.
  2. Push the vehicle straight ahead about 5 m (196.9 in).
  3. Put a mark on base line of the tread (rear side) at the same height of hub center to be a measuring point.
  4. Measure distance "A" (rear side).
  5. Push the vehicle slowly ahead to turn the wheels around 180 degrees.

If the wheels have passed 180 degrees, try the above procedure again from the beginning. Never push vehicle backward.

6. Measure distance "B" (front side).

Toe-in (A - B):

Refer to SDS (RA-23).

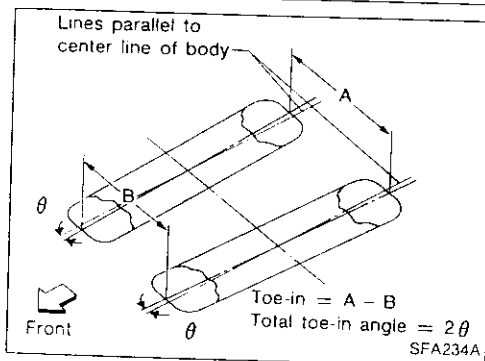

7. Adjust toe-in by turning adjusting bolts.

Toe changes about 1.3 mm (0.051 in) [One side] with each graduation of the adjusting bolt.

8. Tighten to the specified torque.

$\left[ \begin{array}{c} \text{Torque} \\ \text{Symbol} \end{array} \right]: 69 - 88 \text{ N}\cdot\text{m}$

(7.0 - 9.0 kg-m, 51 - 65 ft-lb)

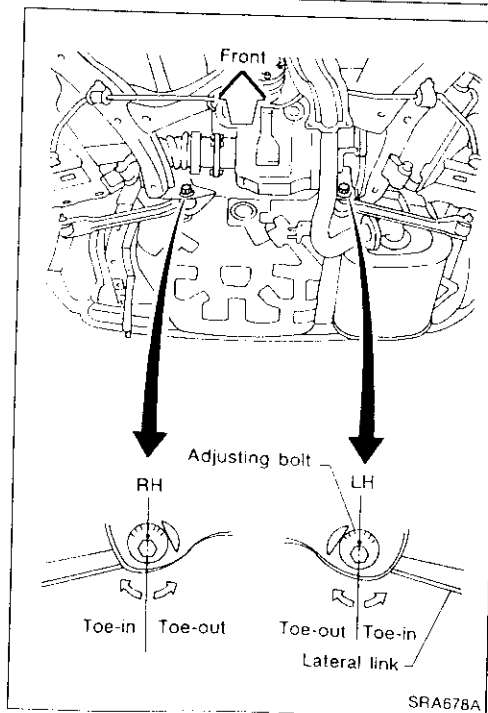

### Drive Shaft

Check boot and drive shaft for cracks, wear, damage or grease leakage.

## REAR AXLE

### Wheel Hub and Axle Housing

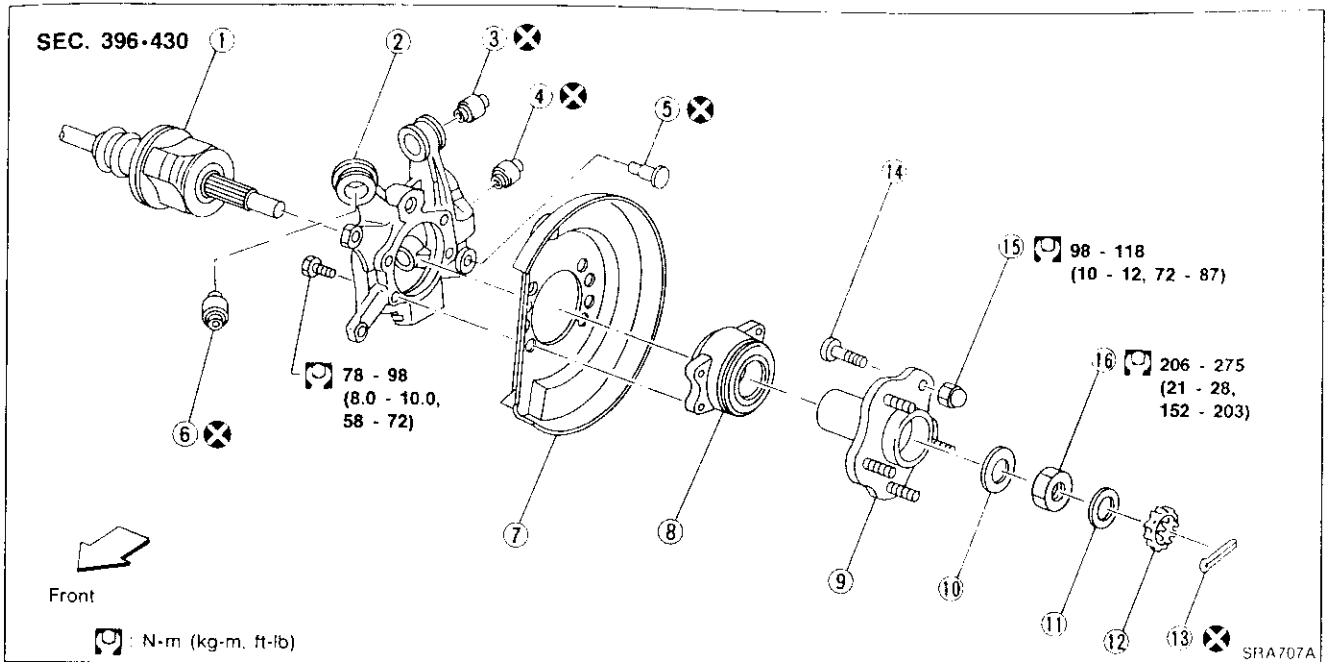

- |                      |                             |                          |
|----------------------|-----------------------------|--------------------------|
| ① Drive shaft        | ⑦ Baffle plate              | ⑫ Adjusting cap          |
| ② Axle housing       | ⑧ Wheel bearing with flange | ⑬ Cotter pin             |
| ③ Bushing            | ⑨ Wheel hub                 | ⑭ Hub bolt               |
| ④ Bushing            | ⑩ Plain washer              | ⑮ Wheel nut              |
| ⑤ Shock absorber pin | ⑪ Insulator                 | ⑯ Wheel bearing lock nut |
| ⑥ Bushing            |                             |                          |

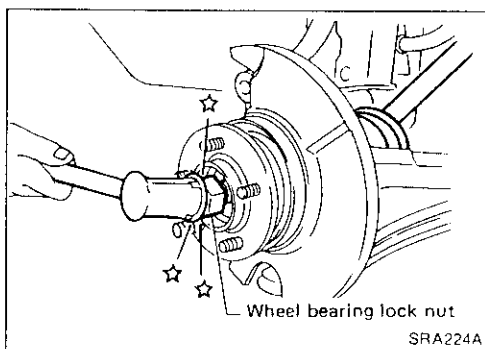

#### REMOVAL

1. Remove wheel bearing lock nut.
2. Separate drive shaft from axle housing by lightly tapping it. If it is hard to remove use puller.

**When removing drive shaft, cover boots with shop towel to prevent them from being damaged.**

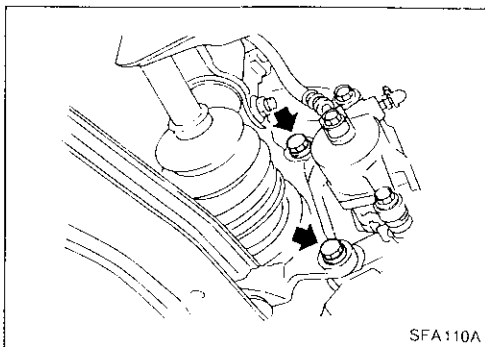

3. Remove brake caliper assembly and rotor.  
**Suspend caliper assembly with wire so as not to stretch brake hose.**  
**Be careful not to depress brake pedal or piston will pop out.**

## REAR AXLE

### Wheel Hub and Axle Housing (Cont'd)

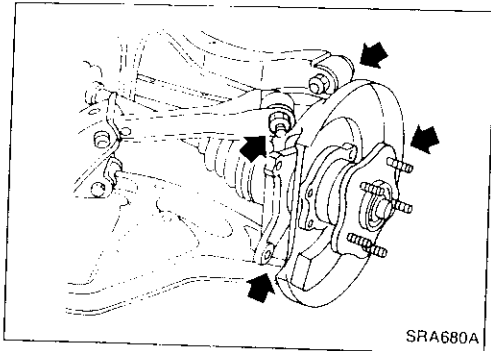

4. Remove axle housing.

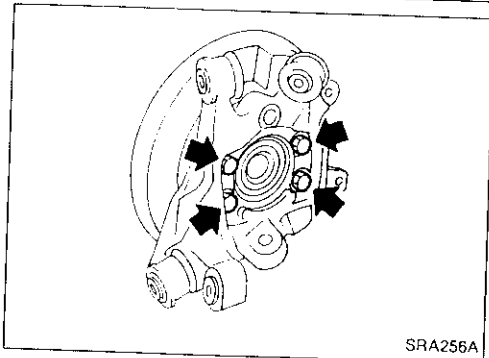

5. Remove wheel bearing with flange, and wheel hub from axle housing.

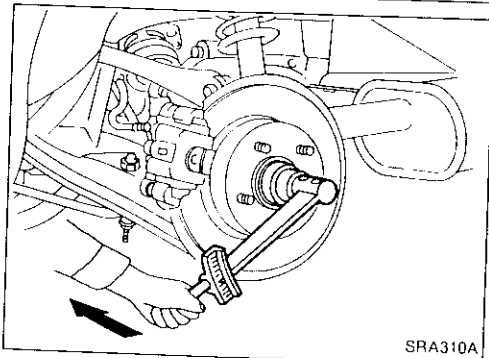

### INSTALLATION

1. Install axle housing with wheel hub.
2. Tighten wheel bearing lock nut.  
Before tightening, apply oil to threaded portion of rear spindle and both sides of plain washer.

: 206 - 275 N·m  
(21 - 28 kg-m, 152 - 203 ft-lb)

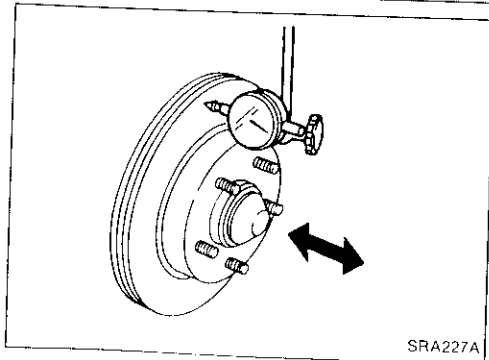

3. Check wheel bearing axial end play.  
**Axial end play: 0.05 mm (0.0020 in) or less**  
Make sure that wheel bearings operate smoothly.
4. Check toe-in — Refer to ON-VEHICLE SERVICE (RA-6).

## REAR AXLE

### Wheel Hub and Axle Housing (Cont'd)

#### DISASSEMBLY

##### CAUTION:

Wheel bearing with flange usually does not require maintenance. If any of the following symptoms are noted, replace wheel bearing assembly (including flange, and inner and outer seals).

- Growling noise is emitted from wheel bearing during operation.
- Wheel hub bearing drags or turns roughly. This occurs when turning hub by hand after bearing lock nut is tightened to specified torque.
- After wheel bearing is removed from hub.

#### Wheel hub

Remove wheel bearing (with flange) and wheel hub as one unit from axle housing before disassembling.

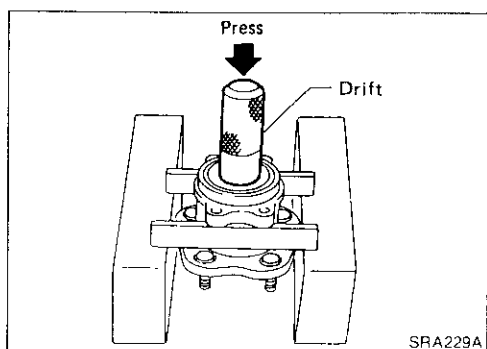
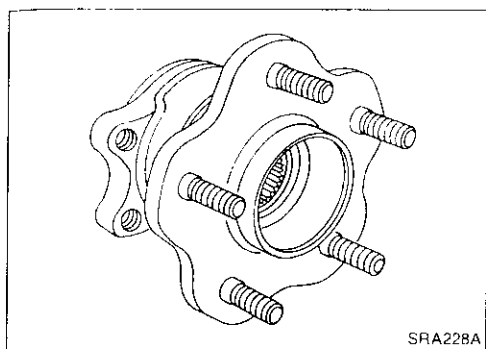

#### Wheel bearing

1. Using a press and drift as shown in figure at left, press wheel bearing out.
2. Discard old wheel bearing assembly. Replace with a new one.

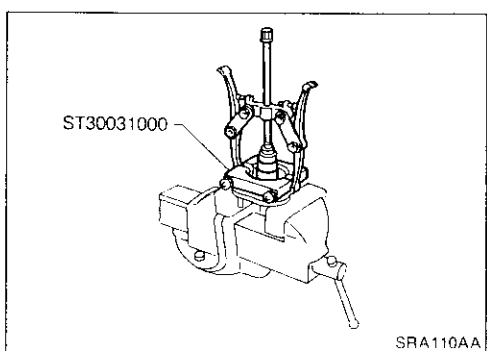

3. Remove inner race from hub using a bearing replacer/puller.

##### CAUTION:

- Do not reuse old inner race although it is of the same brand as the bearing assembly.
- Do not replace grease seals as single parts.

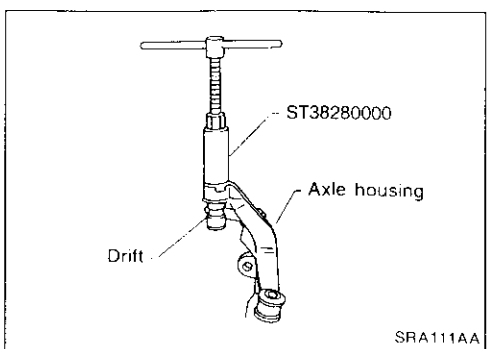

#### Axle housing

1. Attach a drift on outer shell of bushing as shown in figure at left. Remove bushing using arm bushing remover.

When placing axle housing in a vise, use wooden blocks or copper plates as pads.

RA

## REAR AXLE

### Wheel Hub and Axle Housing (Cont'd)

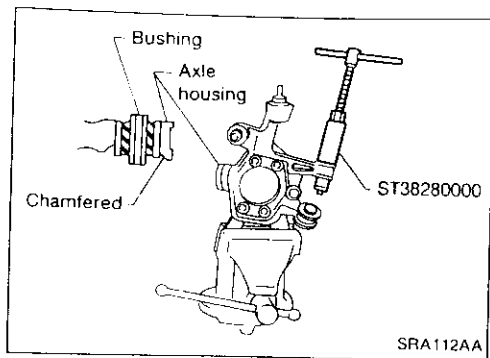

2. Ensure axle housing bore is free from scratches or deformities before pressing bushing into it.
3. Attach bushing to chamfered bore end of axle housing. Then press it until it is flush with end face of axle housing.

### INSPECTION

#### Wheel hub and axle housing

- Check wheel hub and axle housing for cracks by using a magnetic exploration or dyeing test.
- Check wheel bearing for damage, seizure, rust or rough operation.
- Check rubber bushing for wear or other damage. Replace if necessary.

### ASSEMBLY

Place hub on a block. Attach a drift to inner race of wheel bearing and press it into hub as shown. **Be careful not to damage grease seal.**

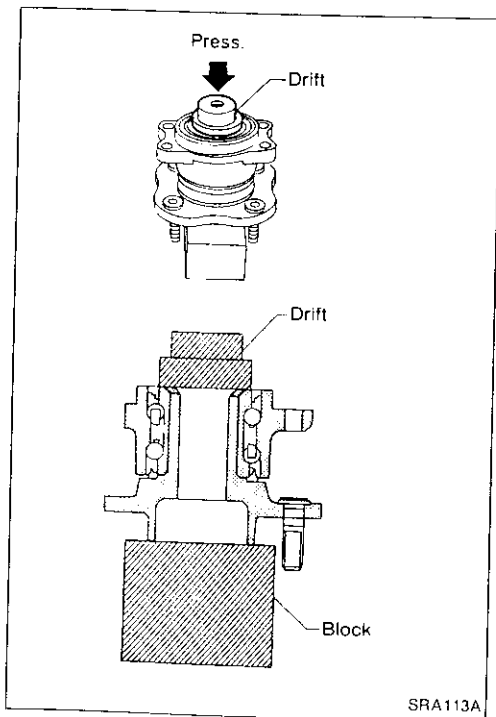

# REAR AXLE

## Drive Shaft

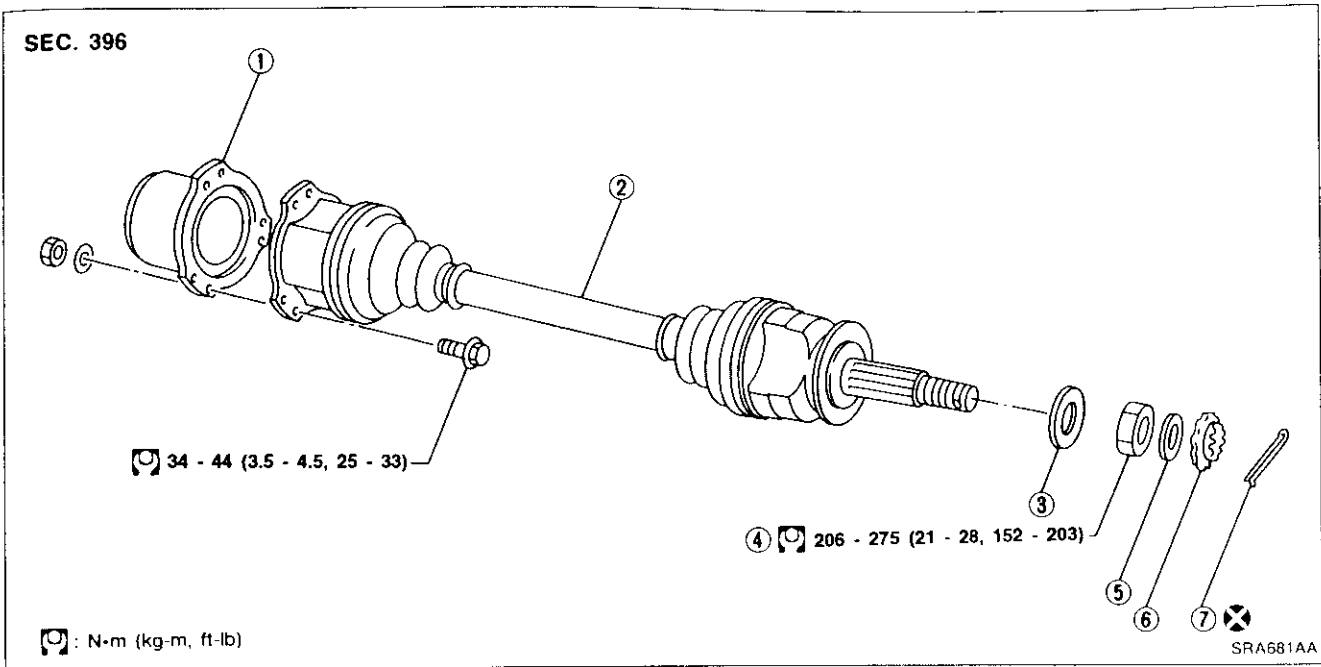

④ Wheel bearing lock nut

## REAR AXLE Drive Shaft (Cont'd) COMPONENTS

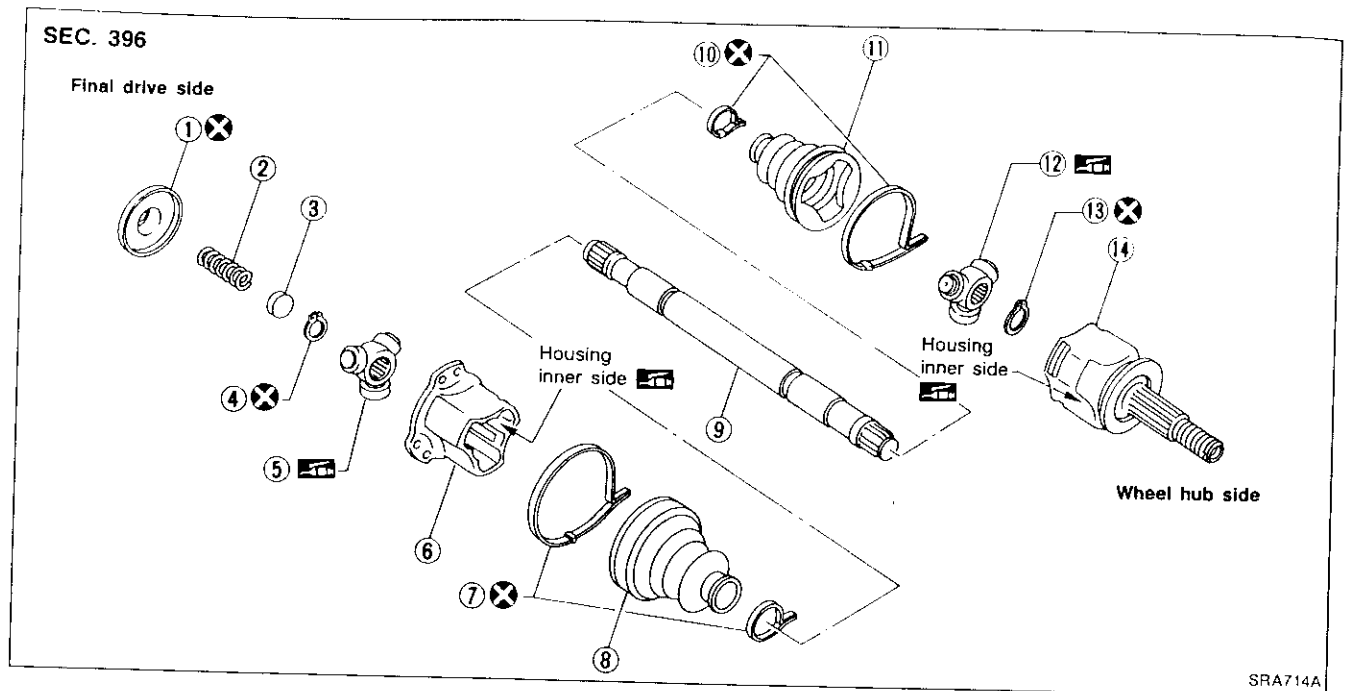

- ① Plug seal
- ② Spring
- ③ Spring cap
- ④ Snap ring
- ⑤ Spider assembly

- ⑥ Slide joint housing
- ⑦ Boot band
- ⑧ Boot
- ⑨ Drive shaft
- ⑩ Boot band

- ⑪ Boot
- ⑫ Spider assembly
- ⑬ Snap ring
- ⑭ Housing with shaft

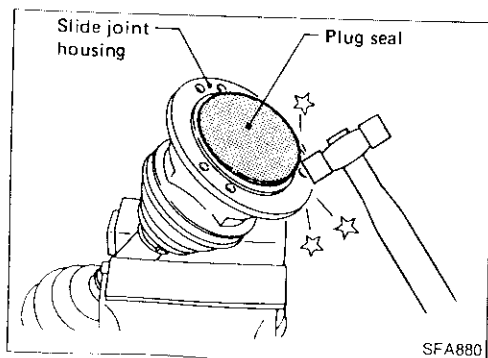

### DISASSEMBLY

#### Final drive side

1. Remove plug seal from slide joint housing by lightly tapping around slide joint housing.

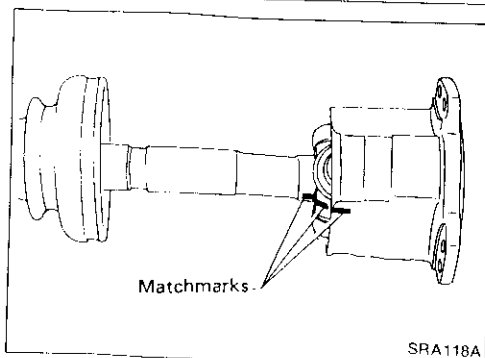

2. Remove boot bands.
3. Put matchmarks on slide joint housing and drive shaft before separating joint assembly.
4. Put matchmarks on spider assembly and drive shaft.

## REAR AXLE

### Drive Shaft (Cont'd)

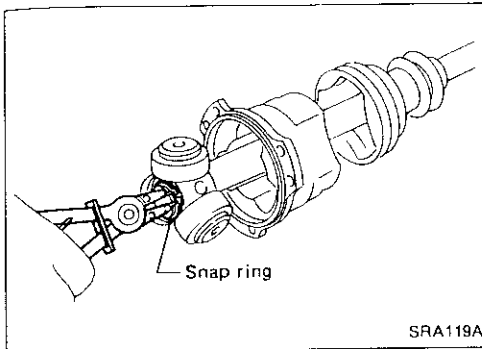

5. Pry off snap ring, then remove spider assembly.

**CAUTION:**

**Do not disassemble spider assembly.**

6. Draw out slide joint housing.

7. Draw out boot.

**Cover drive shaft serration with tape to prevent damage to the boot.**

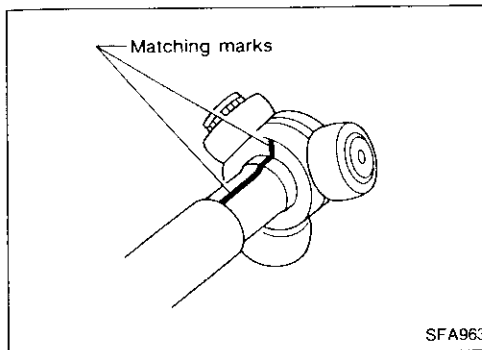

### Wheel side

1. Remove boot bands.

2. Put matchmarks on housing together with shaft and drive shaft before separating joint assembly.

3. Put matchmarks on spider assembly and drive shaft.

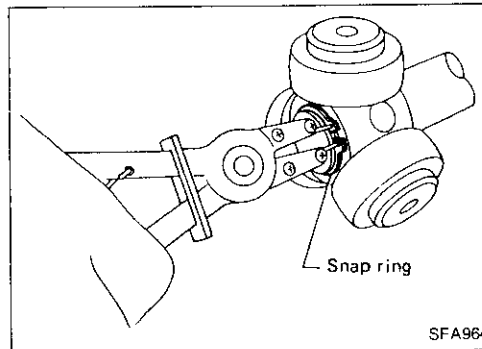

4. Pry off snap ring, then remove spider assembly.

**CAUTION:**

**Do not disassemble spider assembly.**

5. Draw out boot.

**Cover drive shaft serration with tape to prevent damage to the boot.**

### INSPECTION

Thoroughly clean all parts in cleaning solvent, and dry with compressed air. Check parts for deformation or other damage.

#### Drive shaft

Replace drive shaft if it is twisted or cracked.

#### Boot

Check boot for fatigue, cracks, or wear. Replace boot with new boot bands.



## REAR AXLE

### Drive Shaft (Cont'd)

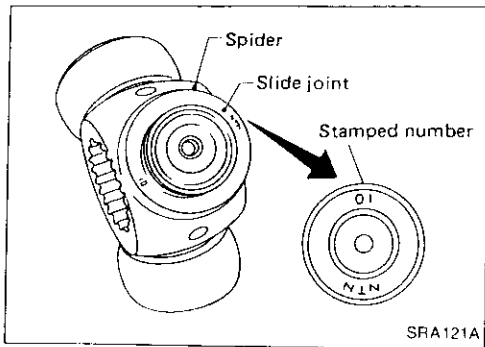

#### Joint assembly

- Check spider assembly for bearing, roller and washer damage. Replace spider assembly if necessary.
- Check housing for any damage. Replace housing set and spider assembly, if necessary.
- When replacing only spider assembly, select a new spider assembly from among those listed in table below. Ensure the number stamped on sliding joint is the same as that stamped on new part.

**Housing alone cannot be replaced. It must be replaced together with spider assembly.**

Stamped number	Part No.
00	39720 10V10
01	39720 10V11
02	39720 10V12

#### ASSEMBLY

- After drive shaft has been assembled, ensure it moves smoothly over its entire range without binding.
- Use **NISSAN GENUINE GREASE** or equivalent after every overhaul.

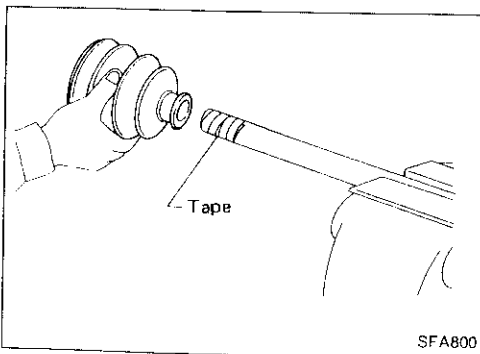

#### Wheel side

1. Install new small boot band and boot on drive shaft.  
**Cover drive shaft serration with tape to prevent damage to boot during installation.**

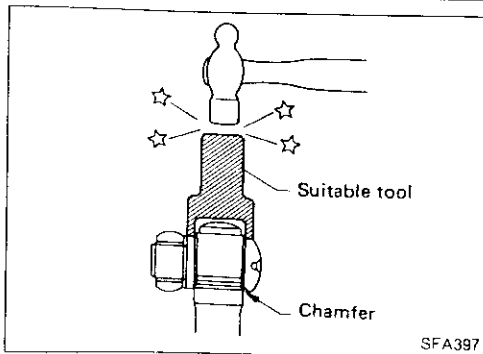

2. Install spider assembly securely, making sure marks are properly aligned.  
**Press-fit with spider assembly serration chamfer facing shaft.**
3. Install new snap ring.

## REAR AXLE

### Drive Shaft (Cont'd)

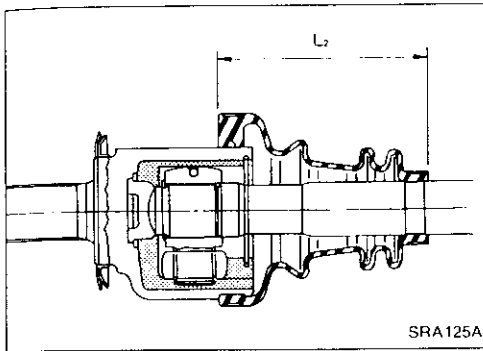

4. Pack drive shaft with specified amount of grease.

**Specified amount of grease:**

**135 - 145 g (4.76 - 5.11 oz)**

5. Install slide joint housing, then install new snap ring.
6. Set boot so that it does not swell and deform when its length is " $L_2$ ".

**Length " $L_2$ ":**

**95 - 97 mm (3.74 - 3.82 in)**

**Make sure that boot is properly installed on the drive shaft groove.**

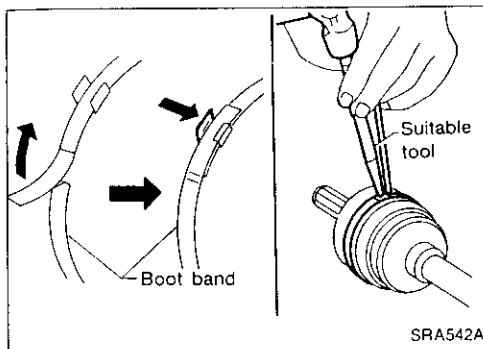

7. Lock new larger and smaller boot bands securely with a suitable tool.

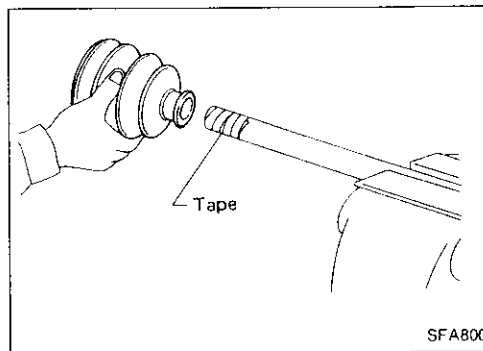

### Final drive side

1. Install new small boot band, boot and slide joint housing to drive shaft.

**Cover drive shaft serration with tape to prevent damage to boot during installation.**

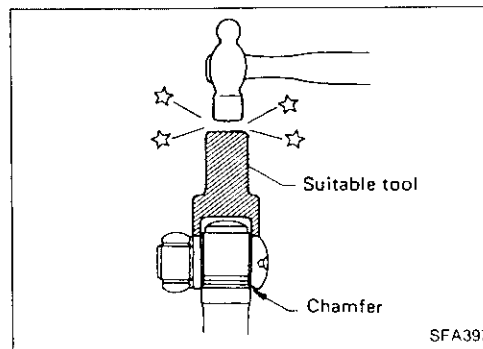

2. Install spider assembly securely, making sure marks are properly aligned.

**Press-fit with spider assembly serration chamfer facing shaft.**

3. Install new snap ring.

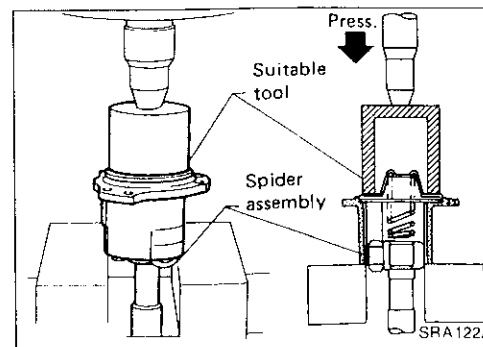

4. Install coil spring, spring cap and new plug seal to slide joint housing. Press plug seal.

**Apply sealant to mating surface of plug seal.**

### CAUTION:

- a. When pressing plug seal into place, hold it horizontally. This prevents spring inside it from tilting or falling down.

RA

## REAR AXLE

### Drive Shaft (Cont'd)

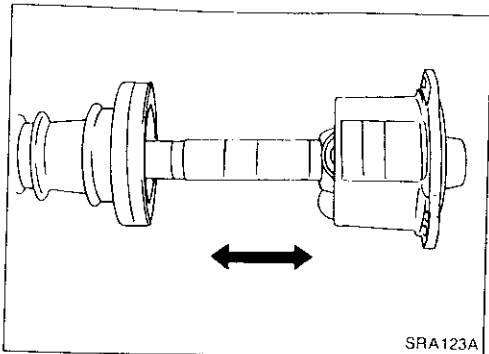

SRA123A

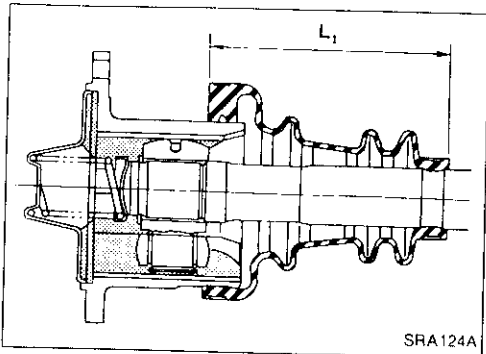

SRA124A

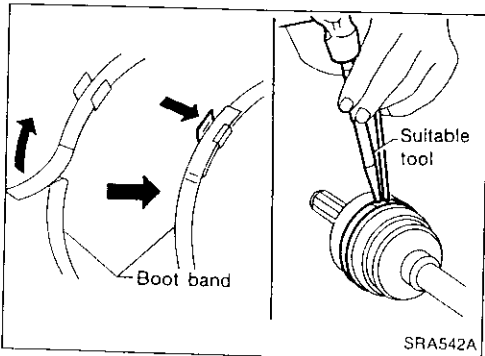

SRA542A

- b. Move shaft in axial direction to ensure that spring is installed properly. If shaft drags or if spring is not properly installed, replace plug seal with a new one.

5. Pack drive shaft with specified amount of grease.

**Specified amount of grease:**

**155 - 165 g (5.47 - 5.82 oz)**

6. Set boot so that it does not swell and deform when its length is " $L_1$ ".

**Length " $L_1$ ":**

**95 - 97 mm (3.74 - 3.82 in)**

**Make sure that boot is properly installed on the drive shaft groove.**

7. Lock new larger boot band securely with a suitable tool, then lock new smaller boot band.

# REAR SUSPENSION

## SEC. 380-396-431

### CAUTION:

Do not jack up at lower link.  
When installing rubber parts, final tightening must be carried out under unladen condition\* with tires on ground.

\* Fuel, radiator coolant and engine oil full.  
Spare tire, jack, hand tools and mats in designated positions.

⊗ ⊕ 12 - 14  
(1.2 - 1.4,  
9 - 10)

⊗ ⊕ 69 - 88  
(7.0 - 9.0,  
51 - 65)

⊗ ⊕ 77 - 98  
(7.9 - 10.0, 57 - 72)

⊗ ⊕ 98 - 118  
(10 - 12, 72 - 87)

⊗ ⊕ 16 - 19  
(1.6 - 1.9,  
12 - 14)

⊗ ⊕ 18 - 24  
(1.8 - 2.4,  
13 - 17)

⊗ ⊕ 77 - 98  
(7.9 - 10.0,  
57 - 72)

⊗ ⊕ 98 - 118  
(10 - 12, 72 - 87)

⊗ ⊕ 98 - 118  
(10 - 12,  
72 - 87)

⊗ ⊕ 69 - 88  
(7.0 - 9.0, 51 - 65)

⊗ ⊕ 9 - 12  
(0.9 - 1.2,  
6.5 - 8.7)

⊗ ⊕ 77 - 98  
(7.9 - 10.0, 57 - 72)

⊗ ⊕ 43 - 55  
(4.4 - 5.6, 32 - 41)

⊗ ⊕ 77 - 98  
(7.9 - 10.0,  
57 - 72)

⊗ ⊕ 71 - 86  
(7.2 - 8.8,  
52 - 64)

⊗ ⊕ 98 - 118  
(10 - 12, 72 - 87)

⊗ ⊕ 98 - 118  
(10 - 12,  
72 - 87)

⊗ ⊕ 34 - 44  
(3.5 - 4.5, 25 - 33)

⊗ ⊕ 9 - 12 (0.9 - 1.2, 6.5 - 8.7)

⊗ ⊕ 206 - 275  
(21 - 28, 152 - 203)

⊗ ⊕ : N·m (kg·m, ft·lb)

⊗ ⊕ 43 - 55 (4.4 - 5.6, 32 - 41)

SRA708A

- |                                 |                     |                           |
|---------------------------------|---------------------|---------------------------|
| ① Cap                           | ⑩ Coil spring       | ⑲ Drive shaft             |
| ② Gasket                        | ⑪ Shock absorber    | ⑳ Connecting rod          |
| ③ Upper plate                   | ⑫ Suspension member | ㉑ Final drive             |
| ④ Bushing                       | ⑬ Rear upper link   | ㉒ Stabilizer bar          |
| ⑤ Upper spring seat             | ⑭ Front upper link  | ㉓ Bushing                 |
| ⑥ Upper rubber seat             | ⑮ Lateral link      | ㉔ Member stay             |
| ⑦ Bushing                       | ⑯ Lower arm         | ㉕ Insulator               |
| ⑧ Plate                         | ⑰ Protector         | ㉖ Adjusting cap           |
| ⑨ Bumper rubber with dust cover | ⑱ Axle housing      | ㉗ Dynamic damper assembly |

## REAR SUSPENSION

### Removal and Installation

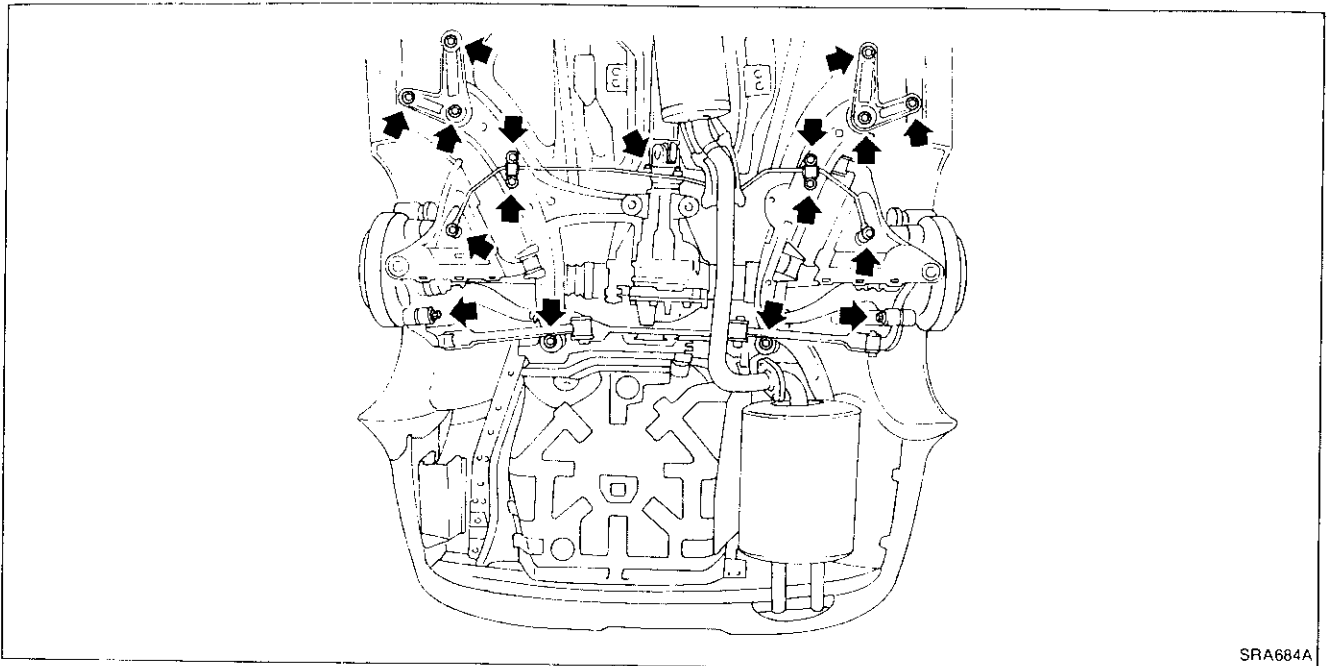

SRA684A

#### CAUTION:

Before removing the rear suspension assembly, disconnect the ABS sensor from the assembly. Then move it away from the rear suspension assembly. Failure to do so may result in damages to the sensor wires, making the sensor inoperative.

1. Remove exhaust tube.
2. Disconnect propeller shaft rear end.
3. Disconnect hand brake wire front end.

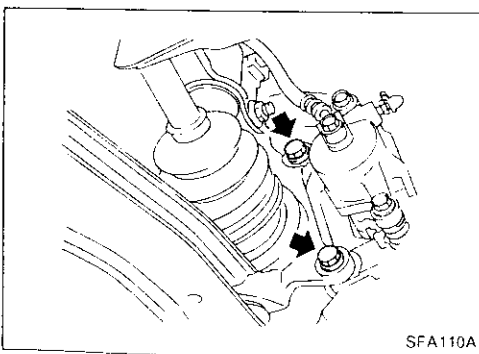

SFA110A

4. Remove brake caliper assembly.

Suspend caliper assembly with wire so as not to stretch brake hose.

Be careful not to depress brake pedal, or piston will pop out.

5. Remove rear wheel hub, brake disc, and brake drum.

## REAR SUSPENSION

### Coil Spring and Shock Absorber

#### REMOVAL

Remove shock absorber upper and lower fixing nuts.  
**Do not remove piston rod lock nut on vehicle.**

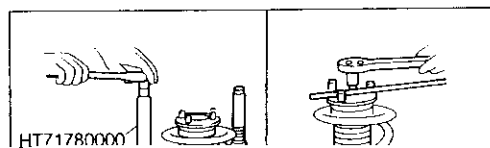

#### DISASSEMBLY

1. Set shock absorber on vise with attachment, then loosen piston rod lock nut.

**Do not remove piston rod lock nut.**

## REAR SUSPENSION

### Coil Spring and Shock Absorber (Cont'd) ASSEMBLY

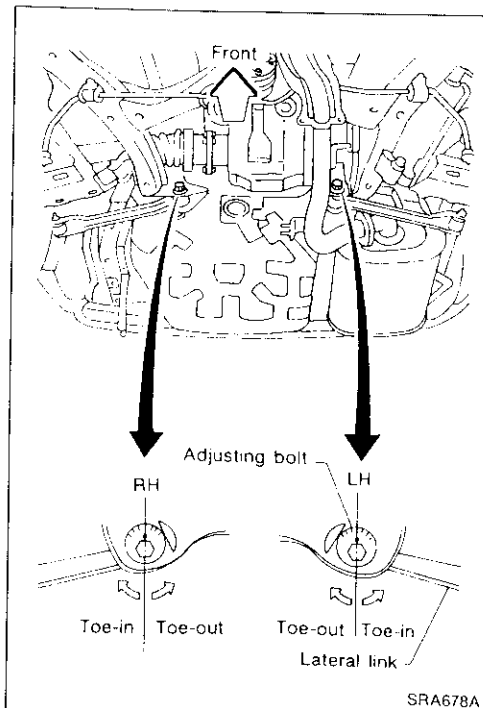
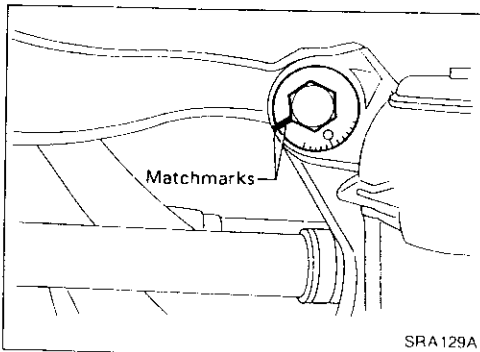
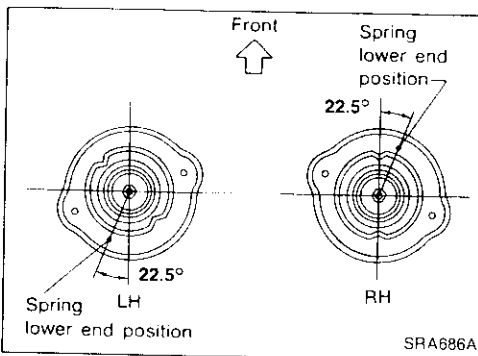
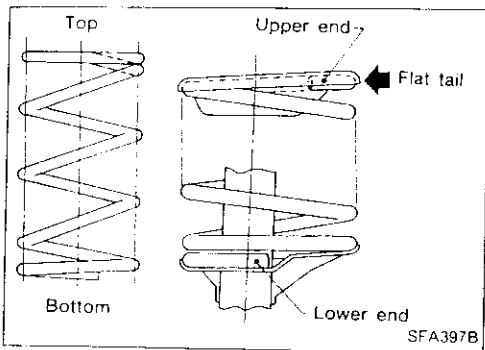

- When installing coil spring, be careful not to reverse top and bottom direction. (Top end is flat.)
- When installing coil spring on strut, it must be positioned as shown in figure at left.

- When installing upper spring seat, make sure that it is positioned as shown.

### Multi-link and Lower Ball Joint

#### REMOVAL AND INSTALLATION

- Refer to "Removal and Installation" of REAR SUSPENSION (RA-18).
- **Before removing, put matchmarks on adjusting pin.**
- When installing, final tightening must be carried out at curb weight with tires on ground.
- After installation, check wheel alignment. Refer to "Rear Wheel Alignment" of ON-VEHICLE SERVICE (RA-5).

## REAR SUSPENSION

### Multi-link and Lower Ball Joint (Cont'd) INSPECTION

#### Rear suspension member

Replace suspension member assembly if cracked or deformed or if any part (insulator, for example) is damaged.

#### Upper and lower links

Replace upper or lower link as required if cracked or deformed or if bushing is damaged.

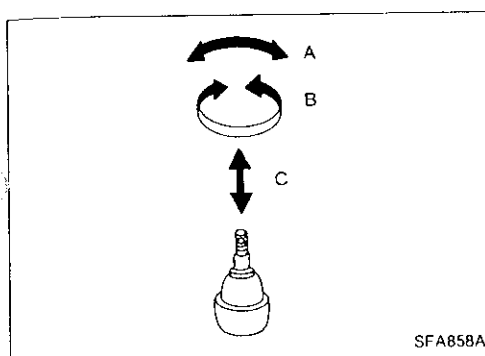

#### Lower ball joint

- Check ball joint for play. Replace transverse link assembly if any of the following cases occur. Ball stud is worn, play in axial direction is excessive or joint is hard to swing.

#### Swing force and turning torque

Before checking, turn ball joint at least 10 revolutions so that ball joint is properly broken in.

##### Swing force "A":

(measuring point: cotter pin hole of ball stud)

7.8 - 54.9 N (0.8 - 5.6 kg, 1.8 - 12.3 lb)

##### Turning torque "B":

0.5 - 3.4 N·m (5 - 35 kg-cm, 4.3 - 30.4 in-lb)

##### Vertical end play "C":

0 mm (0 in)

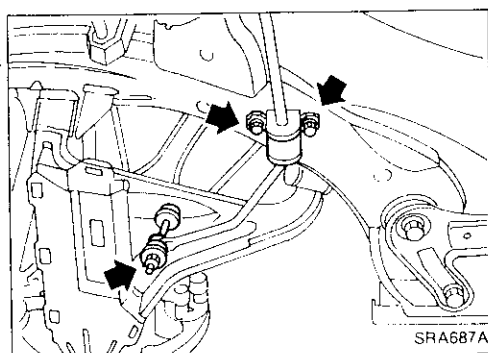

#### Stabilizer Bar

##### REMOVAL

- Remove connecting rod and clamp.

##### INSPECTION

- Check stabilizer bar for deformation or cracks. Replace if necessary.
- Check rubber bushings for deterioration or cracks. Replace if necessary.

##### INSTALLATION

When installing connecting rod, make sure direction is correct (as shown at left).

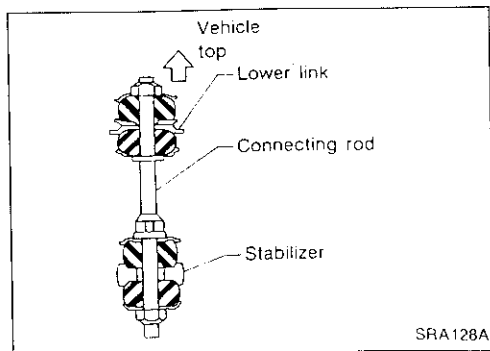



## SERVICE DATA AND SPECIFICATIONS (SDS)

### General Specifications

#### COIL SPRING

Unit: mm (in)	
Applied model	All
Wire diameter	11.5 (0.453)
Coil outer diameter	
Large diameter	123.5 - 126.5 (4.86 - 4.98)
Small diameter	112.3 - 115.3 (4.42 - 4.54)
Free length	350 (13.78)
Identification color	Red x 1

#### SHOCK ABSORBER

Applied model	All
Piston rod diameter	mm (in)
	12.5 (0.492)

#### DRIVE SHAFT

Joint type		
Final drive side		TS82F
Wheel side		TS82C
Grease name		
Final drive side		Nissan genuine grease or equivalent
Wheel side		Nissan genuine grease or equivalent
Specified amount of grease	g (oz)	
Final drive side		155 - 165 (5.47 - 5.82)
Wheel side		135 - 145 (4.76 - 5.11)
Boot length	mm (in)	
Final drive side (L <sub>1</sub> )		95 - 97 (3.74 - 3.82)
Wheel side (L <sub>2</sub> )		

Final drive side

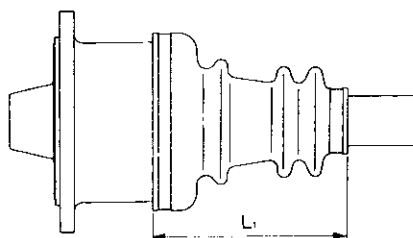

SRA133A

Wheel side

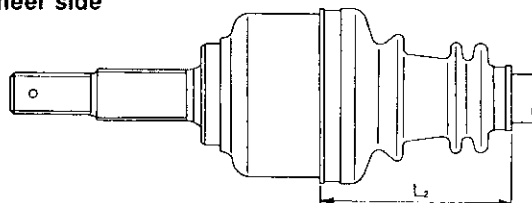

SRA543A

#### REAR STABILIZER BAR

Model	LHD	RHD
Stabilizer diameter mm (in)	17.3 (0.681)	18.0 (0.709)
Identification color	Light green	Orange

## SERVICE DATA AND SPECIFICATIONS (SDS)

### Inspection and Adjustment

#### WHEEL ALIGNMENT (Unladen\*1)

Applied model	Australia	Except Australia
Camber degree	-1°40' to -0°40'	-1°35' to -0°35'
Toe-in	0 - 5.0 (0 - 0.197)	
A - B mm (in)		
Total angle 2θ degree	0° - 28'	

\*1. Fuel, radiator coolant and engine oil full.  
Spare tire, jack, hand tools and mats in designated positions

#### LOWER BALL JOINT

Swing force (Measuring point: cotter pin hole of ball stud) N (kg, lb)	7.8 - 54.9 (0.8 - 5.6, 1.8 - 12.3)
Turning torque N·m (kg-cm, in-lb)	0.5 - 3.4 (5 - 35, 4.3 - 30.4)
Vertical end play mm (in)	0 (0)

#### WHEEL BEARING

Wheel bearing axial end play mm (in)	0.05 (0.0020) or less
Wheel bearing lock nut Tightening torque N·m (kg-m, ft-lb)	206 - 275 (21 - 28, 152 - 203)

#### WHEEL RUNOUT (Radial and lateral)

Wheel type	Radial runout	Lateral runout
Aluminum wheel mm (in)	0.3 (0.012) or less	
Steel wheel mm (in)	0.7 (0.028) or less	1.0 (0.039) or less

RA

# BRAKE SYSTEM

## SECTION **BR**

### CONTENTS

<b>PRECAUTIONS AND PREPARATION</b> .....	2	Assembly .....	15
Precautions .....	2	Inspection (On-vehicle) .....	15
Commercial Service Tools .....	2	<b>REAR DISC BRAKE</b> .....	16
<b>BRAKE HYDRAULIC LINE/CONTROL VALVE</b> .....	3	Pad Replacement .....	16
Brake Hydraulic Line .....	3	Removal .....	18
Proportioning Valve .....	4	Disassembly .....	18
<b>CHECK AND ADJUSTMENT</b> .....	5	Inspection — Caliper .....	19
Checking Brake Fluid Level .....	5	Inspection — Rotor .....	20
Checking Brake Line .....	5	Assembly .....	20
Changing Brake Fluid .....	5	Installation .....	21
Bleeding Brake System .....	5	<b>PARKING BRAKE CONTROL</b> .....	22
			22



## PRECAUTIONS AND PREPARATION

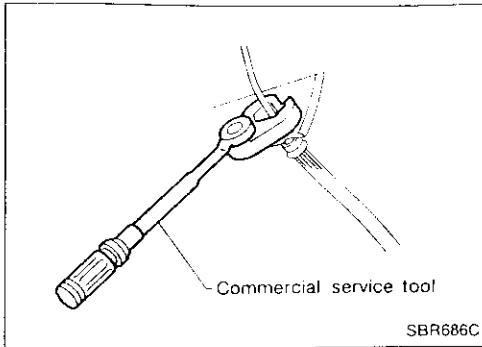

### Precautions

- Recommended brake fluid.  
For Europe: DOT3 or DOT4  
Except for Europe: DOT3  
For Europe, never mix different type brake fluids (DOT3 and DOT4).
- Never reuse drained brake fluid.
- Be careful not to splash brake fluid on painted areas.
- To clean or wash all parts of master cylinder, disc brake caliper and wheel cylinder, use clean brake fluid.
- Never use mineral oils such as gasoline or kerosene. They will ruin rubber parts of the hydraulic system.
- Use flare nut wrench when removing and installing brake tube.
- Always torque brake lines when installing.

### WARNING:

- Clean brake pads and shoes with a waste cloth, then wipe with a dust collector.

### Commercial Service Tools

Tool name	Description
<ul style="list-style-type: none"> <li>① Flare nut crows foot</li> <li>② Torque wrench</li> </ul>	<div style="text-align: right;">Removing and installing each brake piping</div> <p>NT360</p> <p>a: 10 mm (0.39 in)</p>
Brake fluid pressure gauge	<div style="text-align: right;">Measuring brake fluid pressure</div> <p>NT151</p>

# BRAKE HYDRAULIC LINE/CONTROL VALVE

## Brake Hydraulic Line

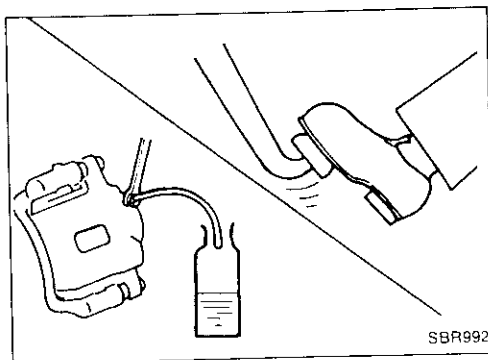
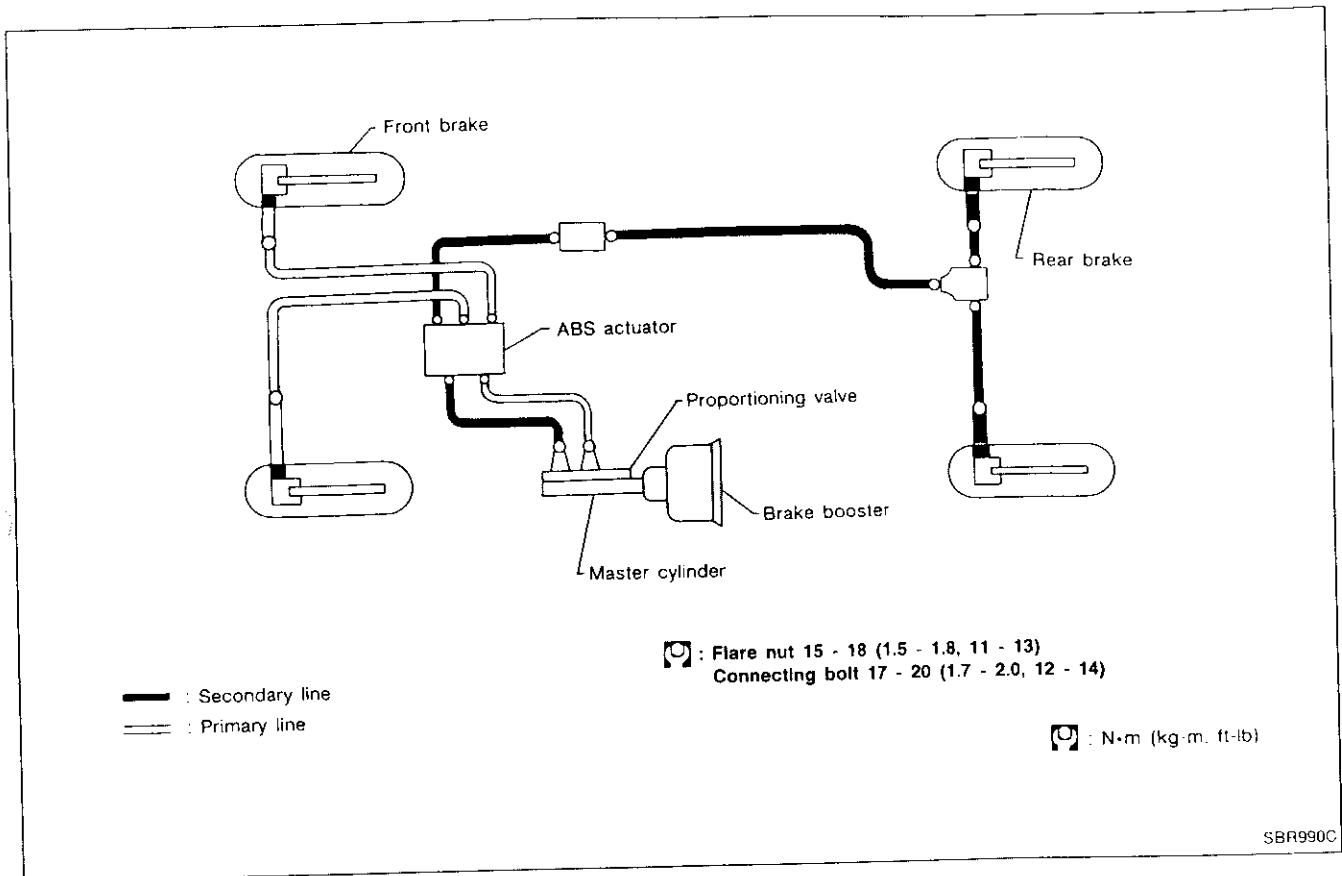

### REMOVAL

#### CAUTION:

- Be careful not to splash brake fluid on painted areas; it may cause paint damage. If brake fluid is splashed on painted areas, wash it away with water immediately.
  - All hoses must be free from excessive bending, twisting and pulling.
1. Connect vinyl tube to air bleeder valve.
  2. Drain brake fluid from each air bleeder valve by depressing brake pedal.
  3. Remove flare nut connecting brake tube and hose, then withdraw lock spring.
  4. Cover openings to prevent entrance of dirt whenever disconnecting brake line.

### INSPECTION

Check brake lines (tubes and hoses) for cracks, deterioration or other damage. Replace any damaged parts.

## BRAKE HYDRAULIC LINE/CONTROL VALVE

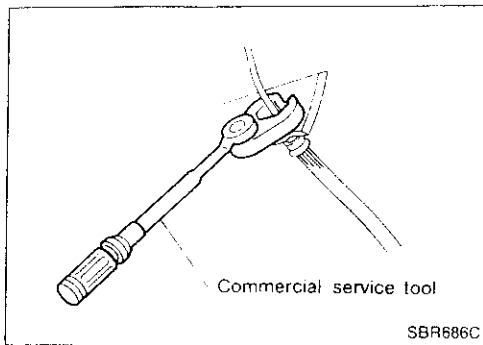

### INSTALLATION

#### CAUTION:

- Refill with new brake fluid.  
For Europe: DOT3 or DOT4  
Except for Europe: DOT3  
For Europe, never mix different type brake fluids (DOT3 and DOT4).
  - Never reuse drained brake fluid.
1. Tighten all flare nuts and connecting bolts.

#### Specification:

##### Flare nut

15 - 18 N·m (1.5 - 1.8 kg·m, 11 - 13 ft·lb)

##### Connecting bolt

17 - 20 N·m (1.7 - 2.0 kg·m, 12 - 14 ft·lb)

2. Refill until new brake fluid comes out of each air bleeder valve.
3. Bleed air. Refer to "Bleeding Brake System" (BR-5).

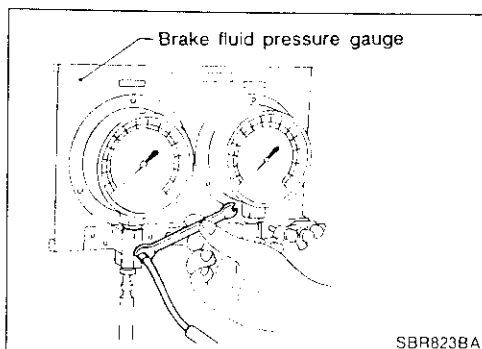
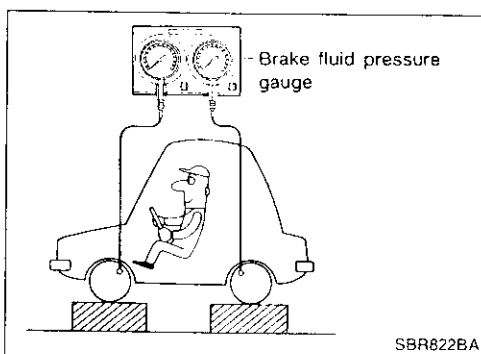

### Proportioning Valve

#### INSPECTION

#### CAUTION:

- Carefully monitor brake fluid level at master cylinder.
  - Use new brake fluid.  
For Europe: DOT3 or DT4  
Except for Europe: DOT3  
For Europe, never mix different type brake fluids (DOT3 and DOT4).
  - Be careful not to splash brake fluid on painted areas; it may cause paint damage. If brake fluid is splashed on paint areas, wash it away with water immediately.
1. Connect Tool to air bleeders of front and rear brakes on either LH and RH side.
  2. Bleed air from the Tool.
  3. Check fluid pressure by depressing brake pedal.

Unit: kPa (bar, kg/cm<sup>2</sup>, psi)

Applied pressure (Front brake)	7,355 (73.6, 75, 1,067)
Output pressure (Rear brake)	5,100 - 5,492 (51.0 - 54.9, 52 - 56, 739 - 796)

4. Bleed air after disconnecting the Tool. Refer to "Bleeding Brake System" (BR-5).

## CHECK AND ADJUSTMENT

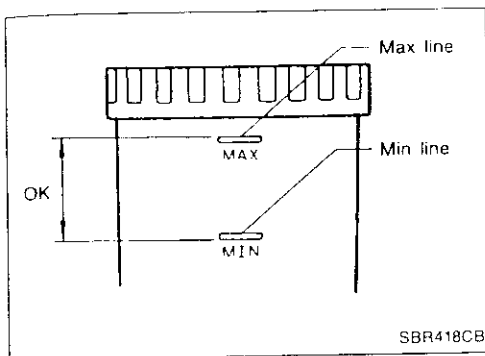

### Checking Brake Fluid Level

- Check fluid level in reservoir tank. It should be between Max and Min lines on reservoir tank.
- If fluid level is extremely low, check brake system for leaks.
- If brake warning lamp comes on, check brake fluid level switch and parking brake switch.

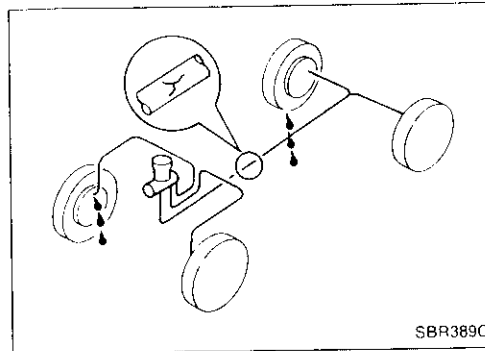

### Checking Brake Line

#### CAUTION:

If leakage occurs around joints, retighten or, if necessary, replace damaged parts.

1. Check brake lines (tubes and hoses) for cracks, deterioration or other damage. Replace any damaged parts.
2. Check for oil leakage by fully depressing brake pedal while engine is running.

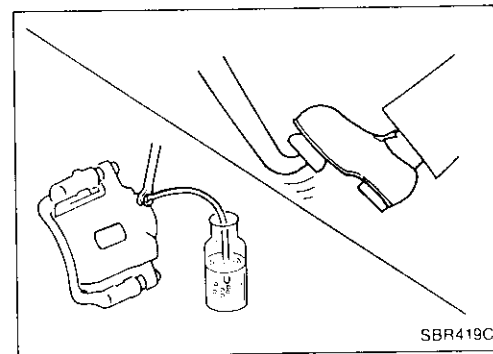

### Changing Brake Fluid

#### CAUTION:

- Refill with new brake fluid.  
For Europe: DOT3 or DOT4/Except for Europe: DOT3  
For Europe, never mix different type brake fluids (DOT3 and DOT4).
  - Always keep fluid level higher than minimum line on reservoir tank.
  - Never reuse drained brake fluid.
  - Be careful not to splash brake fluid on painted areas; it may cause paint damage. If brake fluid is splashed on painted areas, wash it away with water immediately.
1. Clean inside of reservoir tank, and refill with new brake fluid.
  2. Connect a vinyl tube to each air bleeder valve.
  3. Drain brake fluid from each air bleeder valve by depressing brake pedal.
  4. Refill until brake fluid comes out of each air bleeder valve. Use same procedure as in bleeding hydraulic system to refill brake fluid. Refer to "Bleeding Brake System" (BR-5).

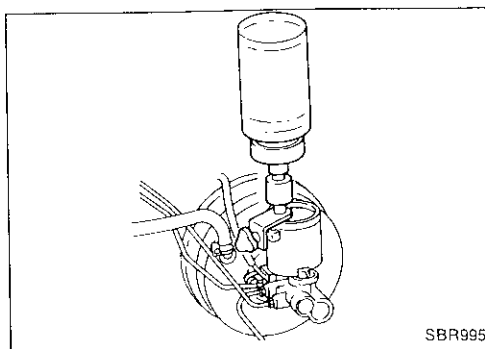

### Bleeding Brake System

#### CAUTION:

- Carefully monitor brake fluid level at master cylinder during bleeding operation.
- Fill reservoir with new brake fluid.  
For Europe: DOT3 or DOT4/Except for Europe: DOT3  
For Europe, never mix different type brake fluids (DOT3 and DOT4).  
Make sure it is full at all times while bleeding air out of system.



## CHECK AND ADJUSTMENT

### Bleeding Brake System (Cont'd)

- Place a container under master cylinder to avoid spillage of brake fluid.
- Turn ignition switch OFF and disconnect ABS actuator connectors or battery ground cable.

● Bleed air in the following order:

# BRAKE PEDAL AND BRACKET

## Removal and Installation

SEC. 465

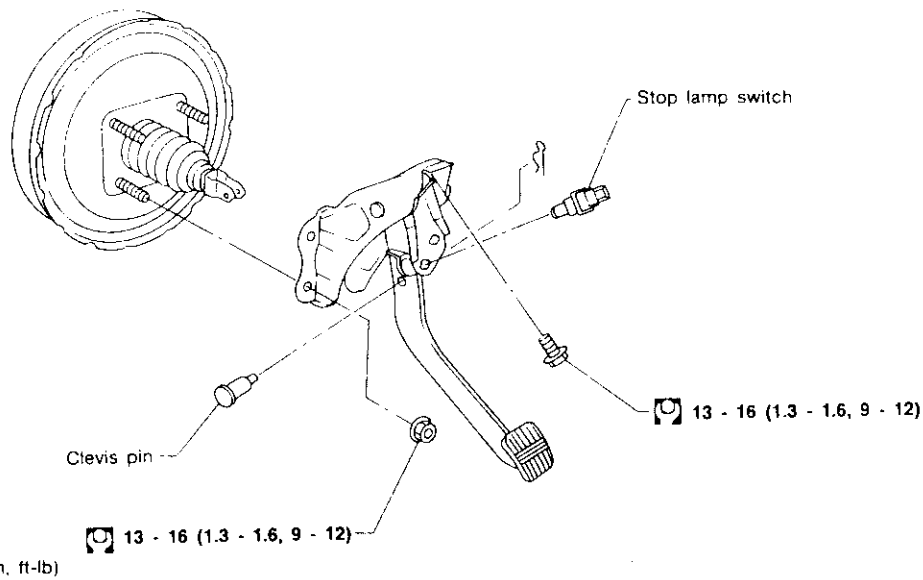

⊗ : N·m (kg-m, ft-lb)

SBR565CC

### Inspection

Check brake pedal for following items.

- Brake pedal bend
- Clevis pin deformation
- Crack of any welded portion

### Adjustment

Check brake pedal free height from dash reinforcement panel. Adjust if necessary.

- H: Free height**  
Refer to SDS (BR-66).
- D: Depressed height**  
Refer to SDS. (BR-66).  
Under force of 490 N (50 kg, 110 lb) with engine running
- C<sub>1</sub>, C<sub>2</sub>: Clearance between pedal stopper and threaded end of stop lamp switch and ASCD switch**  
0.3 - 1.0 mm (0.012 - 0.039 in)

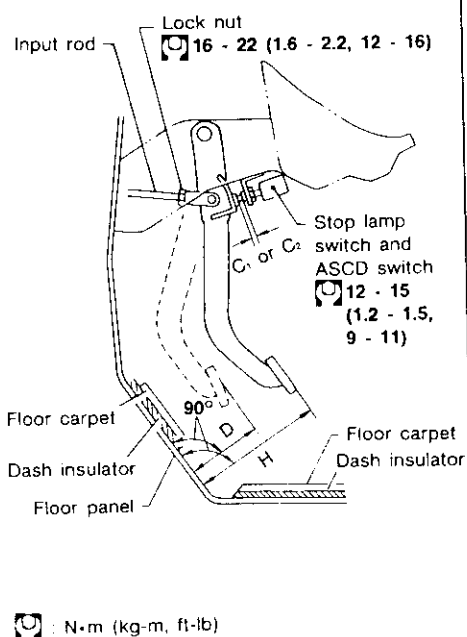

⊗ : N·m (kg-m, ft-lb)

SBR071D

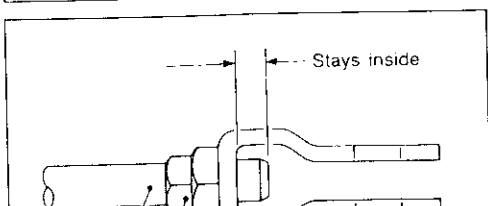

1. Loosen lock nut and adjust pedal free height by turning brake booster input rod. Then tighten lock nut.
2. Check pedal free play.
3. Check brake pedal's depressed height while engine is running. If lower than specification, check for leaks, air in system or damage to components (master cylinder, wheel

BR

## MASTER CYLINDER

### Disassembly (Cont'd)

2. Remove valve stopper while piston is pushed into cylinder.
3. Remove piston assemblies.

If it is difficult to remove secondary piston assembly, gradually apply compressed air through fluid outlet.

4. Draw out reservoir tank.

### Inspection

Check for the following items.

**Replace any part if damaged.**

**Master cylinder:**

- Pin holes or scratches on inner wall.

**Piston:**

- Deformation of or scratches on piston cups.

### Assembly

1. Insert secondary piston assembly. Then insert primary piston assembly.

- Pay attention to alignment of secondary piston slit with valve stopper mounting hole of cylinder body.

2. Install stopper cap.

**Before installing stopper cap, ensure that claws are bent inward.**

3. Push reservoir tank seals.

4. Push reservoir tank into master cylinder.

5. Install valve stopper while piston is pushed into cylinder.

### Installation

**CAUTION:**

- Refill with new brake fluid.

**For Europe: DOT3 or DOT4/Except for Europe: DOT3**

**For Europe, never mix different type brake fluids (DOT3 and DOT4).**

- Never reuse drained brake fluid.

1. Place master cylinder onto brake booster and secure mounting nuts lightly.

2. Torque mounting nuts.

**12 - 15 N·m (1.2 - 1.5 kg-m, 9 - 11 ft-lb)**

3. Fill up reservoir tank with new brake fluid.

4. Plug all ports on master cylinder with fingers to prevent air suction while releasing brake pedal.

5. Have driver depress brake pedal slowly several times until no air comes out of master cylinder.

6. Fit brake lines to master cylinder.

7. Tighten flare nuts.

**⌚: 15 - 18 N·m (1.5 - 1.8 kg-m, 11 - 13 ft-lb)**

8. Bleed air from brake system. Refer to "Bleeding Brake System" (BR-5).

SBR231C

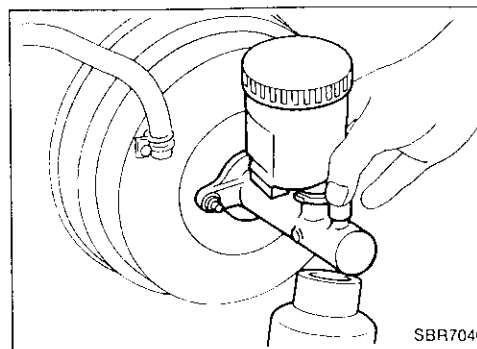
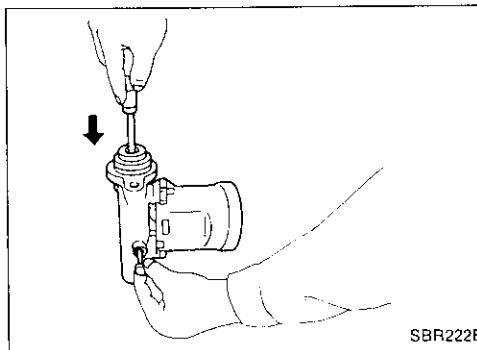
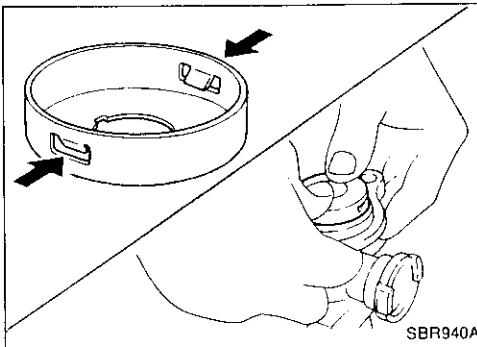
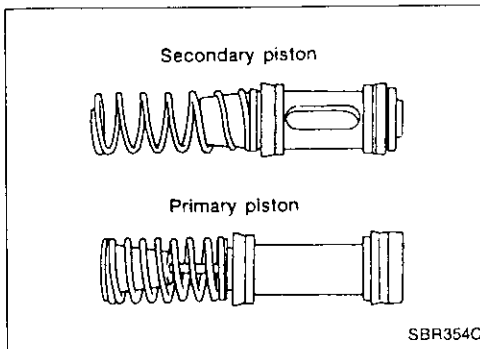

BR

# MASTER CYLINDER

SEC. 460

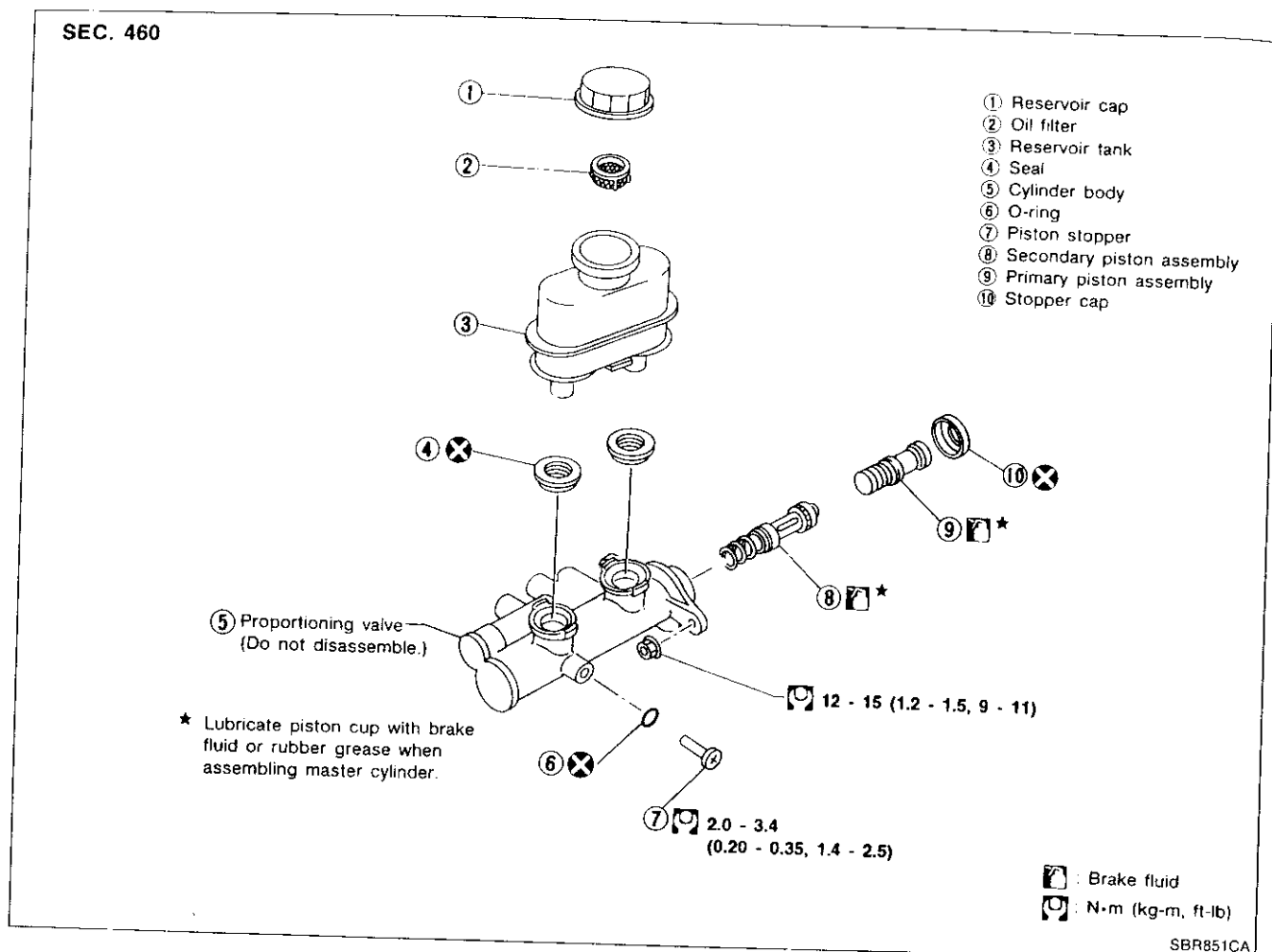

## Removal

### CAUTION:

Be careful not to splash brake fluid on painted areas; it may cause paint damage. If brake fluid is splashed on painted areas, wash it away with water immediately.

1. Connect a vinyl tube to air bleeder valve.
2. Drain brake fluid from each air bleeder valve, depressing brake pedal to empty fluid from master cylinder.
3. Remove brake pipe flare nuts.
4. Remove master cylinder mounting nuts.

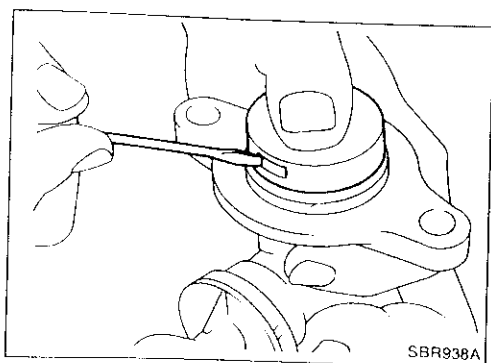

## Disassembly

1. Bend claws of stopper cap outward.

## BRAKE BOOSTER/VACUUM HOSE

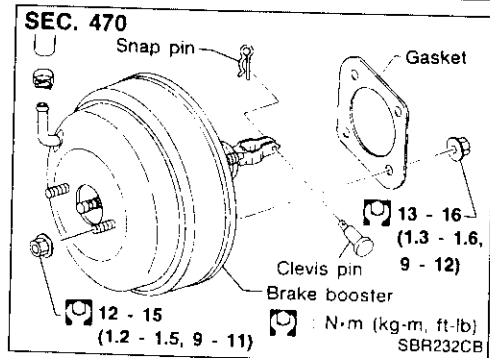
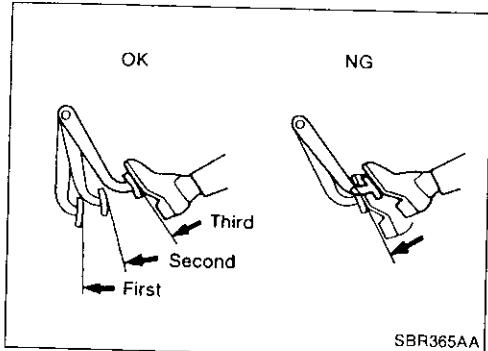
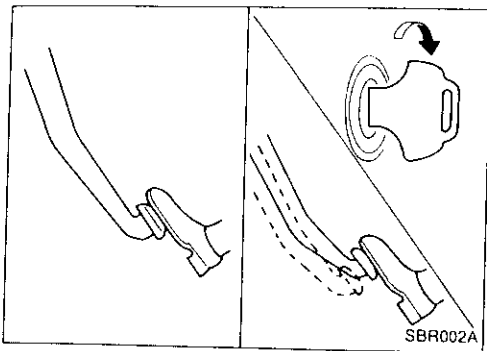

### Brake Booster

#### ON-VEHICLE SERVICE

##### Operating check

- Stop engine and depress brake pedal several times. Check that pedal stroke does not change.
- Depress brake pedal, then start engine. If pedal goes down slightly, operation is normal.

##### Airtight check

- Start engine, and stop it after one or two minutes. Depress brake pedal several times slowly. The pedal should go further down the first time, and then it should gradually rise thereafter.
- Depress brake pedal while engine is running, and stop engine with pedal depressed. The pedal stroke should not change after holding pedal down for **30 seconds**.

#### REMOVAL

##### CAUTION:

- Be careful not to splash brake fluid on painted areas; it may cause paint damage. If brake fluid is splashed on painted areas, wash it away with water immediately.
- Be careful not to deform or bend brake pipes, during removal of booster.

#### INSPECTION

## BRAKE BOOSTER/VACUUM HOSE

### Brake Booster (Cont'd)

thread when installing. Due to the angle of installation, threads can be damaged by the dash panel.

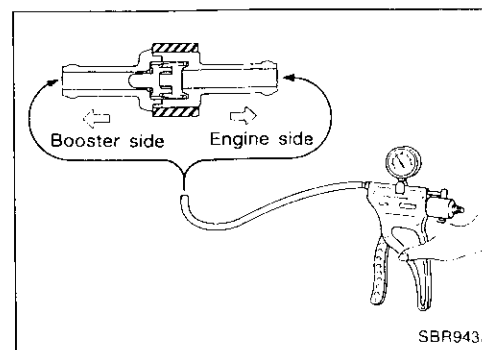
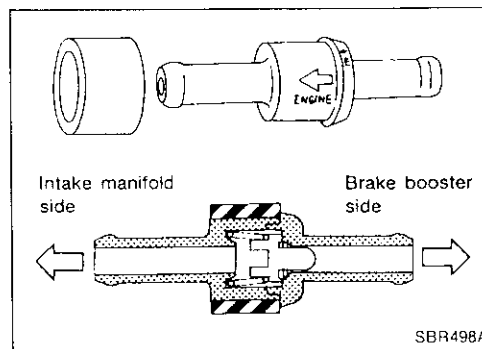
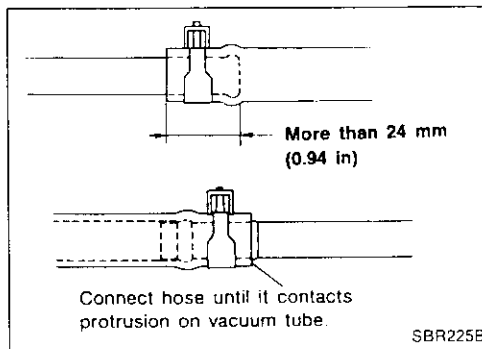
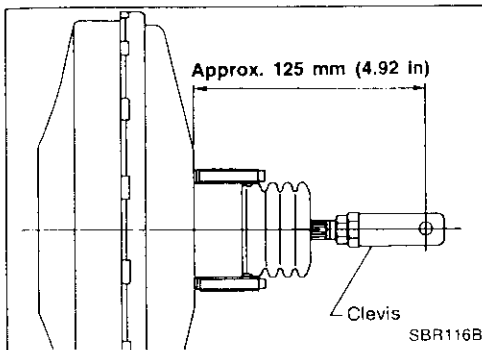

1. Before fitting booster, temporarily adjust clevis to dimension shown.
2. Fit booster, then secure mounting nuts (brake pedal bracket to booster) lightly.
3. Connect brake pedal and booster input rod with clevis pin.
4. Secure mounting nuts.
  - Specification: 13 - 16 N·m (1.3 - 1.6 kg-m, 9 - 12 ft-lb)**
5. Install master cylinder. Refer to "Installation" in "MASTER CYLINDER" (BR-9).
6. Bleed air. Refer to "Bleeding Brake System" (BR-5).

### Vacuum Hose

#### REMOVAL AND INSTALLATION

##### CAUTION:

When installing vacuum hoses, pay attention to the following points.

- Do not apply any oil or lubricants to vacuum hose and check valve.
- Insert vacuum tube into vacuum hose as shown.
- Install check valve, paying attention to its direction.

#### INSPECTION

##### Hoses and connectors

Check vacuum lines, connections and check valve for airtightness, improper attachment chafing and deterioration.

##### Check valve

Check vacuum with a vacuum pump.

Connect to booster side	Vacuum should exist.
Connect to engine side	Vacuum should not exist.

## FRONT DISC BRAKE (OPF25V)

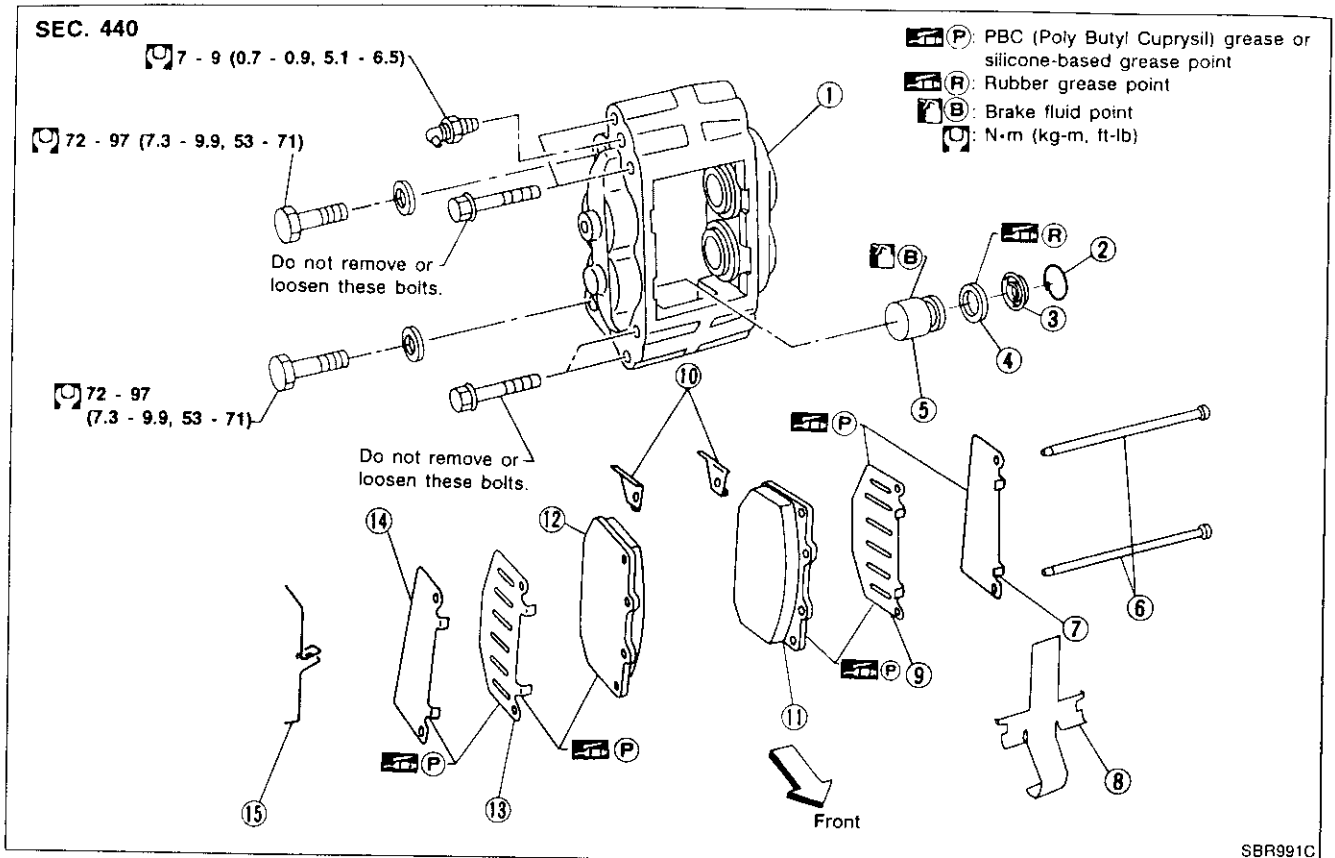

SBR991C

- |                  |                |                |
|------------------|----------------|----------------|
| ① Caliper        | ⑥ Pad pin      | ⑪ Outer pad    |
| ② Retaining ring | ⑦ Outer shim A | ⑫ Inner pad    |
| ③ Dust seal      | ⑧ Cross spring | ⑬ Inner shim B |
| ④ Piston seal    | ⑨ Outer shim B | ⑭ Inner shim A |
| ⑤ Piston         | ⑩ Pad retainer | ⑮ Clip         |

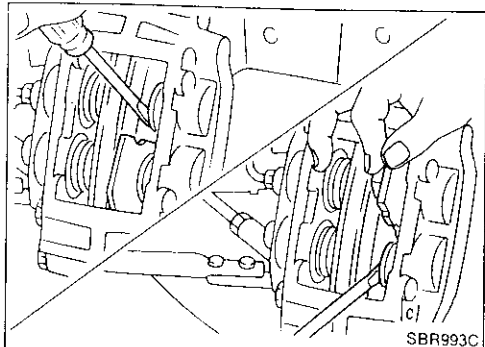
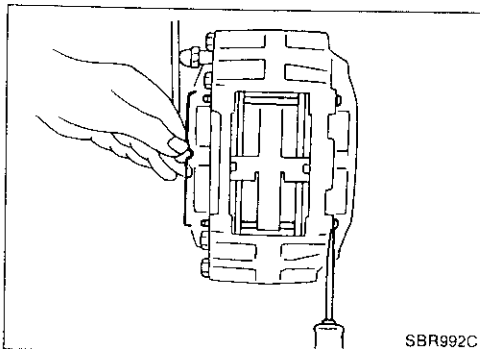

### Pad Replacement

#### CAUTION:

- When pads are removed, do not depress brake pedal because piston will pop out.
- Be careful not to damage dust seal or get oil on rotor. Always replace shims when replacing pads.

1. Remove clip from pad pin and then remove pad pin.
2. Remove cross spring.
  
3. Pull out outer pad and insert it temporarily between lower piston and rotor as shown.
4. Push back upper piston with a suitable tool and insert new pad so it contacts upper piston as shown.
5. Pull out old pad.
6. Push back lower piston with a suitable tool.
7. Pull out new pad and reinstall it in the proper position.
8. Repeat step 3 to 7 for inner pad.
9. Install cross spring, pad pin and clip.

## FRONT DISC BRAKE (OPF25V)

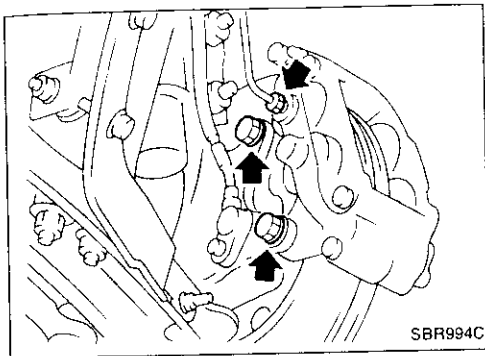

### Removal and Installation

1. Disconnect brake tube.
2. Remove brake pad.
3. Remove brake caliper mounting bolts.

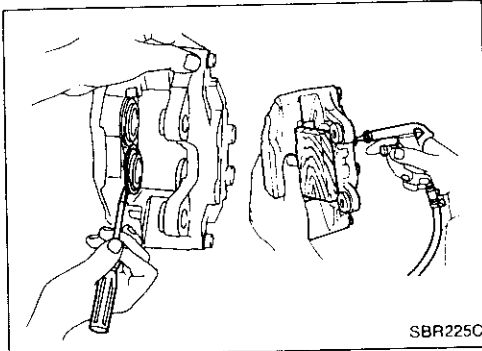

### Disassembly

1. Remove retaining ring.
2. Push out piston with dust seal using compressed air.

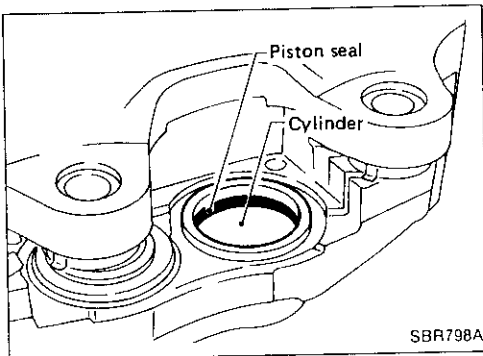

3. Remove piston seal.

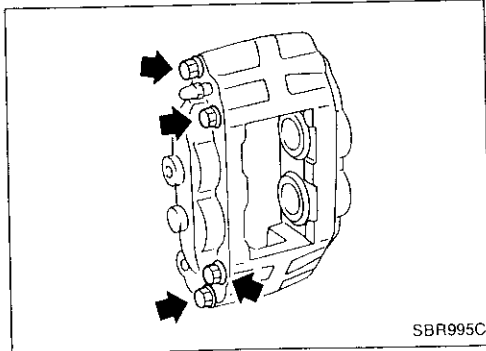

### CAUTION:

Be careful not to loosen or remove bolts joining both sides of caliper.

If there is any fluid leakage, replace caliper assembly.

BR



## FRONT DISC BRAKE (OPF25V)

### Inspection

#### CALIPER

- Check dust seals for damage.
- Check calipers for damage, rust or foreign materials.
- Check inside surface of cylinder for scoring, rust, wear, damage or foreign materials. Replace if any such condition exists.
- Eliminate minor damage from rust or foreign materials by polishing surface with fine emery paper.

#### CAUTION:

Use brake fluid to clean.

#### PISTON

Check piston for scoring, rust, wear, damage or foreign materials. Replace if any condition exists.

#### CAUTION:

Piston sliding surface is plated. Do not polish with emery paper even if rust or foreign materials are stuck to sliding surface.

#### PAD PIN AND CLIPS

Check for wear, cracks deformation, deterioration, rust or other damage. Replace if any such condition exists.

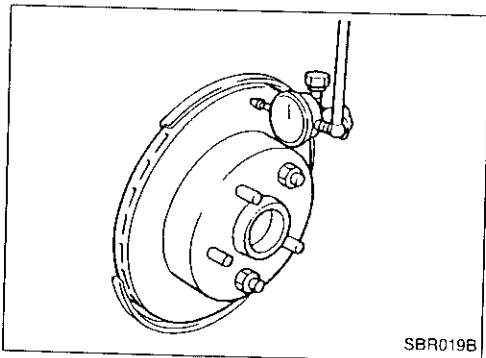

#### RUNOUT

1. Secure rotor to wheel hub with at least two nuts (M12 x 1.25).
2. Check runout using a dial indicator.

Make sure that wheel bearing axial end play is within the specifications before measuring. Refer to "Front Wheel Bearing" in FA section.

#### Maximum runout:

0.05 mm (0.0020 in)

3. If the runout is out of specification, find minimum runout position as follows:
  - a. Remove nuts and rotor from wheel hub.
  - b. Shift the rotor one hole and secure rotor to wheel hub with nuts.
  - c. Measure runout.
  - d. Repeat steps a. to c. so that minimum runout position can be found.
4. If the runout is still out of specification, turn rotor with on-car brake lathe ("MAD, DL-8700", "AMMCO 700 and 705" or equivalent).

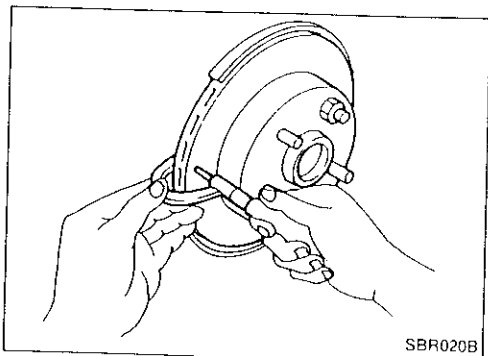

#### THICKNESS

Thickness variation (At least 8 positions):

Maximum 0.01 mm (0.0004 in)

If thickness variation exceeds the specification, turn rotor with on-car brake lathe.

Rotor repair limit:

28.0 mm (1.102 in)

## FRONT DISC BRAKE (OPF25V)

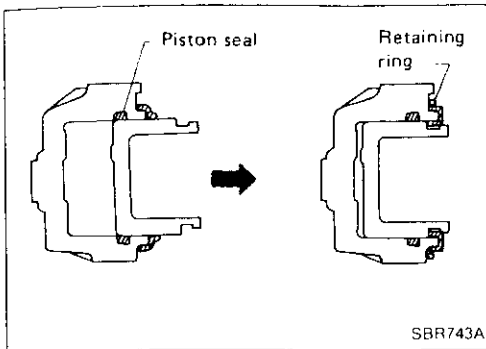

### Assembly

1. Insert piston seal into groove on cylinder body.
2. With dust seal fitted to piston, install piston into cylinder body.
3. Secure dust seal properly.
4. Install retaining ring.

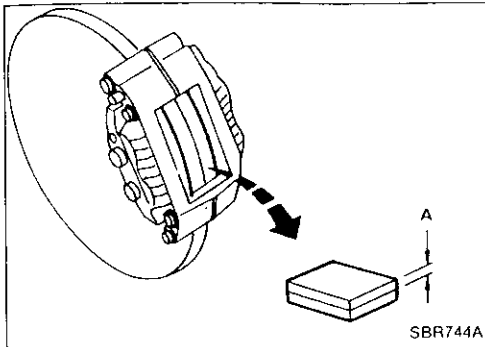

### Inspection (On-vehicle)

#### DISC PAD

- Check pad shims for deformation or damage.
- Check disc pad for wear or damage.

**Pad standard thickness (A):**

10.0 mm (0.394 in)

**Pad wear limit (A):**

2.0 mm (0.079 in)

REAR DISC BRAKE



Pad Replacement

# REAR DISC BRAKE

SEC. 441

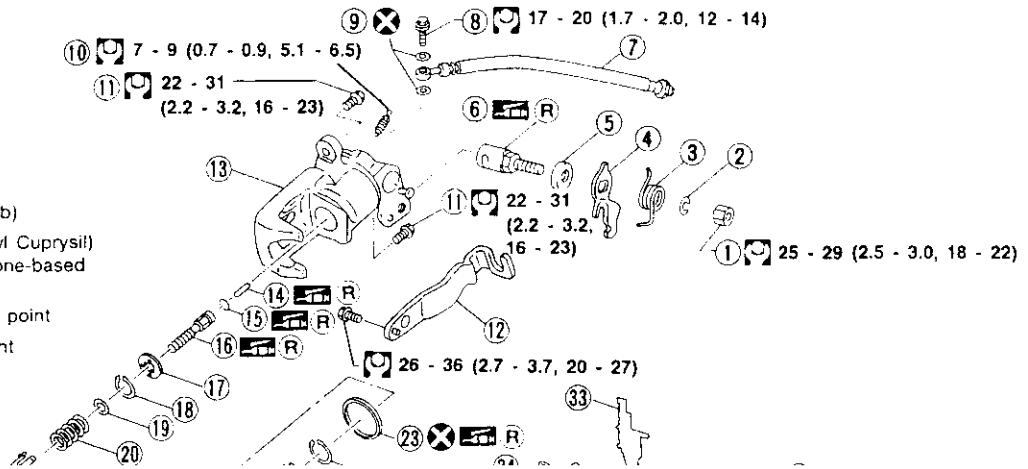

## REAR DISC BRAKE

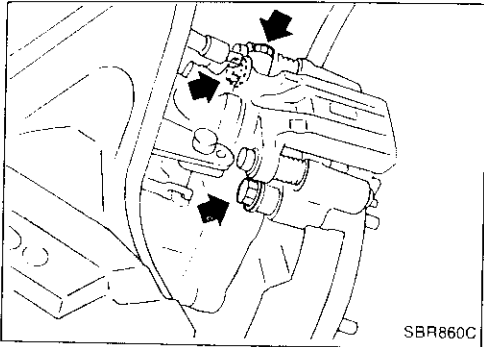

### Removal

#### WARNING:

Clean brake pads with a vacuum dust collector to minimize the hazard of airborne particles or other materials.

1. Remove brake cable mounting bracket bolt and lock spring.
2. Remove torque member fixing bolts and connecting bolt. **It is not necessary to remove connecting bolt except for disassembly or replacement of caliper assembly. In this case, suspend caliper assembly with wire so as not to stretch brake hose.**

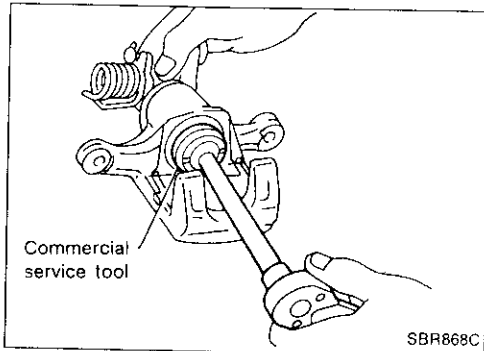

### Disassembly

1. Remove piston by turning it counterclockwise with suitable commercial service tool or long nose pliers.

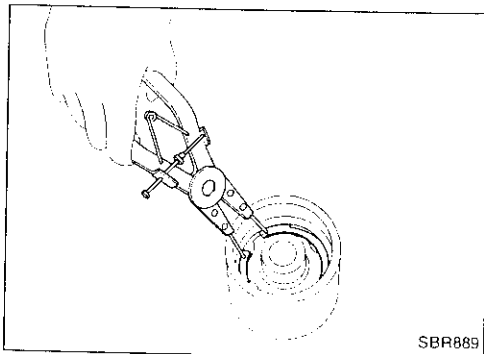
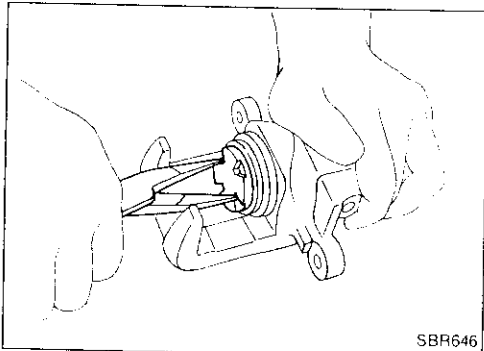

2. Pry off ring A from piston with suitable pliers and remove adjusting nut.

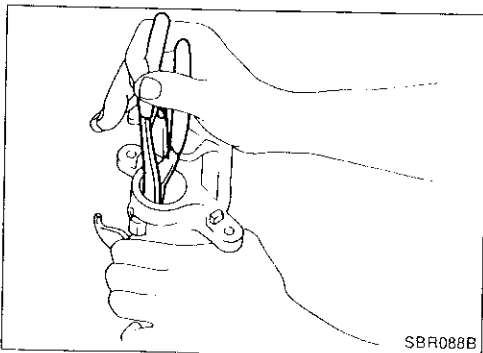

3. Disassemble cylinder body.
  - a. Pry off ring B with suitable pliers, then remove spring cover, spring and seat.
  - b. Pry off ring C, then remove key plate, push rod and strut.

## REAR DISC BRAKE

### Disassembly (Cont'd)

- c. Remove piston seal.  
**Be careful not to damage cylinder body.**

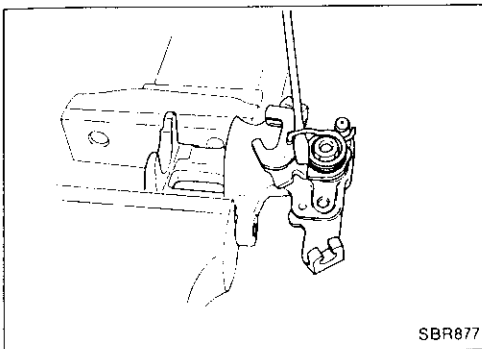
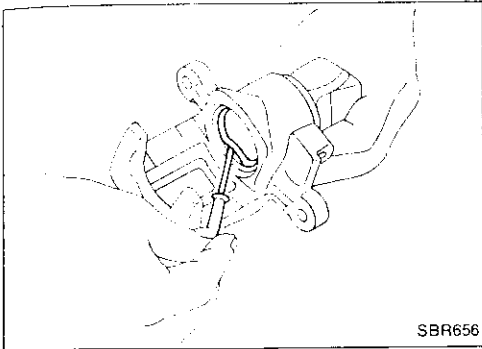

4. Remove return spring, nut and parking brake lever.

### Inspection — Caliper

#### CAUTION:

Use brake fluid to clean cylinder. Never use mineral oil.

#### CYLINDER BODY

- Check inside surface of cylinder for score, rust, wear, damage or presence of foreign materials. If any of the above conditions are observed, replace cylinder body.
- Minor damage from rust or foreign materials may be eliminated by polishing surface with a fine emery paper. Replace cylinder body if necessary.

#### TORQUE MEMBER

Check for wear, cracks or other damage. Replace if necessary.

#### PISTON

##### CAUTION:

**Piston sliding surface is plated. Do not polish with emery paper even if rust or foreign matter is stuck to sliding surface.** Check piston for score, rust, wear, damage or presence of foreign materials.

Replace if any of the above conditions are observed.

#### PIN AND PIN BOOT

Check for wear, cracks or other damage.

Replace if any of the above conditions are observed.

## REAR DISC BRAKE

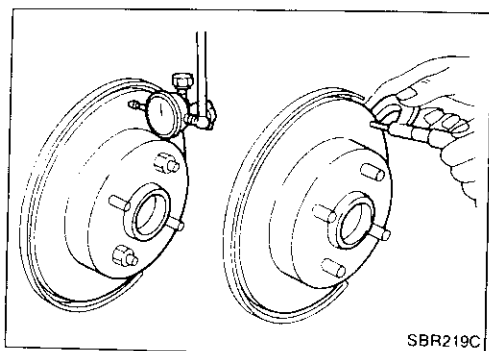

### Inspection — Rotor

#### RUBBING SURFACE

Check rotor for roughness, cracks or chips.

#### RUNOUT

1. Secure rotor to wheel hub with two nuts (M12 x 1.25).
2. Check runout using a dial indicator.

**Make sure that axial end play is within the specifications before measuring. Refer to "Rear Wheel Bearing" in RA section.**

3. Change relative positions of rotor and wheel hub so that runout is minimized.

**Maximum runout:**

**0.07 mm (0.0028 in)**

#### THICKNESS

**Rotor repair limit:**

**Standard thickness**

**9 mm (0.35 in)**

**Minimum thickness**

**8 mm (0.31 in)**

**Thickness variation (At least 8 portions)**

**Maximum 0.02 mm (0.0008 in)**

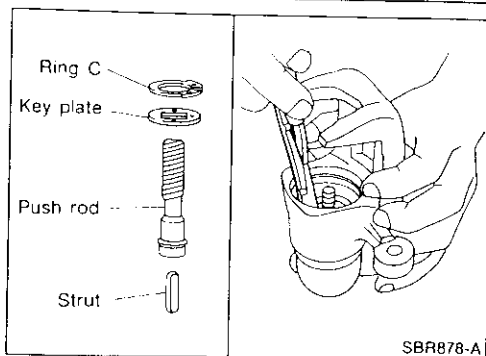
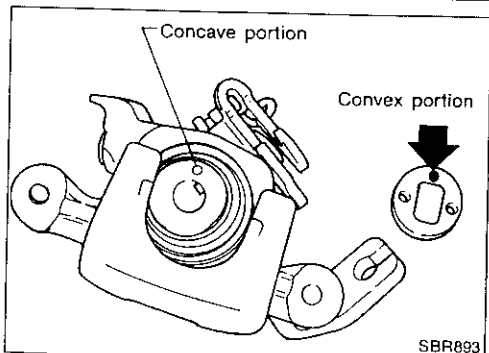
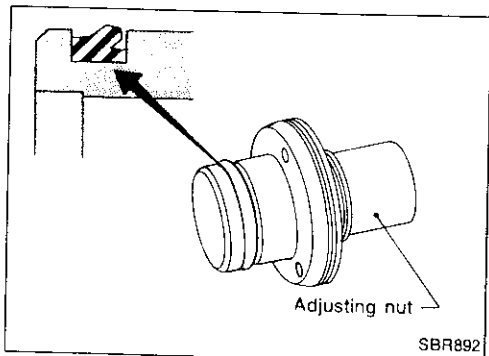

### Assembly

1. Install cup in the specified direction.

2. Fit push rod into square hole in key plate. Also match convex portion of key plate with concave portion of cylinder.

3. Install ring C with a suitable tool.

## REAR DISC BRAKE

### Assembly (Cont'd)

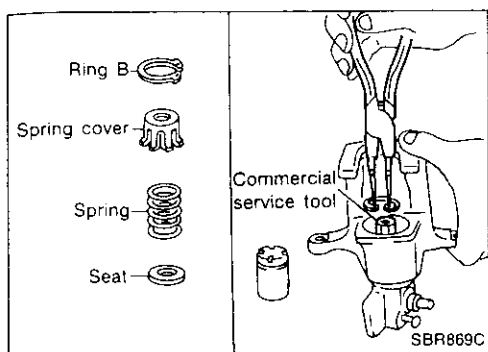

4. Install seat, spring, spring cover and ring B while depressing with suitable commercial service tool or press and drift.

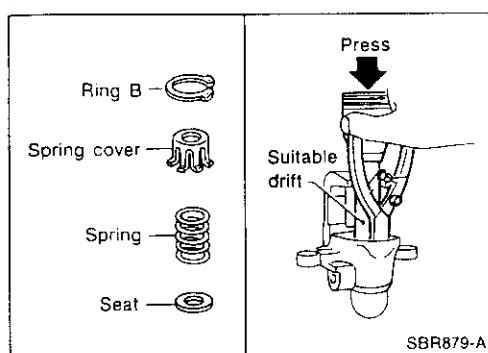

5. Install cup, adjuster, bearing, spacers, washers and ring A with a suitable tool.

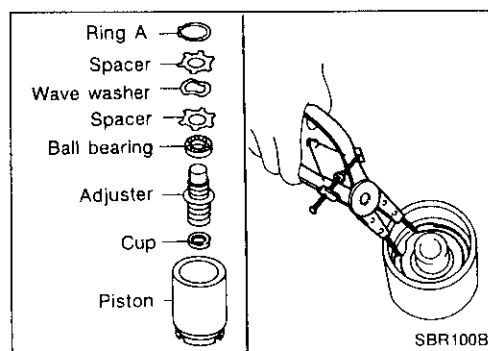

6. Fit parking brake lever and tighten nut.  
7. Fit return spring in the order shown.

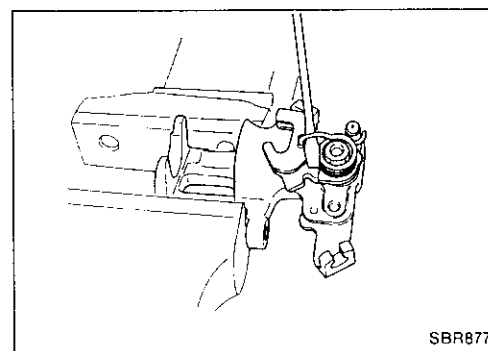

### Installation

#### CAUTION:

- Refill with new brake fluid "DOT 3" (Except for Europe) and "DOT3 or DOT4" (For Europe). For Europe, never mix different type brake fluids (DOT3 and DOT4).
  - Never reuse drained brake fluid.
1. Install brake hose to caliper securely.
  2. Install all parts and secure all bolts.
  3. Bleed air. Refer to "Bleeding Brake System" (BR-5).



## PARKING BRAKE CONTROL

SEC. 443

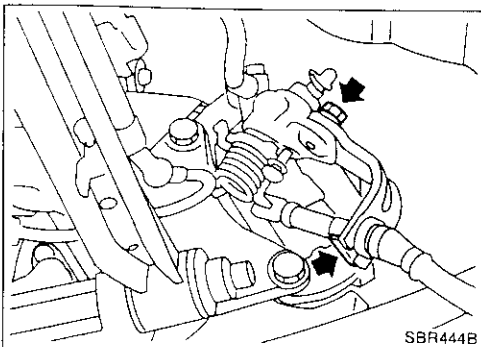
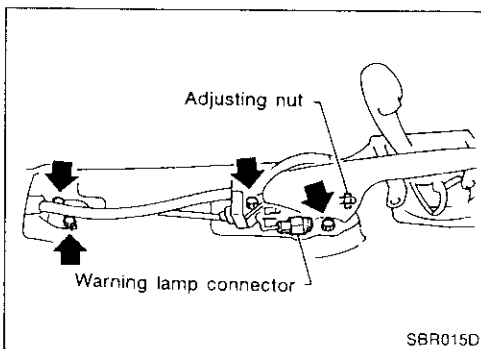
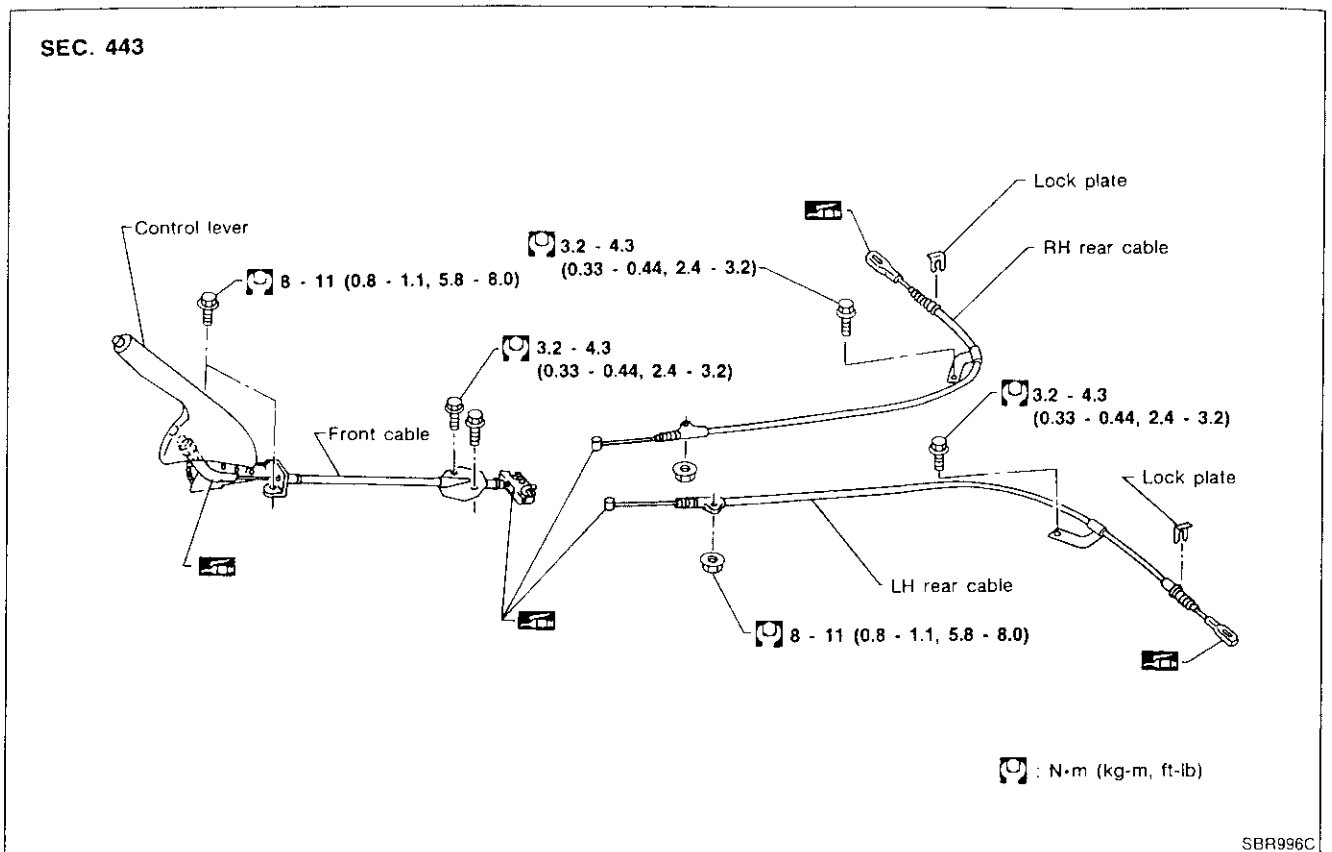

### Removal and Installation

1. To remove parking brake cable, first remove center console.
2. Disconnect warning lamp connector.
3. Remove bolts, slacken off and remove adjusting nut.
4. Remove lock plate, then disconnect cable from caliper.

## PARKING BRAKE CONTROL

### Removal and Installation (Cont'd)

- When installing parking brake cable at rear caliper, make sure to align matchmark on cable guide.

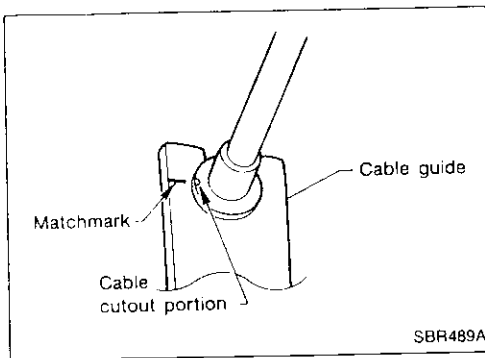

### Inspection

1. Check control lever for wear or other damage. Replace if necessary.
2. Check wires for discontinuity or deterioration. Replace if necessary.
3. Check warning lamp and switch. Replace if necessary.
4. Check parts at each connecting portion and, if found deformed or damaged, replace.

### Adjustment

Pay attention to the following points after adjustment.

- There is no drag when control lever is being released.
- Parking brake lever returns to stopper bolt when control lever for rear disc brake is released.

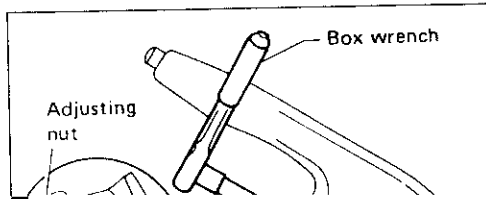
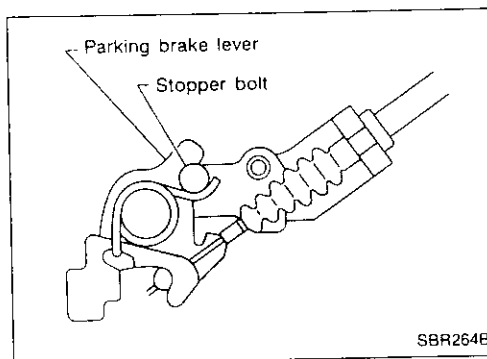

1. Pull control lever up by 4 or 5 notches.
2. Insert a box wrench into opening in control lever and loosen self-lock adjusting nut to slacken cables.
3. Completely push control lever down.
4. Forcefully depress brake pedal about five times (so that caliper is automatically set in position.).
5. Pull lever up by 4 or 5 notches.

BR

ST

# ANTI-LOCK BRAKE SYSTEM

## Purpose

The Anti-Lock Brake System (ABS) consists of electronic and hydraulic components. It allows for control of braking force so that locking of the wheels can be avoided.

The ABS:

- 1) Improves proper tracking performance through steering wheel operation.
- 2) Eases obstacle avoidance through steering wheel operation.
- 3) Improves vehicle stability.

## Operation

- The ABS will not operate at speeds below 5 to 10 km/h (3 to 6 MPH) to completely stop the vehicle. (The speeds will vary according to road conditions.)
- The ABS has self-test capabilities. A mechanical noise may be heard as the ABS performs a self-test the first time the vehicle reaches 10 km/h (6 MPH). This is a normal part of the self-test feature. If a malfunction is found during this check, the anti-lock warning lamp will come on.
- During ABS operation, a mechanical noise may be heard. This is a normal condition.

## ABS Hydraulic Circuit

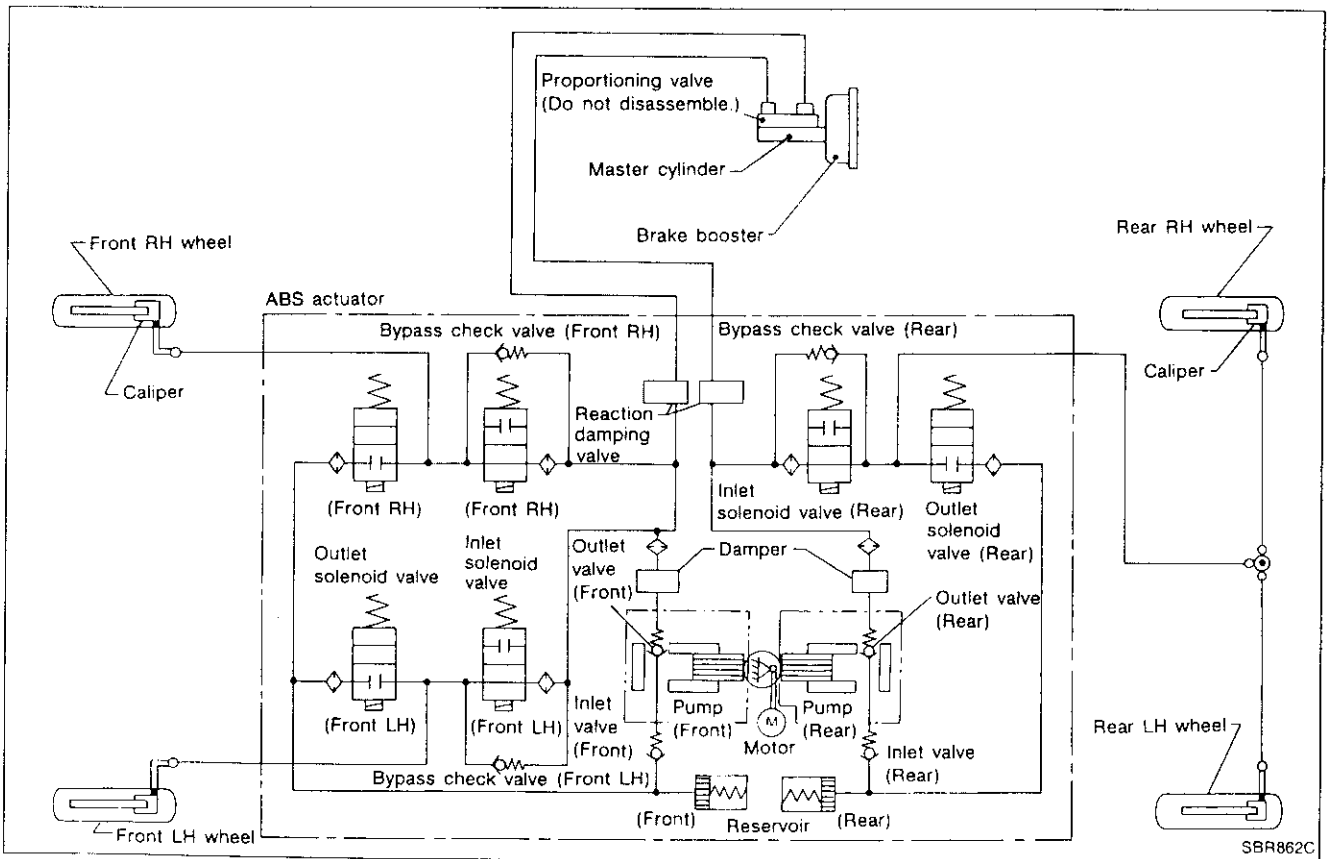

# ANTI-LOCK BRAKE SYSTEM

## System Components

ABS consists of:

- Wheel sensors (3)
- Actuator
- Control unit

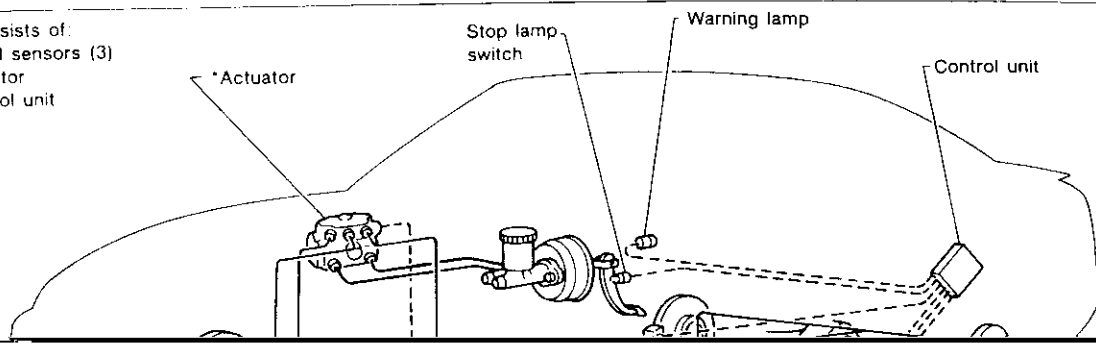

## ANTI-LOCK BRAKE SYSTEM

### System Description (Cont'd)

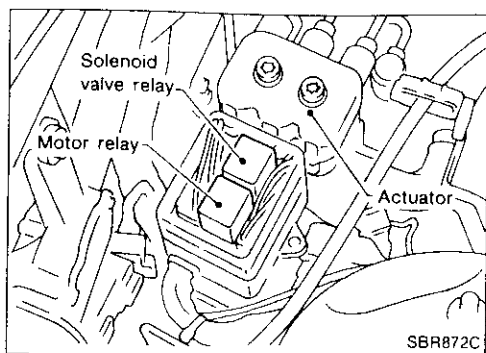

#### ACTUATOR

The actuator contains:

- An electric motor and pump
- Two relays
- Six solenoid valves, each inlet and outlet for
  - LH front
  - RH front
  - LH and RH rear

These components control the hydraulic circuit. The ABS control unit directs the actuator to increase, hold or decrease hydraulic pressure to all or individual wheels.

#### ABS actuator operation

		Inlet solenoid valve	Outlet solenoid valve	
Normal brake operation		OFF (Open)	OFF (Closed)	Master cylinder brake fluid pressure is directly transmitted to caliper via the inlet solenoid valve.
ABS operation	Pressure hold	ON (Closed)	OFF (Closed)	Hydraulic circuit is shut off to hold the caliper brake fluid pressure.
	Pressure decrease	ON (Closed)	ON (Open)	Caliper brake fluid is sent to reservoir via the outlet solenoid valve. Then it is pushed up to the master cylinder by pump.
	Pressure increase	OFF (Open)	OFF (Closed)	Master cylinder brake fluid pressure is transmitted to caliper.

# ANTI-LOCK BRAKE SYSTEM

## Removal and Installation

### CAUTION:

Be careful not to damage sensor edge and sensor rotor teeth. When removing the front wheel hub or final drive assemblies, first remove the ABS wheel sensor from the assembly. Failure to do so may result in damage to the sensor wires making the sensor inoperative.

### WHEEL SENSORS

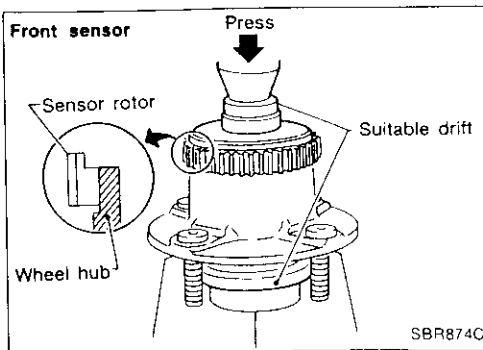
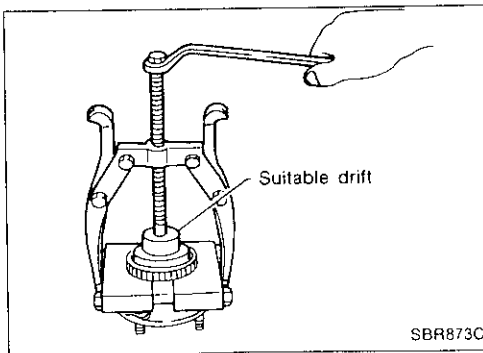
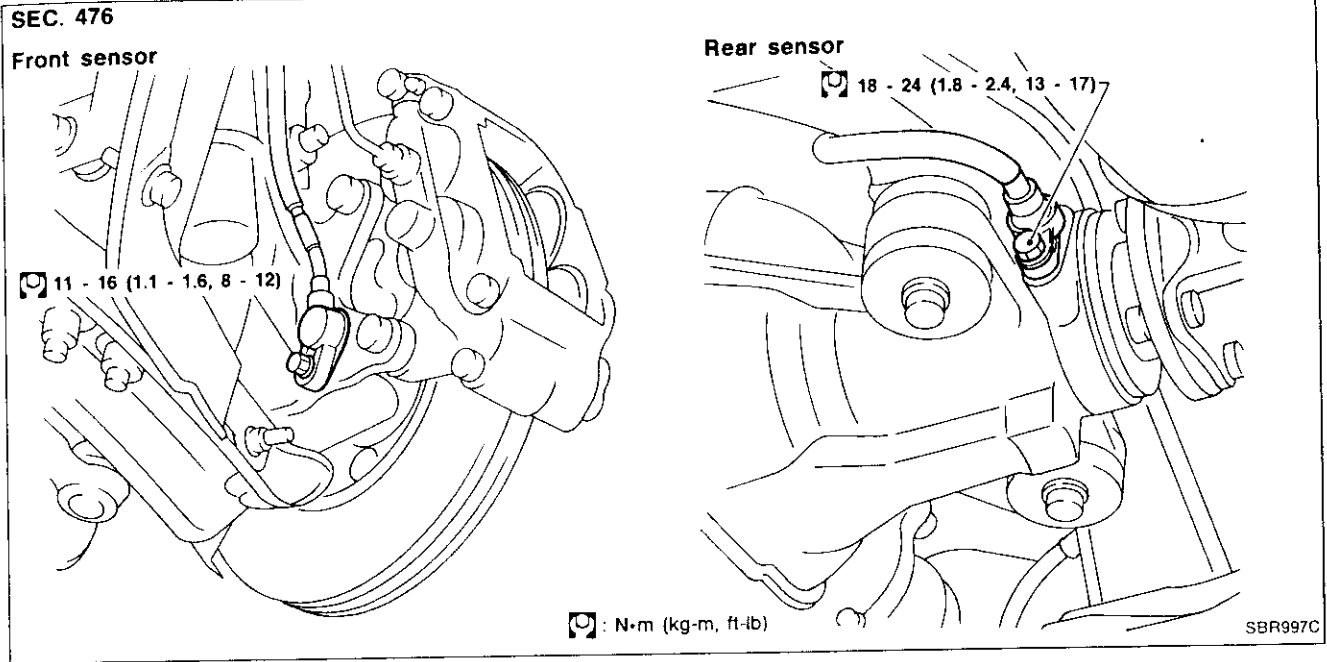

### SENSOR ROTOR

#### Removal

1. Remove the front wheel hub or final drive companion flange. Refer to FA and PD sections.
2. Remove the sensor rotor using suitable puller, drift and bearing replacer.

#### Installation

Install the sensor rotor using suitable drift and press.

- Always replace sensor rotor with new one.
- Pay attention to the direction of front sensor rotor as show in figure.

ST  
WA  
EV  
LC  
EC  
EE  
CL  
WT  
AT  
PD  
FA  
RA  
BR  
ST  
BS  
RF  
HA  
EL  
DX

## ANTI-LOCK BRAKE SYSTEM

### Removal and Installation (Cont'd)

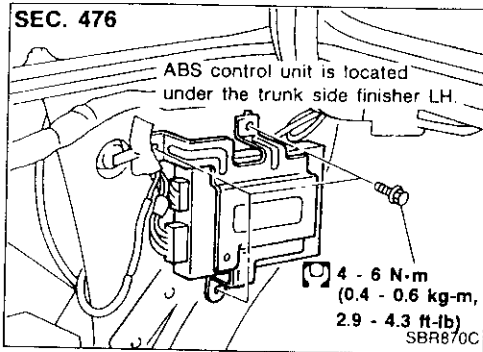
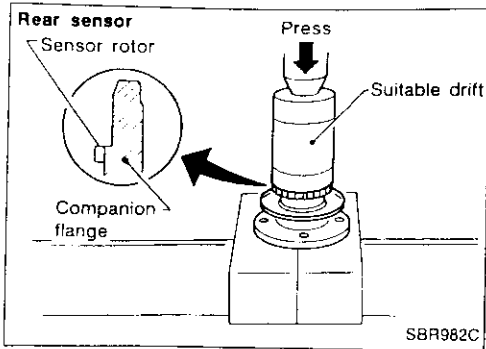

### CONTROL UNIT

Location: Under trunk side finisher LH.

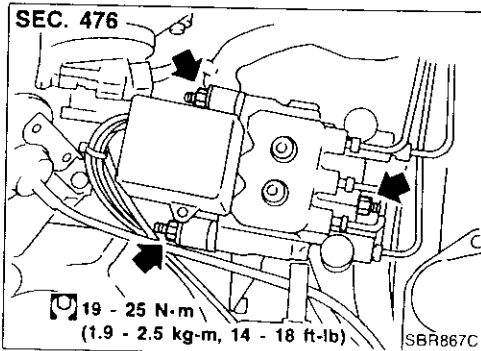

### ACTUATOR

#### Removal

1. Disconnect battery cable.
2. Drain brake fluid. Refer to "Changing Brake Fluid" (BR-5).
3. Apply different colored paint to each pipe connector and actuator to prevent incorrect connection.
4. Disconnect connector, brake pipes and remove fixing nuts and actuator ground cable.

#### Installation

#### CAUTION:

After installation, refill brake fluid. Then bleed air. Refer to "Bleeding Brake System" (BR-5).

1. Tighten actuator ground cable.  
**Place ground cable at a notch of mounting bracket.**
2. Connect brake pipes temporarily.
3. Tighten fixing nuts.
4. Tighten brake pipes.
5. Fix actuator harness clip on the mounting bracket.
6. Connect connector and battery cable.

### ACTUATOR RELAYS

1. Disconnect battery cable.
2. Remove actuator relay cover.
3. Pull out relays.

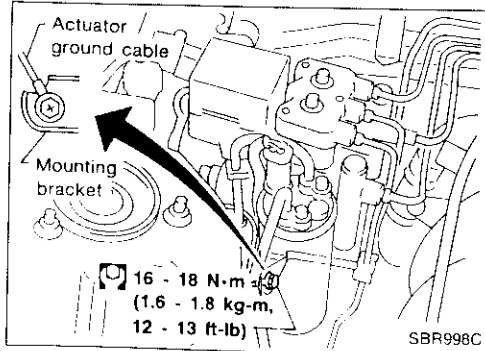

# ANTI-LOCK BRAKE SYSTEM

## Wiring Diagram — ABS —

LHD MODELS

BR-ABS-01

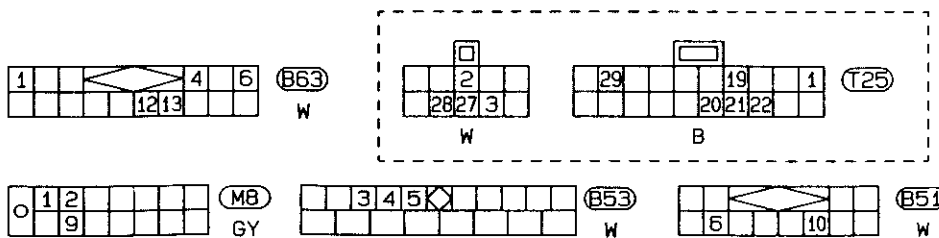
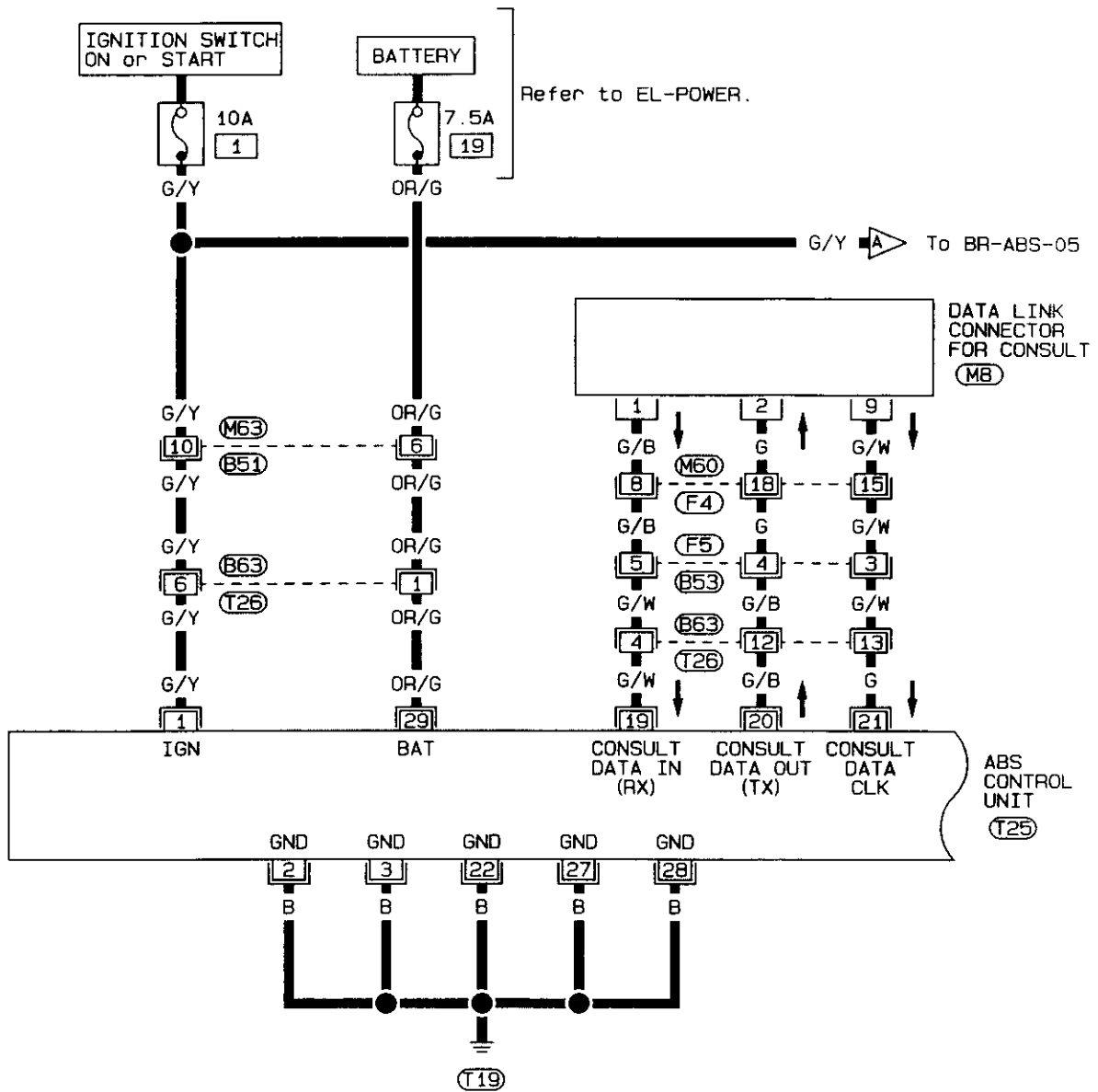

Refer to last page (Foldout page).

M60, F4

BR



# ANTI-LOCK BRAKE SYSTEM

## Wiring Diagram — ABS — (Cont'd)

BR-ABS-02

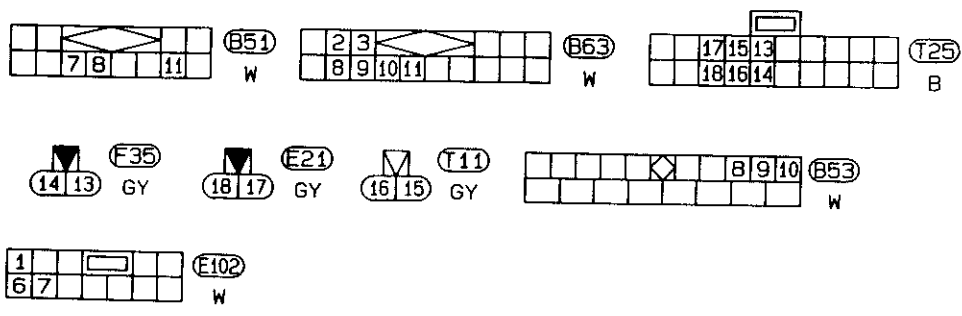
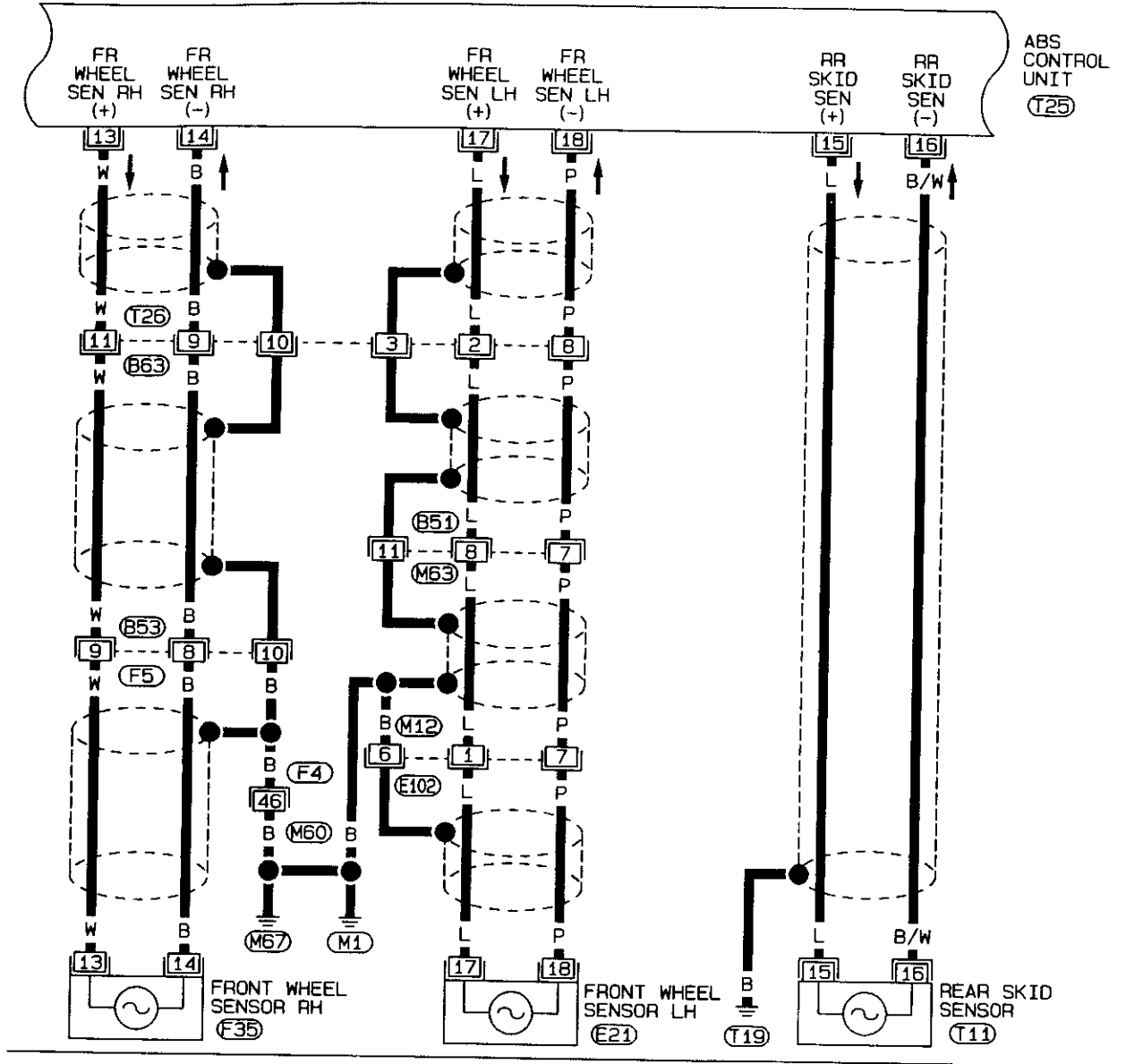

Refer to last page (Foldout page).

M60, F4

# ANTI-LOCK BRAKE SYSTEM

## Wiring Diagram — ABS — (Cont'd)

BR-ABS-03

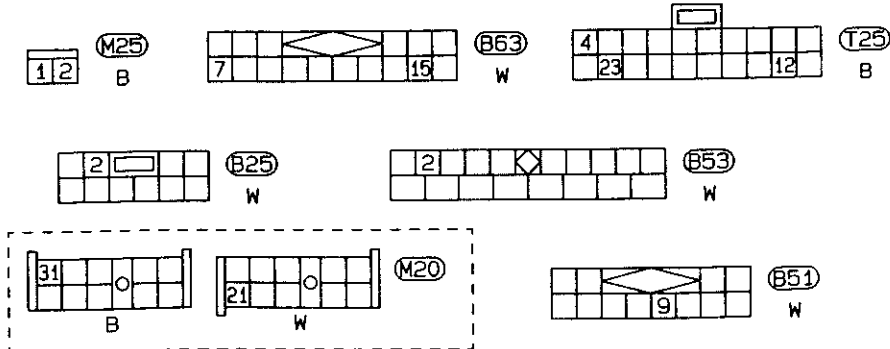
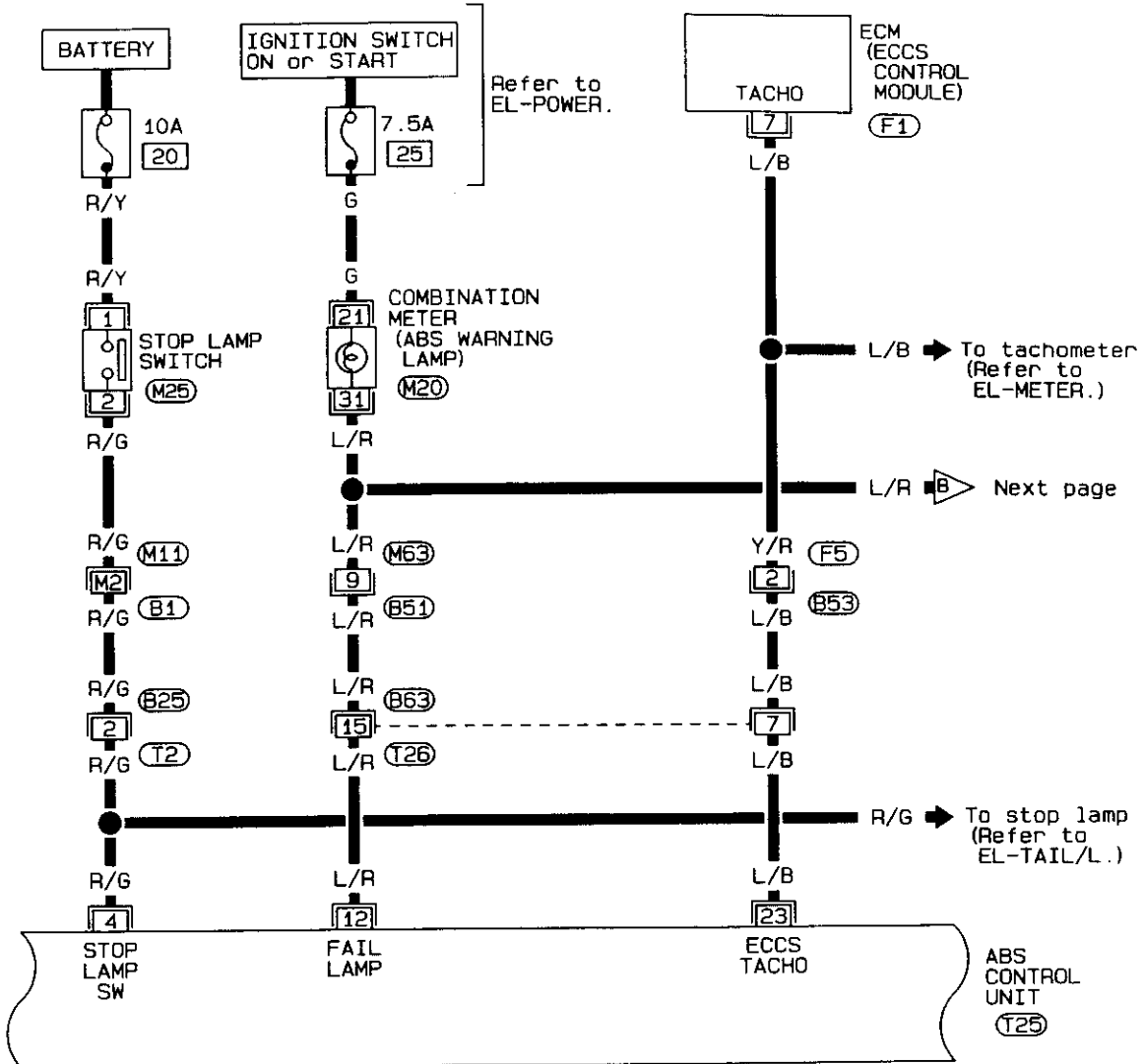

Refer to last page (Foldout page).  
 (M11) (B1)  
 (F1)

SBR003D

# ANTI-LOCK BRAKE SYSTEM

## Wiring Diagram — ABS — (Cont'd)

BR-ABS-04

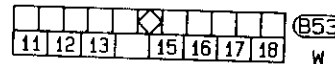
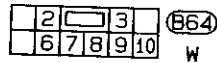
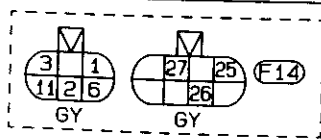
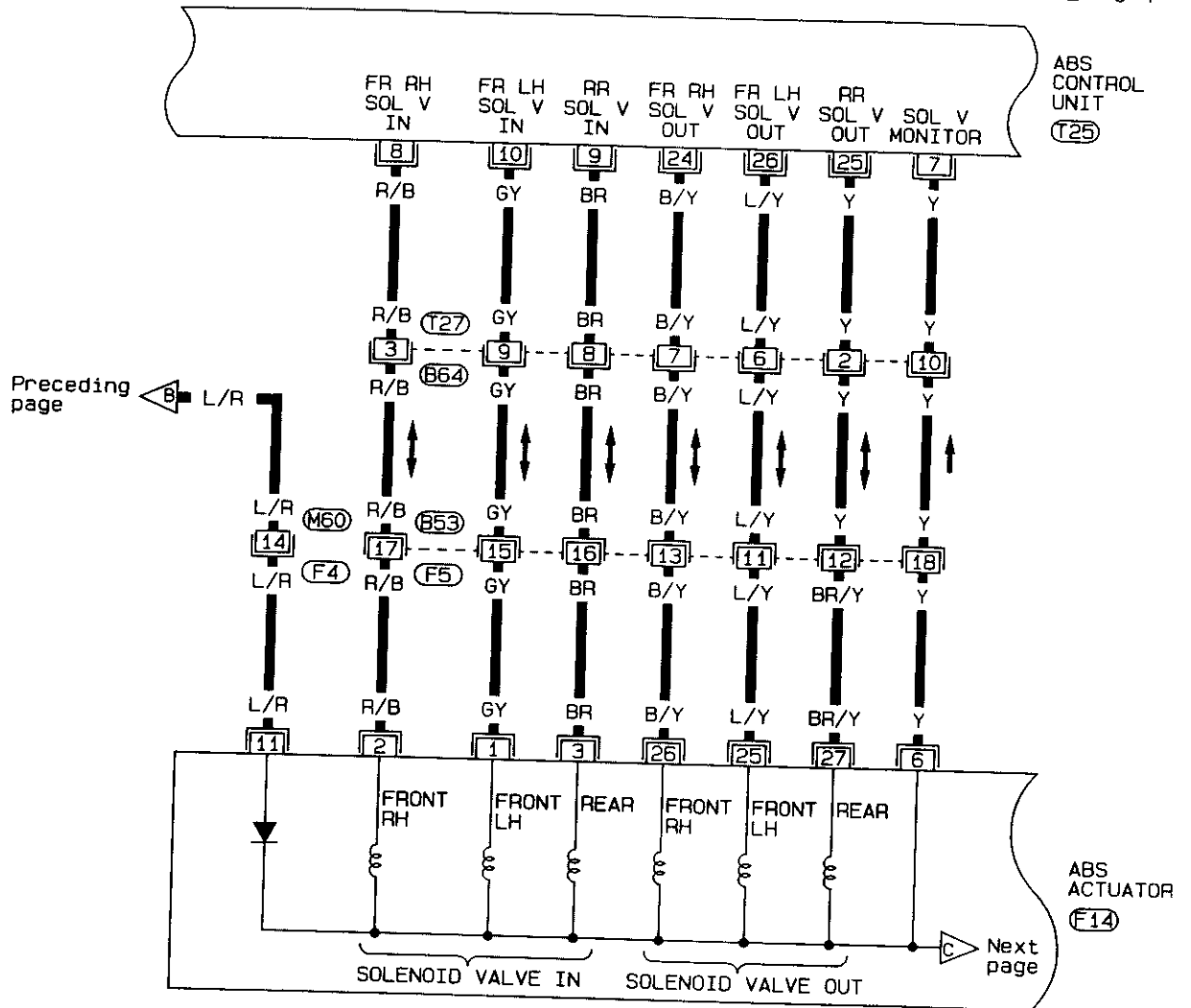

Refer to last page (Foldout page).

(M60) (F4)

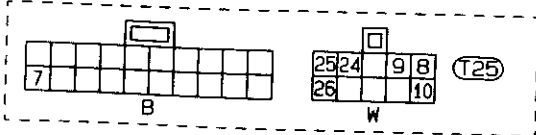

# ANTI-LOCK BRAKE SYSTEM

## Wiring Diagram — ABS — (Cont'd)

PP-ABS-05

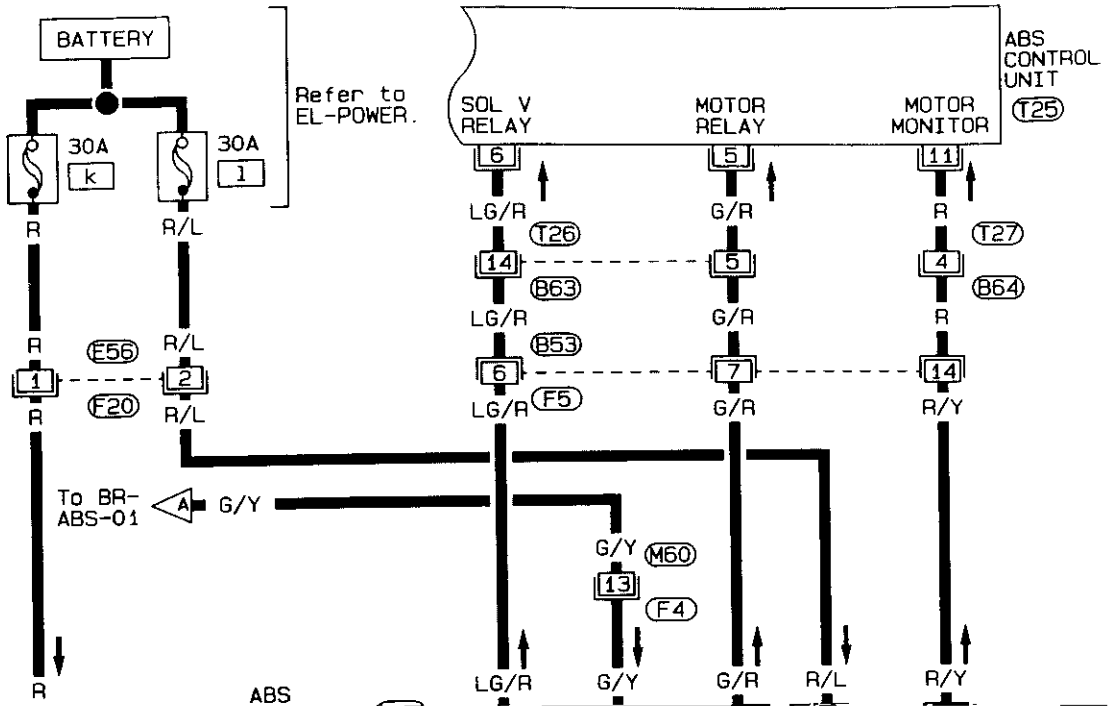

# ANTI-LOCK BRAKE SYSTEM

## Wiring Diagram — ABS — (Cont'd)

RHD MODELS

BR-ABS-06

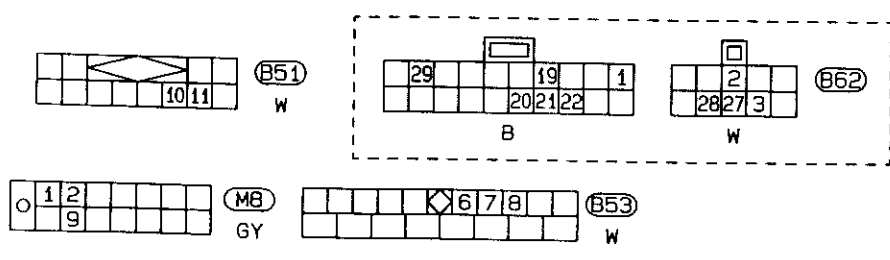
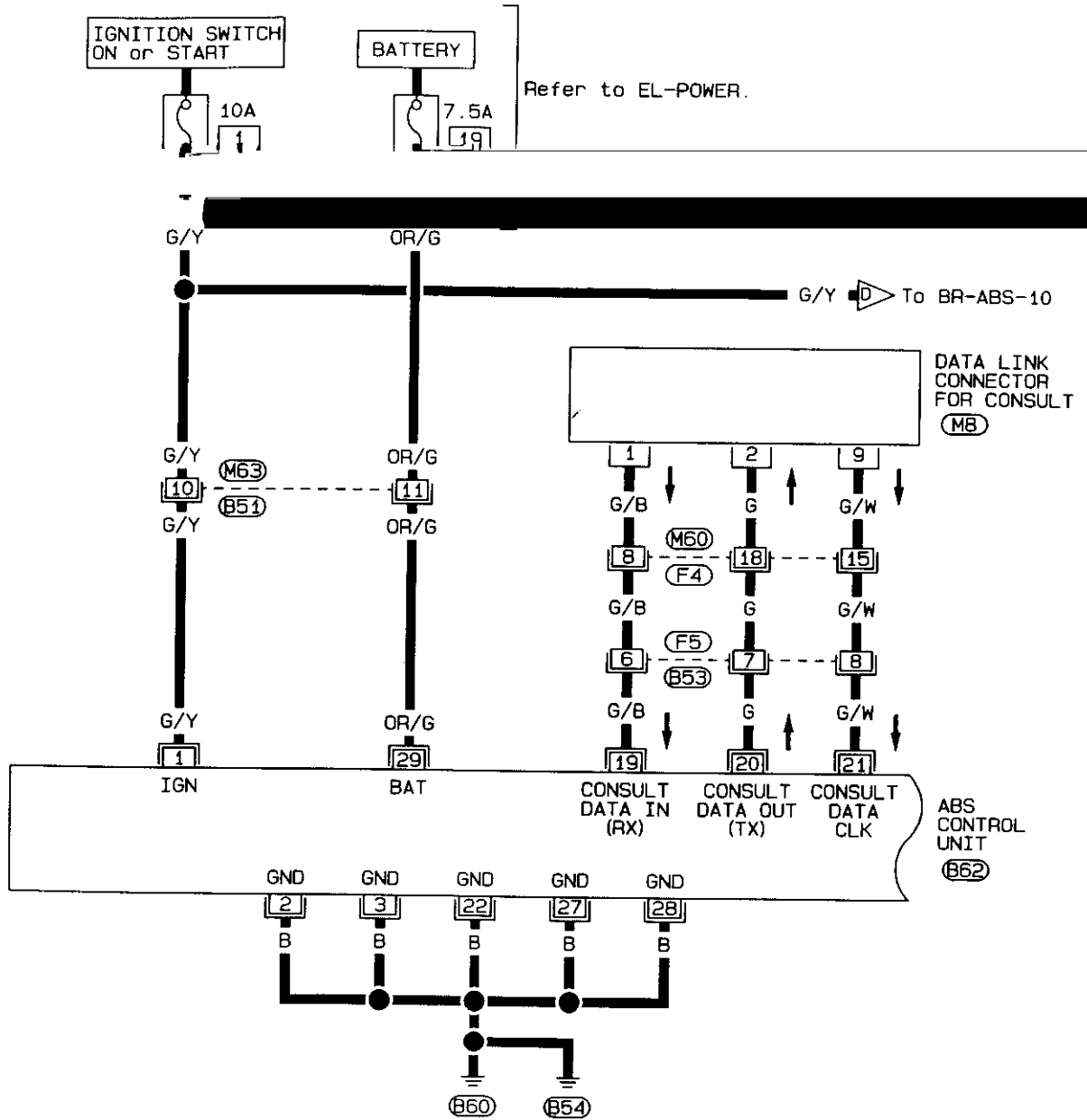

Refer to last page (Foldout page).

(M60), (F4)

# ANTI-LOCK BRAKE SYSTEM

## Wiring Diagram — ABS — (Cont'd)

BR-ABS-07

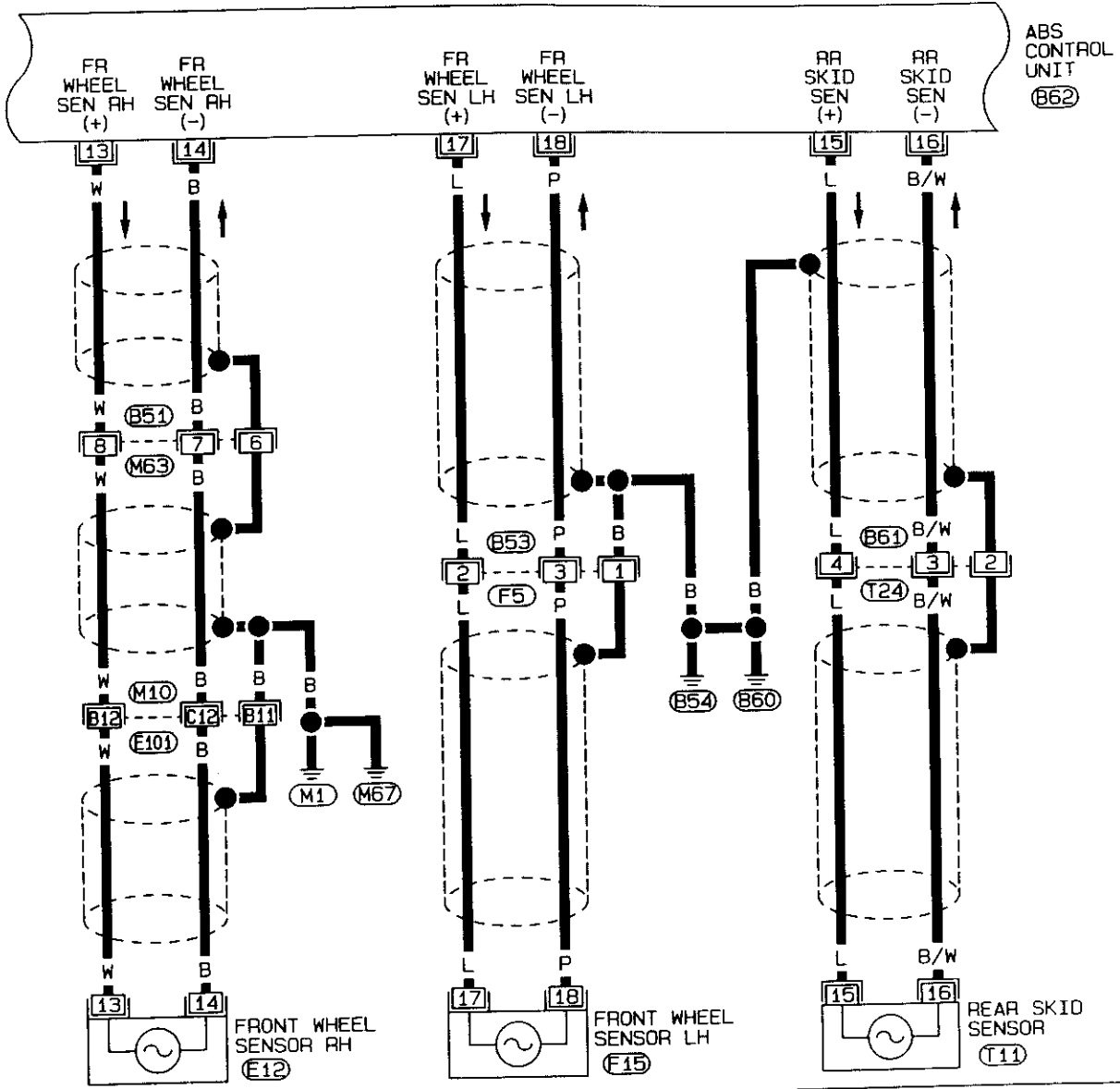

BR

Refer to last page (Foldout page).

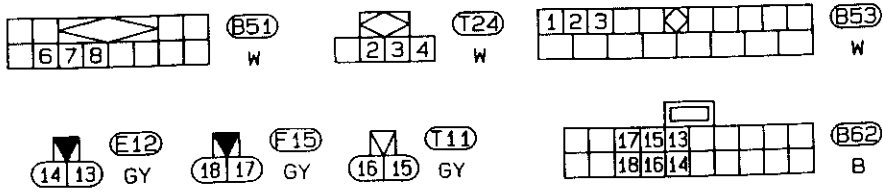

SBR007D

# ANTI-LOCK BRAKE SYSTEM

## Wiring Diagram — ABS — (Cont'd)

BR-ABS-08

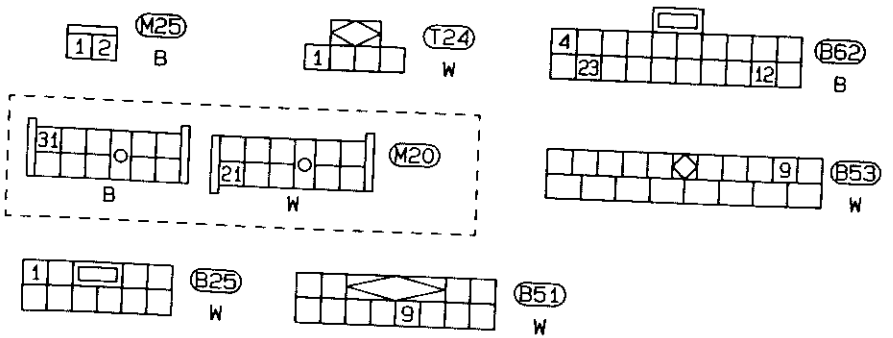
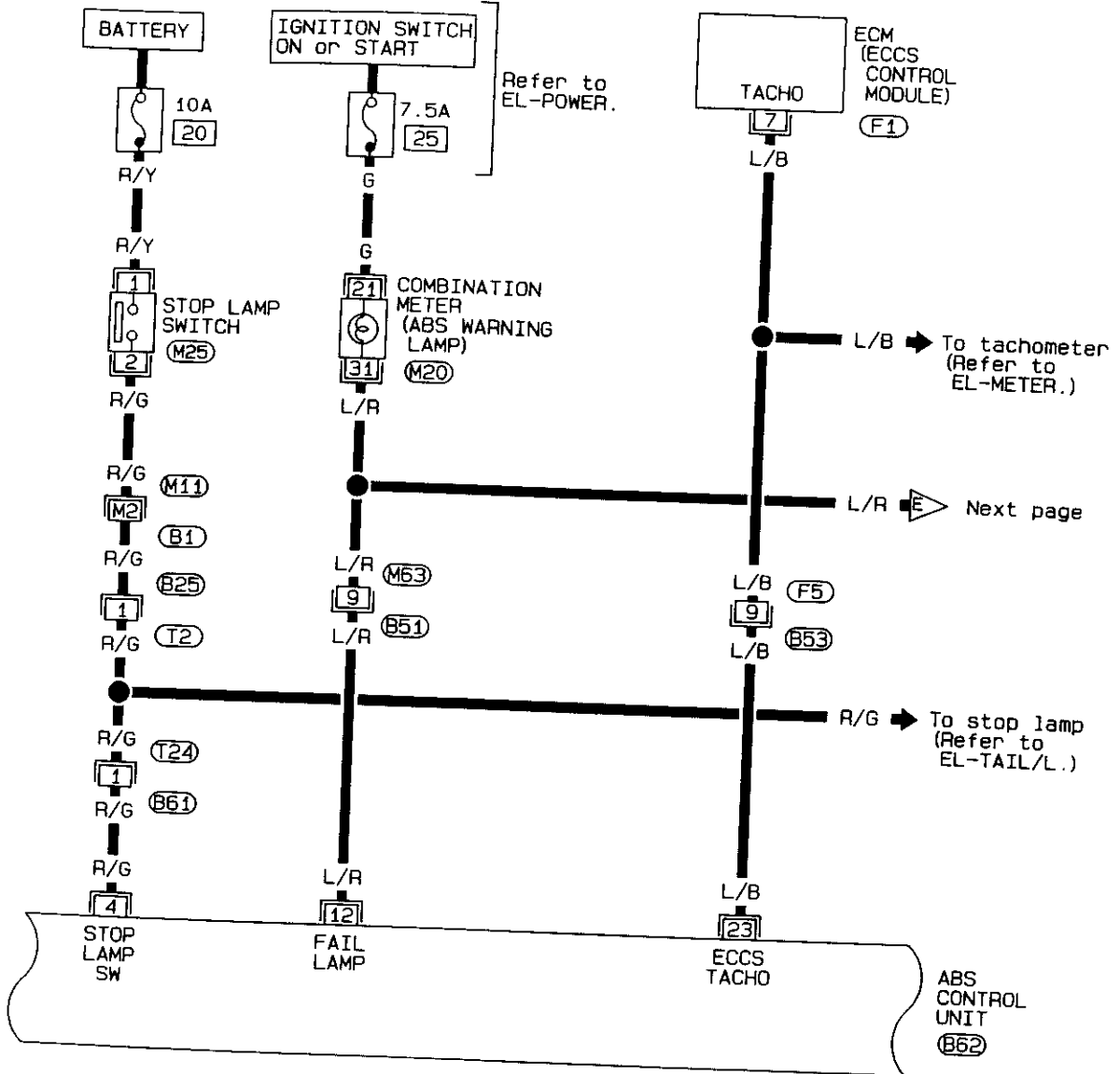

Refer to last page (Foldout page).

- (M11)
- (B1)
- (F1)

SBR008D

# ANTI-LOCK BRAKE SYSTEM

## Wiring Diagram — ABS — (Cont'd)

BR-ABS-09

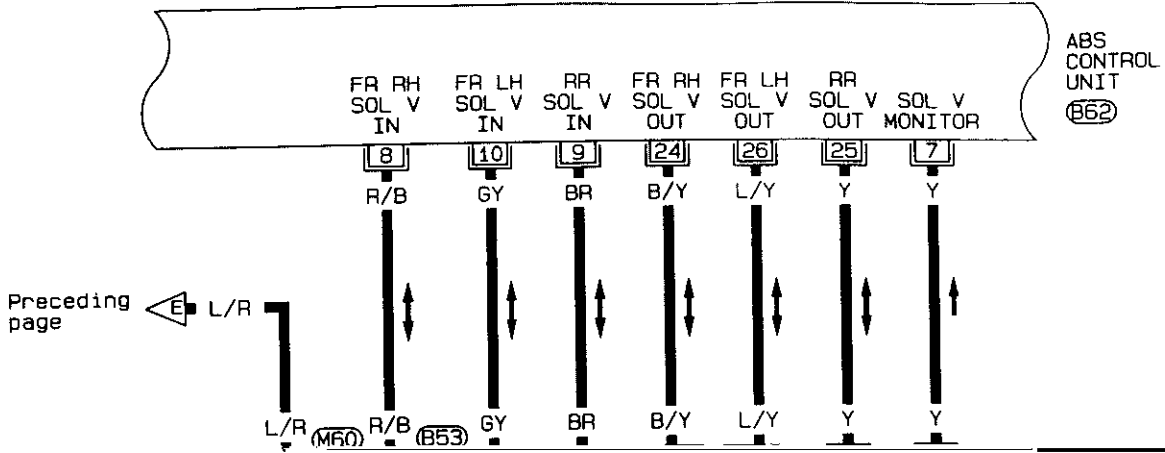



# ANTI-LOCK BRAKE SYSTEM

## Wiring Diagram — ABS — (Cont'd)

BR-ABS-10

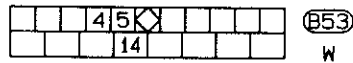
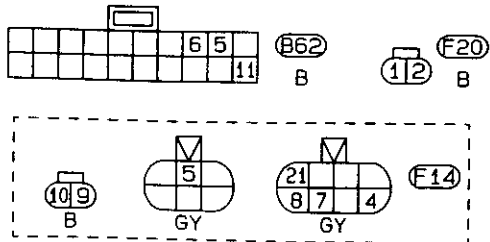
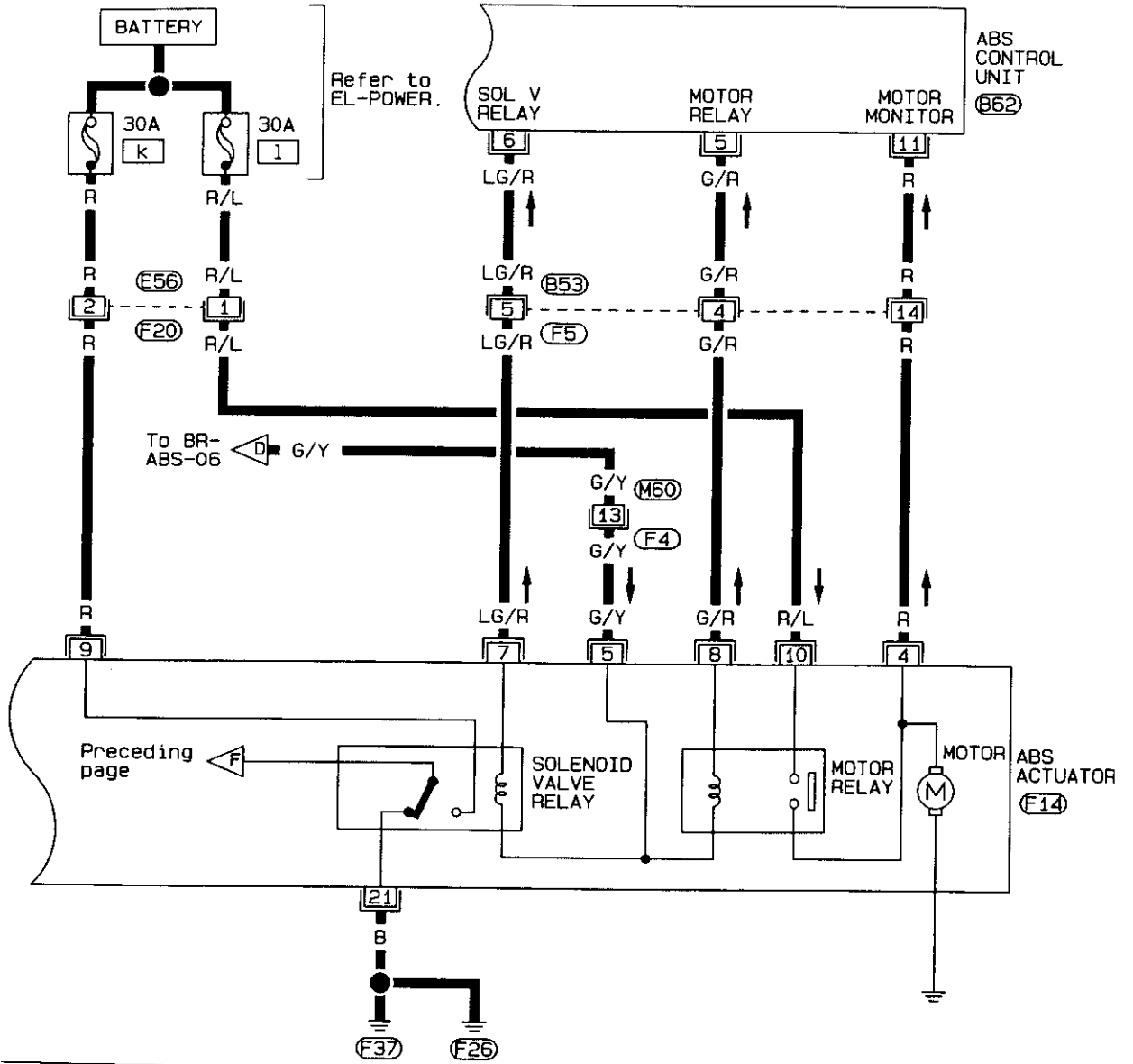

Refer to last page (Foldout page).

M60, F4

SBR010D

# TROUBLE DIAGNOSES

## Contents

How to Perform Trouble Diagnoses for Quick and Accurate Repair .....	BR-39
Self-diagnosis .....	BR-40
Component Parts and Harness Connector Location .....	BR-43
Preliminary Check .....	BR-44
Ground Circuit Check .....	BR-45
Circuit Diagram for Quick Pinpoint Check .....	BR-46
Diagnostic Procedure 1 Warning lamp does not work .....	BR-47
Diagnostic Procedure 2 Control unit or ground circuit .....	BR-49
Diagnostic Procedure 3 Actuator solenoid valve .....	BR-51
Diagnostic Procedure 4 Wheel sensor or rotor .....	BR-52
Diagnostic Procedure 5 Motor relay or motor .....	BR-54
Diagnostic Procedure 6 Solenoid valve relay .....	BR-57
Diagnostic Procedure 7 Power supply .....	BR-60
Diagnostic Procedure 8 Memory volt stop .....	BR-61
Diagnostic Procedure 9 Pedal vibration and noise .....	BR-62
Diagnostic Procedure 10 Long stopping distance .....	BR-63
Diagnostic Procedure 11 Unexpected pedal action .....	BR-63
Diagnostic Procedure 12 ABS does not work .....	BR-64
Diagnostic Procedure 13 ABS works frequently .....	BR-64
Electrical Component Inspection .....	BR-65

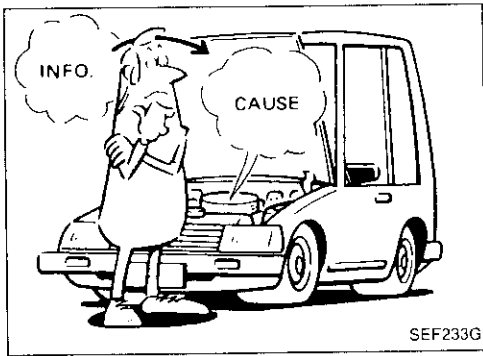

SEF233G

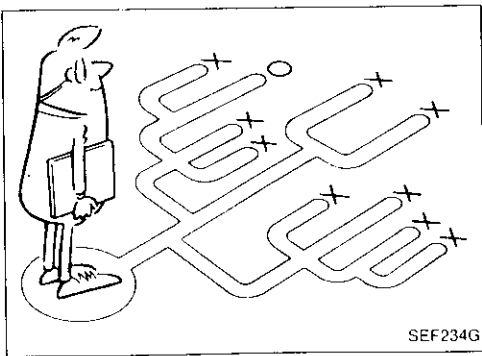

SEF234G

## How to Perform Trouble Diagnoses for Quick and Accurate Repair

### INTRODUCTION

The ABS system has an electronic control unit to control major functions. The control unit accepts input signals from sensors and instantly drives actuators. It is essential that both kinds of signals are proper and stable. It is also important to check for conventional problems: such as air leaks in the booster or lines, lack of brake fluid, or other problems with the brake system.

It is much more difficult to diagnose a problem that occurs intermittently rather than continuously. Most intermittent problems are caused by poor electric connections or faulty wiring. In this case, careful checking of suspicious circuits may help prevent the replacement of good parts.

A visual check only may not find the cause of the problems, so a road test should be performed.

Before undertaking actual checks, take just a few minutes to talk with a customer who approaches with a ABS complaint. The customer is a very good source of information on such problems; especially intermittent ones. Through the talks with the customer, find out what symptoms are present and under what conditions they occur.

Start your diagnosis by looking for "conventional" problems first. This is one of the best ways to troubleshoot brake problems on an ABS controlled vehicle.

# TROUBLE DIAGNOSES

## Self-diagnosis

### FUNCTION

- When a problem occurs in the ABS, the warning lamp on the instrument panel comes on.
- A maximum of three malfunctions are stored in the memory of the ABS control unit.

**Erase the self-diagnosis results stored in the control unit after malfunctions are repaired (See next page).**

- The self-diagnosis results are identified by Consult or LED on the control unit.

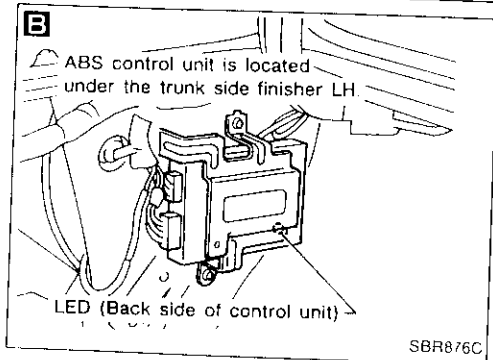
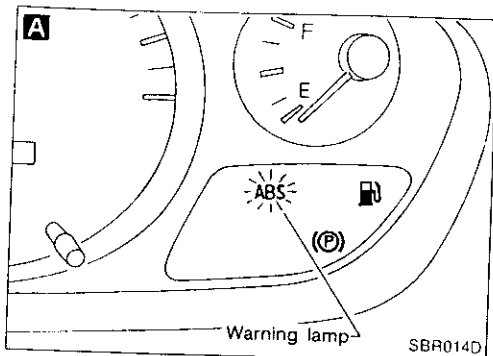

### SELF-DIAGNOSIS PROCEDURE

Start engine.

Drive vehicle over 15 km/h (9 MPH) for at least one minute.

**A**

Stop vehicle with engine running.

**Make sure that the ABS warning lamp activates.**

**B**

The LED on the ABS control unit flashes to indicate the malfunction code No.

Verify the location of the malfunction with the malfunction code chart. Then make necessary repairs following the diagnostic procedures.

After the malfunctions are repaired, erase the self-diagnostic results stored in the control unit.

**Disconnect connectors for ABS control unit or the battery negative terminal for at least one minute.**

Check warning lamp for deactivation after driving vehicle over 15 km/h (9 MPH) for at least one minute.

Test the ABS in a safe area to verify that it functions properly.

## TROUBLE DIAGNOSES

### Self-diagnosis (Cont'd)

#### HOW TO READ SELF-DIAGNOSTIC RESULTS (Malfunction codes)

- Determine the code No. by counting the number of times the LED flashes on and off.
- The malfunction code chart is given on the next page.

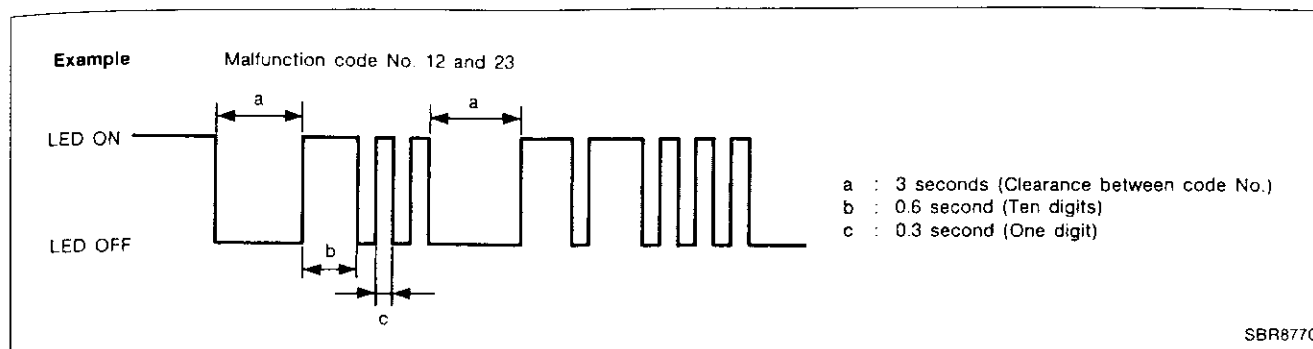

#### HOW TO ERASE SELF-DIAGNOSTIC RESULTS (Malfunction codes)

- Disconnect ABS control unit connectors or battery negative terminal for at least one minute.

BT  
MA  
EM  
LC  
EC  
FE  
CL  
MT  
AT  
PD  
FA  
BA  
BR  
ST  
PS  
BT  
HA  
EL  
OX

## TROUBLE DIAGNOSES

### Self-diagnosis (Cont'd)

#### MALFUNCTION CODE/SYMPTOM CHART

Code No. (No. of LED flashes)	Malfunctioning part and circuit	Diagnostic procedure
01	Front right sensor (open-circuit)	4
02	Front left sensor (open-circuit)	4
03	Rear sensor (open-circuit)	4
05	Front right sensor (short-circuit)	4
06	Front left sensor (short-circuit)	4
07	Rear sensor (short-circuit)	4
11	Actuator front right inlet solenoid valve (open-circuit)	3
12	Actuator front left inlet solenoid valve (open-circuit)	3
13	Actuator rear inlet solenoid valve (open-circuit)	3
15	Actuator front right outlet solenoid valve (open-circuit)	3
16	Actuator front left outlet solenoid valve (open-circuit)	3
17	Actuator rear outlet solenoid valve (open-circuit)	3
21	Actuator front right inlet solenoid valve (short-circuit)	3
22	Actuator front left inlet solenoid valve (short-circuit)	3
23	Actuator rear inlet solenoid valve (short-circuit)	3
25	Actuator front right outlet solenoid valve (short-circuit)	3
26	Actuator front left outlet solenoid valve (short-circuit)	3
27	Actuator rear outlet solenoid valve (short-circuit)	3
41	Solenoid valve relay circuit (unable to turn off)	6
42	Solenoid valve relay circuit (unable to turn on)	6
43	Actuator motor or motor relay (unable to turn off)	5
44	Actuator motor or motor relay (unable to turn on)	5
47	Power supply (High voltage)	7
48	Power supply (Low voltage)	7
45, 46, 77 LED deactivation or continuous activation	Control unit Ground circuit	2
Warning lamp does not come on when ignition switch is turned on.	Fuse, warning lamp bulb or warning lamp circuit Control unit power supply circuit	1
Pedal vibration and noise	—	9
Long stopping distance	—	10
Unexpected pedal action	—	11
ABS does not work.	—	12
ABS works frequently.	—	13

# TROUBLE DIAGNOSES

## Component Parts and Harness Connector Location

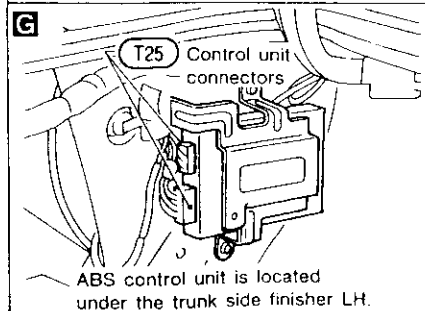
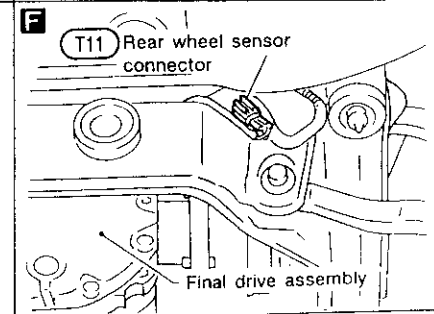
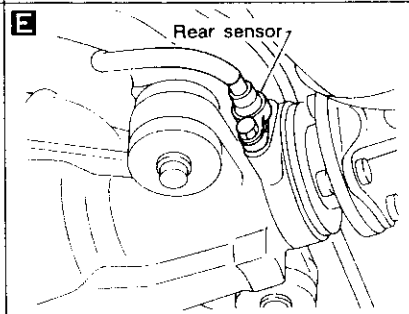
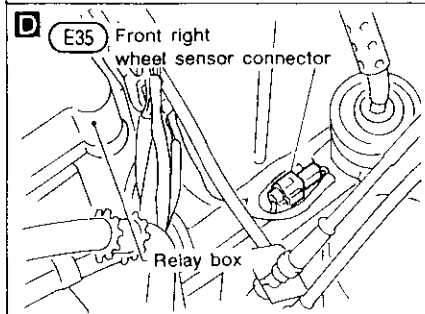
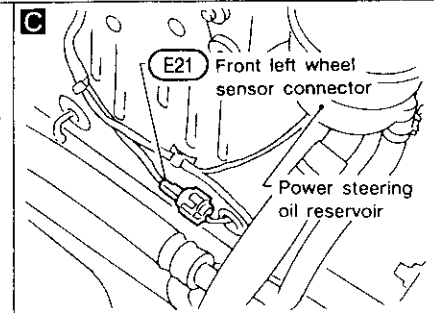
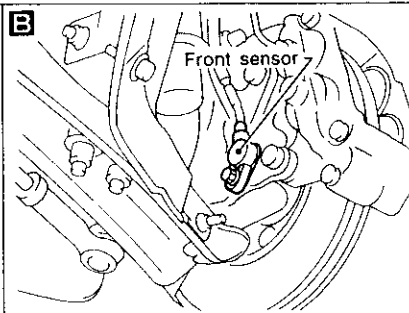
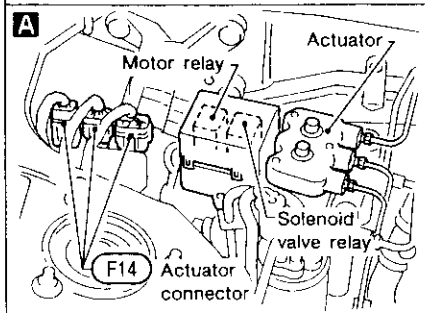
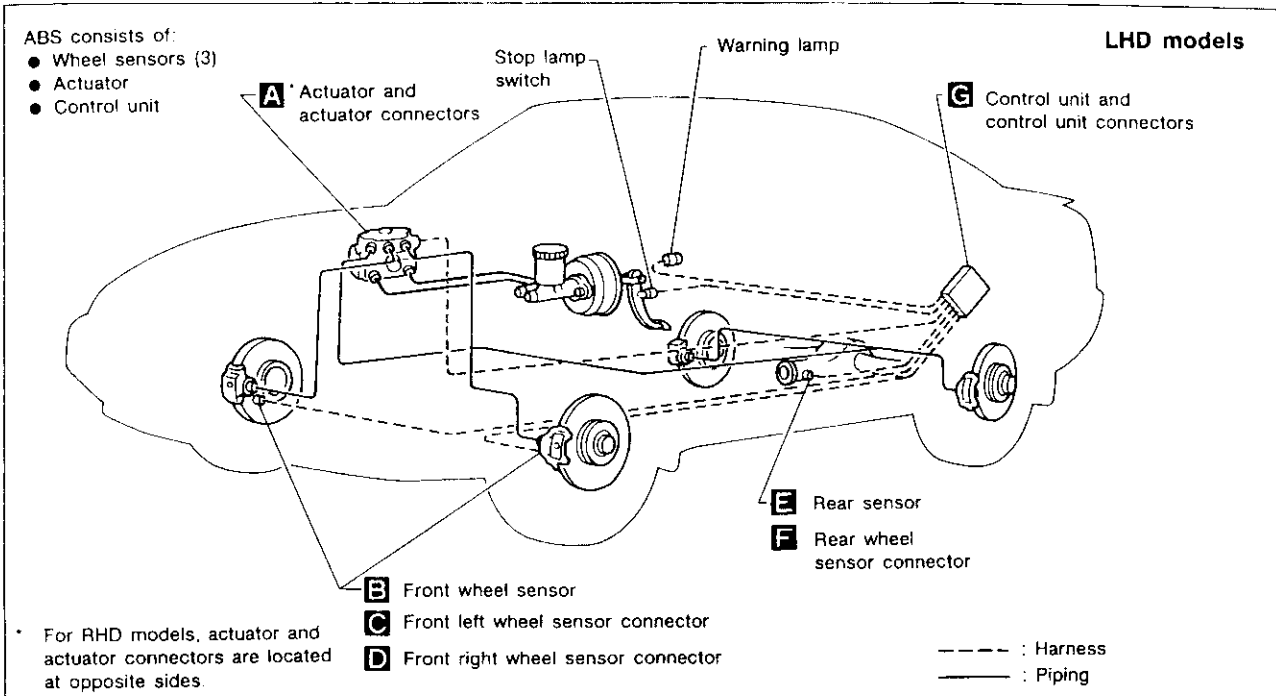

SBR011D

# TROUBLE DIAGNOSES

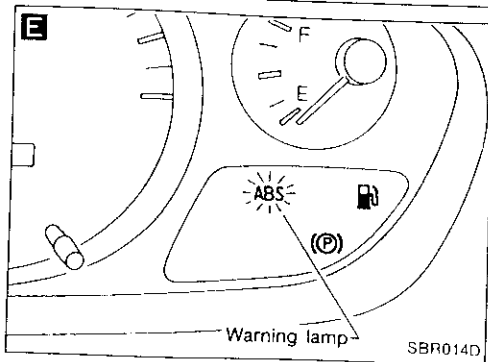
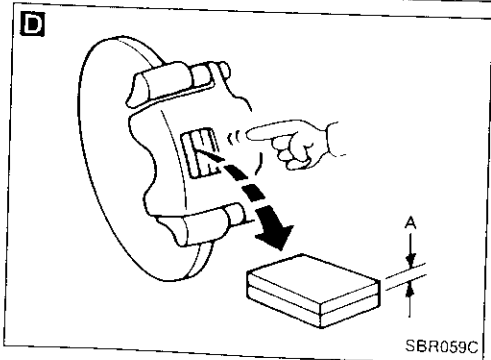
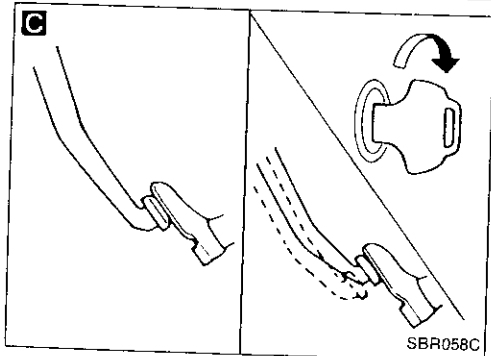
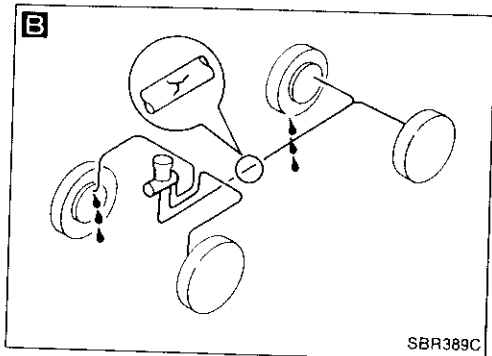
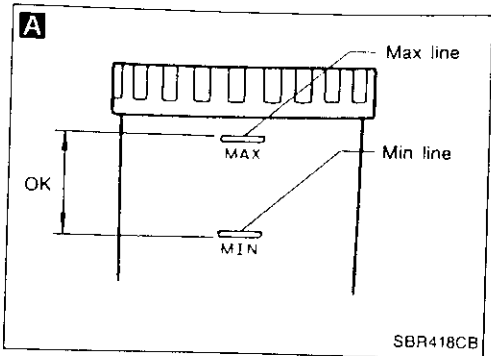

## Preliminary Check

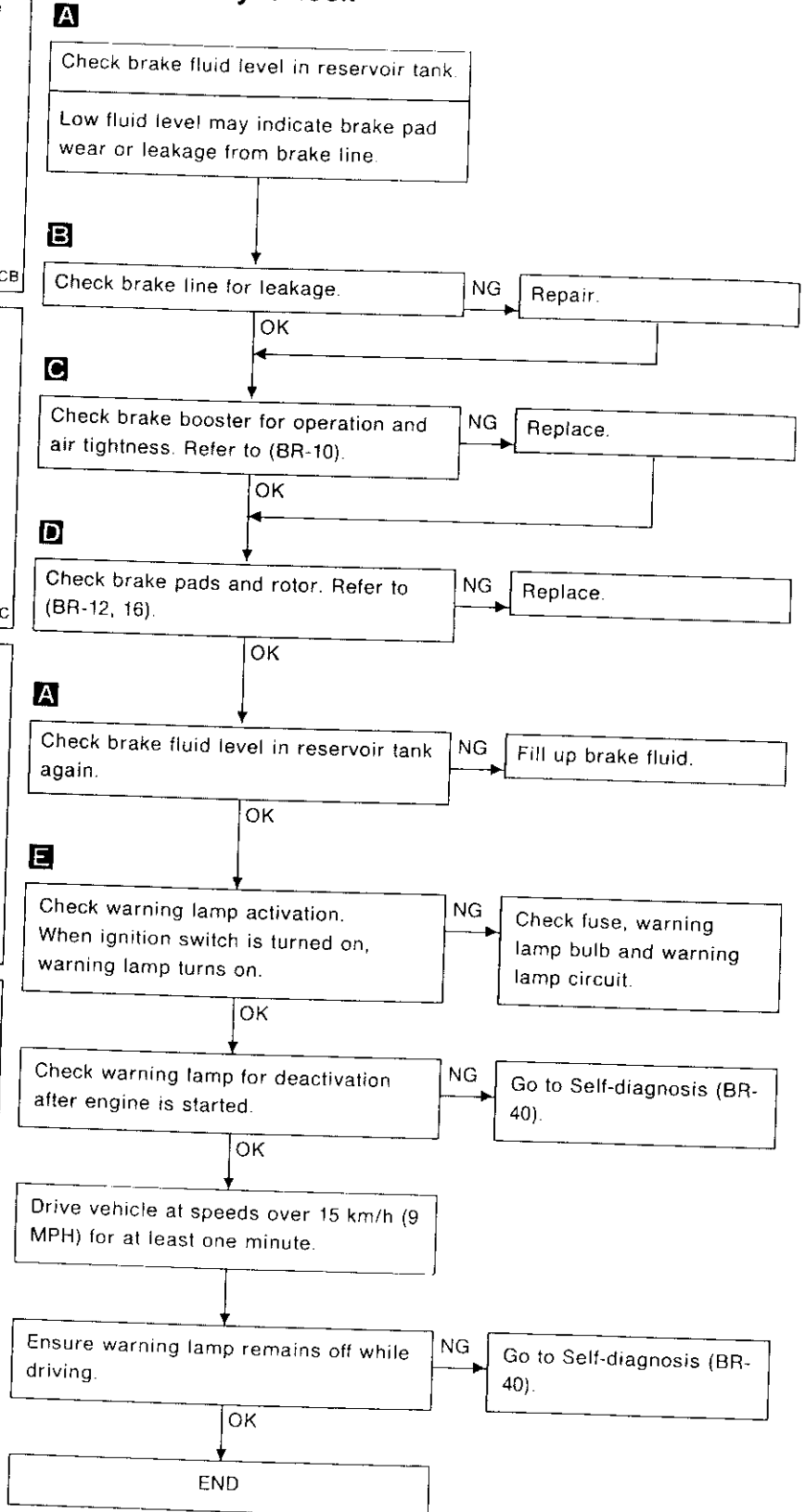

## TROUBLE DIAGNOSES

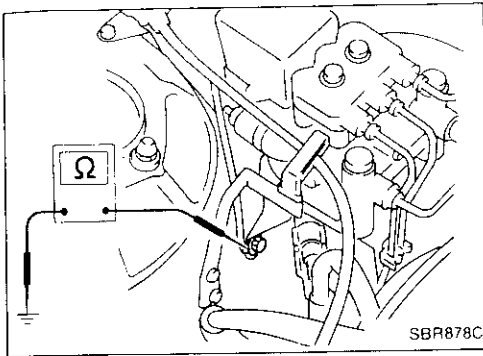

### Ground Circuit Check

#### ACTUATOR MOTOR GROUND

Actuator motor ground is secured with actuator mounting bracket bolt.

- Check resistance between actuator motor ground terminal and body ground.  
Resistance: approximately 0Ω

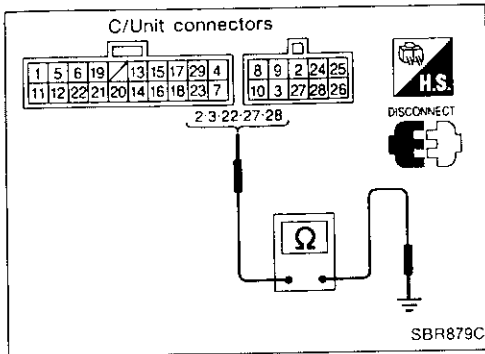

#### CONTROL UNIT GROUND

- Check resistance between control unit connector terminals and ground.  
Resistance: approximately 0Ω

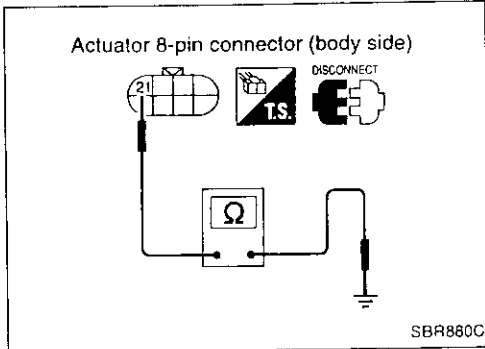

#### ACTUATOR GROUND

- Check resistance between actuator harness 8-pin connector (body side) terminal ② and ground.  
Resistance: approximately 0Ω

BR



# TROUBLE DIAGNOSES

## Circuit Diagram for Quick Pinpoint Check

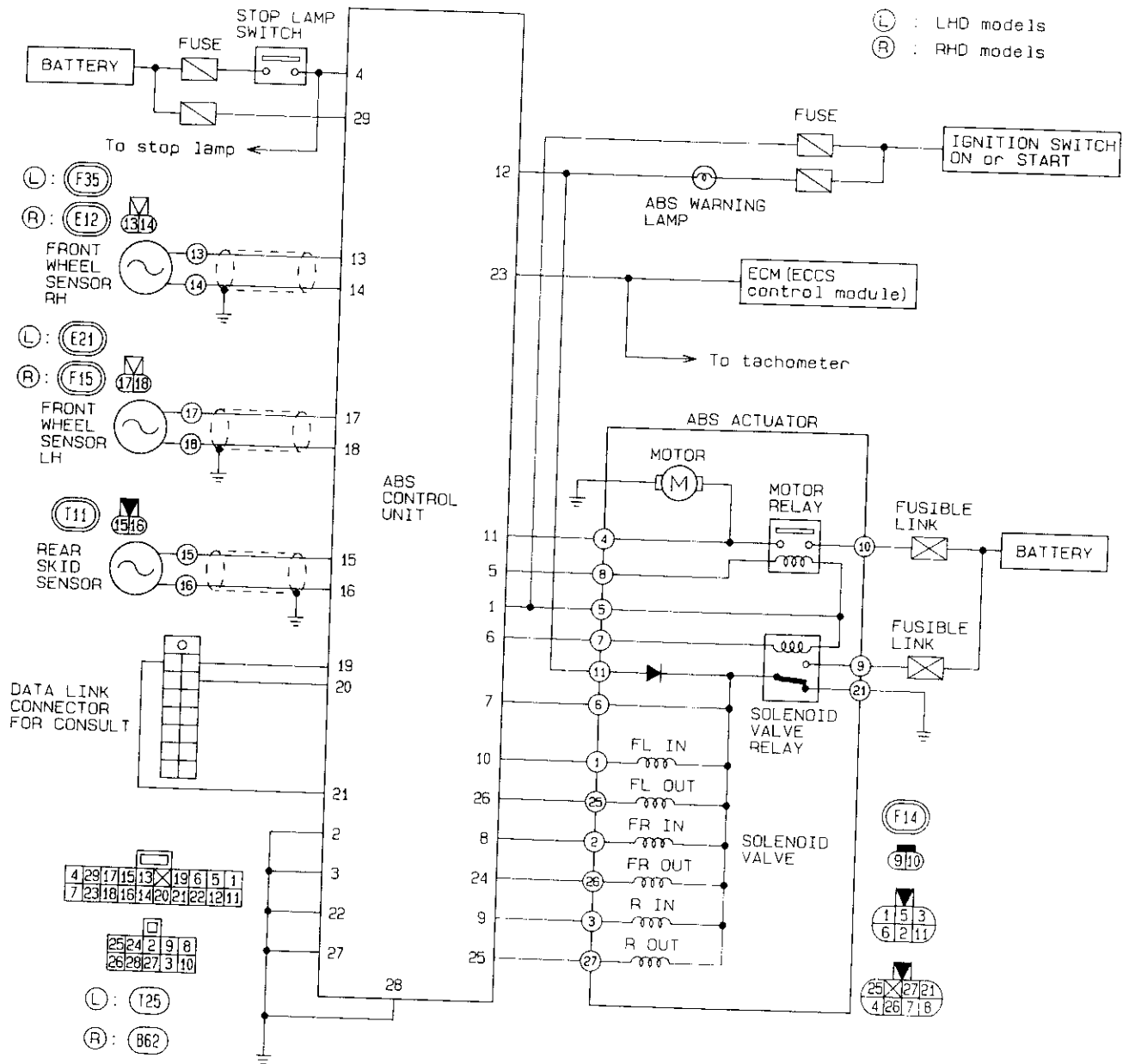

# TROUBLE DIAGNOSES

## Diagnostic Procedure 1 (Not self-diagnostic item)

Warning lamp does not work when ignition switch is turned ON.

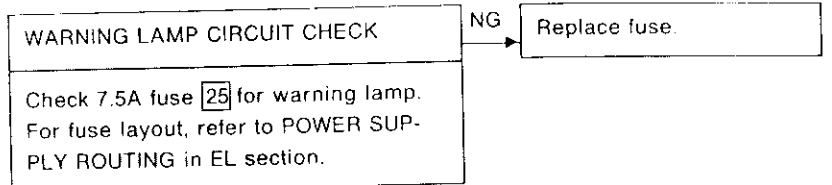

NG → Replace fuse.

Replace bulb.

NG → Check warning lamp bulb.

OK → Repair harness and connectors between battery and control unit connector terminal 12 (including combination meter)

NG → Repair harness and connectors between warning lamp (combination meter) and actuator 6-pin connector (body side) terminal 11.

NG → Repair harness and connectors.

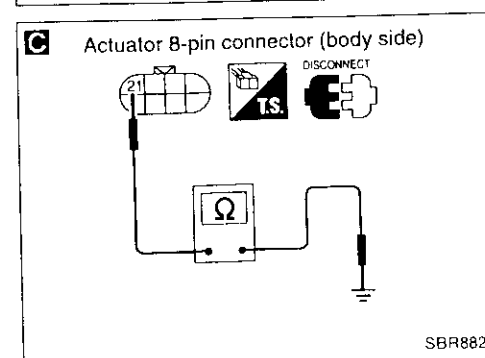
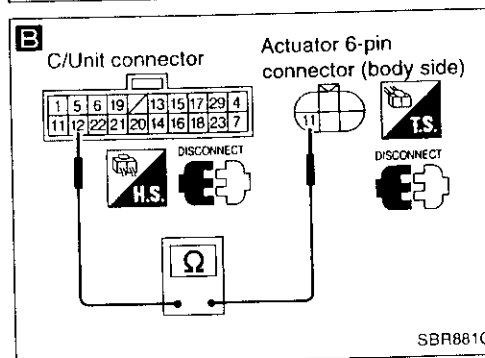
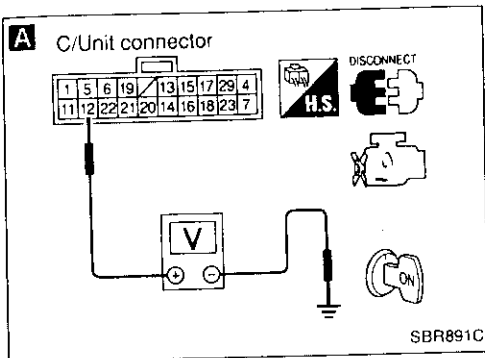

**A**

- Install 7.5A fuse.
- Disconnect connectors from control unit and actuator.
- Check voltage between control unit connector terminal 12 and ground after turning ignition switch "ON". **Battery voltage should exist after turning ignition switch "ON".**

**B**

- Turn ignition switch "OFF".
- Disconnect actuator 6-pin connector.
- Check continuity between control unit connector terminal 12 and actuator 6-pin connector (body side) terminal 11. **Continuity should exist.**

**C**

- Disconnect actuator 8-pin connector.
- Check continuity between actuator harness 8-pin connector (body side) terminal 21 and body ground. **Continuity should exist.**

OK → (A)  
(Go to next page.)

## TROUBLE DIAGNOSES

### Diagnostic Procedure 1 (Not self-diagnostic item) (Cont'd)

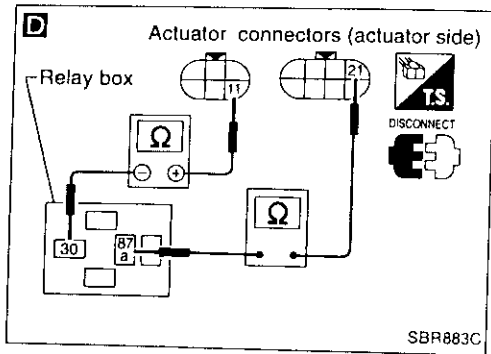

**D**

- Disconnect solenoid valve relay.
- Check continuity between actuator connector (actuator side) terminals and solenoid valve relay box terminals.

Actuator	Relay box
11 ⊕	30 ⊖
21	87a

Continuity should exist.

Note: Pay attention to tester polarity\*.

NG

Replace actuator assembly.

OK

CHECK SOLENOID VALVE RELAY.

Refer to SOLENOID VALVE RELAY in Electrical Components Inspection (BR-65).

NG

Replace solenoid valve relay.

OK

Go to **D** in Diagnostic Procedure 2.

\*: Specifications may vary depending on the type of tester. Before performing this inspection, refer to the instruction manual of the tester.

# TROUBLE DIAGNOSES

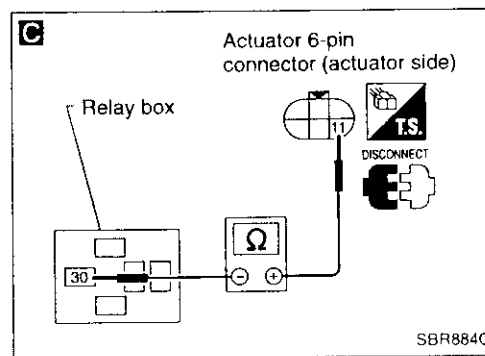
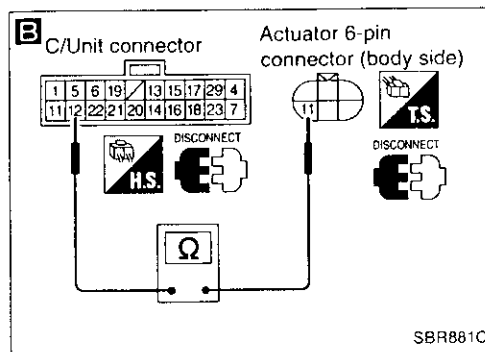
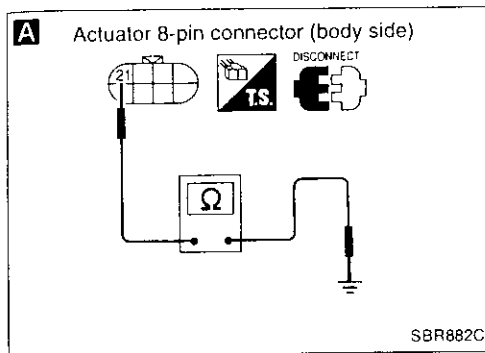

## Diagnostic Procedure 2

### CONTROL UNIT OR GROUND CIRCUIT

(Malfunction code No. 45, 46, 77, LED deactivation or continuous activation)

- Disconnect connectors from control unit and actuator. Check terminals for damage or connection. Then reconnect connectors.
  - Carry out self-diagnosis again.
- Does warning lamp activate again?**

No → Inspection end

Yes ↓

**SOLENOID VALVE RELAY CHECK**

Refer to SOLENOID VALVE RELAY in Electrical Components Inspection (BR-65).

NG → Replace solenoid valve relay.

OK ↓

**A** SOLENOID VALVE RELAY GROUND CIRCUIT

- Disconnect actuator 8-pin connector.
- Check continuity between actuator 8-pin connector (body side) terminal ② and body ground.

**Continuity should exist.**

NG → Repair harness and connectors.

OK ↓

**B**

- Disconnect control unit connectors and actuator 6-pin connector.
- Check continuity between control unit connector terminal ⑫ and actuator 6-pin connector (body side) terminal ⑪.

**Continuity should exist.**

NG → Repair harness and connectors.

OK ↓

**C**

- Check continuity between actuator 6-pin connector (actuator side) terminal ⑪ and solenoid valve relay box terminal ⑩.

Actuator	Relay box	Continuity
11 ⊕	30 ⊖	Yes
11 ⊖	30 ⊕	No

NG → Replace actuator assembly.

**Note: Pay attention to tester polarity\*.**

OK ↓

Ⓐ

(Go to next page.)

\*: Specifications may vary depending on the type of tester. Before performing this inspection, refer to the instruction manual of the tester.

# TROUBLE DIAGNOSES

## Diagnostic Procedure 2 (Cont'd)

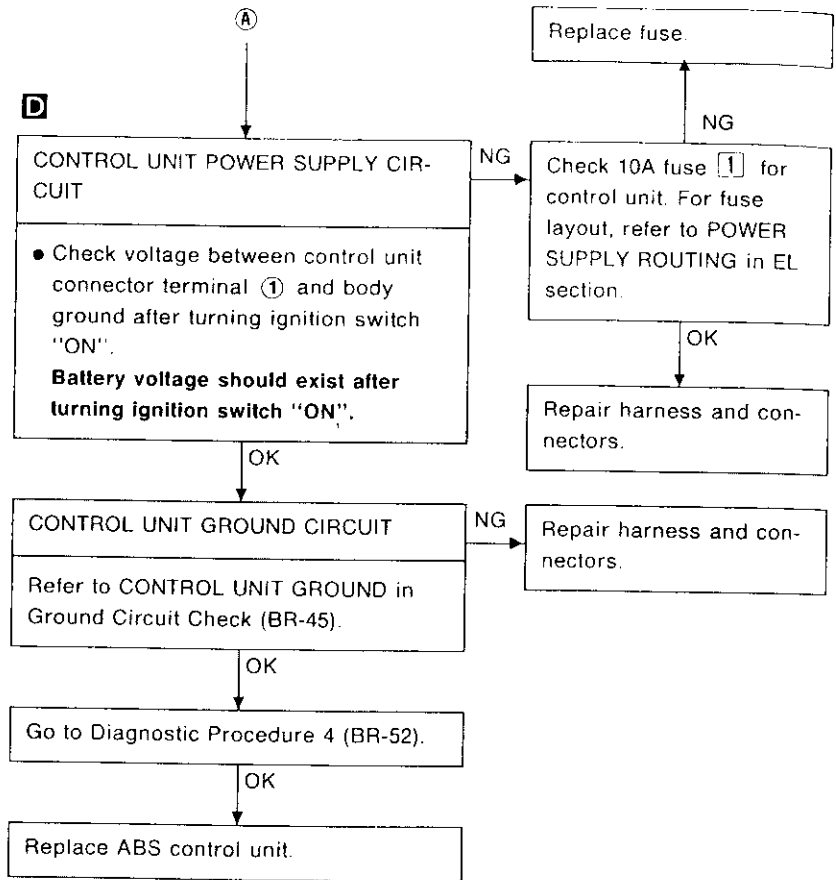
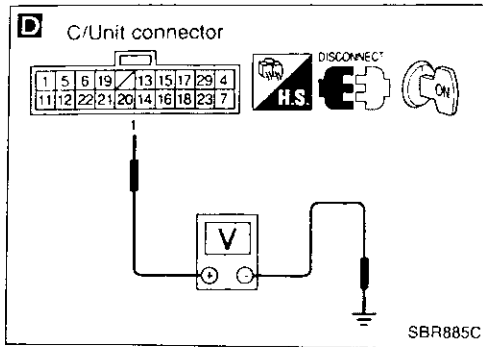

# TROUBLE DIAGNOSES

## Diagnostic Procedure 3

### ACTUATOR SOLENOID VALVE

(Malfunction code No. 11 - 13, 15 - 17, 21 - 23, 25 - 27)

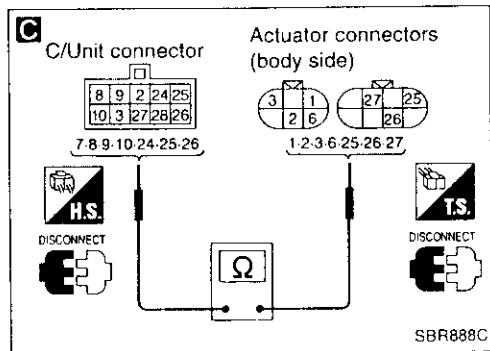
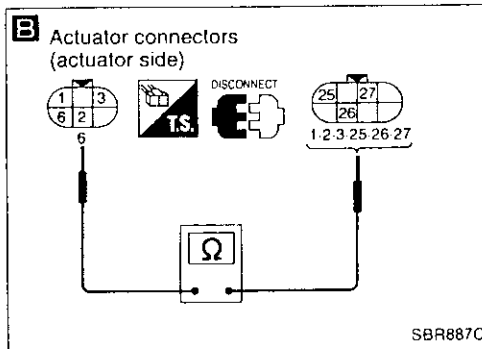
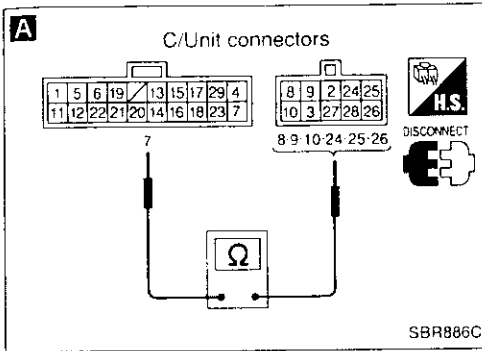

- Disconnect connectors from control unit and actuator. Check terminals for damage or loose connection. Then reconnect connectors.
  - Carry out self-diagnosis again.
- Does warning lamp activate again?**

No → Inspection end

Yes

- A** ACTUATOR SOLENOID VALVE CHECK
- Disconnect control unit connectors.
  - Check resistance between control unit connector terminals.

OK → Replace control unit.

Code No. (LED flashes)	Terminals
11, 21	(7) - (8)
12, 22	(7) - (10)
13, 23	(7) - (9)
15, 25	(7) - (24)
16, 26	(7) - (26)
17, 27	(7) - (25)

Resistance: 3.7 - 8.0Ω

NG

- B**
- Disconnect actuator connectors.
  - Check resistance between actuator connector (actuator side) terminals.

NG → Replace actuator.

Code No. (LED flashes)	Terminals
11, 21	(6) - (2)
12, 22	(6) - (1)
13, 23	(6) - (3)
15, 25	(6) - (26)
16, 26	(6) - (25)
17, 27	(6) - (27)

Resistance: 3.7 - 8.0Ω

OK

- C**
- Check continuity between control unit connector terminals and actuator connector (body side) terminals.

NG → Repair harness and connector.

Code No. (LED flashes)	Control unit	Actuator
11, 21	(8)	(2)
12, 22	(10)	(1)
13, 23	(9)	(3)
15, 25	(24)	(26)
16, 26	(26)	(25)
17, 27	(25)	(27)
42	(7)	(6)

Continuity should exist.

OK

(Go to next page.)

## TROUBLE DIAGNOSES

### Diagnostic Procedure 3 (Cont'd)

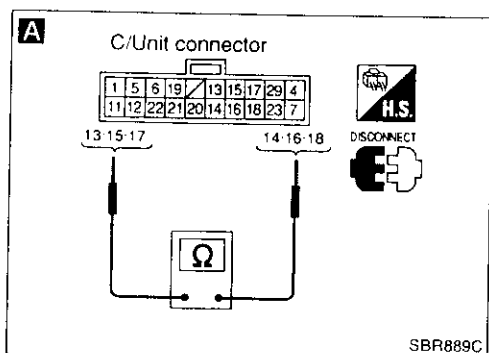
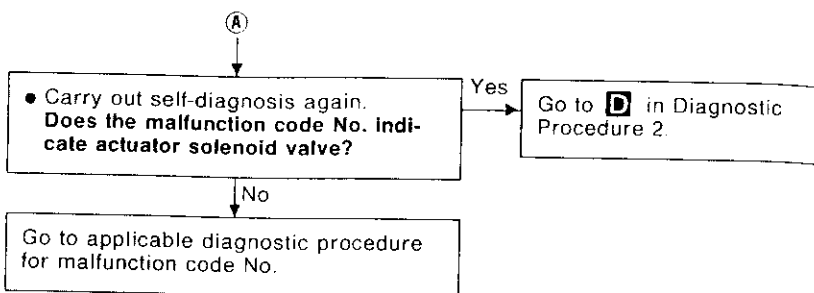

### Diagnostic Procedure 4

#### WHEEL SENSOR OR ROTOR

(Malfunction code No. 01 - 03, 05 - 07)

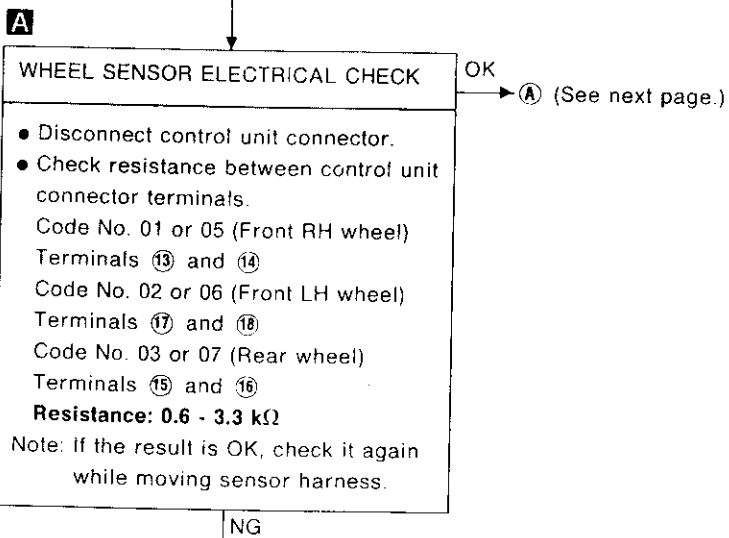
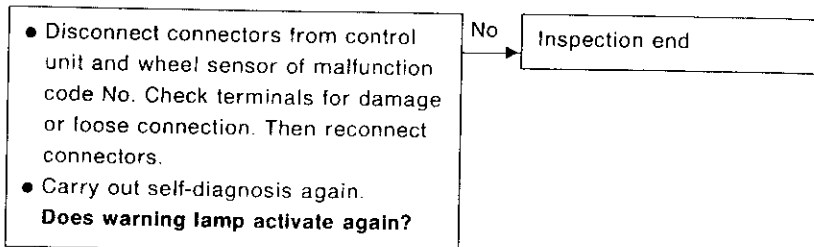

(Go to next page.)

**Note:** Wheel position should be distinguished by code No. (LED flashes).

# TROUBLE DIAGNOSES

## Diagnostic Procedure 4 (Cont'd)

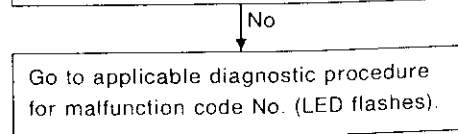
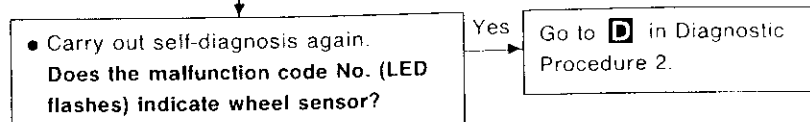
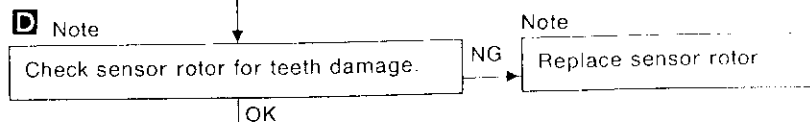
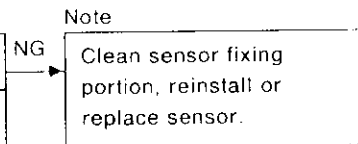
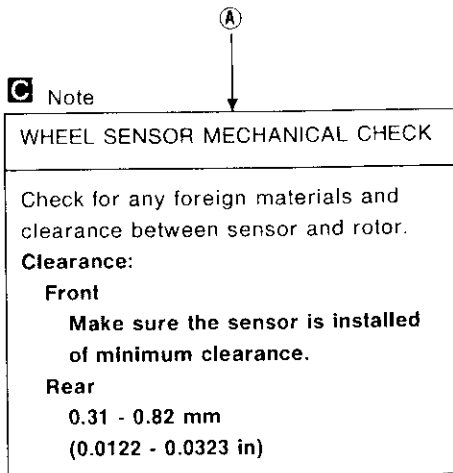
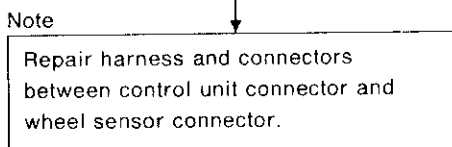
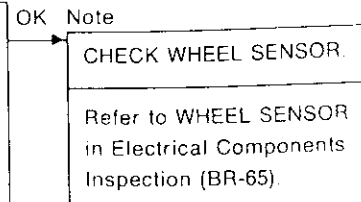
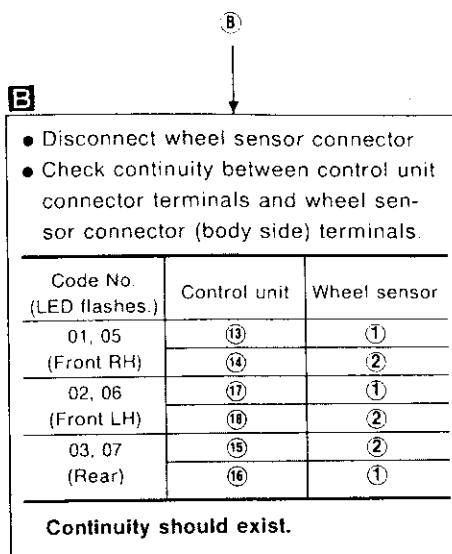
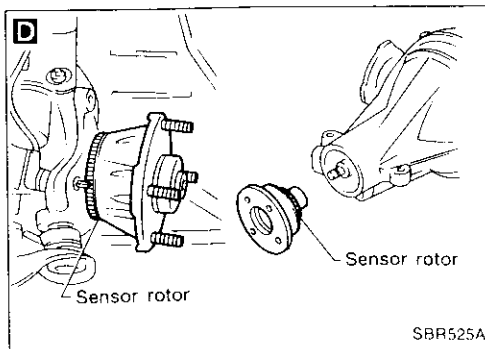
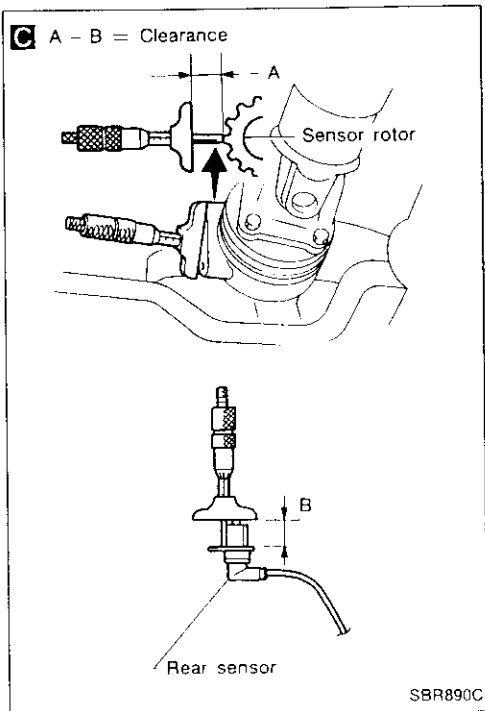
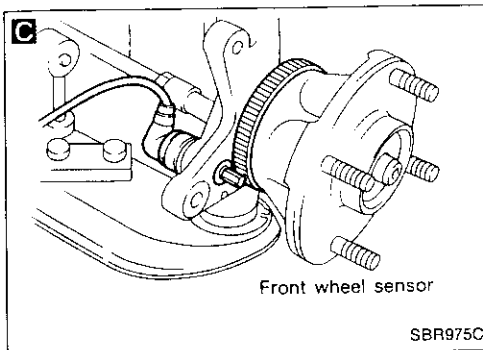
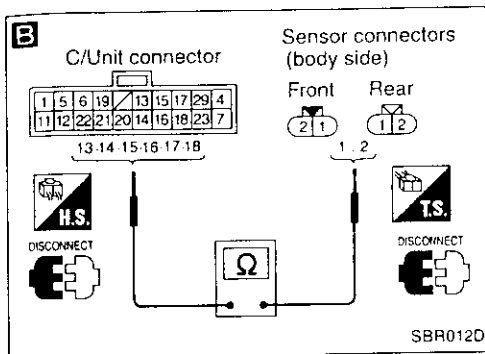

Note: Wheel position should be distinguished by code No. (LED flashes).



# TROUBLE DIAGNOSES

## Diagnostic Procedure 5 MOTOR RELAY OR MOTOR (Malfunction code No. 43, 44)

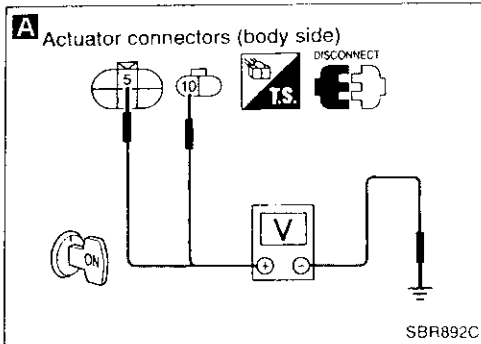

**MOTOR POWER SUPPLY CIRCUIT**

- Check 30A fusible link [L] and 10A fuse [I] for actuator. For fusible link and fuse layout, refer to POWER SUPPLY ROUTING in EL section.

NG → B (Skip page.)

OK

- Disconnect connectors from control unit and actuator. Check terminals for damage or loose connection. Then reconnect connectors.
- Carry out self-diagnosis again.  
**Does warning light activate again?**

No → Inspection end

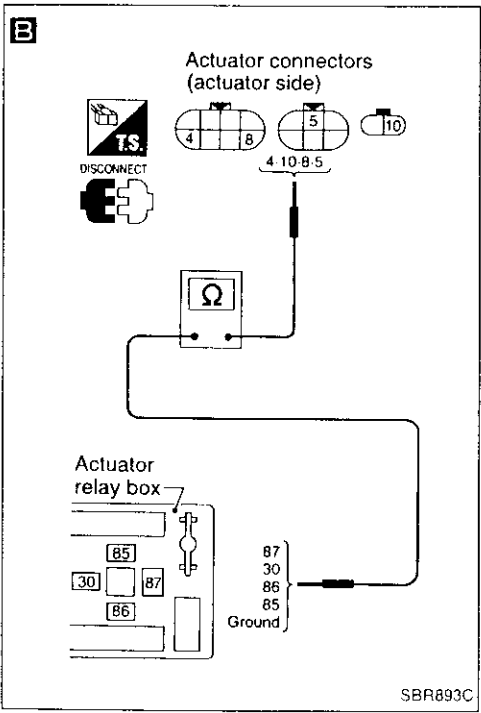

**A**

- Disconnect actuator connectors.
- Check voltage between connector (body side) terminals and ground.

Terminals	Ignition switch
⑤ - ground	ON position
⑩ - ground	---

**Battery voltage should exist.**

NG → Repair harness and connectors between battery and actuator connector (body side) terminals.

**B**

**MOTOR RELAY CIRCUIT**

- Remove motor relay.
- Disconnect actuator connectors.
- Check continuity between actuator connector (actuator side) terminals and relay connector terminals or body ground.

Actuator connector	Relay connector	Continuity
④	⑧	Yes
⑩	⑩	Yes
⑧	⑥	Yes
⑤	⑤	Yes
④	Ground	No

NG → Replace actuator assembly.

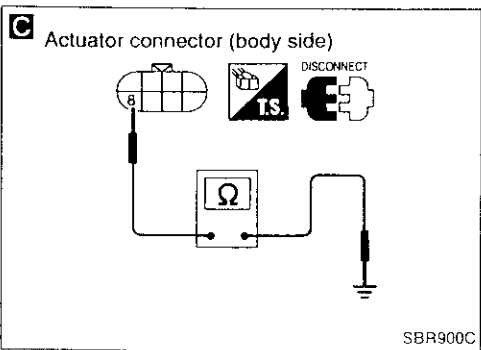

**C**

- Check continuity between actuator connector (body side) terminal ⑧ and ground.  
**Continuity should not exist.**

OK → A (Go to next page.)

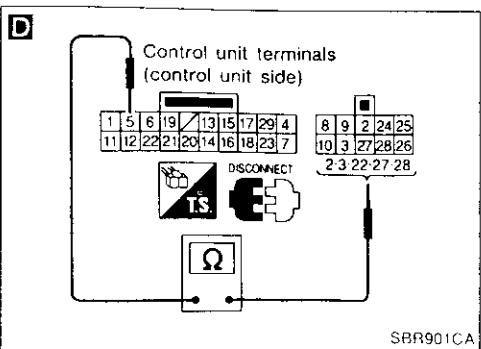

**D**

- Disconnect control unit connectors.
- Check continuity between control unit terminals (control unit side) ⑤ and ②, ③, ②②, ②⑦, ②⑧.  
**Continuity should not exist.**

OK → Repair harness and connectors.

NG → Replace control unit.

# TROUBLE DIAGNOSES

## Diagnostic Procedure 5 (Cont'd)

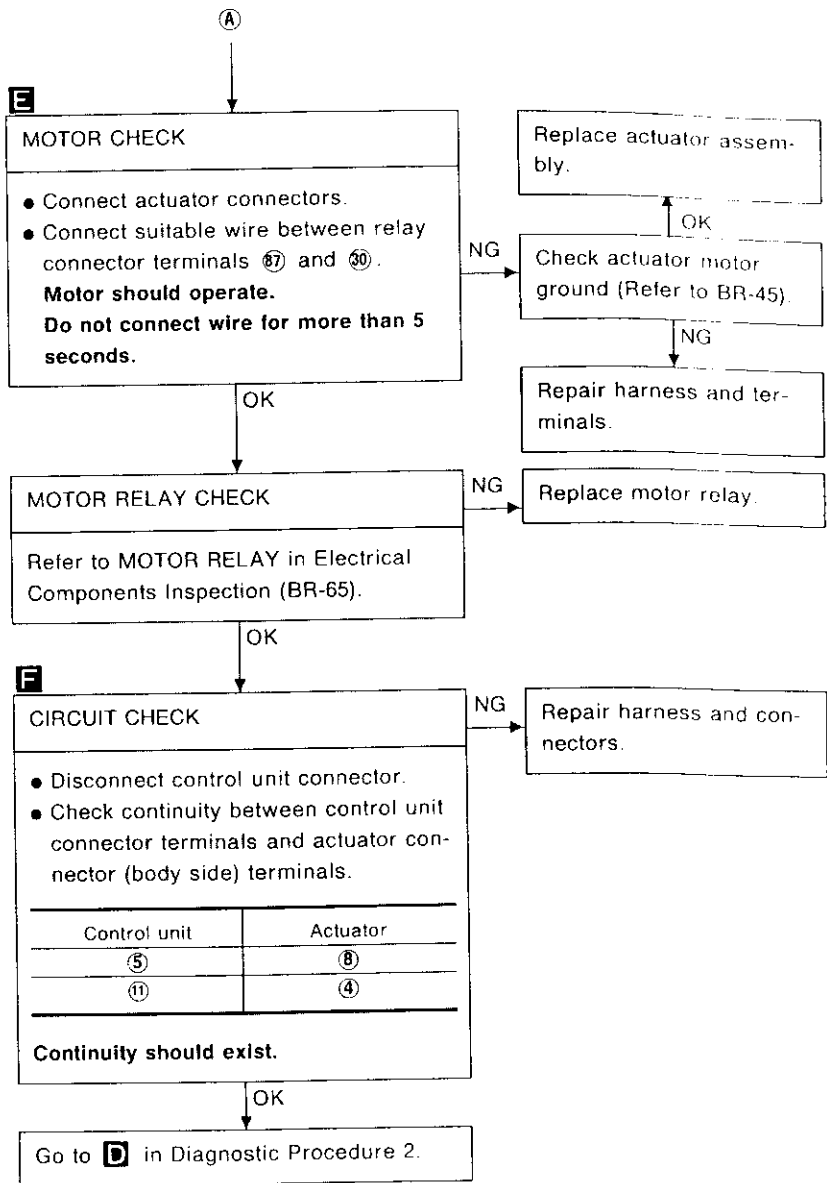
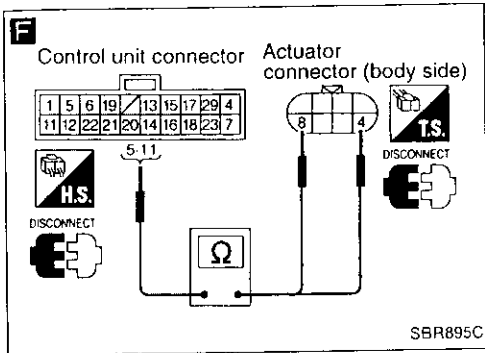
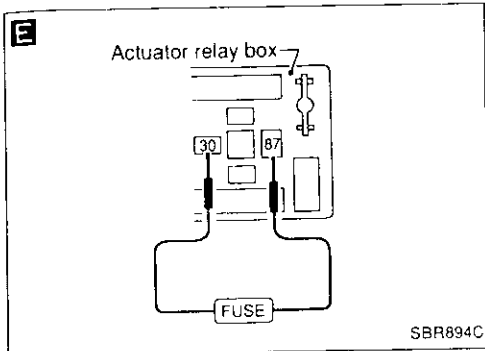

# TROUBLE DIAGNOSES

## Diagnostic Procedure 5 (Cont'd)

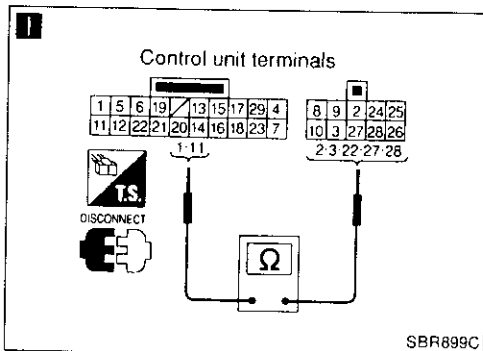
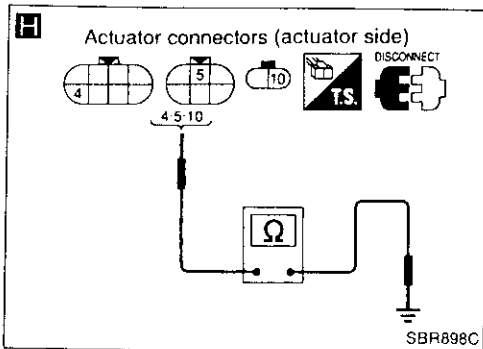
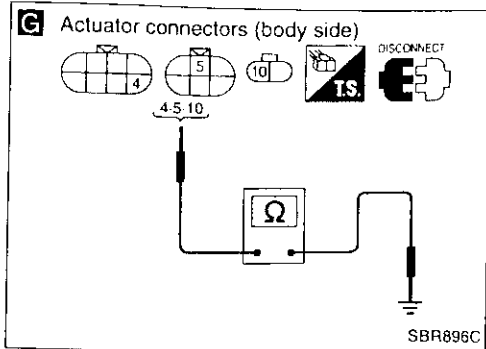

**B**

● Replace fusible link or fuse.  
Is it blown out when it is replaced or ignition switch is turned "ON"?

No → Inspection end

Yes →

**G** MOTOR POWER SUPPLY CIRCUIT

● Disconnect connectors from actuator and control unit.  
● Check continuity between actuator connector (body side) terminals and ground.

Fuse/Fusible link	Terminals
Fusible link <b>L</b>	④ - ground ⑩ - ground
Fuse <b>1</b>	⑤ - ground

Continuity should not exist.

NG → Repair harness and connector.

OK →

**H**

● Remove motor ground.  
● Check continuity between actuator connector (actuator side) terminals and ground.

Fuse/Fusible link	Terminals
Fusible link <b>L</b>	④ - ground ⑩ - ground
Fuse <b>1</b>	⑤ - ground

Continuity should not exist.

NG → Replace actuator assembly.

OK →

**I**

● Check continuity between control unit terminals.

Fuse/Fusible link	Terminals
Fusible link <b>L</b>	①① - ②, ③, ②②, ②⑦, ②⑧
Fuse <b>1</b>	①① - ②, ③, ②②, ②⑦, ②⑧

Continuity should not exist.

NG → Replace control unit.

OK →

Replace actuator assembly.

# TROUBLE DIAGNOSES

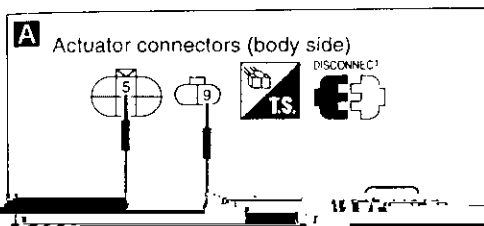

## Diagnostic Procedure 6

**SOLENOID VALVE RELAY**  
(Malfunction code No. 41, 42)

NG

# TROUBLE DIAGNOSES

## Diagnostic Procedure 6 (Cont'd)

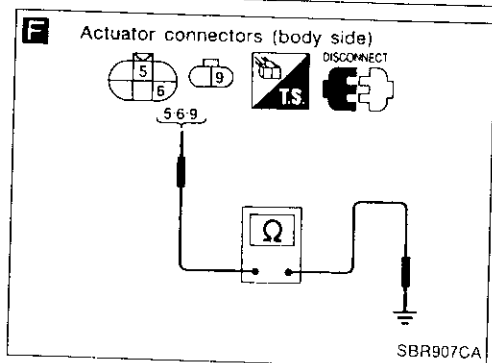
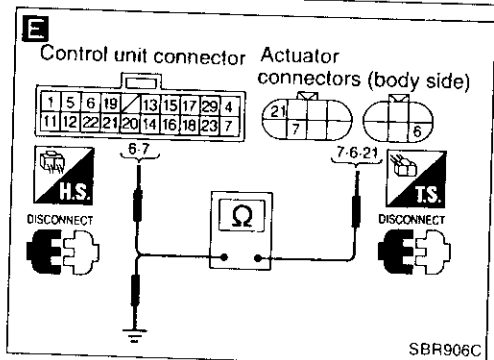
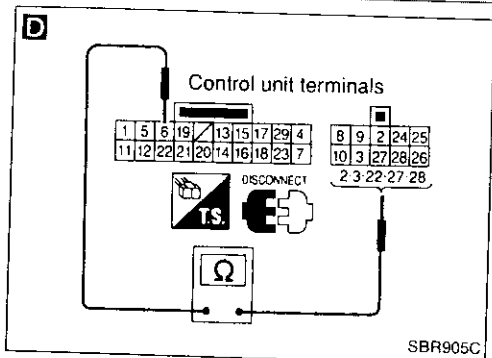
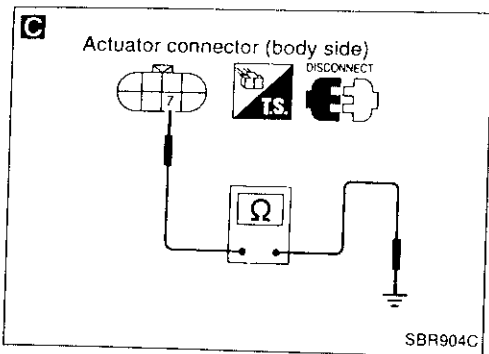

**A**

**C**

- Check continuity between actuator connector (body side) terminal ⑦ and ground.

**Continuity should not exist.**

OK → **C** (See below.)

NG ↓

**D**

- Disconnect control unit connectors.
- Check continuity between control unit terminals (control unit side) ⑥ and ②, ③, ②②, ②⑦, ②⑧.

**Continuity should not exist.**

OK → Repair harness and connectors.

NG ↓

Replace control unit.

**C**

**E**

**CIRCUIT CHECK**

- Disconnect control unit connector.
- Check continuity between control unit connector terminals and actuator connector (body side) terminals.

Control unit	Actuator
⑥	⑦
⑦	⑥
Ground	②①

**Continuity should exist.**

OK

Go to **D** in Diagnostic Procedure 2.

**B**

- Replace fusible link or fuse.

Is it blown out when it is replaced or ignition switch is turned "ON"?

No → Inspection end

Yes ↓

**F**

**ACTUATOR POWER SUPPLY CIRCUIT**

- Disconnect connectors from actuator and control unit.
- Check continuity between actuator connector (body side) terminals and ground.

NG → Repair harness and connector.

Fuse/Fusible link	Terminals
Fusible link [K]	⑥ - ground
Fuse [1]	⑨ - ground
	⑤ - ground

**Continuity should not exist.**

OK

**D**

(Go to next page.)

# TROUBLE DIAGNOSES

## Diagnostic Procedure 6 (Cont'd)

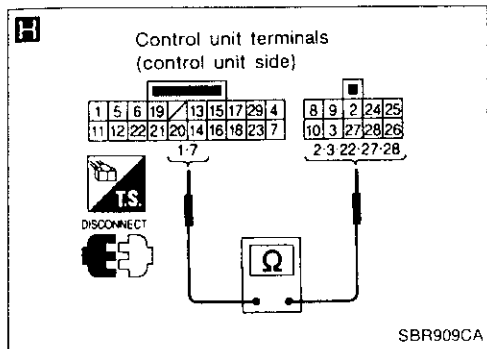
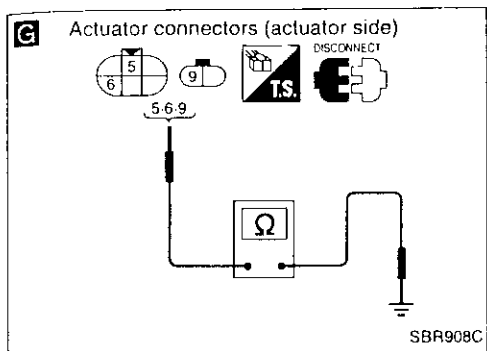

①

**G**

- Check continuity between actuator connector (actuator side) terminals and ground.

Fuse/Fusible link	Terminals
Fusible link <b>K</b>	⑥ - ground ⑨ - ground
Fuse <b>1</b>	⑤ - ground

**Continuity should not exist.**

NG → Replace actuator assembly.

OK

**H**

- Check continuity between control unit terminals (control unit side).

Fuse/Fusible link	Terminals
Fusible link <b>K</b>	⑦ - ②, ③, ②②, ②⑦, ②⑧
Fuse <b>1</b>	① - ②, ③, ②②, ②⑦, ②⑧

**Continuity should not exist.**

NG → Replace control unit.

OK

Replace actuator assembly.

SI  
VIA  
EWA  
LC  
EG  
EE  
CL  
MT  
AT  
PD  
EA  
BA  
BR  
ST  
SS  
BT  
HA  
EL  
IDX

## TROUBLE DIAGNOSES

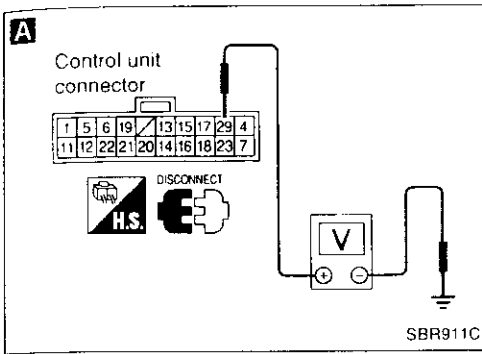

### Diagnostic Procedure 8

#### MEMORY VOLT STOP

- Disconnect control unit connectors. Check terminals for damage or loose connection. Then reconnect connectors.
  - Turn ignition switch ON and OFF more than two times
  - Carry out self-diagnosis again.
- Does warning lamp activate again?**

No → Inspection end

Yes

- A**
- CONTROL UNIT POWER SUPPLY**
- Disconnect control unit connectors.
  - Check voltage between connector for

NG → Check harness and connectors between battery and control unit connector terminal 60 or 75A

# TROUBLE DIAGNOSES

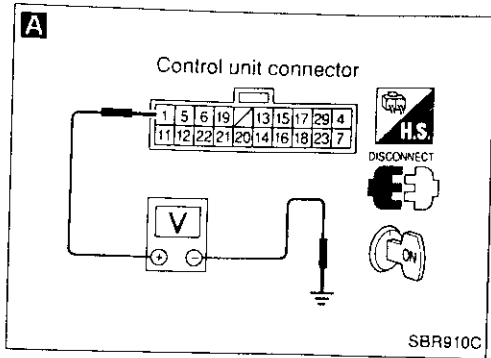

## Diagnostic Procedure 7

### POWER SUPPLY

(Malfunction code No. 47, 48)

- Disconnect control unit connectors. Check terminals for damage or connection. Then reconnect connectors.
  - Carry out self-diagnosis again.
- Does warning lamp activate again?**

No

Inspection end

Yes

**A**

#### CONTROL UNIT POWER SUPPLY

- Disconnect control unit connectors.
  - Check voltage between connector terminal ① and ground when ignition switch is turned ON.
- Battery voltage should exist.**

NG

Check harness and connectors between battery and control unit connector terminal ①, 10A fuse ① or battery. For fuse layout, refer to POWER SUPPLY ROUTING in EL section.

OK

#### CONTROL UNIT GROUND CIRCUIT

Refer to CONTROL UNIT GROUND in Ground Circuit Check (BR-45).

NG

Repair harness and connectors.

OK

Replace control unit.



# TROUBLE DIAGNOSES

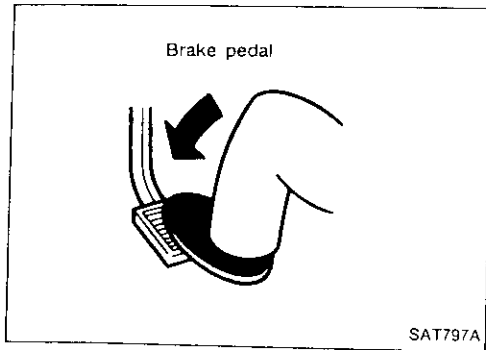

## Diagnostic Procedure 9

### SYMPTOM: Pedal vibration and noise

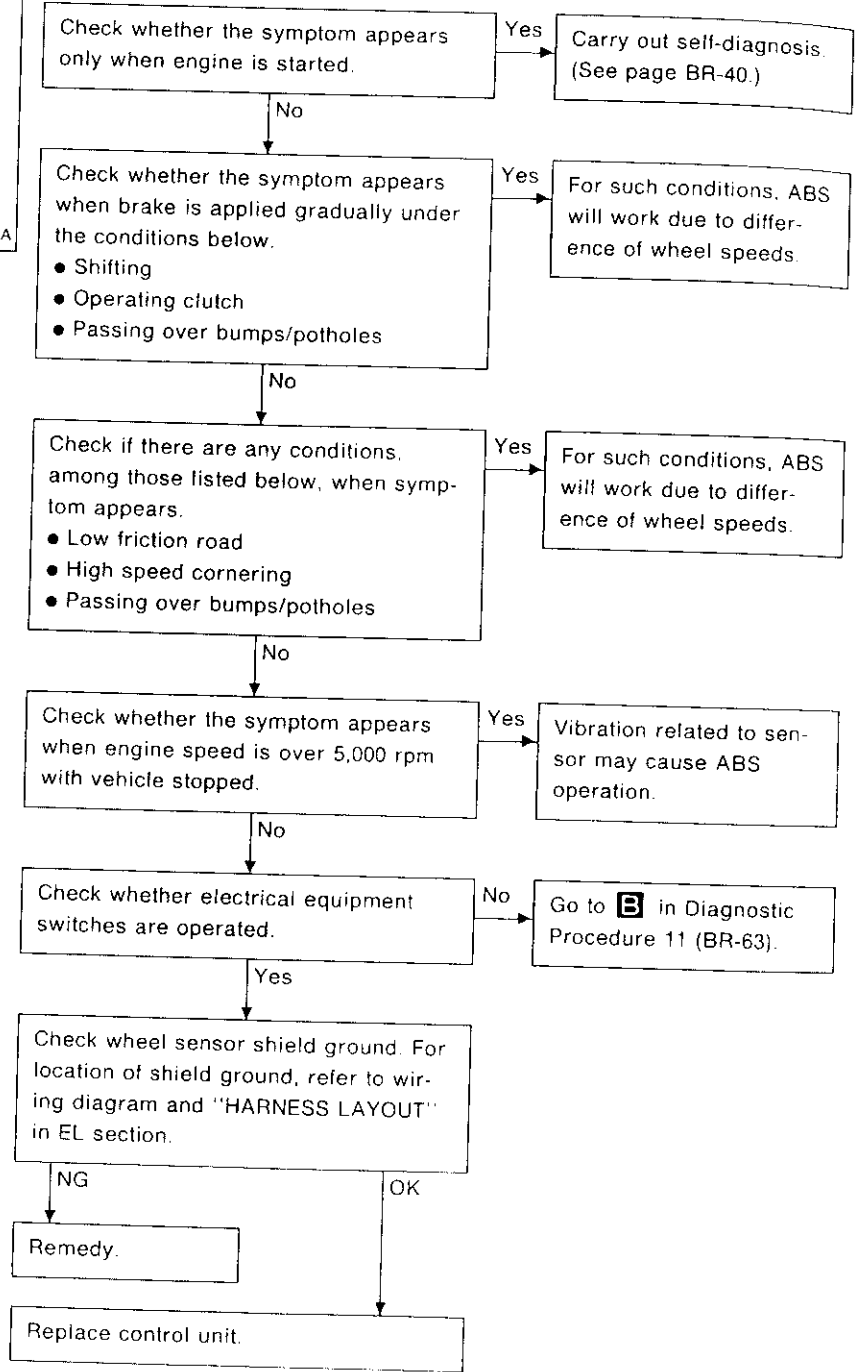

# TROUBLE DIAGNOSES

## Diagnostic Procedure 10

**SYMPTOM: Long stopping distance**

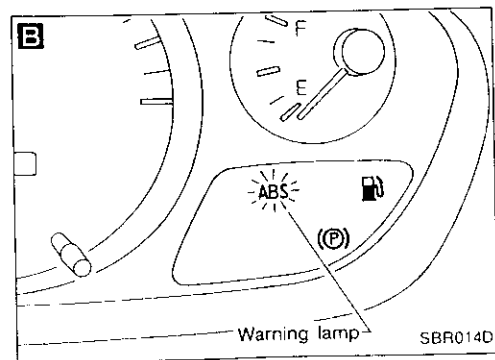
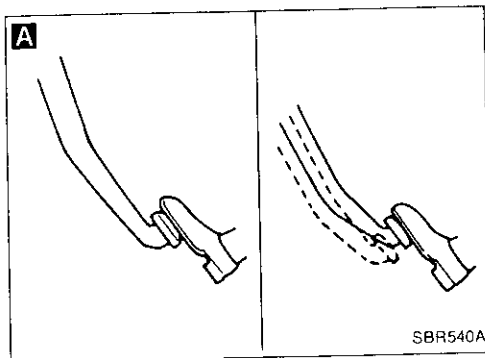
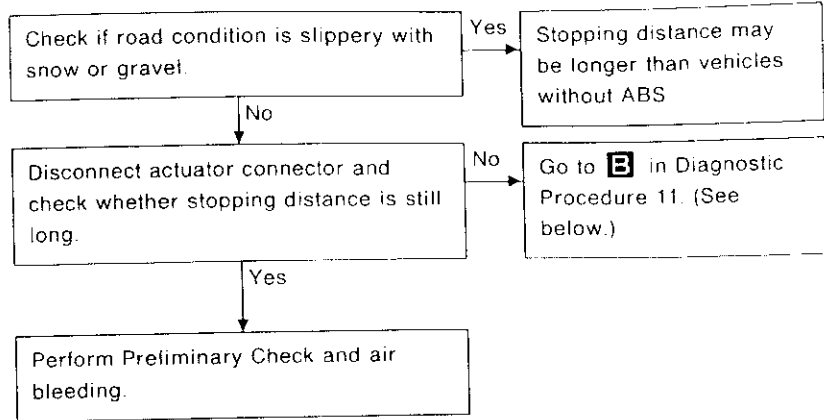

## Diagnostic Procedure 11

**SYMPTOM: Unexpected pedal action**

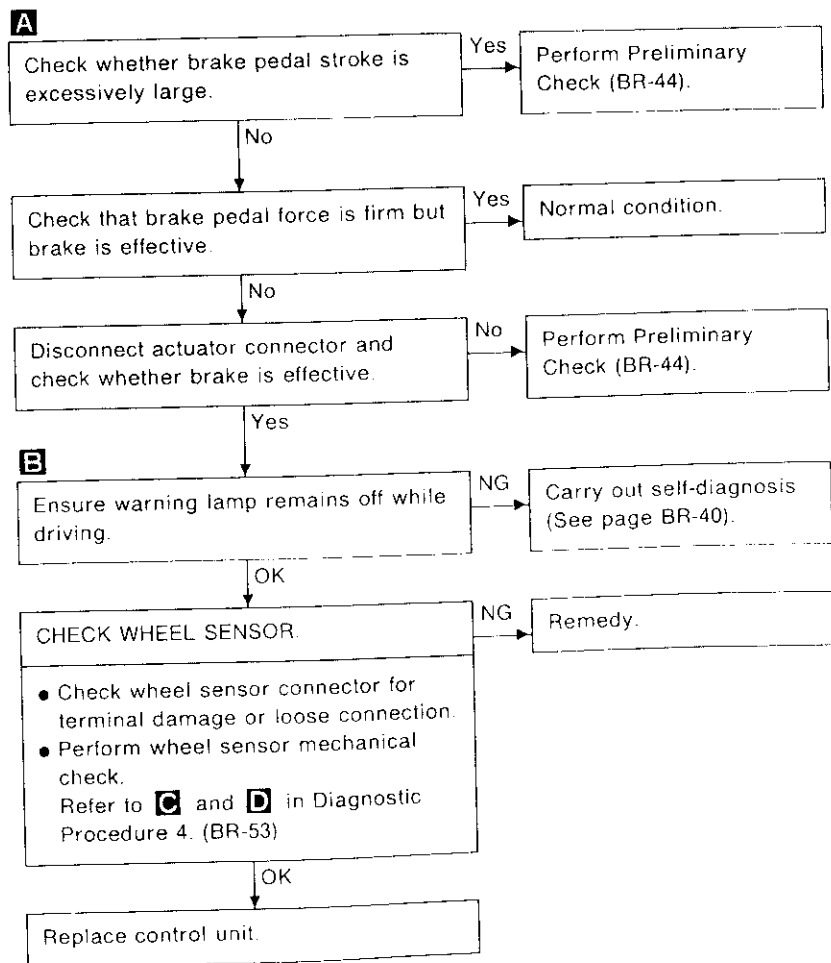

## TROUBLE DIAGNOSES

### Diagnostic Procedure 12

**SYMPTOM: ABS does not work.**

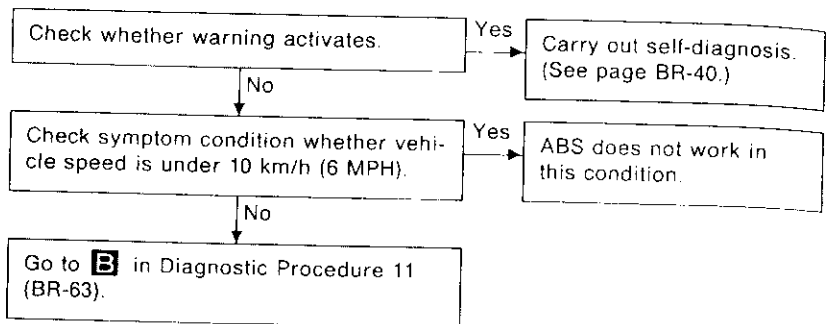

### Diagnostic Procedure 13

**SYMPTOM: ABS works frequently.**

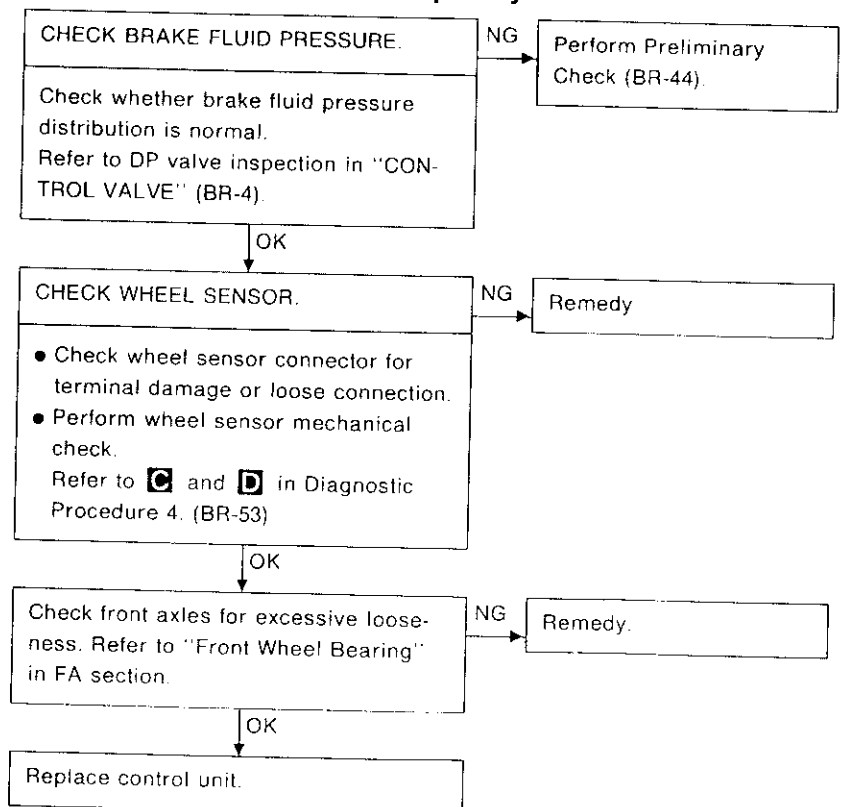

## TROUBLE DIAGNOSES

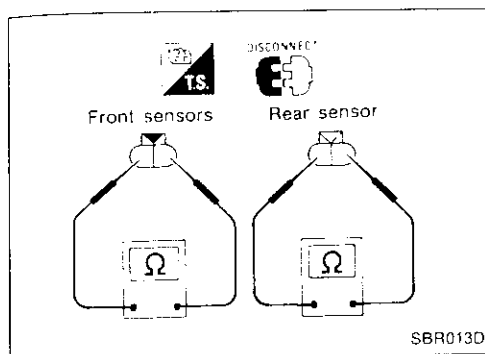

### Electrical Components Inspection

#### WHEEL SENSOR

Check resistance for each sensor.

**Resistance: 0.6 - 3.3 kΩ**

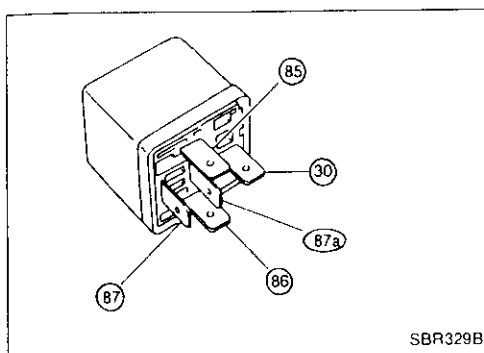

#### ACTUATOR MOTOR RELAY AND SOLENOID VALVE RELAY

	Solenoid valve relay	Actuator motor relay solenoid valve relay
Condition	Continuity existence between terminals 30 and 87a	Continuity existence between terminals 30 and 87
Battery voltage not applied between termi- nals 85 and 86.	Yes	No
Battery voltage applied between terminals 85 and 86.	No	Yes

BR



# STEERING SYSTEM

## SECTION **ST**

### CONTENTS

<b>PRECAUTIONS AND PREPARATION</b> .....	2	Disassembly and Assembly .....	12
Precautions .....	2	Inspection .....	13
Special Service Tools .....	2	<b>POWER STEERING GEAR AND LINKAGE (Model</b>	
Commercial Service Tools .....	3	<b>PR24AC)</b> .....	14
<b>ON-VEHICLE SERVICE</b> .....	5	Removal and Installation .....	14
Checking Steering Wheel Play .....	5	Disassembly and Assembly .....	16
Checking Neutral Position on Steering Wheel .....	5	Disassembly .....	17
Front Wheel Turning Angle .....	5	Inspection .....	17
Checking Gear Housing Movement .....	6	Assembly .....	18
Adjusting Rack Retainer .....	6	Adjustment .....	22
Checking and Adjusting Drive Belts (For		<b>POWER STEERING OIL PUMP</b> .....	24
power steering) .....	6	Disassembly and Assembly .....	24
Checking Fluid Level .....	6	Pre-disassembly Inspection .....	24
Checking Fluid Leakage .....	6	Disassembly .....	25
Bleeding Hydraulic System .....	7	Inspection .....	25
Checking Steering Wheel Turning Force		Assembly .....	26
(For power steering) .....	7	<b>SERVICE DATA AND SPECIFICATIONS (SDS)</b> .....	27
Checking Hydraulic System .....	8	General Specifications .....	27
<b>STEERING WHEEL AND STEERING COLUMN</b> .....	9	Inspection and Adjustment .....	27
Removal and Installation .....	9		

ST

## PRECAUTIONS AND PREPARATION

### Precautions

#### SUPPLEMENTAL RESTRAINT SYSTEM (SRS) "AIR BAG" AND "SEAT BELT PRE-TENSIONER"

The Supplemental Restraint System "Air Bag" and "Seat belt pre-tensioner", used along with a seat belt, help to reduce the risk or severity of injury to the driver and front passenger in a frontal collision. The Supplemental Restraint System consists of air bag modules (located in the center of the steering wheel and on the instrument panel on the passenger side), seat belt pre-tensioner, a diagnosis sensor unit, warning lamp, wiring harness and spiral cable. Information necessary to service the system safely is included in the **RS section** of this Service Manual.

**WARNING:**

- To avoid rendering the SRS inoperative, which could increase the risk of personal injury or death in the event of a collision which would result in air bag inflation, all maintenance must be performed by an authorized NISSAN dealer.
- Improper maintenance, including incorrect removal and installation of the SRS, can lead to personal injury caused by unintentional activation of the system.
- All SRS electrical wiring harnesses and connectors are covered with yellow outer insulation. Do not use electrical test equipment on any circuit related to the SRS.

### STEERING SYSTEM

- Before disassembly, thoroughly clean the outside of the unit.
- Disassembly should be done in a clean work area. It is important to prevent the internal parts from becoming contaminated by dirt or other foreign matter.
- Place disassembled parts in order, on a parts rack, for easier and proper assembly.
- Use nylon cloths or paper towels to clean the parts; common shop rags can leave lint that might interfere with their operation.
- Before inspection or reassembly, carefully clean all parts with a general purpose, non-flammable solvent.
- Before assembly, apply a coat of recommended ATF\* to hydraulic parts. Vaseline may be applied to O-rings and seals. Do not use any grease.
- Replace all gaskets, seals and O-rings. Avoid damaging O-rings, seals and gaskets during installation. Perform functional tests whenever designated.

\*: Automatic transmission fluid

### Special Service Tools

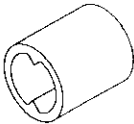
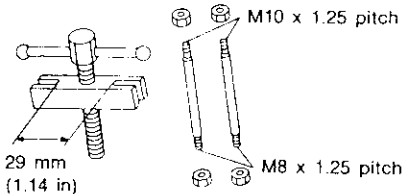
Tool number Tool name	Description
KV48100700 Torque adapter	<div style="text-align: right;">Measuring pinion rotating torque</div>  <p style="text-align: center;">NT169</p>
ST27180001 Steering wheel puller	<div style="text-align: right;">Removing and installing steering wheel</div>  <p style="text-align: center;">NT544</p>

## PRECAUTIONS AND PREPARATION

### Special Service Tools (Cont'd)

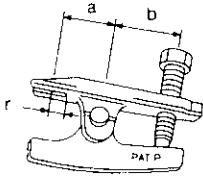
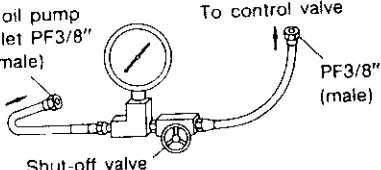
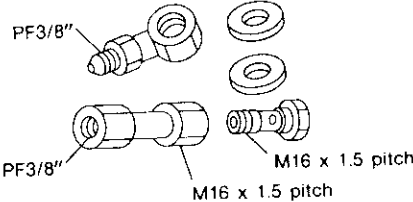
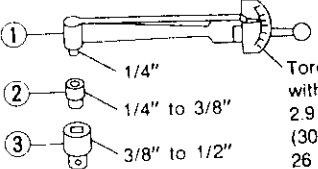
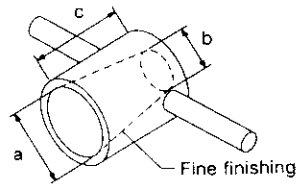
Tool number Tool name	Description	
HT72520000 Ball joint remover	 <p style="text-align: right;">a: 33 mm (1.30 in) b: 50 mm (1.97 in) r: R11.5 mm (0.453 in)</p>	Removing ball joint
ST27091000 Pressure gauge	 <p style="text-align: center;">Shut-off valve</p>	Measuring oil pressure
KV48102500 Pressure gauge adapter		Measuring oil pressure
ST3127S000 ① GG91030000 Torque wrench ② HT62940000 Socket adapter ③ HT62900000 Socket adapter	 <p style="text-align: right;">Torque wrench with range of 2.9 N·m (30 kg·cm, 26 in·lb)</p>	Measuring turning torque
KV48104400 Rack seal ring reformer	 <p style="text-align: right;">a: 50 mm (1.97 in) dia. b: 36 mm (1.42 in) dia. c: 100 mm (3.94 in)</p>	Reforming teflon ring

### Commercial Service Tools

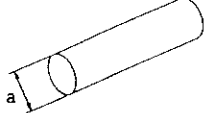
Tool name	Description	
Rear oil seal drift	 <p style="text-align: right;">a: 28 mm (1.10 in) dia.</p>	Installing rear oil seal



## ON-VEHICLE SERVICE

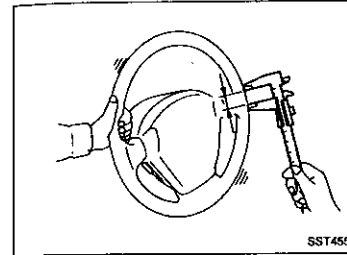

### Checking Steering Wheel Play

1. With wheels in a straight-ahead position, check steering wheel play.

#### Steering wheel play:

35 mm (1.38 in) or less

2. If it is not within specification, check the following for loose or worn components.

Steering gear assembly  
Steering column  
Front suspension and axle

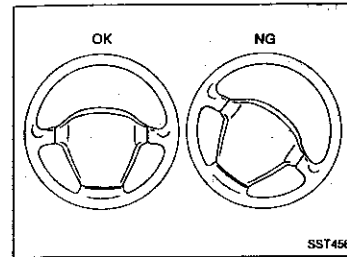

### Checking Neutral Position on Steering Wheel

#### Pre-checking

- Make sure that wheel alignment is correct.

#### Wheel alignment:

Refer to SDS in FA section.

- Verify that the steering gear is centered before removing the steering wheel.

#### Checking

- Check that the steering wheel is in the neutral position when driving straight ahead.
- If it is not in the neutral position, remove the steering wheel and reinstall it correctly.
- If the neutral position is between two teeth, loosen tie-rod lock nuts. Turn the tie-rods by the same amount in opposite directions on both left and right sides.

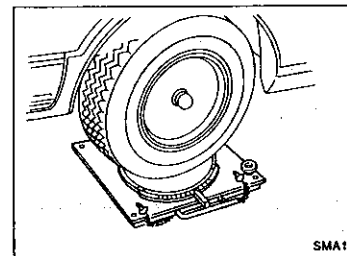

### Front Wheel Turning Angle

- Rotate steering wheel all the way right and left; measure turning angle.

#### Turning angle of full turns:

Refer to SDS in FA section.

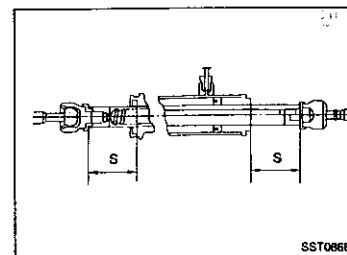

- If it is not within specification, check rack stroke.

#### Measured length "S":

Refer to SDS (ST-27).

## ON-VEHICLE SERVICE



### Checking Gear Housing Movement

1. Check the movement of steering gear housing during stationary steering on a dry paved surface.
  - Apply a force of 49 N (5 kg, 11 lb) to steering wheel to check the gear housing movement.

Turn off ignition key while checking.  
**Movement of gear housing:**  
±2 mm (±0.08 in) or less

2. If movement exceeds the limit, replace mount insulator after confirming proper installation of gear housing clamps.

### Adjusting Rack Retainer

- Perform this driving test on a flat road.
1. Check whether vehicle moves in a straight line when steering wheel is released.
  2. Check whether steering wheel returns to neutral position when steering wheel is released from a slightly turned (approx. 20°) position.
- If any abnormality is found, correct it by resetting adjusting screw.



### Checking and Adjusting Drive Belts (For power steering)

Refer to Drive Belt Inspection in MA section.

### Checking Fluid Level

Check fluid level with dipstick on reservoir cap.  
Use "HOT" range for fluid temperatures of 50 to 80°C (122 to 176°F).

Use "COLD" range for fluid temperatures of 0 to 30°C (32 to 86°F).

#### CAUTION:

- Do not overfill.
- Recommended fluid is Automatic Transmission Fluid "DEXRON™" type or equivalent.

### Checking Fluid Leakage

Check the lines for improper attachment and for leaks, cracks, damage, loose connections, chafing or deterioration

1. Run engine at idle speed or 1,000 rpm.  
**Make sure temperature of fluid in oil tank rises to 60 to 80°C (140 to 176°F).**
2. Turn steering wheel right-to-left several times.
3. Hold steering wheel at each "lock" position for five seconds and carefully check for fluid leakage

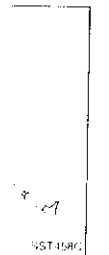

ST-6

## ON-VEHICLE SERVICE

### Checking Fluid Leakage (Cont'd)

#### CAUTION:

Do not hold the steering wheel in a locked position for more than 15 seconds.

4. If fluid leakage at connectors is noticed, loosen flare nut and then retighten.

Do not overtighten connector as this can damage O-ring, washer and connector.

### Bleeding Hydraulic System

1. Raise front end of vehicle until wheels clear ground.
  2. Add fluid into oil tank to specified level. Then, quickly turn steering wheel fully to right and left and tightly touch steering stoppers.  
Repeat steering wheel operation until fluid level no longer decreases.
  3. Start engine.  
Repeat step 2 above.
    - Incomplete air bleeding will cause the following to occur. When this happens, bleed air again.
      - a. Air bubbles in reservoir tank
      - b. Clicking noise in oil pump
      - c. Excessive buzzing in oil pump
- Fluid noise may occur in the valve or oil pump. This is common when the vehicle is stationary or while turning the steering wheel slowly. This does not affect the performance or durability of the system

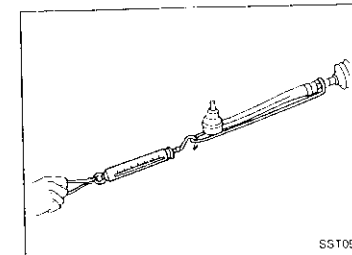
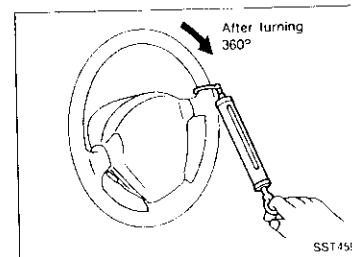

### Checking Steering Wheel Turning Force (For power steering)

1. Park vehicle on a level, dry surface and set parking brake.
2. Start engine.
3. Bring power steering fluid up to adequate operating temperature. [Make sure temperature of fluid is approximately 60 to 80°C (140 to 176°F).]

Tires need to be inflated to normal pressure.

4. Check steering wheel turning force when steering wheel has been turned 360° from the neutral position.

**Steering wheel turning force:**

**39 N (4 kg, 9 lb) or less**

5. If steering wheel turning force is out of specification, check rack sliding force.
  - a. Disconnect steering column lower joint and knuckle arms from the gear.
  - b. Start and run engine at idle to make sure steering fluid has reached normal operating temperature.
  - c. Pull tie-rod slowly to move it from neutral position to ±11.5 mm (+0.453 in) at speed of 3.5 mm (0.138 in)/s. Check that rack sliding force is within specification.

ST-7

## ON-VEHICLE SERVICE

### Checking Steering Wheel Turning Force (For power steering) (Cont'd)

**Average rack sliding force:**  
186 - 245 N (19 - 25 kg, 42 - 55 lb)  
**Maximum force deviation:**  
98 N (10 kg, 22 lb)

- If rack sliding force is not within specification, overhaul steering gear assembly.

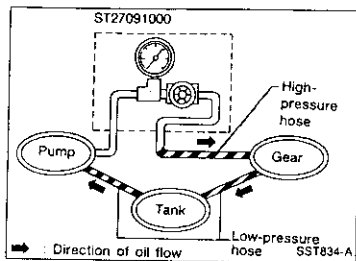
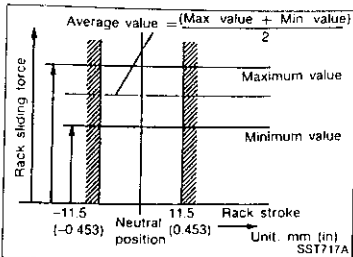

### Checking Hydraulic System

Before starting, check belt tension, driving pulley and tire pressure.

- Set Tool. Open shut-off valve. Then bleed air. (See "Bleeding Hydraulic System", ST-7.)
- Run engine.

Make sure temperature of fluid in tank rises to 60 to 80°C (140 to 176°F).

#### WARNING:

Warm up engine with shut-off valve fully opened. If engine is started with shut-off valve closed, fluid pressure in oil pump increases to maximum. This will raise oil temperature abnormally.

- Check pressure with steering wheel fully turned to left and right positions with engine idling at 1,000 rpm.

#### CAUTION:

Do not hold the steering wheel in a locked position for more than 15 seconds.

#### Oil pump maximum pressure:

8,630 - 9,219 kPa (86.3 - 92.2 bar, 88 - 94 kg/cm<sup>2</sup>,  
1,251 - 1,337 psi)

- If oil pressure is below the standard pressure, slowly close shut-off valve and check pressure.
- When pressure reaches standard pressure, gear is damaged.
- When pressure remains below standard pressure, pump is damaged.

#### CAUTION:

Do not close shut-off valve for more than 15 seconds.

- If oil pressure is higher than standard pressure, check oil pump flow control valve.
- After checking hydraulic system, remove Tool and add fluid as necessary. Then completely bleed air out of system.

ST-8

## STEERING WHEEL AND STEERING COLUMN

### Removal and Installation

SEC. 488-484

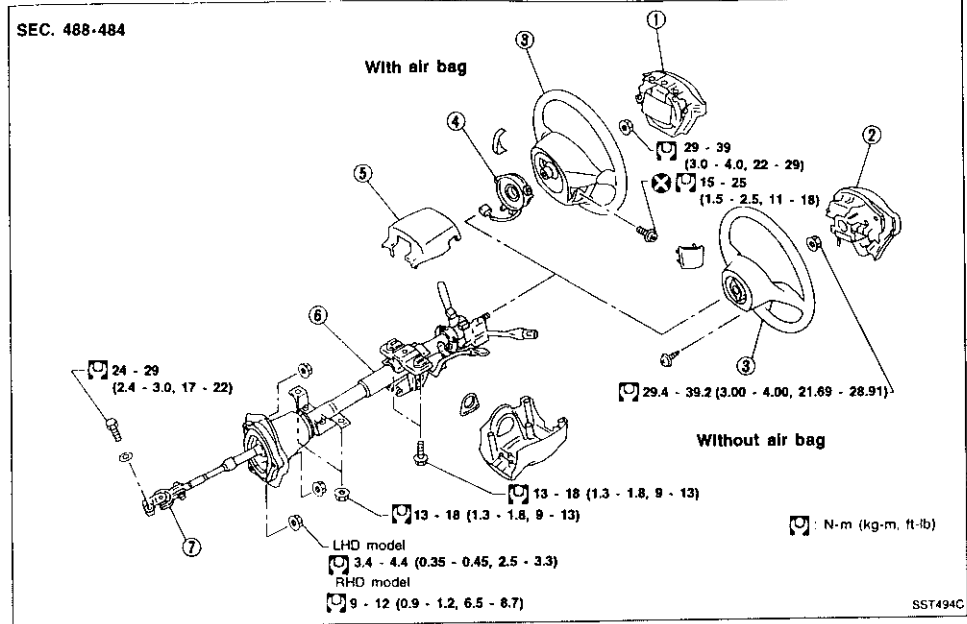

- Air bag module
- Horn pad
- Steering wheel

- Spiral cable
- Column cover

- Steering column assembly
- Lower joint

#### CAUTION:

- The rotation of the spiral cable (SRS "Air bag" component part) is limited. If the steering gear must be removed, set the front wheels in the straight-ahead direction. Do not rotate the steering column while the steering gear is removed.
- Remove the steering wheel before removing the steering lower joint to avoid damaging the SRS spiral cable.

### STEERING WHEEL

#### — With air bag type —

- Remove air bag module and spiral cable. Refer to "Removal — Air Bag Module and Spiral Cable", "SUPPLEMENTAL RESTRAINT SYSTEM" in RS section.

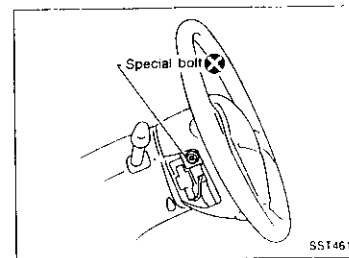

ST-9

## STEERING WHEEL AND STEERING COLUMN

### Removal and Installation (Cont'd)

- Align spiral cable correctly when installing steering wheel.
  - Set the front wheels in the straight-ahead position.
  - Make sure that the spiral cable is in the neutral position. The neutral position is detected by turning left 2.5 revolutions from the right end position. Align the two marks (X).

#### CAUTION:

The spiral cable may snap due to steering operation if the cable is installed in an improper position. Also, with the steering linkage disconnected, the cable may snap by turning the steering wheel beyond the limited number of turns. (The spiral cable can be turned up to 2.5 turns from the neutral position to both the right and left.)

#### — Without air bag type —

- Remove horn pad. Insert a crosshead screwdriver into hole on lower side of spoke and remove screw. Lift horn pad off by hand.
- Remove steering wheel with Tool.
- When installing steering wheel, lubricate with multi-purpose grease. Apply grease to entire surface of turn signal cancel pins and horn contact slip rings.

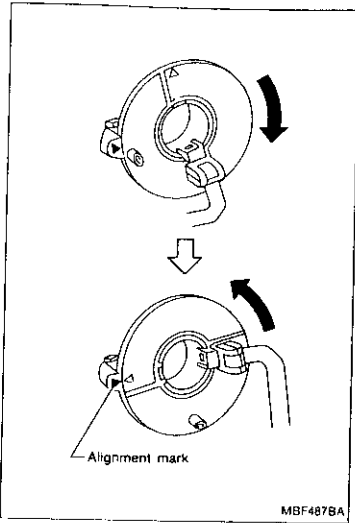

MBF487BA

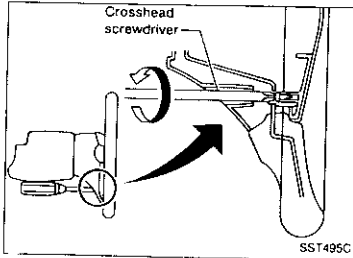

SST495C

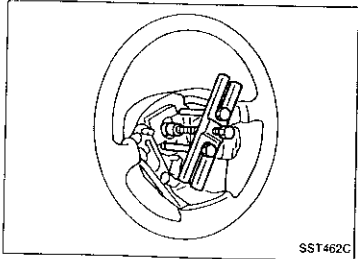

SST462C

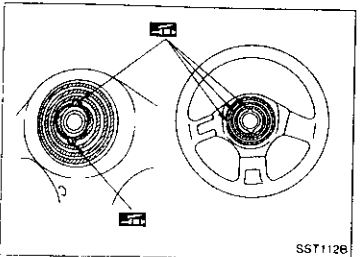

SST1126

## STEERING WHEEL AND STEERING COLUMN

### Removal and Installation (Cont'd)

#### STEERING COLUMN

- When installing steering column, fingertighten all lower bracket and clamp retaining bolts; then tighten them securely. Do not apply undue stress to steering column.
- When attaching coupling joint, be sure tightening bolt faces cutout portion.

- Align slit of lower joint with projection on dust cover. Insert joint until it stops.

#### CAUTION:

After installation, turn steering wheel to make sure it moves smoothly. Ensure the number of turns are the same from the straight forward position to left and right locks. Be sure that the steering wheel is in a neutral position when driving straight ahead.

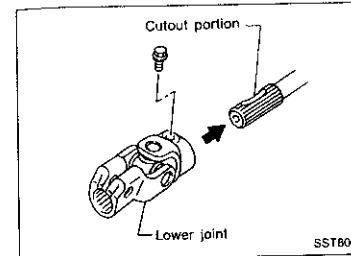

SST800A

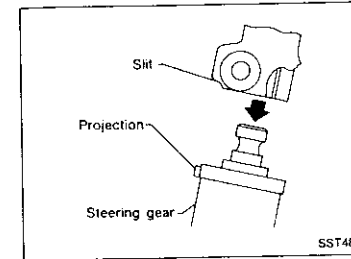

SST489C

## STEERING WHEEL AND STEERING COLUMN

### Disassembly and Assembly (Cont'd)

- Steering lock
  - a. Break self-shear type screws with a drill or other appropriate tool.
  - b. Install new self-shear type screws and then cut off self-shear type screw heads.

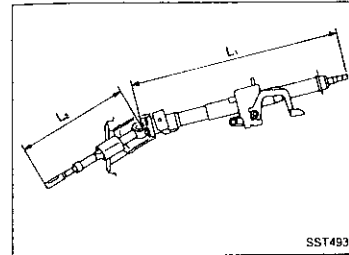
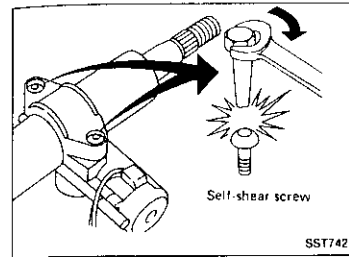

### Inspection

- When steering wheel does not turn smoothly, check the steering column as follows and replace damaged parts.
  - a. Check column bearings for damage or unevenness. Lubricate with recommended multi-purpose grease or replace steering column as an assembly, if necessary.
  - b. Check steering column lower shaft for deformation or breakage. Replace if necessary.
- When the vehicle comes into a light collision, check length "L<sub>1</sub>" and "L<sub>2</sub>".

#### Steering column length "L<sub>1</sub>":

LHD model 630.7 mm (24.83 in)

RHD model 610.0 mm (24.02 in)

#### Steering column lower shaft length "L<sub>2</sub>":

LHD model 323.7 mm (12.74 in)

RHD model 341.0 mm (13.43 in)

If out of the specifications, replace steering column as an assembly.

### ● Tilt mechanism

After installing steering column, check tilt mechanism operation.

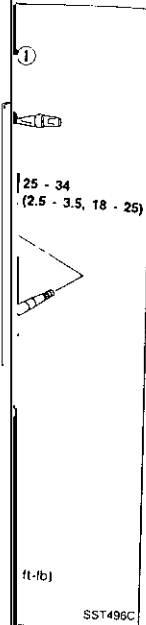
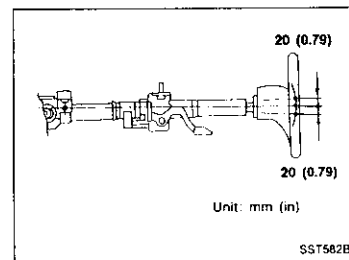

assembly

lock insulator

shaft

steering lock

when the nut

# POWER STEERING GEAR AND LINKAGE (Model PR24AC)

## Removal and Installation

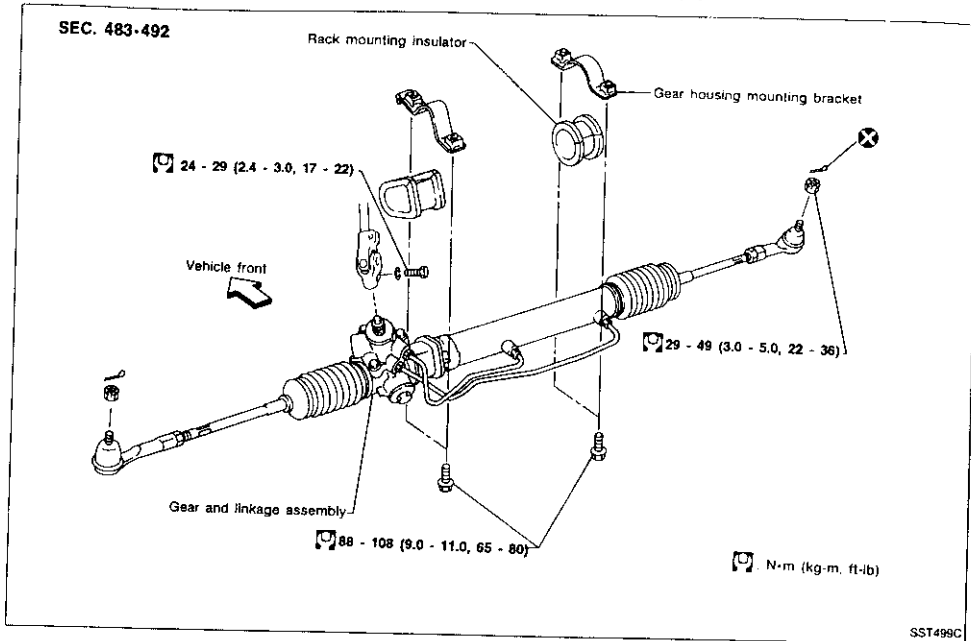

### CAUTION:

- The rotation of the spiral cable (SRS "Air bag" component part) is limited. If the steering gear must be removed, set the front wheels in the straight-ahead direction. Do not rotate the steering column while the steering gear is removed.
- Remove the steering wheel before removing the steering lower joint to avoid damaging the SRS spiral cable.
- Detach tie-rod outer sockets from knuckle arms with Tool.

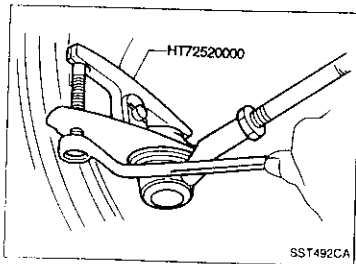

# POWER STEERING GEAR AND LINKAGE (Model PR24AC)

## Removal and Installation (Cont'd)

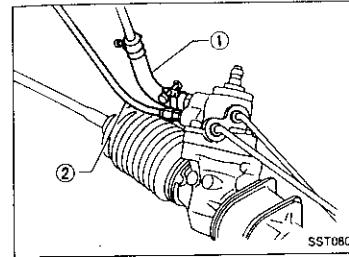

- Install pipe connector.
- Observe specified tightening torque when tightening high-pressure and low-pressure pipe connectors. Excessive tightening can damage threads or damaged connector O-ring.

### Connector tightening torque:

Low-pressure side "1"

27 - 39 N·m (2.8 - 4.0 kg·m, 20 - 29 ft·lb)

High-pressure side "2"

15 - 25 N·m (1.5 - 2.5 kg·m, 11 - 18 ft·lb)

- The O-ring in low-pressure pipe connector is larger than that in high-pressure connector. Take care to install the proper O-ring.

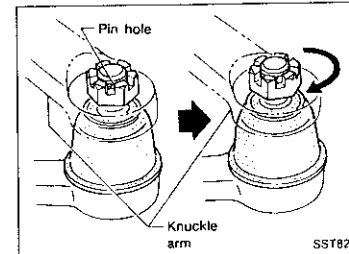

- Initially, tighten nut on tie-rod outer socket and knuckle arm to 29 to 39 N·m (3 to 4 kg·m, 22 to 29 ft·lb). Then tighten further to align nut groove with first pin hole so that cotter pin can be installed.

### CAUTION:

Tightening torque must not exceed 49 N·m (5 kg·m, 36 ft·lb).

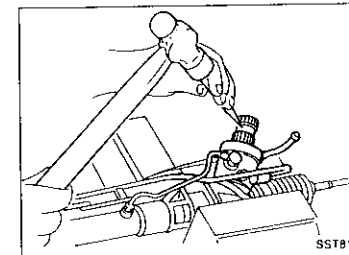

- Before removing lower joint from gear, set gear in neutral (wheels in straight-ahead position). After removing lower joint, put matching mark on pinion shaft and pinion housing to record neutral position.
- To install, set left and right dust boots to equal deflection. Attach lower joint by aligning matching marks of pinion shaft and pinion housing.

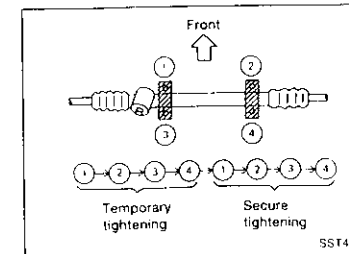

- Tighten gear housing mounting bracket bolts in the order shown.

### Temporary tightening torque:

78 N·m (8.0 kg·m, 58 ft·lb)

### Secure tightening torque:

88 - 108 N·m (9.0 - 11.0 kg·m, 65 - 80 ft·lb)

# POWER STEERING GEAR AND LINKAGE (Model PR24AC)

## Disassembly and Assembly

SEC. 483-492

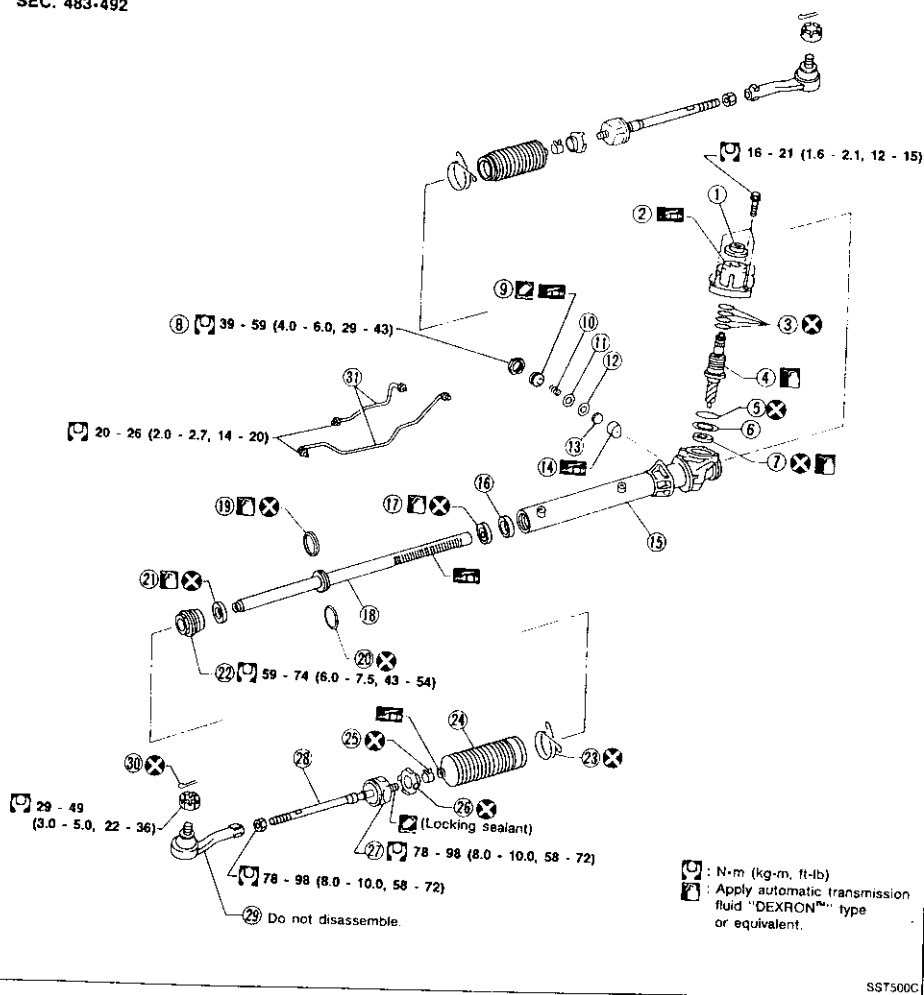

- |                         |                         |                        |
|-------------------------|-------------------------|------------------------|
| ① Rear housing cover    | ⑫ Washer                | ⑳ End cover assembly   |
| ② Rear housing assembly | ⑬ Spring seat           | ㉑ Boot clamp           |
| ③ Pinion seal ring      | ⑭ Retainer              | ㉒ Dust boot            |
| ④ Pinion assembly       | ⑮ Gear housing assembly | ㉓ Boot band            |
| ⑤ O-ring                | ⑯ Center bushing        | ㉔ Lock plate           |
| ⑥ Shim                  | ⑰ Rack oil seal         | ㉕ Tie-rod              |
| ⑦ Pinion oil seal       | ⑱ Rack assembly         | ㉖ Tie-rod inner socket |
| ⑧ Lock nut              | ⑲ Rack seal ring        | ㉗ Tie-rod outer socket |
| ⑨ Adjusting screw       | ㉘ O-ring                | ㉙ Cotter pin           |
| ⑩ Spring                | ㉚ Rack oil seal         | ㉛ Gear housing tube    |
| ⑪ Spring disc           |                         |                        |

ST-16

# POWER STEERING GEAR AND LINKAGE (Model PR24AC)

## Disassembly

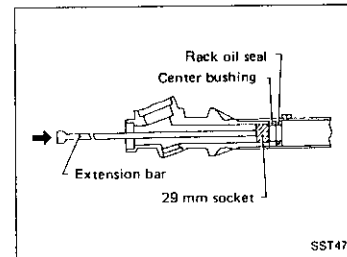
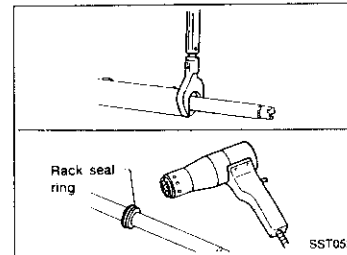
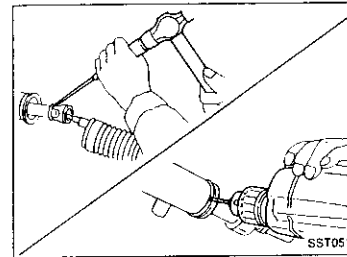
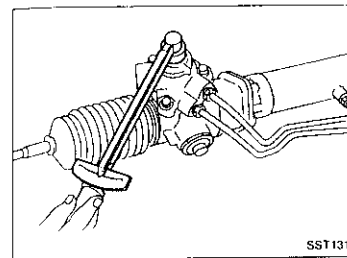

- Prior to disassembling, measure pinion rotating torque. Record the pinion rotating torque as a reference.
  - Before measuring, disconnect cylinder tube and drain fluid.
  - Use soft jaws when holding steering gear housing. Handle gear housing carefully, as it is made of aluminum. Do not grip cylinder in a vise.
- Remove pinion gear.
  - Be careful not to damage pinion gear when removing pinion seal ring.
- Remove tie-rod outer sockets and boots.
- Loosen tie-rod inner socket by prying up staked portion, and remove socket.
- Remove retainer.
- Remove pinion assembly.
- Use a 2 to 2.5 mm (0.079 to 0.098 in) diameter drill to completely remove staked portion of gear housing end.

- Remove gear housing end cover assembly with Tool.
- Draw out rack assembly.
  - Using a heat gun, heat rack seal to approximately 40°C (104°F).
  - Remove rack seal ring.
  - Be careful not to damage rack.

- Remove center bushing and rack oil seal using tape wrapped socket and extension bar.
  - Do not scratch inner surfaces of pinion housing.

## Inspection

Thoroughly clean all parts in cleaning solvent or automatic transmission fluid "DEXRON" type or equivalent. Blow dry with compressed air, if available.

## BOOT

Check condition of boot. If cracked excessively, replace it.

## RACK

Thoroughly examine rack gear. If damaged, cracked or worn, replace it.

ST-17

## Model PR24AC

1 gear. If pinion gear is replaced, replace it. Inspect rack teeth. Ensure that balls, rollers, and pins are not bent, pitted or worn. Replace if necessary.

Check rack for scratches or other damage.

### SOCKETS

Apply force.

Check joints swinging force "A":

Check torque.

Check joint torque "B":

Check play.

Check joints axial end play "C":

Check rack. If cracked excessively, replace.

Position rack seal ring to approximately 2 mm (0.08 in) from rack. Push it onto rack.

Push ring securely onto rack. Check gear side.

## POWER STEERING GEAR AND LINKAGE (Model PR24AC)

### Assembly (Cont'd)

3. Insert rack oil seal.

- Place plastic film into rack oil seal to prevent damage by rack teeth.
- Always remove plastic film after rack oil seal is positioned properly.
- Make sure lips of rack oil seal face each other.

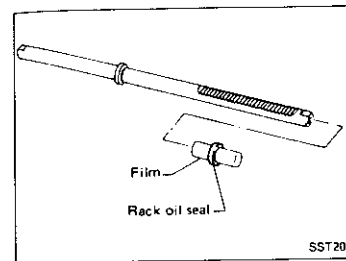

4. Install center bushing and rack oil seal with rack assembly.

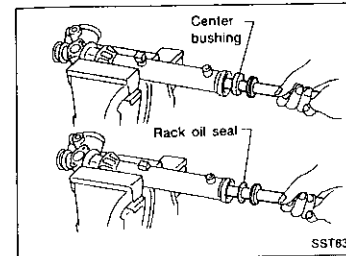

5. Insert rack oil seal and end cover assembly to rack. Then tighten end cover assembly.

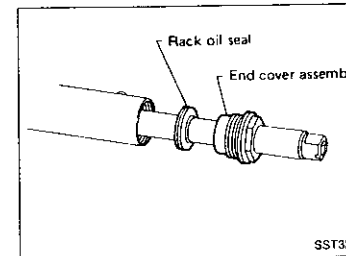

6. Fasten cylinder end cover assembly to gear housing by staking.

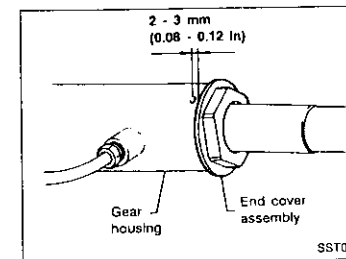

7. Set rack gear in the neutral position. Measure length "S". Refer to SDS (ST-27).

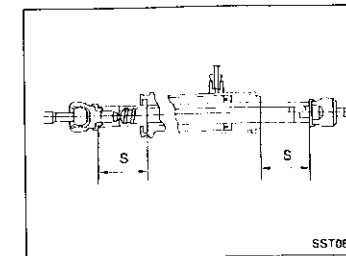



## POWER STEERING GEAR AND LINKAGE (Model PR24AC)

### Assembly (Cont'd)

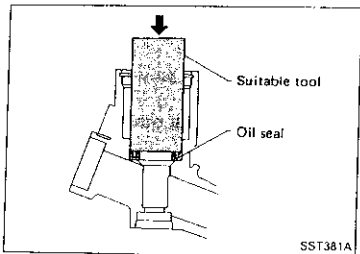

8. Coat seal lip of new pinion oil seal with multi-purpose grease. Install it into pinion housing of gear with a suitable tool.

**Make sure lip of oil seal faces up when installed.**

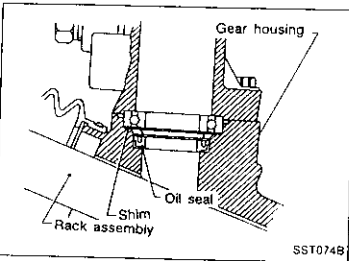

9. Install pinion bearing adjusting shim(s).  
**Whenever pinion assembly, gear housing and rear housing are disassembled, replace shim(s) with new ones. Always use the same number of shim(s) when replacing.**

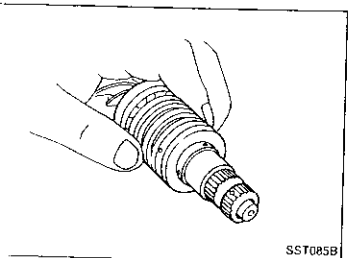

10. Install new pinion seal ring (made of Teflon) on pinion gear assembly.
- Using a heat gun, heat pinion seal ring to approximately 40°C (104°F) before installing it onto pinion gear assembly.
  - Make sure pinion seal ring is properly settled in valve groove.

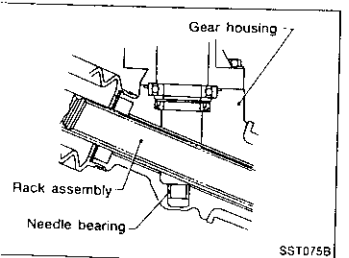

11. Apply a coat of multi-purpose grease to needle bearing roller and oil seal lip.

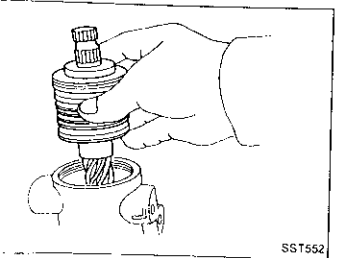

12. Install pinion assembly to rear housing.  
**Be careful not to damage pinion oil seal.**

ST-20

## POWER STEERING GEAR AND LINKAGE (Model PR24AC)

### Assembly (Cont'd)

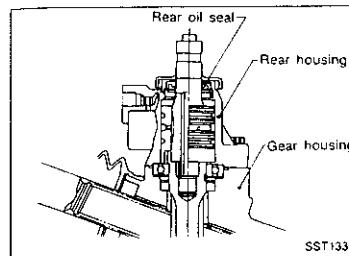

13. Apply a coat of multi-purpose grease to rear oil seal lip before installing rear housing.

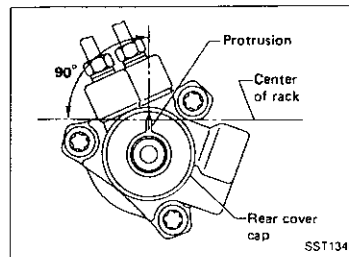

14. Ensure that the rack is centered. Install rear cover cap so that protrusion of rear housing cover is positioned as shown in figure.  
**Be careful not to damage worm ring and oil seal.**

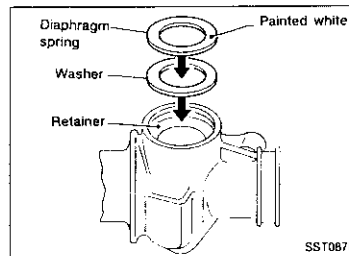

15. Install diaphragm spring at retainer.
- Always install retainer, spring washer and diaphragm spring in that order.
  - Make sure convex end (painted white) of diaphragm spring faces outward when installing.
16. Install retainer spring and adjusting screw temporarily.

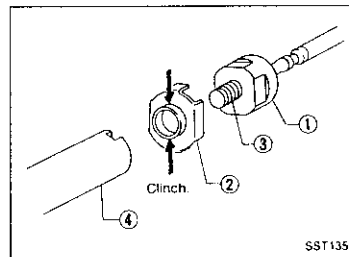

17. Install new lock plate.
- Attach lock plate ② to side rod inner socket ①.
  - Apply locking sealant to inner socket threads ③. Screw inner socket into rack ④ and tighten to specified torque.
  - Clinch two places of lock plate at rack's groove.

**CAUTION:**  
**To prevent scratching the boot, remove burrs from lock plate.**

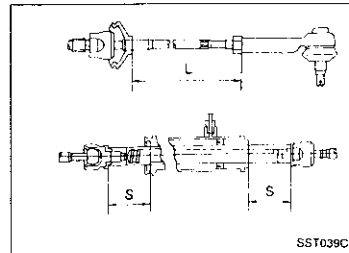

18. Tighten outer socket lock nut.  
**Tie-rod length "L":**  
**Refer to SDS (ST-27).**
19. Measure rack stroke.  
**Rack stroke "S":**  
**Refer to SDS (ST-27).**

ST-21

## POWER STEERING GEAR AND LINKAGE (Model PR24AC)

### Assembly (Cont'd)

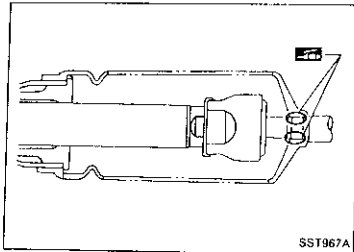

20. Before installing boot, coat the contact surfaces between boot and tie-rod with grease.

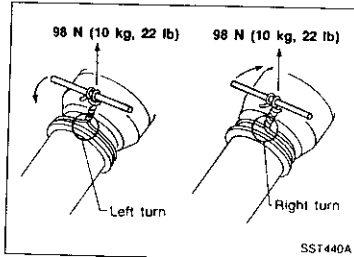

21. Install boot clamps.
- To install, wrap boot clamp around boot groove twice. To tighten clamp, place a screwdriver through both rings. Twist rings 4 to 4-1/2 turns while pulling with a force of approx. 98 N (10 kg, 22 lb).
  - Twist boot clamp in the direction shown in figure at left.

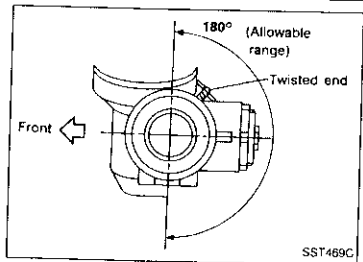

- Place twisted ends of boot clamp in the range shown. (This will prevent interference with other parts.)

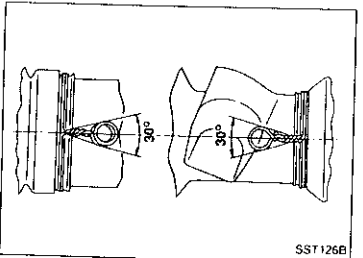

- After twisting boot clamp, bend twisted end diagonally so it does not contact boot.

### Adjustment

Adjust pinion rotating torque as follows:

- Set gears to Neutral without fluid in the gear.
- Coat the adjusting screw with locking sealant and screw it in.
- Lightly tighten lock nut.
- Tighten adjusting screw to a torque of 4.9 to 5.9 N·m (50 to 60 kg·cm, 43 to 52 in·lb).
- Loosen adjusting screw, then retighten it to 0.2 N·m (2 kg·cm, 1.7 in·lb).
- Move rack over its entire stroke several times.

## POWER STEERING GEAR AND LINKAGE (Model PR24AC)

### Adjustment (Cont'd)

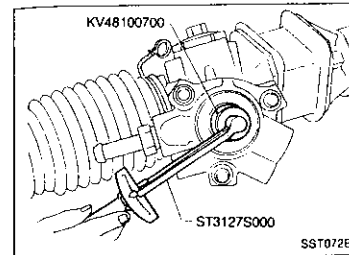

- Measure pinion rotating torque within the range of 180° from neutral position. Stop the gear at the point of maximum torque.
- Loosen adjusting screw, then retighten it to 4.9 N·m (50 kg·cm, 43 in·lb).
- Loosen adjusting screw by 70° to 110°.

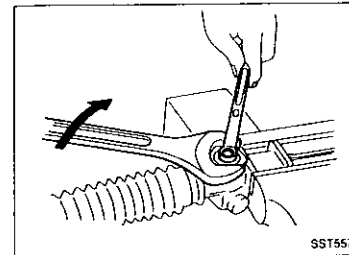

- Prevent adjusting screw from turning, and tighten lock nut to specified torque.

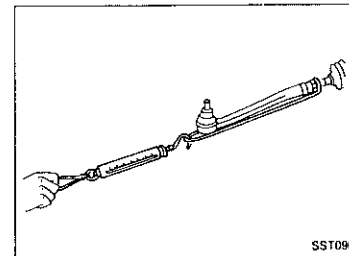

- Check rack sliding force on vehicle as follows:
  - Install steering gear onto vehicle, but do not connect tie-rod to knuckle arm.
  - Connect all piping and fill with steering fluid.
  - Start engine and bleed air completely.
  - Disconnect steering column lower joint from the gear.
  - Keep engine at idle and make sure steering fluid has reached normal operating temperature.
  - Pull tie-rod slowly to move it from neutral position to  $\pm 11.5$  mm ( $\pm 0.453$  in) at speed of 3.5 mm (0.138 in)/s. Check that rack sliding force is within specification.

**Average rack sliding force:**

186 - 245 N (19 - 25 kg, 42 - 55 lb)

**Maximum force deviation:**

98 N (10 kg, 22 lb)

- Check sliding force outside above range at rack speed of 40 mm (1.57 in)/s.

**Maximum rack sliding force:**

294 N (30 kg, 66 lb)

**Maximum force deviation:**

147 N (15 kg, 33 lb)

- If rack sliding force is not within specification, readjust by repeating adjustment procedure from the beginning.
- If rack sliding force is still out of specification after readjustment, gear assembly needs to be replaced.

Disassembly and Assembly

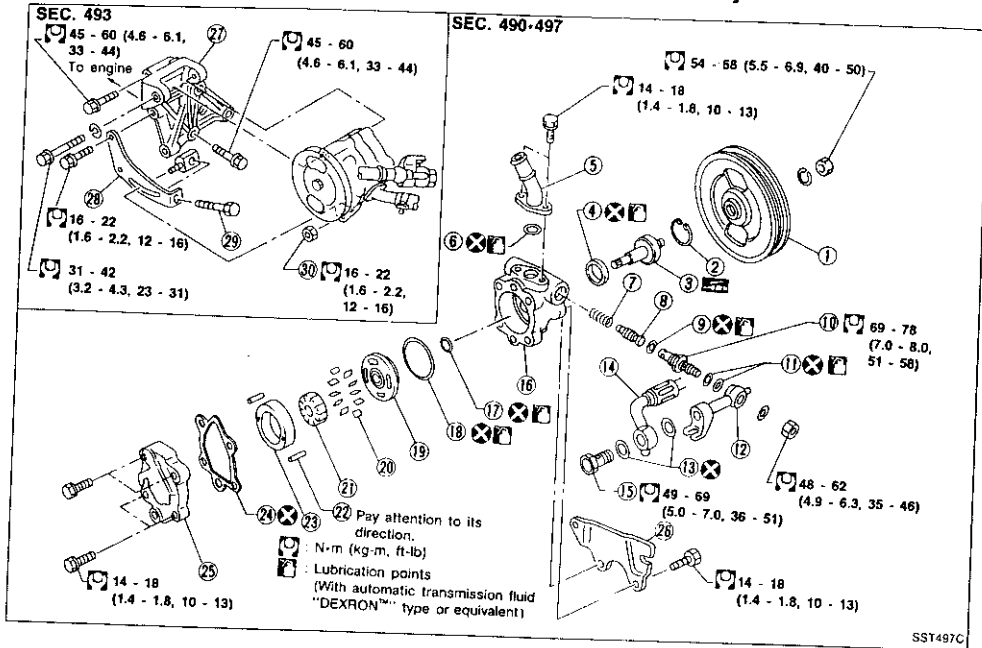

- |                        |                    |                               |
|------------------------|--------------------|-------------------------------|
| ① Pulley               | ⑪ O-ring           | ⑲ Rotor                       |
| ② Snap ring            | ⑫ Joint            | ⑳ Pin                         |
| ③ Drive shaft assembly | ⑬ Washer           | ㉑ Cam ring                    |
| ④ Oil seal             | ⑭ Hose             | ㉒ Gasket                      |
| ⑤ Suction pipe         | ⑮ Eye bolt         | ㉓ Rear cover                  |
| ⑥ O-ring               | ⑯ O-ring           | ㉔ Front bracket               |
| ⑦ Spring               | ⑰ Front side plate | ㉕ Power steering pump bracket |
| ⑧ Flow control valve   | ⑱ Vane             | ㉖ Adjusting bar               |
| ⑨ O-ring               |                    | ㉗ Adjusting bolt              |
| ⑩ Connector bolt       |                    | ㉘ Adjusting bolt lock nut     |

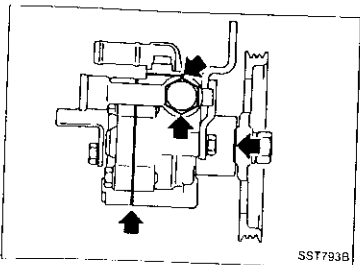

SST793B

Pre-disassembly Inspection

Disassemble the power steering oil pump only if the following items are found.

- Oil leak from any point shown in the figure.
- Deformed or damaged pulley.
- Poor performance.

Disassembly

CAUTION:

- Parts which can be disassembled are strictly limited. Never disassemble parts other than those specified.
- Disassemble in as clean a place as possible.
- Clean your hands before disassembly.
- Do not use rags; use nylon cloths or paper towels.
- Follow the procedures and cautions in the Service Manual.
- When disassembling and reassembling, do not let foreign matter enter or contact the parts.

- Remove snap ring, then draw pulley shaft out. Be careful not to drop pulley shaft.

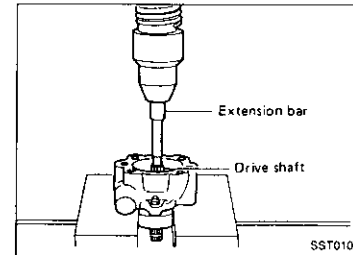

SST010B

- Remove oil seal. Be careful not to damage front housing.

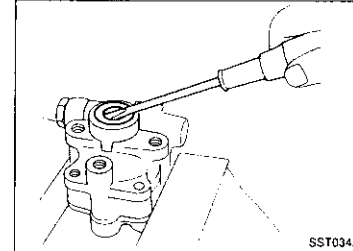

SST034A

- Remove connector. Be careful not to drop flow control valve.

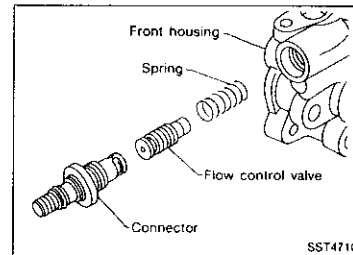

SST471C

Inspection

Inspect each component part for wear, deformation, scratches, and cracks. If damage is found, replace the part.

## POWER STEERING OIL PUMP

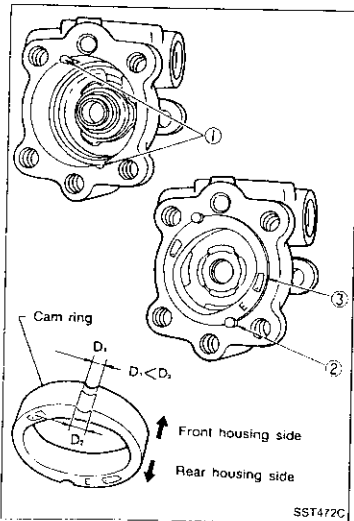
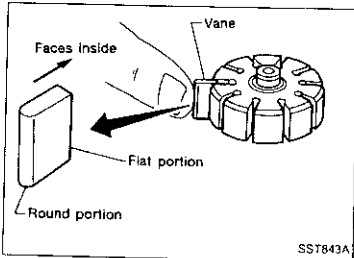
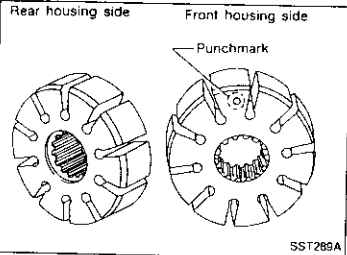
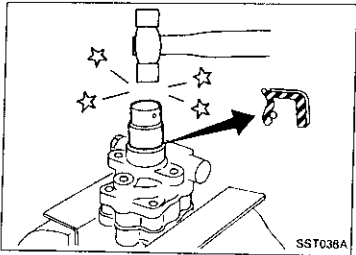

### Assembly

Assemble oil pump, noting the following instructions.

- Make sure O-rings and oil seal are properly installed.
- Always install new O-rings and oil seal.
- Be careful of oil seal direction.
- Cam ring, rotor and vanes must be replaced as a set if necessary.
- Coat each part with ATF when assembling.

- Pay attention to the direction of rotor.

- When assembling vanes to rotor, rounded surfaces of vanes must face cam ring side.

- Insert pin ② into pin groove ① of front housing and front side plate. Then install cam ring ③ as shown at left.

## SERVICE DATA AND SPECIFICATIONS (SDS)

### General Specifications

Applied model	All
Steering model	Power steering
Steering gear type	PR24AC
Steering overall gear ratio	17.2
Turns of steering wheel (Lock to lock)	3.1
Steering column type	Collapsible, tilt

### Inspection and Adjustment

#### GENERAL

Steering wheel axial play mm (in)	0 (0)
Steering wheel play limit mm (in)	35 (1.38)
Allowable movement of gear housing mm (in)	± 2 (± 0.08)

#### STEERING COLUMN

Applied model	LHD	RHD
Steering column length "L <sub>1</sub> " mm (in)	630.7 (24.83)	610.0 (24.02)
Steering column lower shaft length "L <sub>2</sub> " mm (in)	323.7 (12.74)	341.0 (13.43)

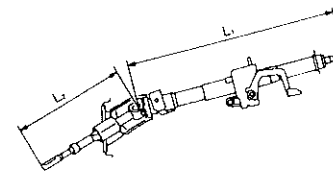

SST493C

#### STEERING GEAR AND LINKAGE

Steering gear type	PR24AC
Tie-rod outer ball joint	
Swinging force at cotter pin hole "A" N (kg, lb)	6.9 - 65.7 (0.7 - 6.7, 1.5 - 14.8)
Rotating torque "B" N·m (kg-cm, in-lb)	0.29 - 2.94 (3.0 - 30.0, 2.6 - 26.0)
Axial end play "C" mm (in)	0 (0)
Tie-rod inner ball joint	
Swinging force "A" N (kg, lb)	6.9 - 56.9 (0.7 - 5.8, 1.5 - 12.8)
Axial end play "C" mm (in)	0 (0)
Tie-rod standard length "L" mm (in)	169 (6.65)

\*: Measuring point [F: 137 mm (5.39 in)]

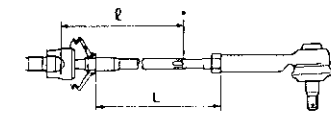

SST488C

Rack stroke "S"	mm (in)	68.5 (2.697)
-----------------	---------	--------------

ST

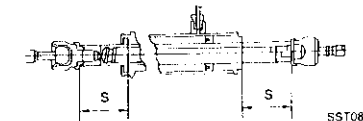

SST0868A

## SERVICE DATA AND SPECIFICATIONS (SDS)

### Inspection and Adjustment (Cont'd)

#### POWER STEERING

Steering gear type	PR24AC
Rack sliding force	N (kg, lb)
Under normal operating oil pressure	
Range within $\pm 11.5$ mm ( $\pm 0.453$ in) from the neutral position at rack speed of 3.5 mm (0.138 in)/s	
Average force	186 - 245 (19 - 25, 42 - 55)
Maximum force deviation	98 (10, 22)
Except for the above range	
Maximum sliding force	294 (30, 66)
Maximum force deviation	147 (15, 33)
Retainer adjustment	
Adjusting screw	
Initial tightening torque	4.9 - 5.9 N·m (kg-cm, in-lb)
Retightening torque after loosening	0.2 (2, 1.7)
Tightening torque after gear has settled	4.9 (50, 43)
Returning angle	degree 70° - 110°
Steering wheel turning force (Measured at one full turn from the neutral position)	39 (4, 9) or less N (kg, lb)
Fluid capacity (Approximate)	0.9 (3/4) l (Imp qt)
Oil pump maximum pressure	8,630 - 9,219 kPa (bar, kg/cm <sup>2</sup> , psi) (86.3 - 92.2, 88 - 94, 1,251 - 1,337)

## RESTRAINT SYSTEM

# SECTION RS

## CONTENTS

<b>PRECAUTION</b> .....	2	Removal — Front Passenger Air Bag Module.....	10
Supplemental Restraint System (SRS) "AIR BAG" and "SEAT BELT PRE-TENSIONER".....	2	Installation — Air Bag Module and Spiral Cable.....	11
<b>SEAT BELTS</b> .....	3	Installation — Front Passenger Air Bag Module.....	12
Front Seat Belt.....	3	Disposal of Air Bag Module and Seat Belt Pre-tensioner.....	12
Rear Seat Belt.....	4	<b>TROUBLE DIAGNOSES — Supplemental Restraint System (SRS)</b> .....	17
<b>SUPPLEMENTAL RESTRAINT SYSTEM (SRS)</b> .....	5	Wiring Diagram — SRS.....	17
Precautions for SRS "Air Bag" and "Seat Belt Pre-tensioner" Service.....	5	Schematic.....	20
Special Service Tools.....	5	Self-diagnosis.....	21
Commercial Service Tool.....	5	Diagnostic Procedure 1.....	27
Description.....	6	Diagnostic Procedure 2.....	27
SRS Component Parts Location.....	6	Diagnostic Procedure 3.....	28
Maintenance Items.....	7	Collision Diagnosis.....	29
Removal and Installation — Diagnosis Sensor Unit and Seat Belt Pre-tensioner.....	8		
Removal — Air Bag Module and Spiral Cable.....	9		

When you read wiring diagrams:

- Read GI section, "HOW TO READ WIRING DIAGRAMS".

- See EL section, "POWER SUPPLY ROUTING" for power distribution circuit.

When you perform trouble diagnoses, read GI section, "HOW TO FOLLOW FLOW CHART IN TROUBLE DIAGNOSES" and "HOW TO PERFORM EFFICIENT DIAGNOSIS FOR AN ELECTRICAL INCIDENT".

## Restraint System (SRS) "AIR SEAT BELT PRE-TENSIONER"

Seat Belt Pre-tensioner", used along with a seat belt and front passenger in a frontal collision. The seat belt pre-tensioners, a diagnosis sensor.

To reduce the risk of personal injury or death in a collision, all maintenance must be performed according to the instructions.

The installation of the SRS, can lead to personal injury.

The SRS components are covered with yellow outer insulation related to the SRS.

## SEAT BELTS

### CAUTION:

- Before removing the seat belt assembly, turn the ignition switch off, disconnect battery ground cable and wait for at least 10 minutes. (For Europe model)
- Do not disassemble buckle or seat belt assembly.
- Replace anchor bolts if they are deformed or worn out.
- Never oil tongue and buckle.
- If any component of seat belt assembly is questionable, do not repair. Replace as seat belt assembly.
- If webbing is cut, frayed, or damaged, replace seat belt assembly.
- When replacing seat belt assembly, use a genuine seat belt assembly.
- After any collision, inspect all seat belt assemblies, including retractors and other attached hardware (i.e., guide rail set).

### Front Seat Belt

- ① Remove rear seat. Refer to "SEAT" in BT section for details.
- ② Remove rear pillar lower garnish. Refer to "INTERIOR TRIM" in BT section for details.
- ③ Disconnect seat belt pre-tensioner connector. (For Europe model)
- ④ Remove floor anchor cover and the anchor bolt.
- ⑤ Remove pillar anchor cover and the anchor bolt.
- ⑥ Remove the screw and the anchor bolt securing front seat belt assembly.

SEC. 868

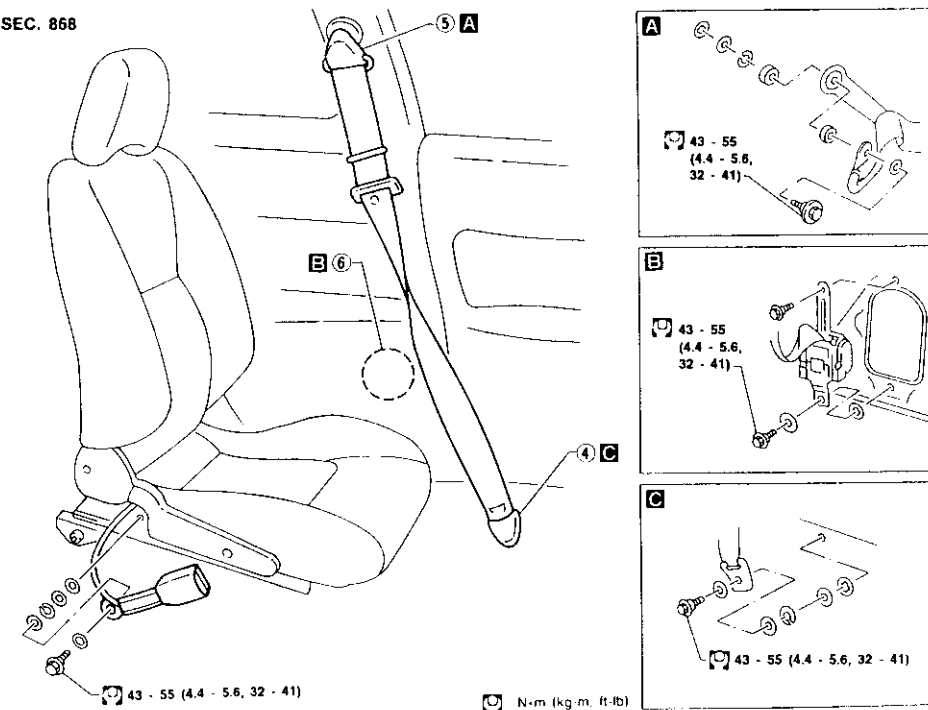

## SEAT BELTS

### Rear Seat Belt

1. Remove rear seat. Refer to "SEAT" in BT section for details.
2. Remove rear pillar lower garnish. Refer to "INTERIOR TRIM" in BT section for details.
3. Remove each anchor bolt.
4. Remove the anchor bolt securing rear seat belt assembly.

SEC. 869

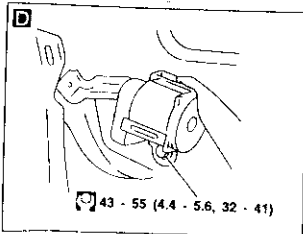
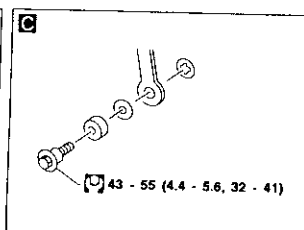
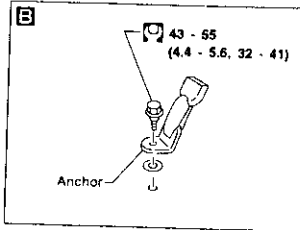
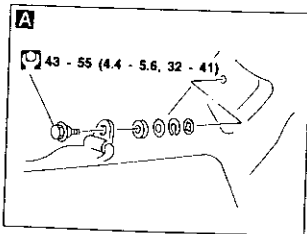
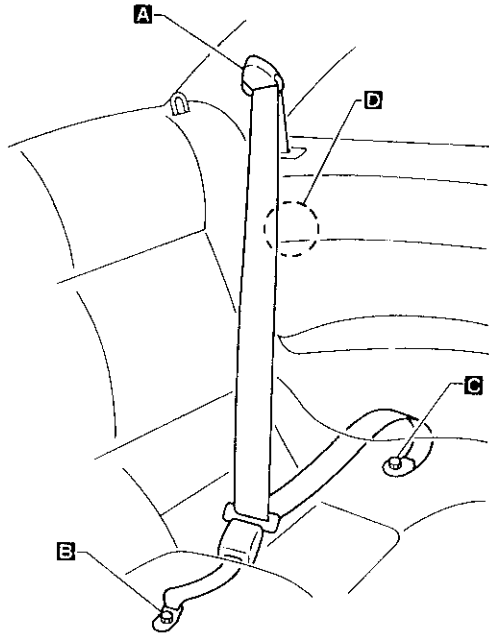

N·m (kg·m, ft·lb)

MBF4978A

RS-4

## SUPPLEMENTAL RESTRAINT SYSTEM (SRS)

### Precautions for SRS "Air Bag" and "Seat Belt Pre-tensioner" Service

- Do not use a circuit tester to check SRS circuits.
- Before servicing the SRS, turn ignition switch "OFF", disconnect battery ground cable and wait for at least 10 minutes.  
For approximately ten minutes after the cables are removed, it is still possible for the air bag and seat belt pre-tensioner to deploy. Therefore, do not work on any SRS connectors or wires until at least ten minutes have passed.
- Diagnosis sensor unit must always be installed with their arrow marks "←" pointing towards the front of the vehicle for proper operation. Also check diagnosis sensor unit for cracks, deformities or rust before installation and replace as required.
- The spiral cable must be aligned with the neutral position since its rotations are limited. Do not attempt to turn steering wheel or column after removal of steering gear.
- Handle air bag module carefully. Always place it with the pad side facing upward.
- After removing any SRS parts, discard old bolts and replace with new ones. Conduct self-diagnosis to check entire SRS for proper function.
- After air bag inflates, the front instrument panel assembly should be replaced.

### Special Service Tools

Tool number Tool name	Description
KV99106400 Deployment tool	Disposing of air bag module  NT357
KV99106550 Deployment tool adapters	For seat belt pre-tensioner For passenger air bag module  NT353
KV99105300 Passenger air bag bracket	Anchor the passenger air bag module  NT354

### Commercial Service Tool

Tool name	Description
Special torx bit	Use for special bolts [TAMPER RESISTANT TORX (Size T50)]  a: 3.5 (0.138) dia. b: 8.5 - 8.6 (0.335 - 0.339) dia. c: approx. 10 (0.39) sq. Unit: mm (in) NT361

RS-5

Description

The air bag deploys if the diagnosis sensor unit activates while the ignition switch is in "ON" or "START" position.

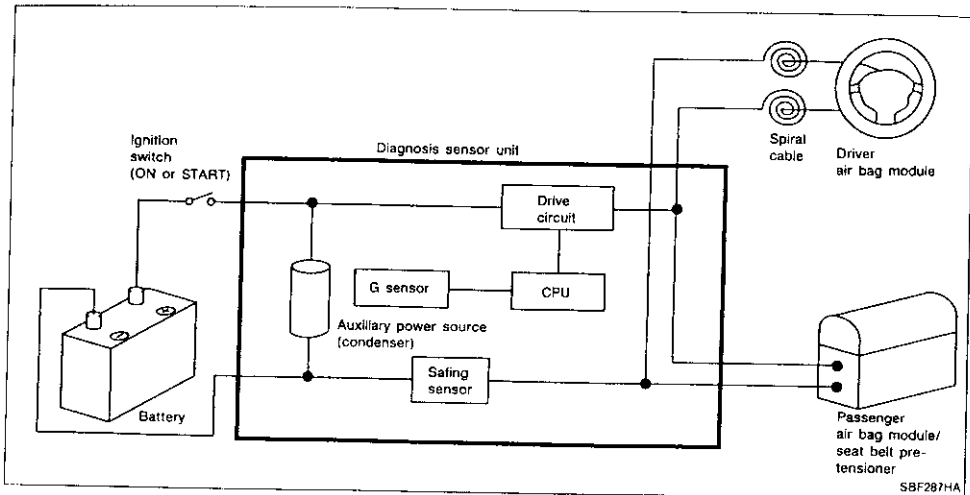

SRS Component Parts Location

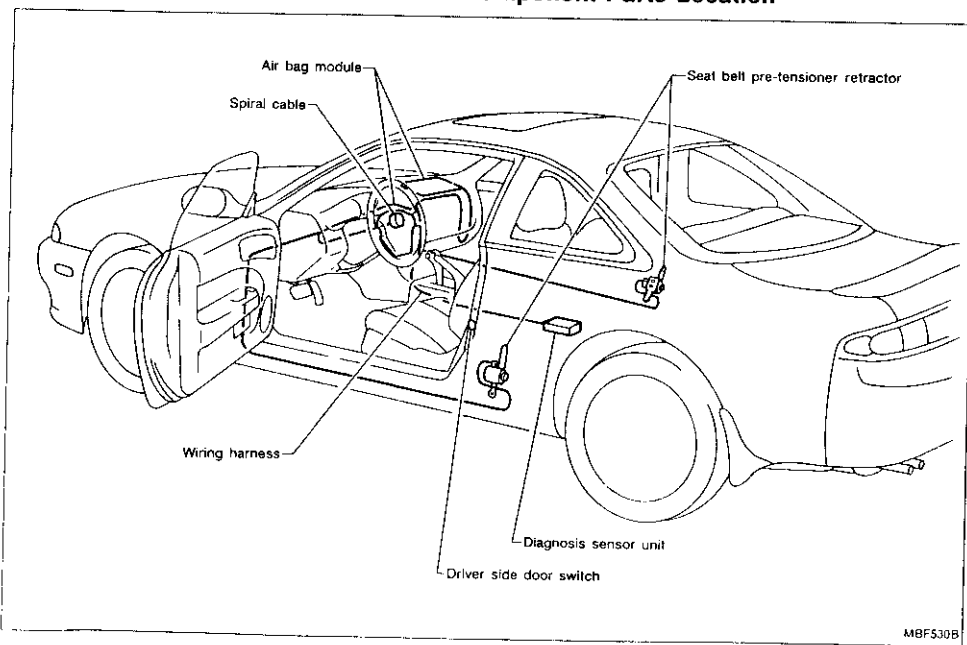

Maintenance Items

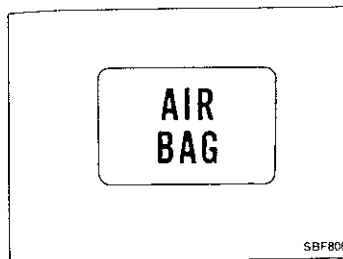

1. Check "AIR BAG" warning lamp (Models equipped with air bags)  
 After turning ignition key to "ON" or "START" position, "AIR BAG" warning lamp illuminates for about 7 seconds. The "AIR BAG" warning lamp will go out after about 7 seconds, if no malfunction is detected.  
 When a warning lamp flashes, check and correct cause of the problem.

2. Visually check SRS components

(1) Diagnosis sensor unit — Airbag

- Check case and bracket for dents, cracks or deformities.
- Check connectors for damage, and terminals for deformities.

(2) Main harness and air bag harness

- Check connectors for poor connections.
- Check harnesses for binding, connectors for damage, and terminals for deformities.

(3) Spiral cable

- Visually check lock (engagement) pins and combination switch for damage.
- Check connectors, flat cable and protective tape for damage.
- Check steering wheel for noise, binding or difficult operation.

(4) Air bag module and steering wheel

- Remove air bag module from steering wheel or instrument panel. Check harness cover and connectors for damage, terminals for deformities, and harness for binding.
- Install driver side air bag module to steering wheel to check fit or alignment with the wheel.
- Check steering wheel for excessive free play.
- Install passenger side air bag module to instrument panel to check fit or alignment with the instrument panel.

**CAUTION:**

Replace previously used screws with new ones.

(5) Seat belt pre-tensioner

- Check harness cover and connectors for damage, terminals for deformities, and harness for binding.
- Check belts for damage and anchors for loose mounting.
- Check retractor for smooth operation.
- Perform self-diagnosis for seat belt pre-tensioner using circuit tester. Refer to "Self-diagnosis" for details. (RS-21)



GI

ME

EW

LG

PC

FE

GI

(b)  
480B

MT

ect

AT

ect

PC

EA

RA

IRX

ag

RA

ST

RS

ST

rd.

PC

ard

PC

PC

## PLEMENTAL RESTRAINT SYSTEM (SRS)

### Removal — Front Passenger Air Bag Module (Cont'd)

- Do not drop or impact air bag module. If any portion is deformed or cracked, replace the module.
- Do not expose the air bag module to temperatures exceeding 93°C (199°F).
- Do not allow oil, grease or water to come in contact with the air bag module.



SBF814E

### Installation — Air Bag Module and Spiral Cable

1. Set the front wheels in the straight-ahead position.
2. Make sure that the spiral cable is in the neutral position. The neutral position is detected by turning left 2.5 revolutions from the right end position. Align the two marks (X).

#### CAUTION:

The spiral cable may snap due to steering operation if the cable is installed in an improper position.

Also, with the steering linkage disconnected, the cable may snap by turning the steering wheel beyond the limited number of turns. (The spiral cable can be turned up to 2.5 turns from the neutral position to both the right and left.)

3. Connect spiral cable connector and tighten with screws. Install steering column cover.

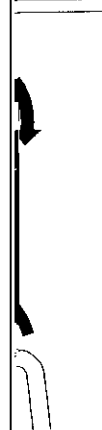

MBF487B

4. Install steering wheel setting spiral cable pin guides, and pull spiral cable through.
5. Connect horn connector and engage spiral cable with pawls in steering wheel.
6. Tighten nuts.



SBF818E

pecial bolt  
15 - 25  
(1.5 - 2.5,  
11 - 18)

7. Position air bag module and tighten with new special bolts.
8. Connect air bag module connector.
9. Install all lids.
10. Conduct self-diagnosis to ensure entire SRS operates properly. (Use CONSULT or warning lamp check )

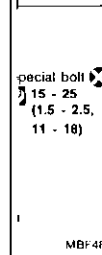

MBF488B

## SUPPLEMENTAL RESTRAINT SYSTEM (SRS)

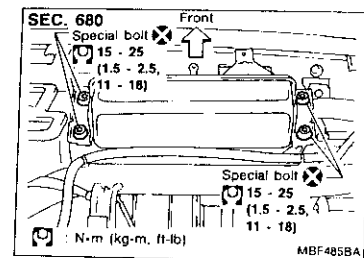

### Installation — Front Passenger Air Bag Module

1. Install front passenger air bag module on steering member.
2. Install instrument panel.
3. Connect air bag module connector to body harness connector.
4. Install air bag module connector on connector bracket.
5. Install connector bracket on air bag module.

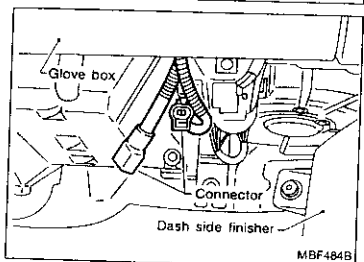

### Disposal of Air Bag Module and Seat Belt Pre-tensioner

- Make sure to deactivate air bag modules and seat belt pre-tensioners before disposing of them. Also, before disposing of a vehicle equipped with an SRS system, deactivate air bag modules and seat belt pre-tensioners. If such systems have already been deployed due to an accident, dispose of as indicated in "DISPOSING OF AIR BAG MODULE AND SEAT BELT PRE-TENSIONER".
- When deploying the air bag module and seat belt pre-tensioner, always use the Special Service Tool; Deployment tool KV99106400.
- When deploying the air bag module and seat belt pre-tensioner, stand at least 5 m (16 ft) away from the deployment component.
- Due to heat, do not touch air bag module for at least 30 minutes after deployment. Also do not touch seat belt pre-tensioner for at least 10 minutes after deployment.
- Be sure to wear gloves when handling a deployed air bag module and seat belt pre-tensioner.
- Never apply water to a deployed air bag module and seat belt pre-tensioner.
- Wash your hands clean after finishing work.

## SUPPLEMENTAL RESTRAINT SYSTEM (SRS)

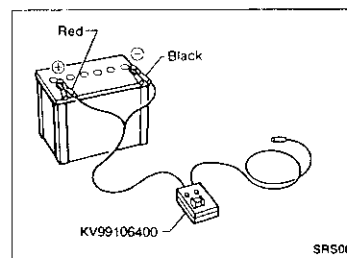

### Disposal of Air Bag Module and Seat Belt Pre-tensioner (Cont'd)

#### CHECKING DEPLOYMENT TOOL

##### Connecting to battery

- Place vehicle outdoors with at least 6 m (20 ft) of open space on all sides.
- Use a voltmeter to make sure the vehicle battery is fully charged.

##### CAUTION:

The battery must show voltage of 9.6V or more.

Remove the battery from the vehicle and place it on dry wood blocks approximately 5 m (16 ft) away from the vehicle.

- Wait 10 to 12 minutes after the vehicle battery is disconnected before proceeding.
- Connect red clip of deployment tool to battery positive terminal and black clip to negative terminal.

##### CAUTION:

Make sure the polarity is correct. The right side lamp in the tool, marked "deployment tool power", should glow with a green light. If the right side lamp glows red, reverse the connections to the battery.

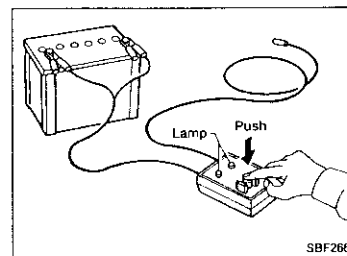

##### Deployment tool check

Press the deployment tool switch to the "ON" position. The left side lamp in the tool, marked "air bag connector voltage" should illuminate. If it does not illuminate, replace the tool.

#### Air bag deployment tool lamp illumination chart (Battery connected)

Switch operation	Left side lamp, green* "AIR BAG CONNECTOR VOLTAGE"	Right side lamp, green* "DEPLOYMENT TOOL POWER"
OFF	OFF	ON
ON	ON	ON

\* If this lamp glows red, the tool is connected to the battery incorrectly. Reverse the connections and make sure the lamp glows green.

## AIR BAG SYSTEM (SRS)

### Front Air Bag Module and Seat Belt

#### Preparation (Cont'd)

Anchor passenger air bag bracket in a vise.  
Connect deployment tool adapter (SST: KV991065S0) to front air bag connector and connector on the inner side of air bag module.

Connect red clip of deployment tool to battery positive terminal and black clip to negative terminal.  
The lamp on the right side of the tool, marked "deployment tool", should glow green, not red.  
The lamp on the left side of the tool, marked "air bag connector voltage", will illuminate when the air bag module will deploy.

When testing the air bag module, stand at least 5 m (16 ft) away from the air bag module.

Test one inflator at a time.

#### Preparation of seat belt pre-tensioner as a unit

Anchor seat belt pre-tensioner in a vise.

Coil and webbing are placed in the vise.

Connect deployment tool adapter (SST: KV991065S0) to front air bag connector and seat belt pre-tensioner connector.

Connect red clip of deployment tool to battery positive terminal and black clip to negative terminal.  
The lamp on the right side of the tool, marked "deployment tool", should glow green, not red.  
The lamp on the left side of the tool, marked "air bag connector voltage", will illuminate when the seat belt pre-tensioner will deploy.

When testing the seat belt pre-tensioner, stand at least 5 m (16 ft) away from the seat belt pre-tensioner.

## SUPPLEMENTAL RESTRAINT SYSTEM (SRS)

### Disposal of Air Bag Module and Seat Belt Pre-tensioner (Cont'd)

#### DEPLOYMENT OF AIR BAG MODULE AND SEAT BELT PRE-TENSIONER WHILE MOUNTED IN VEHICLE

When disposing of a vehicle, deploy air bag modules and seat belt pre-tensioners while they are mounted in vehicle.

#### CAUTION:

When deploying air bag module or seat belt pre-tensioner, ensure vehicle is empty.

1. Disconnect battery ground cable and wait 10 minutes.
2. Disconnect air bag modules and seat belt pre-tensioners connector.
3. Connect deployment tool connector (SST: KV99106400) to air bag module or seat belt pre-tensioner.  
For front passenger air bag module and seat belt pre-tensioner, attach deployment tool adapters (SST: KV991065S0) to the tool connector.
4. Connect red clip of deployment tool to battery positive terminal and black clip to negative terminal.
5. The lamp on the right side of the tool, marked "deployment tool power", should glow green, not red.
6. Press the button on the deployment tool. The left side lamp on the tool, marked "air bag connector voltage", will illuminate and the air bag module or seat belt pre-tensioner will deploy.
7. After deployment, remove them from vehicle and seal them up in plastic bags, then dispose of them.

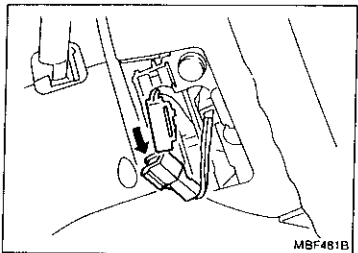

MBF481B

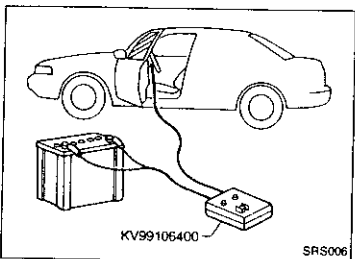

KV99106400

SRS006

#### DISPOSING OF AIR BAG MODULE AND SEAT BELT PRE-TENSIONER

Deployed air bag modules and seat belt pre-tensioners are very hot. Before disposing of air bag module, and seat belt pre-tensioner, wait at least 30 minutes, and 10 minutes, respectively. Seal them in a plastic bag before disposal.

#### CAUTION:

- Never apply water to a deployed air bag module and seat belt pre-tensioner.
- Be sure to wear gloves when handling a deployed air bag module and seat belt pre-tensioner.
- No poisonous gas is produced upon air bag module deployment. However, be careful not to inhale gas since it irritates throat and can cause choking.
- Do not attempt to disassemble air bag module and seat belt pre-tensioner.
- Air bag module and seat belt pre-tensioner can not be re-used.
- Wash your hands clean after finishing work.

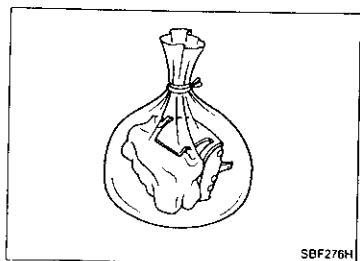

SBF276H

RS-16

## TROUBLE DIAGNOSES — Supplemental Restraint System (SRS)

### Wiring Diagram — SRS —

RS-SRS-01

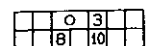
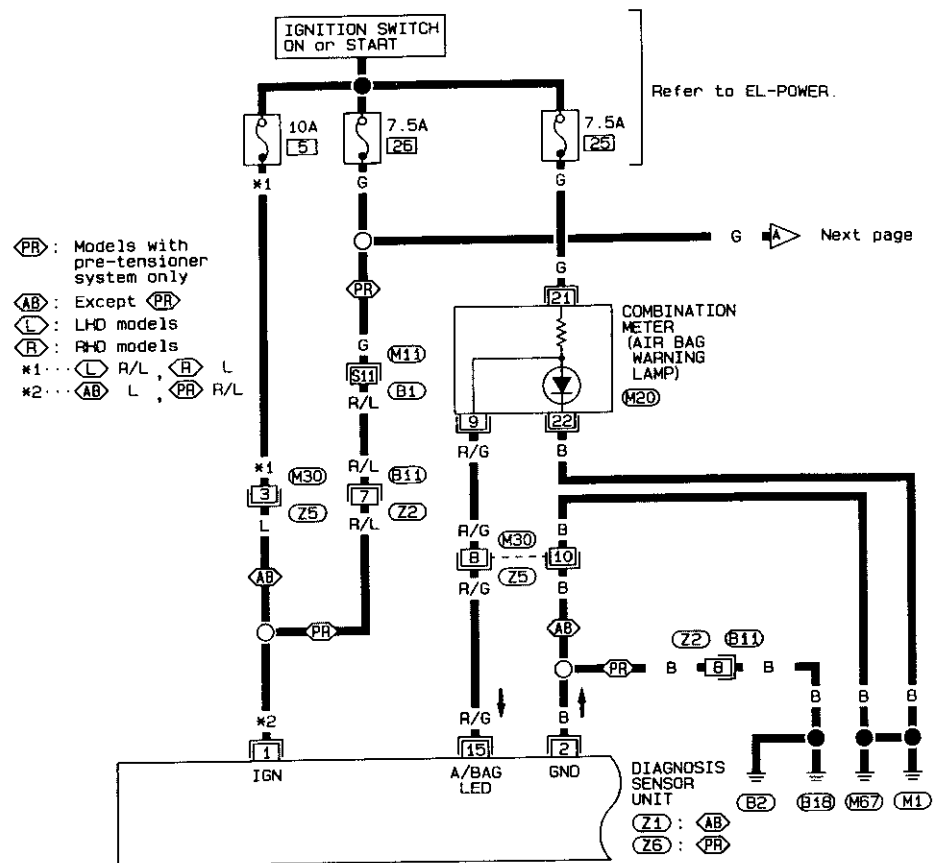

Z5  
W

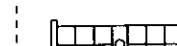

M20  
W



B11  
W

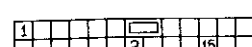

Z1: AB  
Y

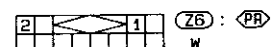

Z6: PR  
W

Refer to last page (Foldout page).

M11, B1

SRS007

RS-17

1  
2  
3  
4  
5  
6  
7  
8  
9  
10  
11  
12  
13  
14  
15  
16  
17  
18  
19  
20  
21  
22  
23  
24  
25  
26  
27  
28  
29  
30  
31  
32  
33  
34  
35  
36  
37  
38  
39  
40  
41  
42  
43  
44  
45  
46  
47  
48  
49  
50  
51  
52  
53  
54  
55  
56  
57  
58  
59  
60  
61  
62  
63  
64  
65  
66  
67  
68  
69  
70  
71  
72  
73  
74  
75  
76  
77  
78  
79  
80  
81  
82  
83  
84  
85  
86  
87  
88  
89  
90  
91  
92  
93  
94  
95  
96  
97  
98  
99  
100

18

# TROUBLE DIAGNOSES — Supplemental Restraint System (SRS)

## Self-diagnosis

The air bag and seat belt pre-tensioner can be put under self-diagnosis by the following methods.

	USING CIRCUIT TESTER	USING CONSULT	USING "AIR BAG" WARNING LAMP
	RS-21	RS-22	RS-24
For Europe	Seat belt pre-tensioner (Standard equipment)	○	
	Equipped with driver air bag		○
	Equipped with driver air bag and passenger air bag		○
Europe	Equipped with driver air bag	○	○
	Equipped with driver air bag and passenger air bag		○
or Australia		○	○

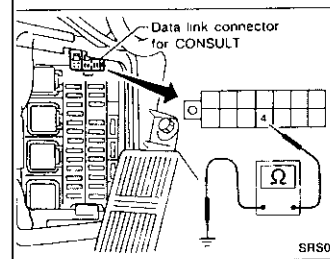

### USING CIRCUIT TESTER

Seat belt pre-tensioner self-diagnosis results can be read by using a circuit tester as follows:

1. Measure resistance between data link connector for CONSULT and body ground.

Visually check the oscillation of circuit tester needle.

#### Normal

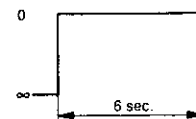

No problem.  
The seat belt pre-tensioner is in good order

#### Malfunction (including when seat belt pre-tensioner is deployed)

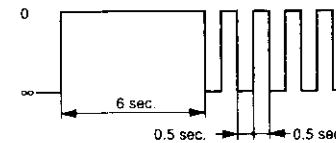

● Seat belt pre-tensioner circuit is open or shorted to some power supply circuit, or shorted to ground

1. Visually check wiring harness connections.
  2. Replace seat belt assembly (Before disposing, it must be deactivated)
  3. Replace diagnosis sensor unit
  4. Replace air bag harness
  5. Replace main harness.
- (Recheck seat belt pre-tensioner using circuit tester at each replacement)

## TROUBLE DIAGNOSES — Supplemental Restraint System (SRS)

### Self-diagnosis (Cont'd)

#### USING CONSULT

The self-diagnosis results can be read by CONSULT, as follows:

1. Connect "CONSULT" to data link connector for CONSULT. (Data link connector for CONSULT is located in left or right dash side panel.)
  2. Turn ignition switch to "ON". (When CONSULT is connected, the "AIR BAG" warning lamp will be turned to present diagnosis mode.)
  3. Touch "START" to operate "CONSULT".
  4. Touch "AIR BAG" to choose air bag system.
  5. Touch "SELF DIAG RESULTS" to read self-diagnosis results.
  6. Problem codes are displayed on "SELF DIAG RESULTS".
  7. When "PRINT" is pressed, information displayed on "SELF DIAG RESULTS" is printed out.
- WARNING:**
- While CONSULT is displaying this "SELF-DIAG RESULTS" information, do not disconnect CONSULT from data link connector.
  - When finishing diagnosis, make sure to change CONSULT display to SELECT SYSTEM mode by using BACK KEY.
8. After repairing malfunctioning parts, press "ERASE" to clear self-diagnosis results.
  - "ERASE" function requires selecting "ERASE", and completing step 9.
  9. Push BACK KEY of CONSULT until SELECT SYSTEM mode appears to make "SELF-DIAGNOSIS" user mode.
  - If malfunctioning parts are not completely repaired, "AIR BAG" warning lamp will blink every 0.5 seconds.
  10. Push the power off switch.
  11. Turn off ignition switch, disconnect CONSULT.
  12. Turn ignition switch to "ON". "AIR BAG" warning lamp should come on for about 7 seconds and then go off.

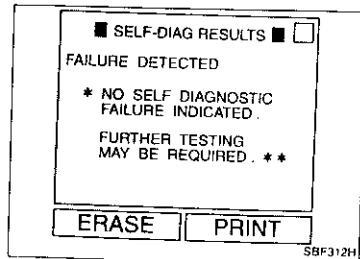
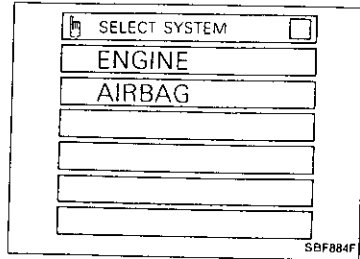
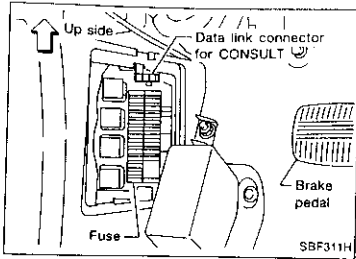

## TROUBLE DIAGNOSES — Supplemental Restraint System (SRS)

### Self-diagnosis (Cont'd)

#### Self-diagnosis results

Diagnostic item	Explanation/Possible causes	Repair order * Recheck SRS using CONSULT at each replacement.
NO SELF DIAGNOSTIC FAILURE INDICATED.	• Normal. SRS system is in good order	—
AIRBAG MODULE [OPEN]	• Driver's air bag module circuit is open (including the spiral cable).	1 Visually check wiring harness connections 2. Replace spiral cable.
AIRBAG MODULE [VB-SHORT]	• Driver's air bag module circuit is shorted to some power supply circuit (including the spiral cable).	3. Replace driver's air bag module. (Before disposing of it, it must be deployed.) 4. Replace diagnosis sensor unit.
AIRBAG MODULE [GND-SHORT]	• Driver's air bag module circuit is shorted to ground (including the spiral cable).	5. Replace air bag harness. 6. Replace main harness
AIRBAG MODULE [SHORT]	• Driver's air bag module circuits are shorted to each other.	
ASSIST A/B MODULE*1 [OPEN]	• Front passenger air bag module circuit is open.	1. Visually check wiring harness connections 2. Replace front passenger air bag module. (Before disposal of it, it must be deployed.)
ASSIST A/B MODULE*1 [VB-SHORT]	• Front passenger air bag module circuit is shorted to some power supply circuit.	3. Replace diagnosis sensor unit.
ASSIST A/B MODULE*1 [GND-SHORT]	• Front passenger air bag module circuit is shorted to ground.	4. Replace air bag harness. 5. Replace main harness.
ASSIST A/B MODULE*1 [SHORT]	• Front passenger air bag module circuits are shorted to each other.	
CONTROL UNIT	• Diagnosis sensor unit is out of order.	1 Visually check wiring harness connections. 2. Replace diagnosis sensor unit. 3. Replace air bag harness. 4. Replace main harness.
INDEFINITE FAILURES [AIR BAG]	• A problem which cannot be specified occurs because more than two parts are out of order	1. Visually check wiring harness connections 2. Replace diagnosis sensor unit. 3. Replace spiral cable and air bag modules. 4. Replace air bag harness. 5. Replace main harness.

\*1: For Australia model only



## DOUBLE DIAGNOSES — Supplemental Restraint System (SRS)

### Self-diagnosis (Cont'd)

#### USING "AIR BAG" WARNING LAMP

Air bag self-diagnosis results can be read by using the "AIR BAG" warning lamp.

The "Air bag" warning lamp operates as shown below:

#### WARNING:

When the "AIR BAG" warning lamp is flashing, compare the flash time to the chart below.

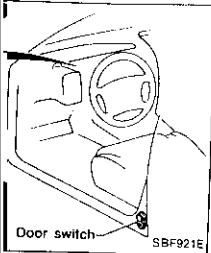

### How to self-diagnose

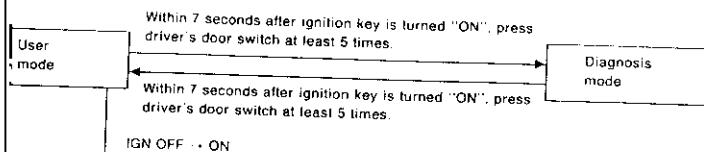

Results to be displayed in diagnosis mode (self-diagnosis results).

### Indication

If a malfunctioning part, use driver's door switch to return the system to user mode. This diagnosis results from memory. If a malfunctioning part is not completely repaired, self-diagnosis results will not be cleared.

<p>SBF298H</p>	No problem.
<p>SBF299HA</p>	The system has problem. Perform self-diagnosis with "Diagnosis mode".
<p>or diagnosis sensor unit is malfunctioning and continuously sends an "ON" signal</p> <p>SBF284HA</p>	The system needs to be repaired. (Refer to page RS-26.)

## TRouble DIAGNOSES — Supplemental Restraint System (SRS)

### Self-diagnosis (Cont'd)

#### Diagnosis mode (Self-diagnosis result)

● Indicate malfunctioning part — The system needs to be repaired.

ⓐ Start signal. Start signal identifies display modes

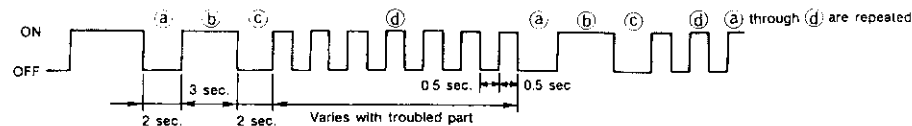

SBF300H

● No malfunctioning (or intermittent trouble/repair completion)

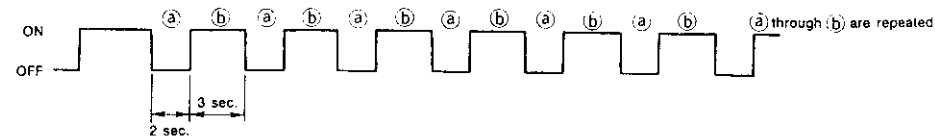

SBF285H

#### WARNING:

● After the malfunctioning parts have been repaired, return the system to "User mode".

Self-diagnosis results in diagnosis mode can be identified by number of flashes ⓐ. Refer to Table on next page for troubled parts.

## TROUBLE DIAGNOSES — Supplemental Restraint System (SRS)

### Self-diagnosis (Cont'd)

#### Warning lamp flashing times and repair

Warning lamp	Flash code (④) (# of flashes)	Explanation/Possible causes	Repair order * Recheck SRS at each replacement
"AIR BAG" warning lamp	0	<ul style="list-style-type: none"> <li>Normal. SRS "Air Bag" is in good order.</li> </ul>	—
	2	<ul style="list-style-type: none"> <li>Driver's air bag module circuit is out of order.</li> </ul>	<ol style="list-style-type: none"> <li>1. Visually check wiring harness connections.</li> <li>2. Replace spiral cable</li> <li>3. Replace driver's air bag module. (Before disposal of it, it must be deployed.)</li> <li>4. Replace diagnosis sensor unit.</li> <li>5. Replace air bag harness.</li> <li>6. Replace main harness.</li> </ol>
	7	<ul style="list-style-type: none"> <li>Diagnosis sensor unit is out of order</li> </ul>	<ol style="list-style-type: none"> <li>1. Visually check wiring harness connections.</li> <li>2. Replace diagnosis sensor unit.</li> <li>3. Replace air bag harness.</li> <li>4. Replace main harness.</li> </ol>
	8	<ul style="list-style-type: none"> <li>Front passenger air bag module circuit is out of order.</li> </ul>	<ol style="list-style-type: none"> <li>1. Visually check wiring harness connections.</li> <li>2. Replace front passenger air bag module. (Before disposal, it must be deployed.)</li> <li>3. Replace diagnosis sensor unit.</li> <li>4. Replace air bag harness.</li> <li>5. Replace main harness.</li> </ol>
	9	<ul style="list-style-type: none"> <li>More than two parts groups are out of order.</li> </ul>	<ol style="list-style-type: none"> <li>1. Visually check wiring harness connections.</li> <li>2. Replace diagnosis sensor unit.</li> <li>3. Replace all sensors, spiral cable and air bag module.</li> <li>4. Replace air bag harness.</li> <li>5. Replace main harness.</li> </ol>

## TROUBLE DIAGNOSES — Supplemental Restraint System (SRS)

### Diagnostic Procedure 1

**SYMPTOM:** "AIR BAG" warning lamp flashes.

**WARNING:**

Determine if the flash rate is every 0.5 seconds, or 3 seconds "ON" and 2 seconds "OFF".

If every 0.5 seconds, perform self-diagnosis.

If 3 seconds "ON" and 2 seconds "OFF", the system is in Present diagnosis mode, refer to page RS-24 for instructions.

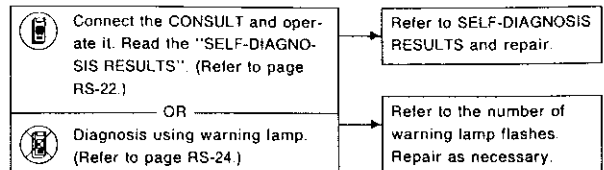
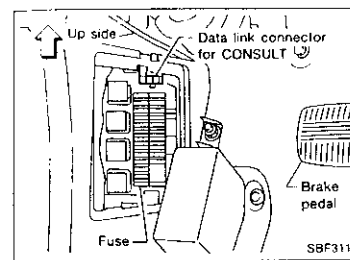

### Diagnostic Procedure 2

**SYMPTOM:** "AIR BAG" warning lamp does not come on.

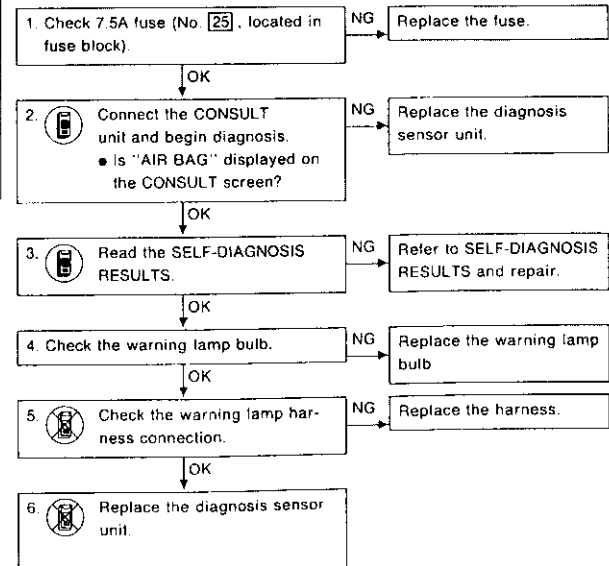

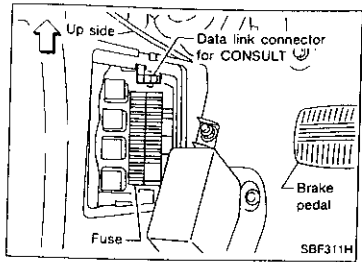

**Diagnostic Procedure 3**

**SYMPTOM: Warning lamp does not go off.**

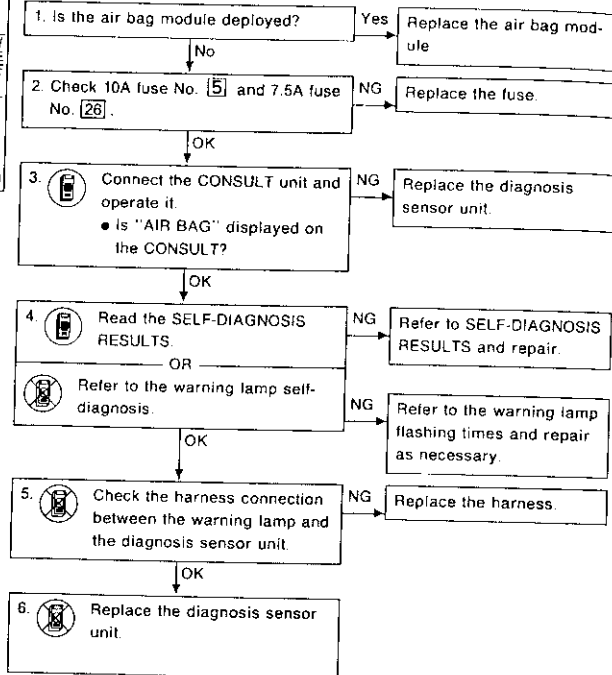

**Collision Diagnosis**

To repair the SRS, perform the following steps.

**When air bag deploys in a collision:**

- ① Replace the diagnosis sensor unit.
- ② Remove the air bag modules and seat belt pre-tensioners.
- ③ Check the SRS components using the table shown below:
  - Replace any SRS components showing visible signs of damage (dents, cracks, deformation).
- ④ Conduct self-diagnosis. Refer to "Self-diagnosis" for details (RS-21). Ensure the remainder of the SRS is operating properly.
- ⑤ Install new air bag modules.
- ⑥ Conduct self-diagnosis again.

**When air bag does not deploy in a collision:**

- ① Check the SRS components using the table shown below:
  - Replace any SRS components showing visible signs of damage (dents, cracks, deformation).
- ② Conduct self-diagnosis. Refer to "Self-diagnosis" for details (RS-21). Ensure entire SRS operates properly.

**SRS inspection**

Part	Air bag deployed	Air bag did NOT deploy
Air bag module (driver and passenger side)	REPLACE Install with new bolts.	1. Remove air bag module. Check harness cover and connectors for damage, terminals for deformities, and harness for binding. 2-1. Install driver air bag module into the steering wheel to check fit and alignment with the wheel. 2-2. Install passenger air bag module into the instrument panel to check fit with the instrument panel. 3. No damage found, reinstall with new bolts. 4. If damaged—REPLACE. <b>Air bag must be deployed before discarding.</b>
Instrument panel	REPLACE Install with new bolts.	1. Check instrument panel for bending, deformities, or cracks. 2. If no damage is found, reinstall with new bolts. 3. If damaged—REPLACE.
Seat belt pre-tensioner assembly	REPLACE Install with new bolts.	1. Remove seat belt pre-tensioners. Check harness cover and connectors for damage, terminals for deformities, and harness for binding. 2. Check belts for damage and anchors for loose mounting. 3. Check retractor for smooth operation. 4. If no damage is found, reinstall with new bolts. 5. If damaged—REPLACE.
Diagnosis sensor unit	REPLACE Install with new bolts.	1. Check case and bracket for dents, cracks or deformities. 2. Check connectors for damage, and terminals for deformities 3. If no damage is found, reinstall with new bolts. 4. If damaged—REPLACE.
Steering wheel		1. Check harness (built into steering wheel) and connectors for damage, and terminals for deformities. 2. Install air bag module to check fit or alignment with steering wheel 3. Check steering wheel for excessive free play. 4. If no damage is found, reinstall with new bolts. 5. If damaged—REPLACE
Spiral cable		1. Visually check lock (engagement) pins and combination switch for damage. 2. Check connectors, flat cable and protective tape for damage. 3. Check steering wheel for noise, binding or heavy operation. 4. If no damage is found, reinstall with new bolts. 5. If damaged—REPLACE
Harness and Connectors		1. Check connectors for poor connection, damage, and terminals for deformities. 2. Check harness for binding, chafing, cuts, or deformities 3. If no damage is found, reinstall 4. Damaged—REPLACE damaged section of harness. Do not attempt to repair, splice or modify any SRS harness.

# BODY AND TRIM

## SECTION **BT**

### CONTENTS

<b>GENERAL SERVICING</b> .....	2	<b>SEAT</b> .....	27
Precautions.....	2	Front Seat.....	27
Supplemental Restraint System (SRS) "AIR BAG" and "SEAT BELT PRE-TENSIONER".....	2	Rear Seat.....	30
Clip and Fastener.....	3	<b>SUN ROOF</b> .....	31
<b>BODY END</b> .....	6	<b>WINDSHIELD AND WINDOWS</b> .....	35
Body Front End.....	6	Windshield and Rear Window.....	35
Body Rear End and Opener.....	8	Side Window.....	36
<b>DOOR</b> .....	10	<b>DOOR MIRROR</b> .....	37
Door Glass Fitting Adjustment.....	11	<b>FRONT AND REAR AIR SPOILER</b> .....	38
<b>INSTRUMENT PANEL</b> .....	14	Front Air Spoiler.....	38
<b>INTERIOR TRIM</b> .....	17	Rear Air Spoiler.....	38
<b>EXTERIOR TRIM</b> .....	22	<b>BODY ALIGNMENT</b> .....	39
		Engine Compartment.....	39
		Underbody.....	41

★ For seat belt, refer to MA and RS sections.

★ For body electrical systems, refer to EL section.

Precautions

- When removing or installing various parts, place a cloth or padding onto the vehicle body to prevent scratches.
- Handle trim, molding, instruments, grille, etc. carefully during removing or installation. Be careful not to soil or damage them.
- Apply sealing compound where necessary when installing parts.
- When applying sealing compound, be careful that the sealing compound does not protrude from parts.
- When replacing any metal parts (for example body outer panel, members, etc.), be sure to take rust prevention measures.

Supplemental Restraint System (SRS) "AIR BAG" and "SEAT BELT PRE-TENSIONER"

The Supplemental Restraint System "Air Bag" and "Seat Belt Pre-tensioner", used along with a seat belt, help to reduce the risk or severity of injury to the driver and front passenger in a frontal collision. The Supplemental Restraint System consists of air bag modules (located in the center of the steering wheel and on the instrument panel on the passenger side), seat belt pre-tensioners, a diagnosis sensor unit, warning lamp, wiring harness and spiral cable. Information necessary to service the system safely is included in the RS section of this Service Manual.

WARNING:

- To avoid rendering the SRS inoperative, which could increase the risk of personal injury or death in the event of a collision which would result in air bag inflation, all maintenance must be performed by an authorized NISSAN dealer.
- Improper maintenance, including incorrect removal and installation of the SRS, can lead to personal injury caused by unintentional activation of the system.
- All SRS air bag electrical wiring harnesses and connectors are covered with yellow outer insulation. Do not use electrical test equipment on any circuit related to the SRS.

Clip and Fastener

- Clips and fasteners in BT section correspond to the following numbers and symbols.
- Replace any clips and/or fasteners which are damaged during removal or installation.

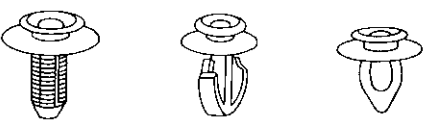
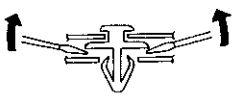
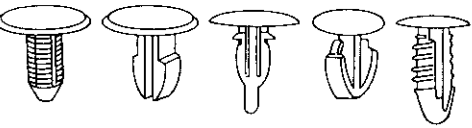
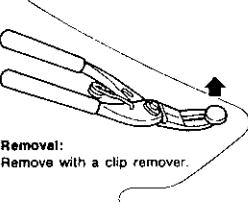
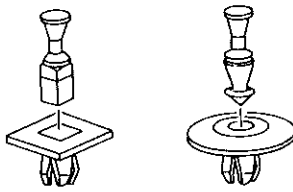
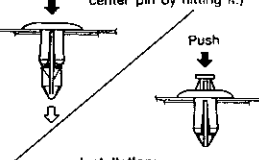
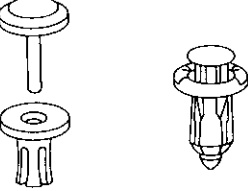
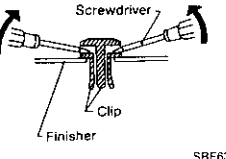
Symbol No.	Shapes	Removal & installation
C181		<p>Removal: Remove by bending up with flat-bladed screwdrivers or clip remover.</p> 
	SBF302H	SBF367BA
C183		<p>Removal: Remove with a clip remover.</p> 
	SBF303H	SBF423H
C203		<p>Push center pin to catching position. (Do not remove center pin by hitting it.)</p>  <p>Installation:</p>
	SBF258G	SBF708E
C205		<p>Removal:</p> 
	MBF518B	SBF638C

GI  
MA  
EM  
LC  
EC  
FH  
CL  
MT  
AT  
PD  
FA  
RA  
BR  
ST  
RS  
BT  
HA  
ET  
HX



Body Front End

- When removing or installing hood, place a cloth or other padding on hood. This prevents vehicle body from being scratched.
- Bumper fascia is made of plastic. Do not use excessive force and be sure to keep oil away from it.
- Hood adjustment: Adjust at hinge portion.
- Hood lock adjustment: After adjusting, check hood lock control operation. Apply a coat of grease to hood locks engaging mechanism.
- Hood opener: Do not attempt to bend cable forcibly. Doing so increases effort required to unlock hood.

REMOVAL — Front bumper assembly

- 1 Remove bolts securing bumper fascia to engine undercover.
- 2 Remove screws and clips (C203) securing left and right sides of front fender protector. Then remove the front fender protector.
- 3 Remove clips (CS101) securing front grille, then remove the front grille.
- 4 Remove clip (C205) securing bumper fascia bracket to hood lock stay A.
- 5 Remove screws located at wheel opening.
- 6 Remove the screw securing each side of front clearance lamp assembly, then remove the front clearance lamp assembly.
- 7 Remove the screw securing each side of front turn signal lamp assembly. Then remove the front turn signal lamp assembly.
- 8 Remove bolts securing each side of front fender bracket.
- 9 Remove nuts securing left and right front fenders to bumper fascia bracket B.
- 10 Remove nuts and bolts securing bumper assembly to front side member.
- 11 Extract bumper assembly.
- 12 Remove bolts securing bumper fascia bracket to bumper fascia.
- 13 Disassemble bumper fascia and bumper fascia bracket.

Body Front End (Cont'd)

SEC. 260-261-262-263- 620-623-630-650-747

Hood lock adjustment

- Adjust hood so that hood primary lock meshes at a position 1 to 1.5 mm (0.039 to 0.059 in) lower than fender.
- After hood lock adjustment, adjust bumper rubber.
- When securing hood lock, ensure it does not tilt. Striker must be positioned at the center of hood primary lock.
- After adjustment, ensure that hood primary and secondary lock operate properly.

Hood lock secondary latch hooking length

More than 5.0 mm (0.197 in)

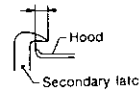

Bumper rubber adjustment

- Adjust so that hood is aligned with fender. At that time deflection is approx. 2 mm (0.08 in).
- [Bumper rubber free height is approx. 13 mm (0.51 in).]

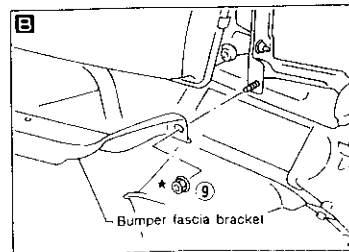
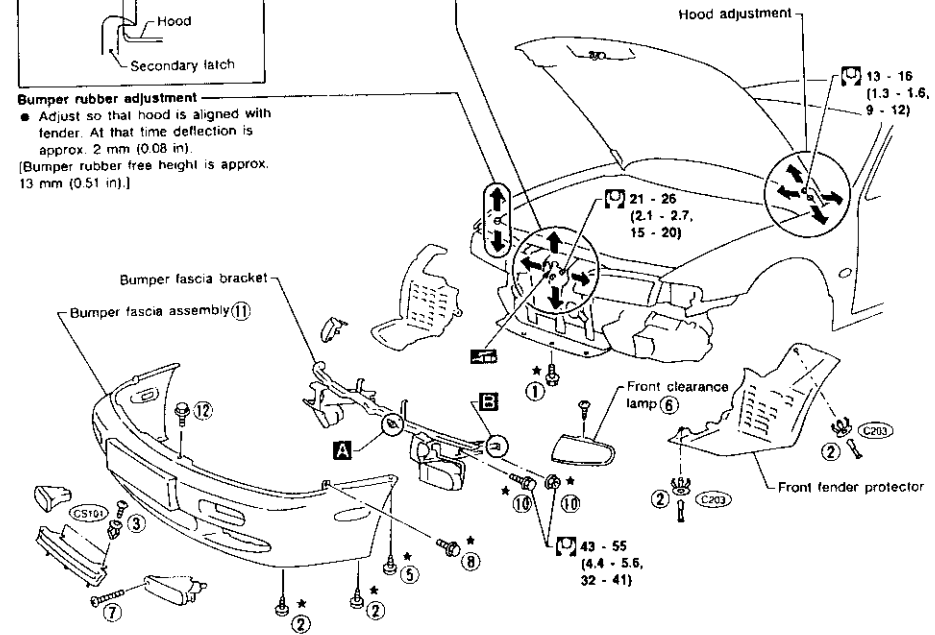
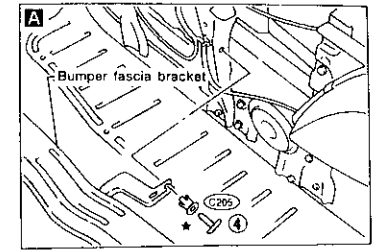

\* Bumper assembly mounting bolts, nuts and clips  
N·m (kg·m, ft·lb)

## BODY END

### Body Rear End and Opener

When removing or installing trunk lid, place a cloth or other padding on trunk lid. This prevents vehicle body from being scratched.

Trunk lid adjustment: Adjust at hinge-trunk lid portion for proper trunk lid fit.

Trunk lid lock system adjustment: Adjust striker so that it is in the center of the lock. After adjustment, check trunk lid lock operation.

Opener cable: do not attempt to bend cable using excessive force.

After installation, make sure that trunk lid and fuel filler lid open smoothly.

#### NOVAL — Rear bumper assembly

Remove trunk trim. Refer to "TRUNK ROOM TRIM" in "INTERIOR TRIM" for details. (BT-21)

Remove clips (CS101) securing rear panel upper to bumper fascia.

Remove clips (CS101) securing rear panel lower to bumper fascia.

Remove bolts from lower side of each side bumper.

Working inside trunk, remove nuts securing left and right rear fenders to bumper fascia (C).

Extract bumper assembly (H).

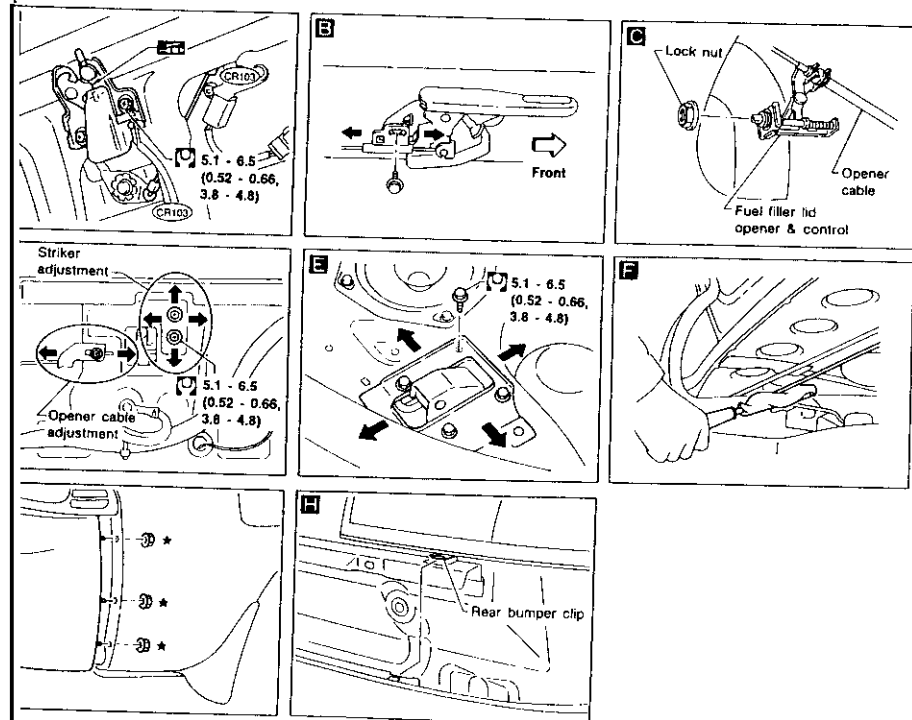

N·m (kg·m, ft·lb)

BT-8

## BODY END

### Body Rear End and Opener (Cont'd)

SEC. 843-850

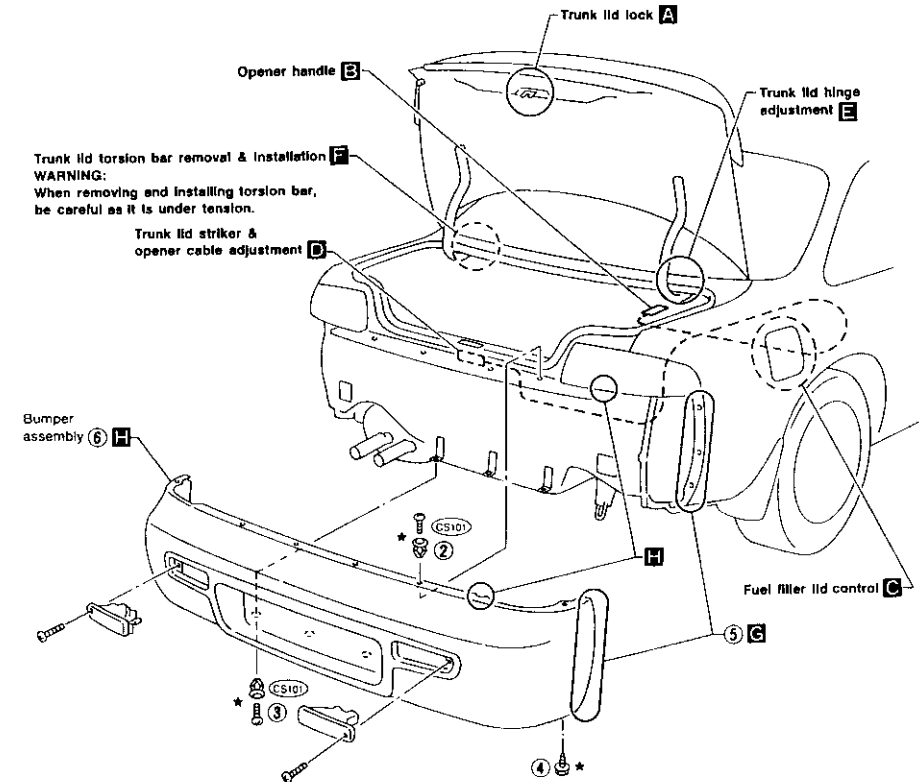

\* Bumper assembly mounting bolts, nuts and clips

BT

MBF528B

BT-9



## DOOR

- For removal of door trim, refer to "DOOR TRIM" in "INTERIOR TRIM" for details (BT-19).
- After adjusting door or door lock, check door lock operation.

SEC. 800-803-805

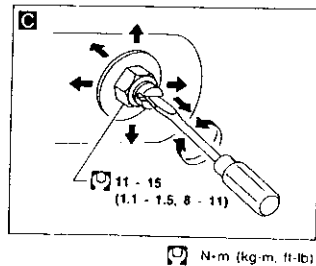
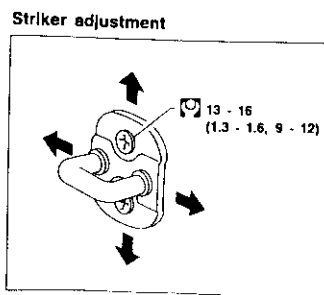
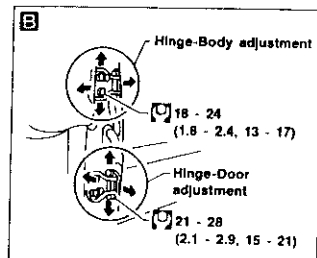
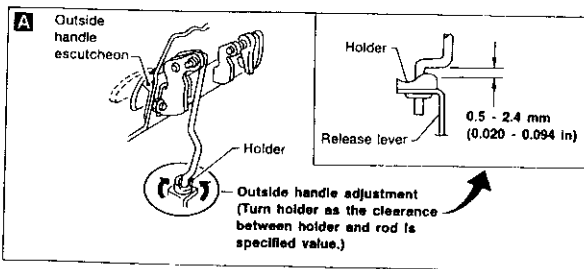
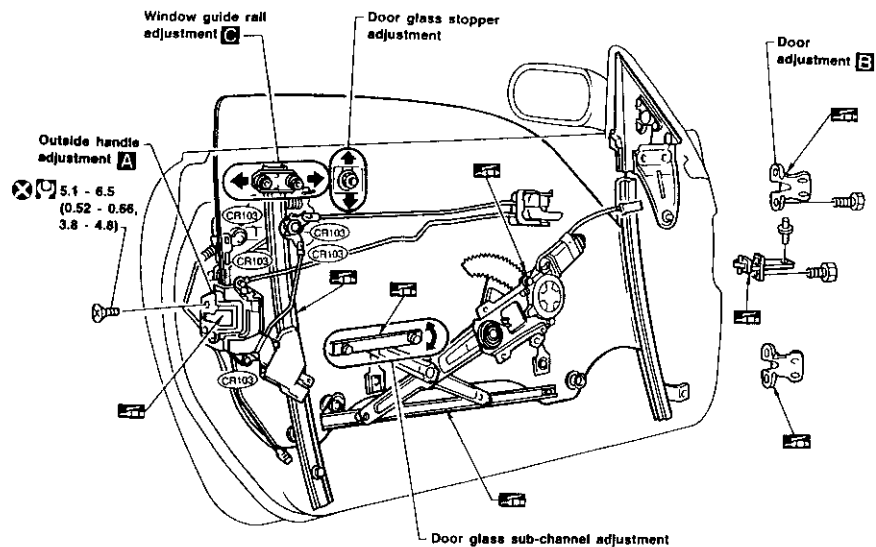

MBT042A

BT-10

## DOOR

### Door Glass Fitting Adjustment

The door glass is properly adjusted using the following five methods:

- A** In-out adjustment (at the glass waist)
- B** Fore-aft tilt adjustment
- C** In-out tilt adjustment (at the glass upper stop)
- D** Up-stop adjustment
- E** Fore-aft adjustment

#### NOTICE:

When adjusting the door glass, it is not necessary to remove the outside door molding.

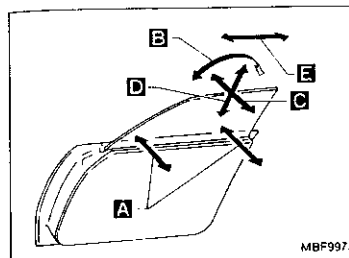

### Adjustment locations

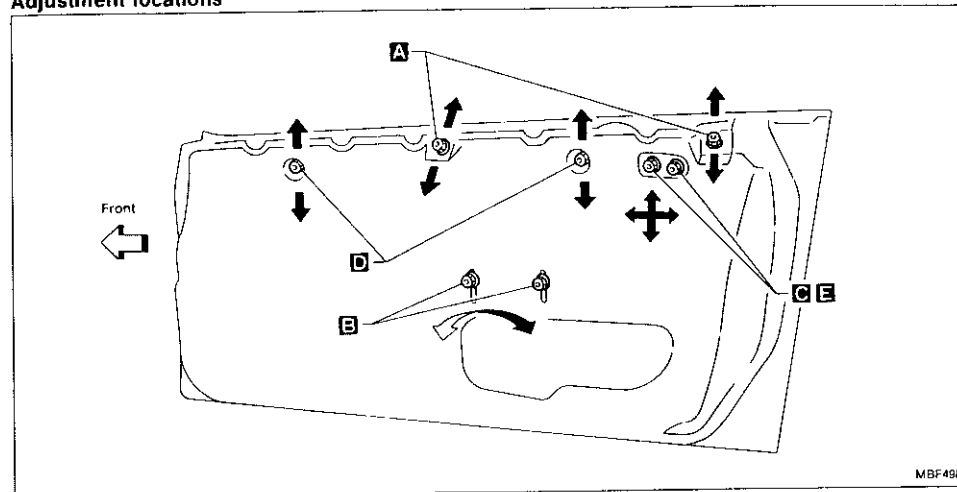

### Adjustment standard clearance

SEC. 803

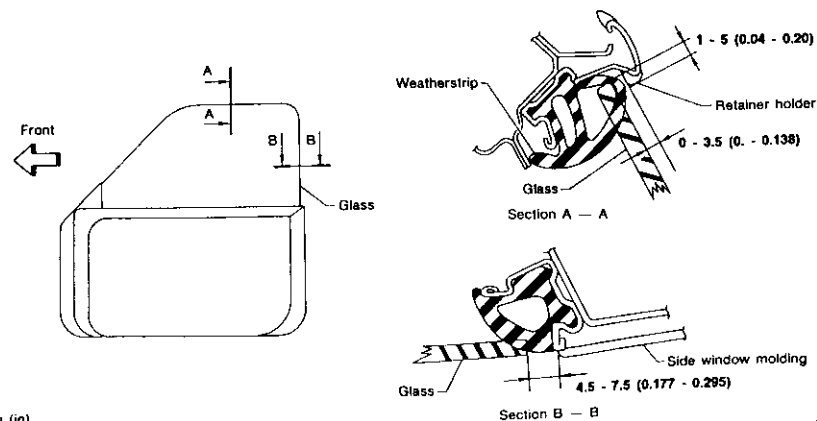

Unit: mm (in)

SBF394HA

BT-11

## DOOR

### Door Glass Fitting Adjustment (Cont'd)

#### A IN-OUT ADJUSTMENT (at the glass waist)

1. Raise door glass until glass stopper is in contact with inner stabilizer, just before the window stops.
2. Loosen adjusting bolts.
3. Lightly press door glass upper end outward so that glass outer surface contacts outer stabilizer. With glass held in that position, press inner stabilizer to glass inner surface and tighten adjusting bolt.

#### CAUTION:

Make sure nap portions of stabilizers are clean and free from oil, grease, etc.

#### B FORE-AFT TILT ADJUSTMENT

- Adjust door glass sub-channel so that the adjustment standard clearances A - A and B - B (Refer to BT-11) are obtained at the glass and retainer holder/body side weatherstrip locations.

- For sub-channel adjustment procedures, refer to figure at left as a guide.

#### CAUTION:

- Make sure door glass sub-channel is horizontal.
- The fore-aft tilt adjustment must be made at the same time the fore-aft adjustment **E** is made.

#### C IN-OUT TILT ADJUSTMENT (at glass upper stop)

1. Adjust door glass-to-holder clearance to 0 to 3.5 mm (0 to 0.138 in) (A) with the adjusting bolts.

#### CAUTION:

- Turn adjusting bolt clockwise to move door glass upper end outward.
- Turn adjusting bolt counterclockwise to move door glass upper end inward.

- For sub-channel adjustment procedures, refer to figure at left as a guide.

#### CAUTION:

- Make sure door glass sub-channel is horizontal.
- The fore-aft tilt adjustment must be made at the same time the fore-aft adjustment **E** is made.

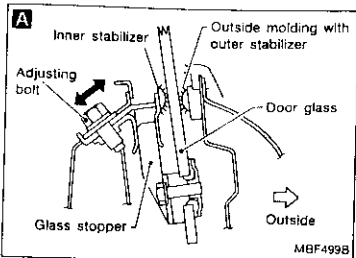

MBF499B

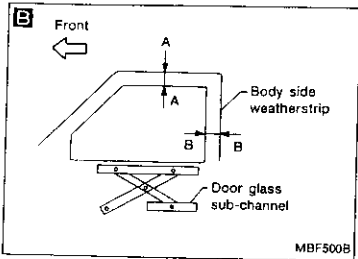

MBF500B

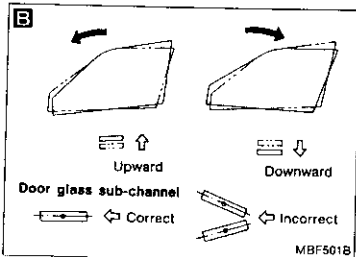

MBF501B

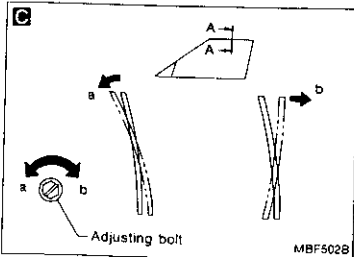

MBF502B

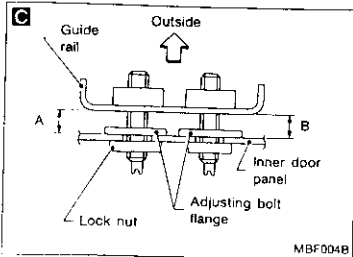

MBF004B

## DOOR

### Door Glass Fitting Adjustment (Cont'd)

#### D UP-STOP ADJUSTMENT

1. Adjust panel stopper height so that clearance at upper edge of door meets the adjustment standard clearance A - A (Refer to BT-11). Make sure front and rear glass stoppers lightly contact front and rear panel stoppers, then tighten adjusting nuts.
2. If stoppers do not contact each other, adjust sub-channel nut. Refer to "B Fore-aft tilt adjustment".
3. Open and close doors to make sure upper end of door glass does not contact holder.

#### E FORE-AFT ADJUSTMENT

1. Adjust guide rail in the fore-aft direction so that when door is closed or opened the clearance between upper edge of door glass and holder conforms to the adjustment standard clearance A - A (Refer to BT-11).
2. If outer perimeter of door glass interferes with holder when door is opened or closed, refer to "B Fore-aft tilt adjustment" for procedures.

#### CAUTION:

When loosening guide rail lock nut, prevent adjusting bolt from turning by holding it with a standard screwdriver.

3. Lower the glass slightly until the glass side stopper comes off the panel side stopper.

#### CAUTION:

Do not lower the glass excessively.

- After completing door glass adjustment, retighten all lock nuts.

#### CAUTION:

While tightening lock nuts, hold adjusting bolts using a standard screwdriver to prevent them from turning.

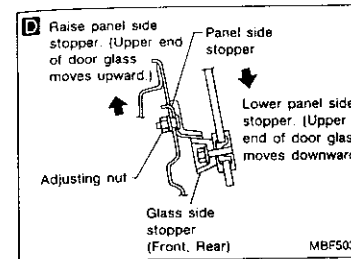

MBF503B

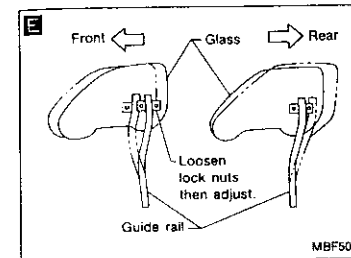

MBF504B

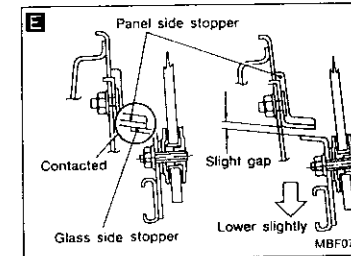

MBF079B

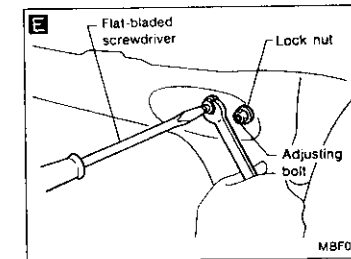

MBF080A

GI  
MA  
EM  
LC  
EC  
FE  
CL  
MT  
AT  
PD  
FA  
RA  
BR  
ST  
RS  
BT  
HA  
EL  
DX

# INSTRUMENT PANEL

487-680-685-969

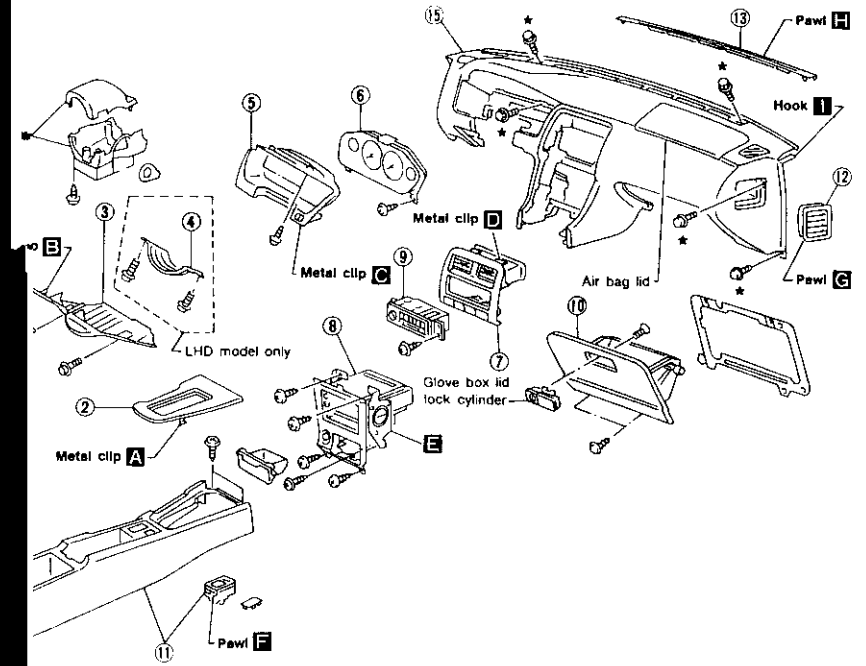

Instrument panel assembly mounting bolts and nuts

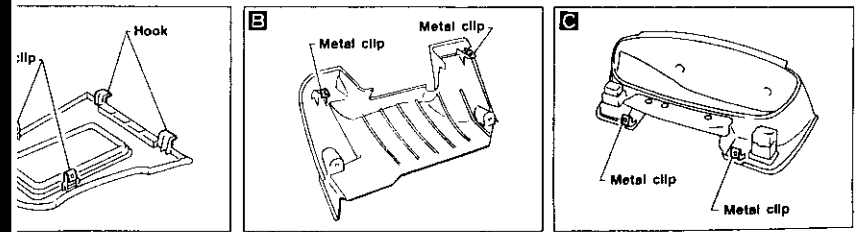

GT  
MA  
EM  
LC  
EC  
FE  
CL  
MT  
AY  
PD  
FA  
RA  
BR  
ST  
RS  
BT  
HA  
EL  
EDX

## INSTRUMENT PANEL

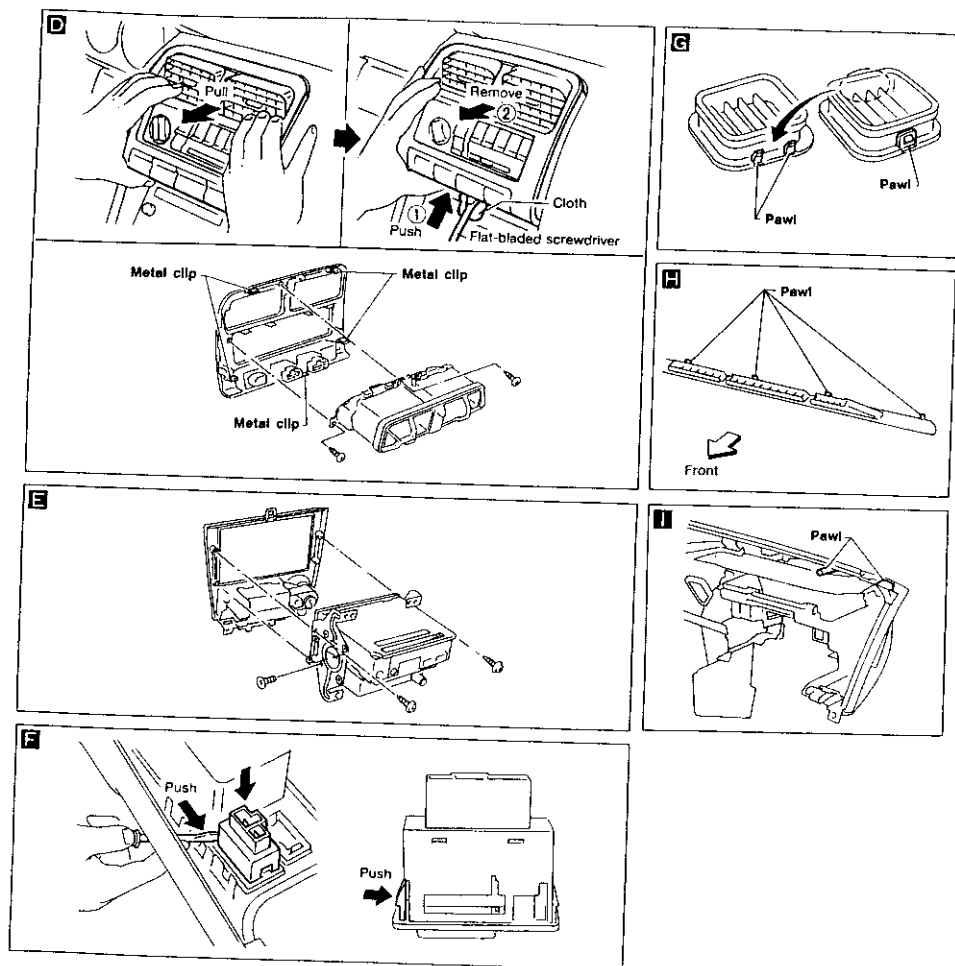

BT-16

MBF529B

## INTERIOR TRIM

### SIDE AND FLOOR TRIM

#### CAUTION:

Wrap the tip of flat-bladed screwdriver with a cloth when removing metal clips from garnishes.

#### REMOVAL — Body side trim

- ① Remove front and rear seat. Refer to "SEAT" for details (BT-27).
- ② Remove dash side finisher.
- ③ Remove kicking plate.
- ④ Remove front pillar garnish.
- ⑤ Remove rear side finisher.
- ⑥ Remove rear pillar finisher.
- ⑦ Remove rear parcel shelf.
- ⑧ Remove seat back finisher welt. Refer to "TRUNK ROOM TRIM" for details (BT-21).
- ⑨ Remove seat back finishers (Right, Center, Left).

GI  
MA  
EM  
LC  
EC  
FE  
CL  
WT  
AY  
PD  
FA  
BA  
BR  
ST  
AS  
BT  
HA  
EL  
IDX

BT-17

## INTERIOR TRIM

SEC. 678-749-769-799-809

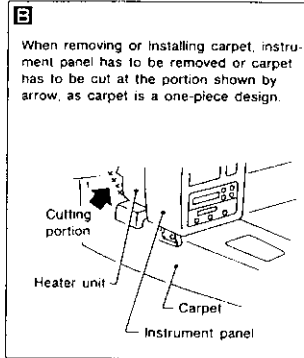
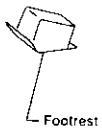
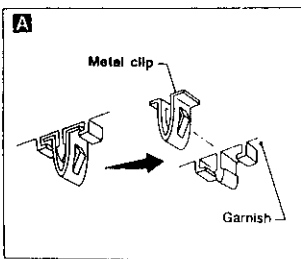
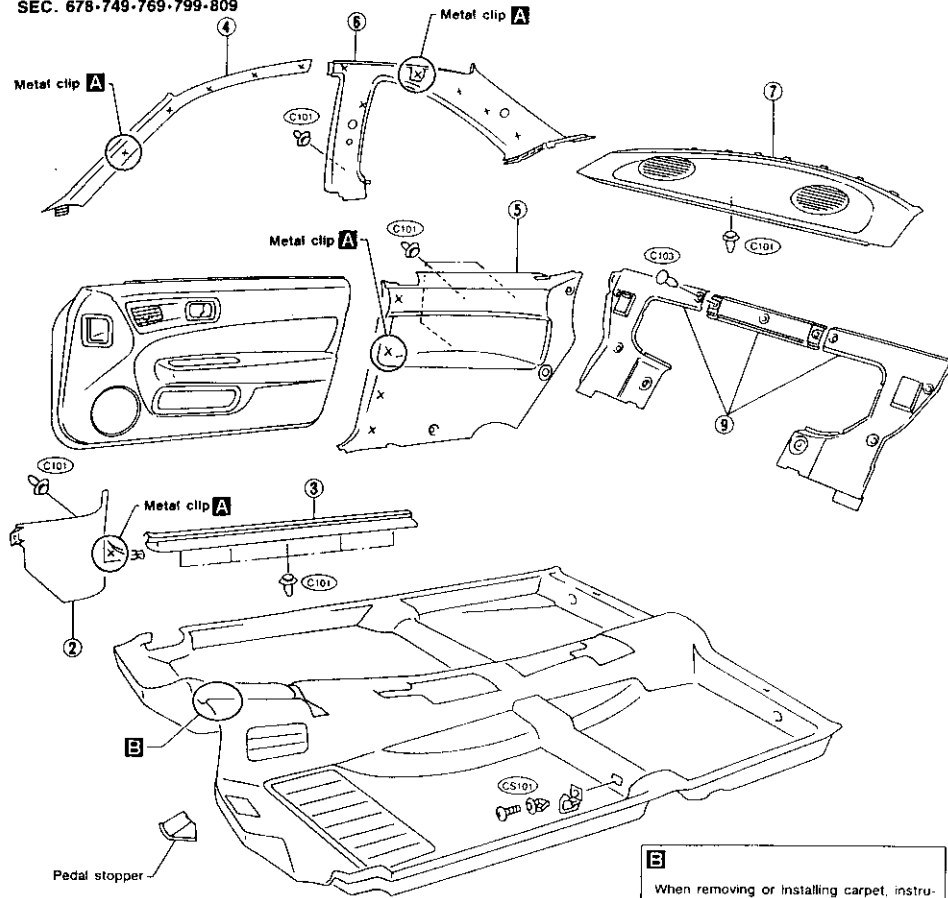

MBF445BA

BT-18

## INTERIOR TRIM

### DOOR TRIM

#### REMOVAL — Door trim

- ① Remove screws securing inside handle escutcheon, then remove the inside handle escutcheon **A**.
- ② Remove power window switch **B**.
- ③ Remove screws securing door finisher.
- ④ Remove clips **(C103)** securing door finisher.
- ⑤ Pull door finisher to remove clips **(C101)** and metal clips **C** from door panel and remove door finisher. Disconnect harness connectors.
- ⑥ Remove ventilator grille and ventilator duct assembly from door finisher **D**.

SEC. 809

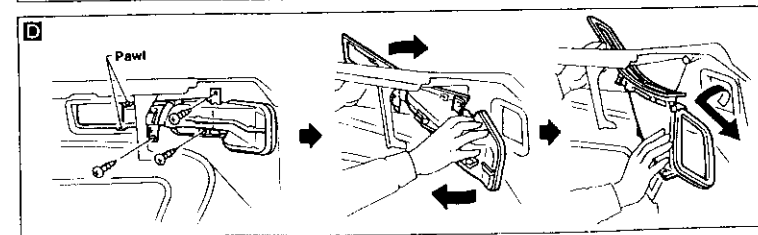
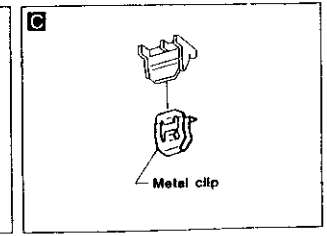
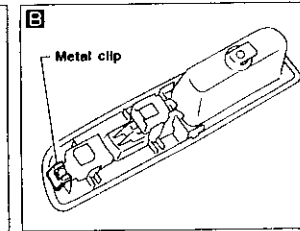
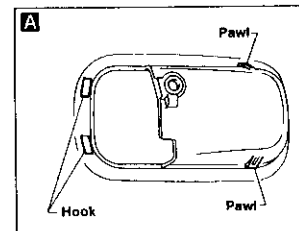
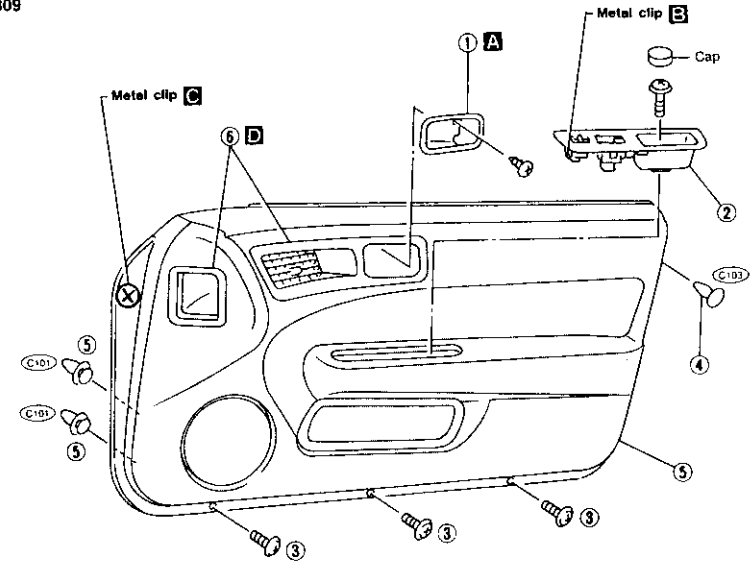

MBF4478A

BT-19

## INTERIOR TRIM

### ROOF TRIM

#### REMOVAL — Headlining

- ① Remove rear seat. Refer to "Rear Seat" for details (BT-30).
- ② Remove seat belt adjuster cover over anchor bolt.
- ③ Remove front and rear seat belts. Refer to "Seat Belt" in RS section for details.
- ④ Remove body side trim. Refer to "SIDE AND FLOOR TRIM" for details (BT-17).
- ⑤ Remove sunroof switch **A**.
- ⑥ Remove inside mirror assembly.
- ⑦ Remove sun visors **B**.
- ⑧ Remove interior lamp assembly.
- ⑨ Remove sunroof welt **C**.
- ⑩ Remove clips **C103** securing each side of headlining.
- ⑪ Remove metal clips securing headlining **D**.
- ⑫ Remove headlining.

SEC. 738-963-964

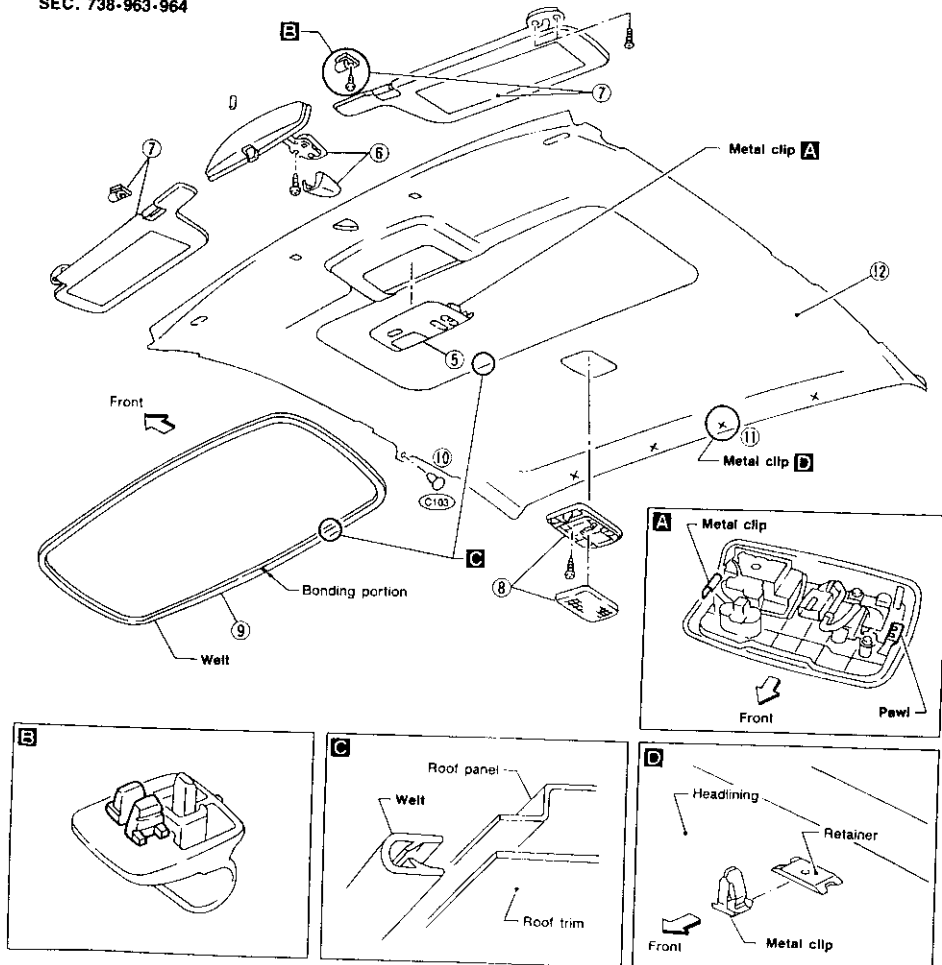

BT-20

MBF446BA

## INTERIOR TRIM

### TRUNK ROOM TRIM

SEC. 799-849

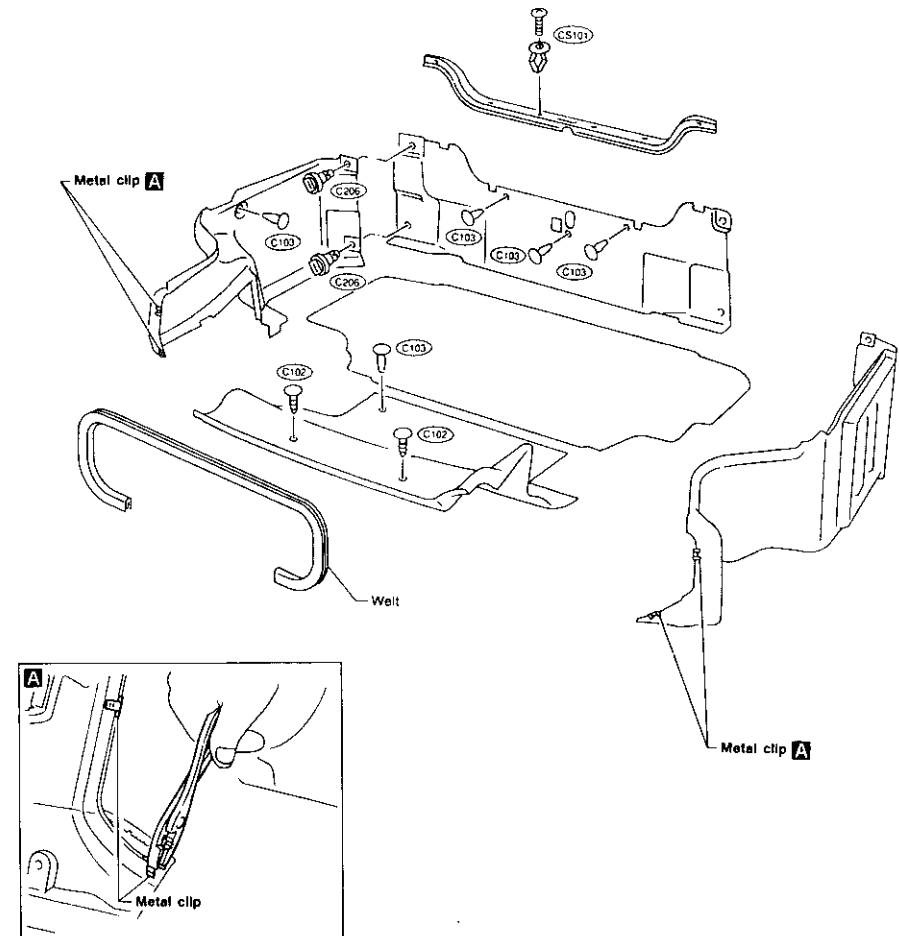

MBF448BA

BT-21

GI  
VA  
EV  
LC  
EC  
FR  
CL  
MT  
AT  
PB  
FA  
HA  
BR  
ST  
BS  
BT  
HA  
ET  
TOM

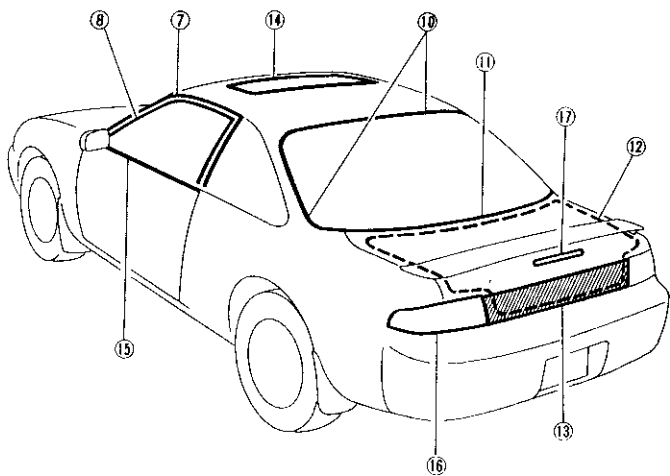
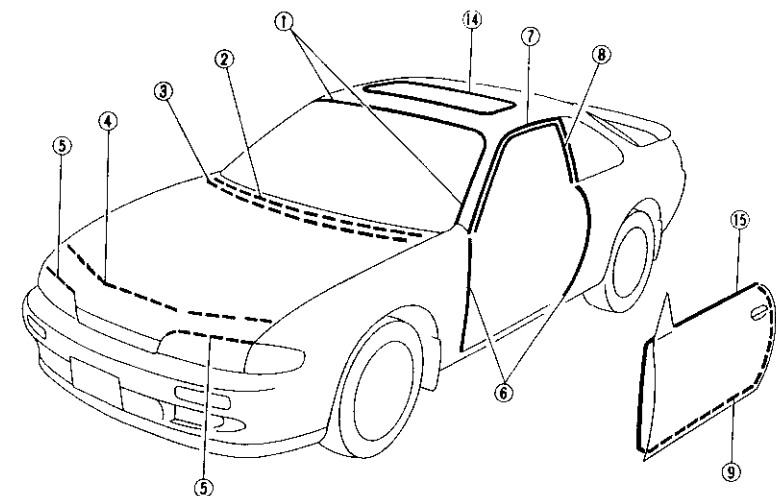

MBF449B

① Windshield upper and side molding

Method 1

Cut off top portion of molding and clean glass and panel surfaces.

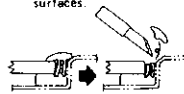

Apply sealant to top portion of molding.



Cut off lower portion of new molding.



Finish well to give it a good appearance.

Method 2

1. Cut off sealant at glass end.
2. Clean the side on which panel was mounted.
3. Set molding fastener and apply sealant to body panel, and apply primer to molding and body.

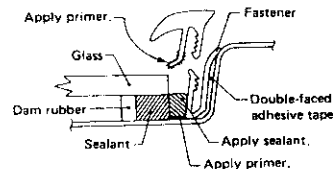

4. Install molding by aligning the molding mark located on center with vehicle center. Be sure to install tightly so that there is no gap around the corner.

SBF161F

②, ③ Cowl top grille and hood rear sealing rubber

SEC. 660

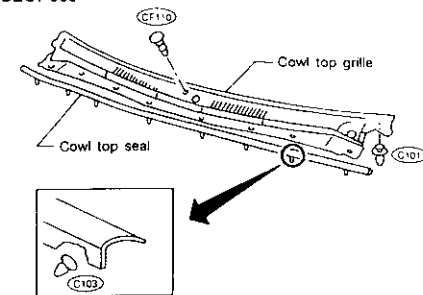

MBF450B

④, ⑤ Hood front sealing rubber

SEC. 650

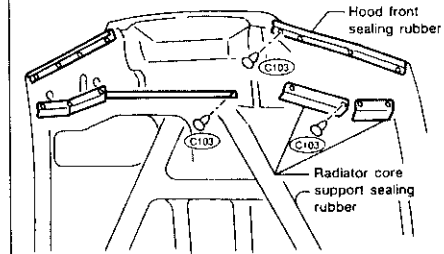

MBF451B

⑥ Body side well

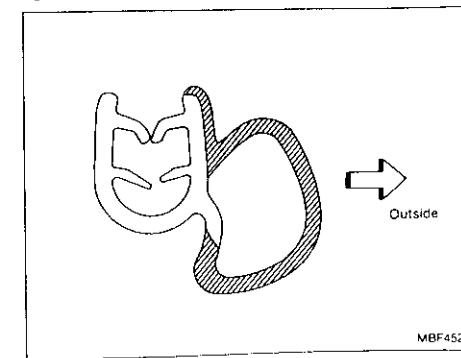

MBF452B

## EXTERIOR TRIM

### ⑦, ⑧ Body side weatherstrip and weatherstrip retainer

SEC. 766

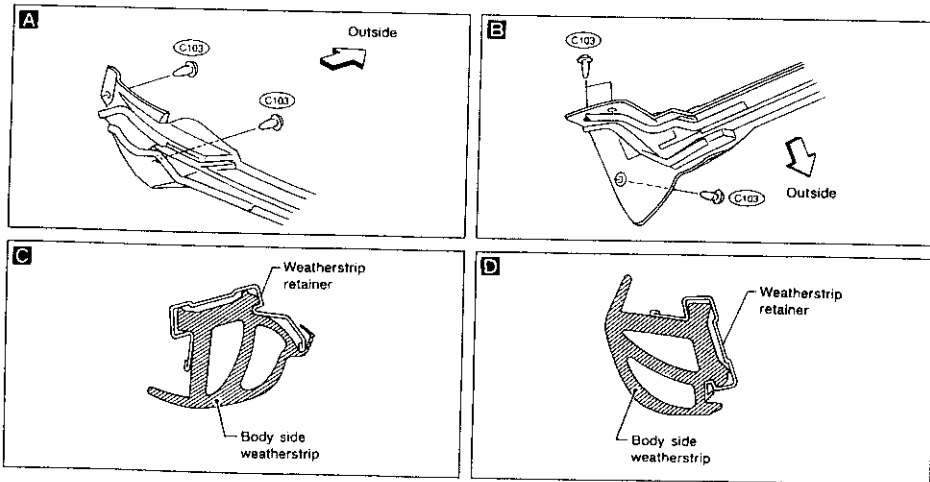
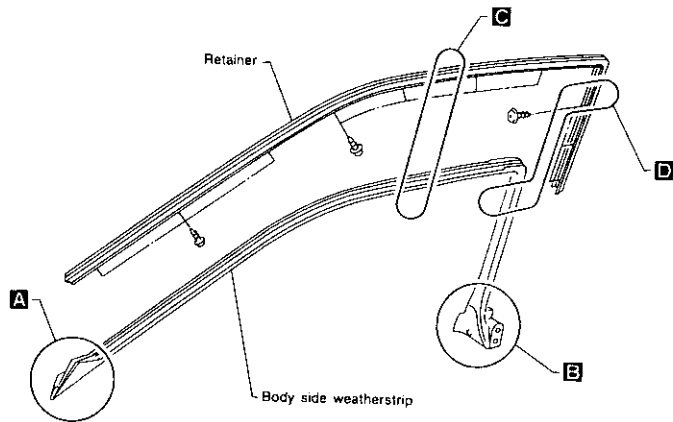

MBF453BA

## EXTERIOR TRIM

### ⑨ Door weatherstrip

Before removing door weatherstrip, remove door trim. Refer to "DOOR TRIM" for details (BT-19).

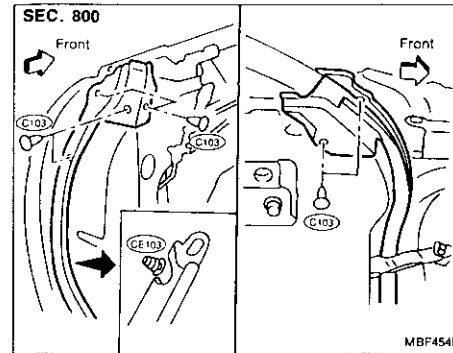

### ⑩ Back window upper and side molding (SEC. 797)

Basically the same as windshield upper and side molding.

### ⑪ Back window lower molding (SEC. 797)

It is mounted with screws.

### ⑫ Trunk lid weatherstrip

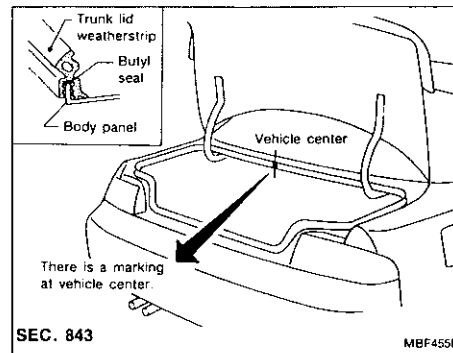

### ⑬ Rear panel finisher

SEC. 265

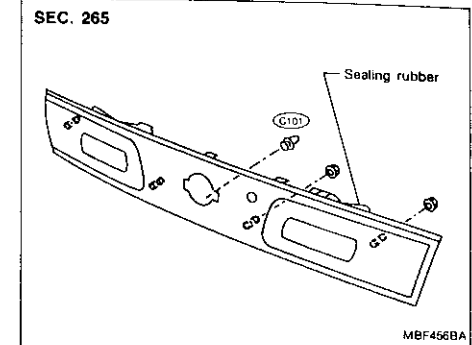

### ⑭ Sun roof lid weatherstrip

SEC. 736

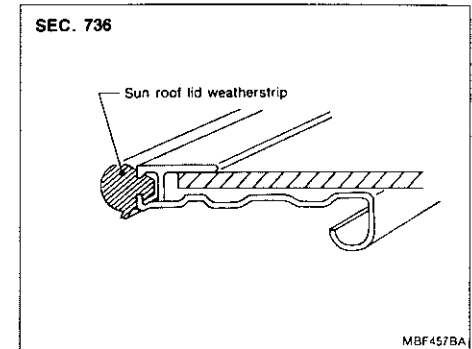

### ⑮ Door waist outside molding

SEC. 800

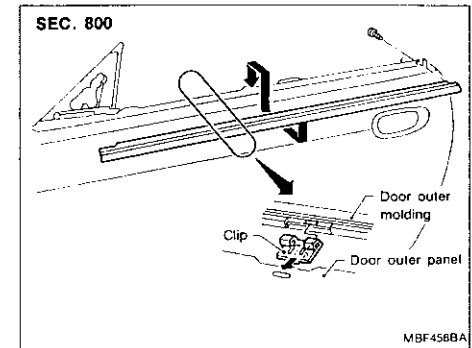



## EXTERIOR TRIM

### 16 Rear combination lamp

SEC. 265

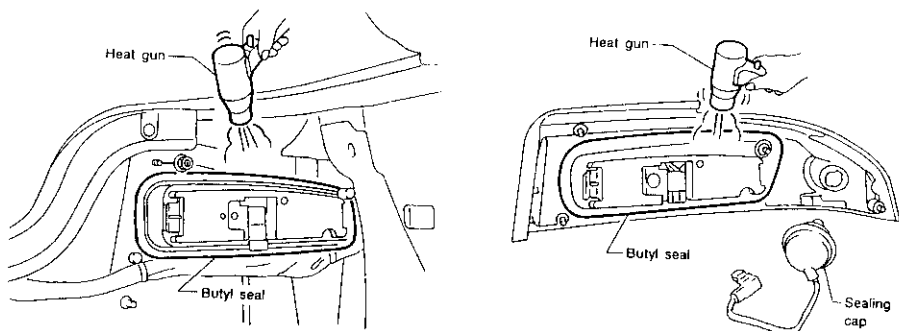

- Warm up lamp assembly area to a temperature a little below 60°C (140°F).

- Apply butyl seal evenly as it tends to become thin in the corners.
- Warm up lamp assembly area to a temperature a little below 60°C (140°F).

MBF459B

### 17 High-mounted stop lamp

SEC. 268

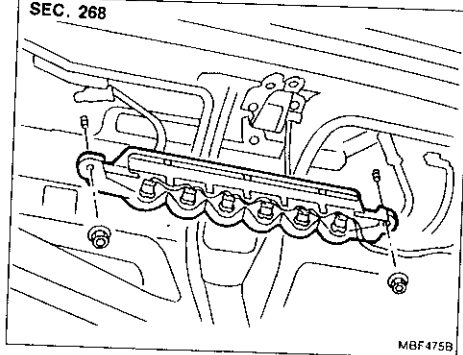

MBF475B

BT-26

## SEAT

- When removing or installing the seat trim, carefully handle it to keep dirt out and avoid damage.

### Front Seat

SEC. 870

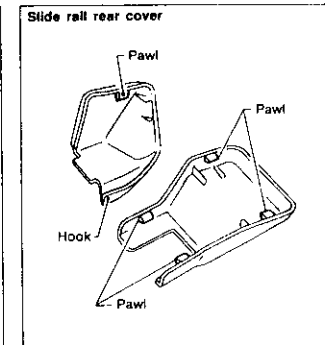
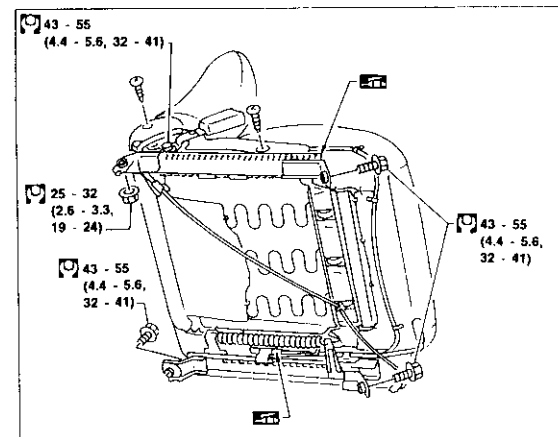
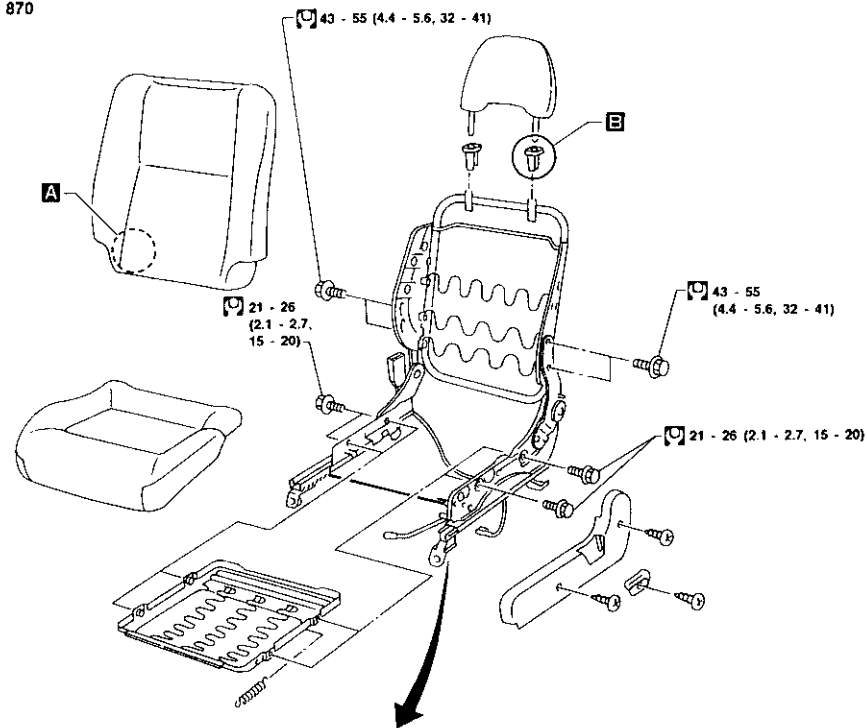

N·m (kg·m, ft·lb)

BT-27

MBF460BA

GI  
MA  
EM  
LC  
EC  
EE  
CL  
MT  
AT  
PD  
FA  
RA  
BR  
ST  
PS  
BT  
HA  
EL  
FOX

## SEAT

### Front Seat (Cont'd)

Remove retainer from lower side of seatback with fingers.

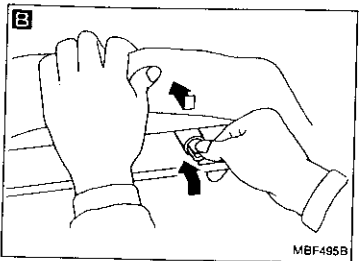
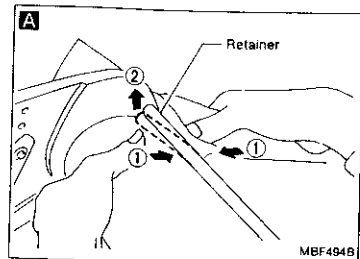

Roll up seatback trim all the way to gain access to headrest holder pawls. Disengage and push headrest holder pawls to unlock holder. Lift off headrest holder.

## SEAT

### Front Seat (Cont'd)

#### HEATED SEAT

- When handling seat, be extremely careful not to scratch heating unit.
- To replace heating unit, seat trim and pad should be separated.
- Do not use any organic solvent, such as thinner, benzene, alcohol, gasoline, etc. to clean trims.

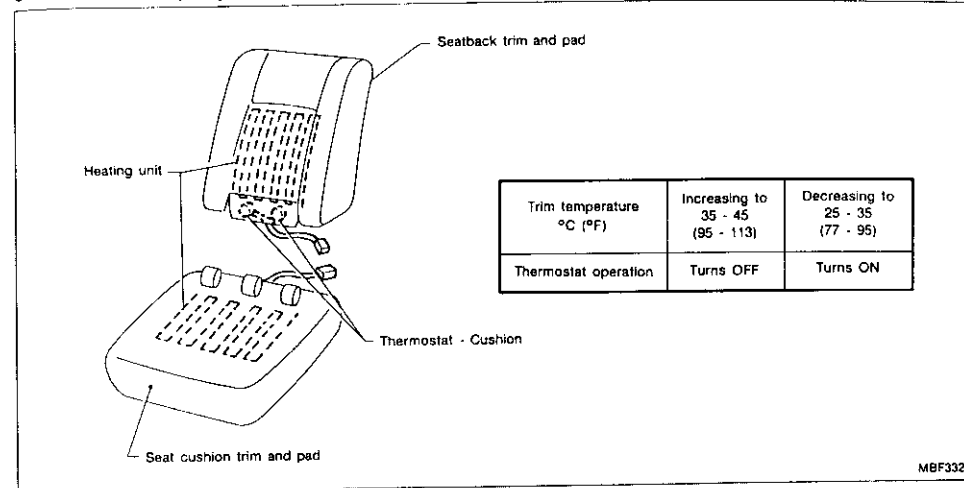

★ For Wiring Diagram, refer to "HEATED SEAT" in EL section.

GI  
MA  
EM  
LC  
EC  
FE  
CL  
MT  
AT  
PD  
FA  
BA  
BR  
ST  
RS  
BT  
HA  
EL  
EDX

## SEAT

### Rear Seat

SEC. 880

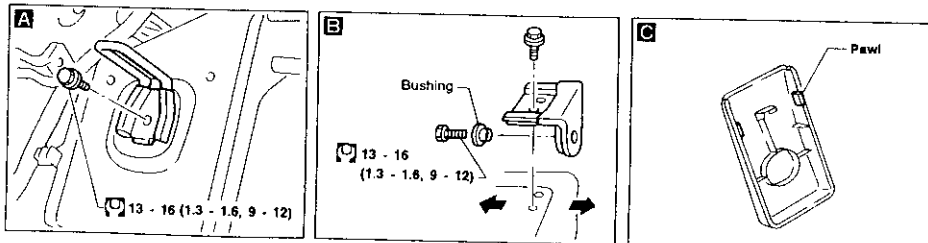
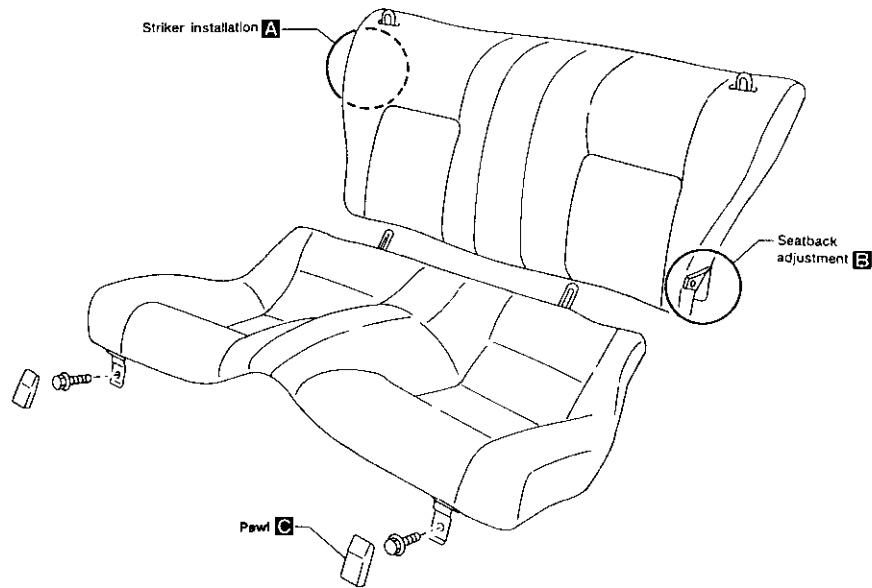

N·m (kg·m, ft·lb)

BT-30

## SUN ROOF

★ For Wiring Diagram, refer to "ELECTRIC SUN ROOF" in EL section.

### ADJUSTMENT

Install motor & limit SW assembly and sunroof rail assembly in the following sequence:

1. Arrange equal lengths of link and wire assemblies on both sides of sunroof opening.
2. Connect sunroof connector to sunroof switch and positive (+) power supply.
3. Set lid assembly to fully closed position **A** by operating OPEN switch and TILT switch.
4. Fit outer side of lid assembly to the surface of roof on body outer panel.
5. Remove motor, and keep OPEN switch pressed until motor pinion gear reaches the end of its rotating range.
6. Install motor.
7. Check that motor drive gear fits properly in wires.
8. Press TILT-UP switch to check lid assembly for normal tilting.
9. Check sunroof lid assembly for normal operations (tilt-up, tilt-down, open, and close).

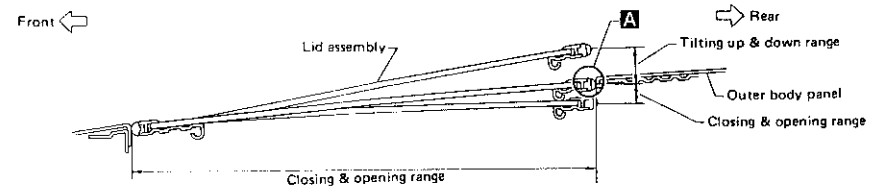

SBF920F

BT-31

GI

WA

EM

LC

EC

FE

CL

MT

AT

PD

FA

RA

BR

ST

RS

**BT**

WA

EL

EOX

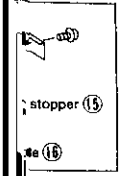

assembly



assembly

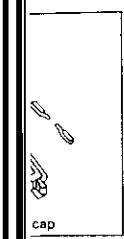

GI

MA

EM

LC

EC

FE

CI

MT

AT

PO

FA

WA

BR

ST

BS

**BT**

RA

RI

TRC

## SUN ROOF

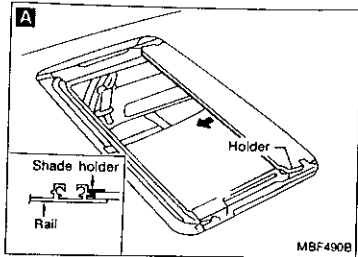

- A** Using flat-bladed screwdriver, pry shade assembly holder off rail. Then pull shade assembly forward to remove it from rail.

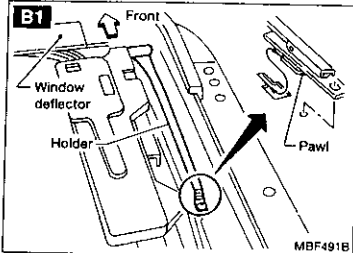

- B1** Disengage pawls from rail, then remove window deflector holder.

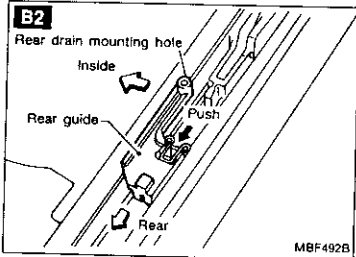

- B2** Using flat-bladed screwdriver, pry stopper spring off rail groove. Then slide rear guide backward to remove it from rail.

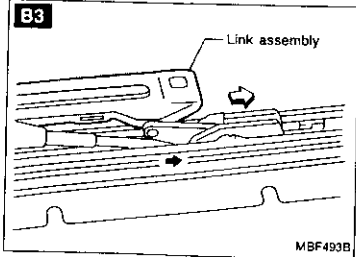

- B3** Remove wire and link assembly from rail while pushing link back with flat-bladed screwdriver.

## WINDSHIELD AND WINDOWS

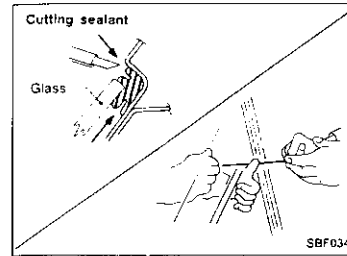

### REMOVAL

After removing moldings, remove glass.

#### CAUTION:

Be careful not to scratch glass when removing.

### INSTALLATION

- Use genuine Nissan Sealant kit or equivalent. Follow instructions furnished with it.
- After installation, the vehicle should remain stationary until the sealant hardens.

#### WARNING:

Keep heat and open flames away as primers are flammable. CAUTION:

Advise users not to drive the vehicle on rough roads until sealant has properly vulcanized.

- Do not use sealant which is past its usable term.
- Do not leave cartridge unattended with its cap open.
- Keep primers and sealant in a cool, dry place. Ideally, they should be stored in a refrigerator.
- Molding must be installed securely so that it is in position and leaves no gap.

### Windshield and Rear Window

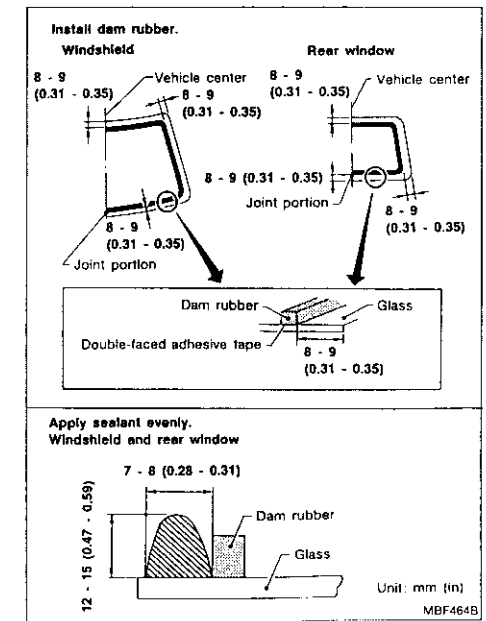
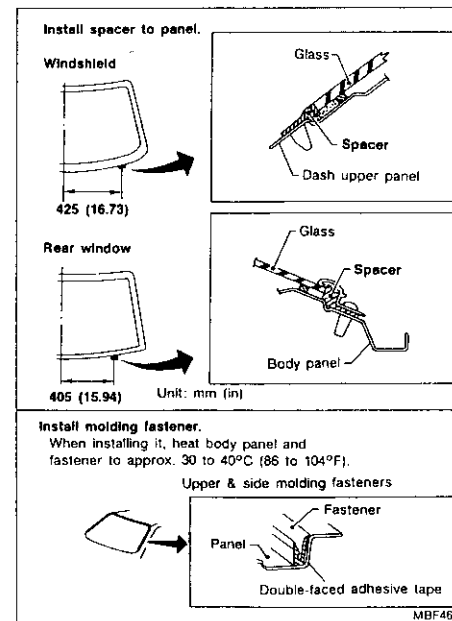

### REPAIRING WATER LEAKS FOR WINDSHIELD AND WINDOWS

Leaks can be repaired without removing and reinstalling glass.

If water is leaking between caulking material and body or glass, determine the extent of leaking. This can be determined by applying water while pushing glass outward.

To stop the leak, apply primer and then sealant to the leak point.

## DOOR MIRROR

Wiring Diagram, refer to "POWER DOOR MIRROR" in EL section.

### CAUTION:

Be careful not to scratch door rearview mirror body.

### REMOVAL — Door mirror

Remove door trim. Refer to "DOOR TRIM" in "INTERIOR TRIM" for details (BT-19).

Remove inner cover front corner of door **A**.

Disconnect door mirror harness connector.

Remove harness clips.

Remove three bolts securing door mirror, then remove door mirror.

Fig. 963

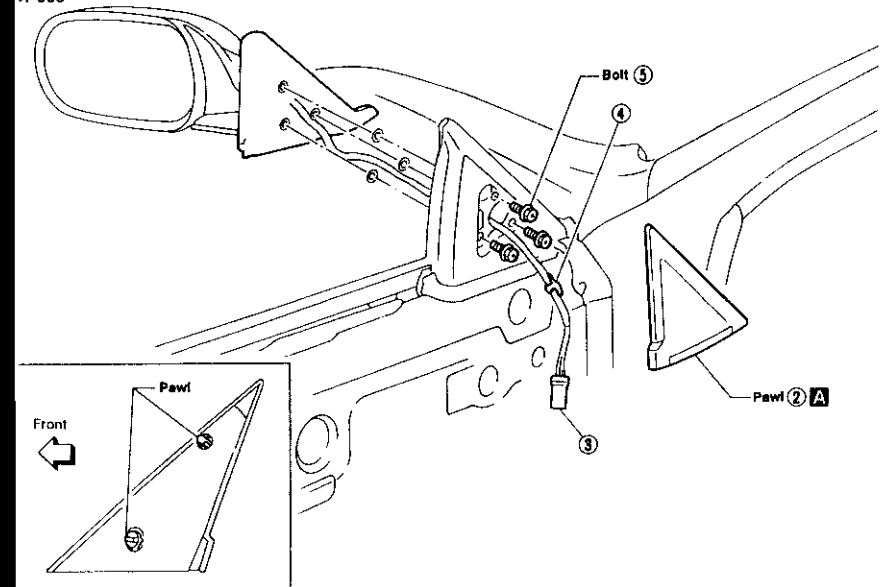

**Preparation:**  
Wrap flat-bladed of screwdriver with a cloth to prevent scratching rear of door mirror. Do not insert screwdriver too far.

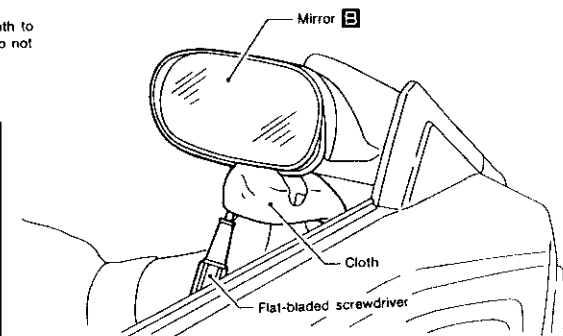
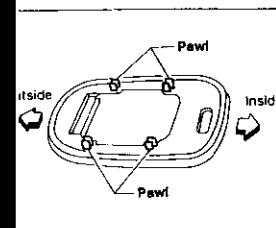

MBF466BA

GI  
MA  
EM  
LC  
EC  
FE  
CL  
MT  
AT  
PD  
FA  
BA  
NR  
BT  
RS  
BT  
HA  
EL  
FOX

## FRONT AND REAR AIR SPOILER

- When installing, make sure that there are not gaps or waves at ends of air spoiler.
- Before installing spoiler, clean and remove oil from surface where spoiler will be mounted.

### Front Air Spoiler

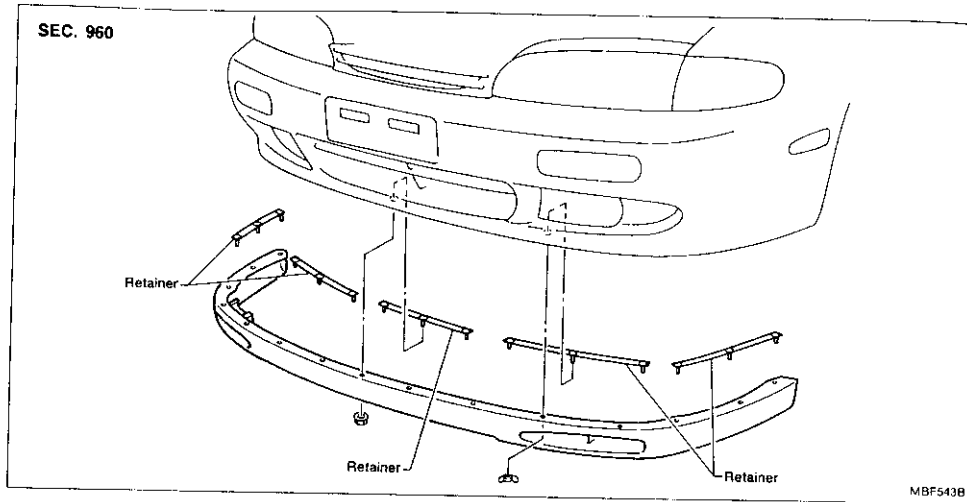

### Rear Air Spoiler

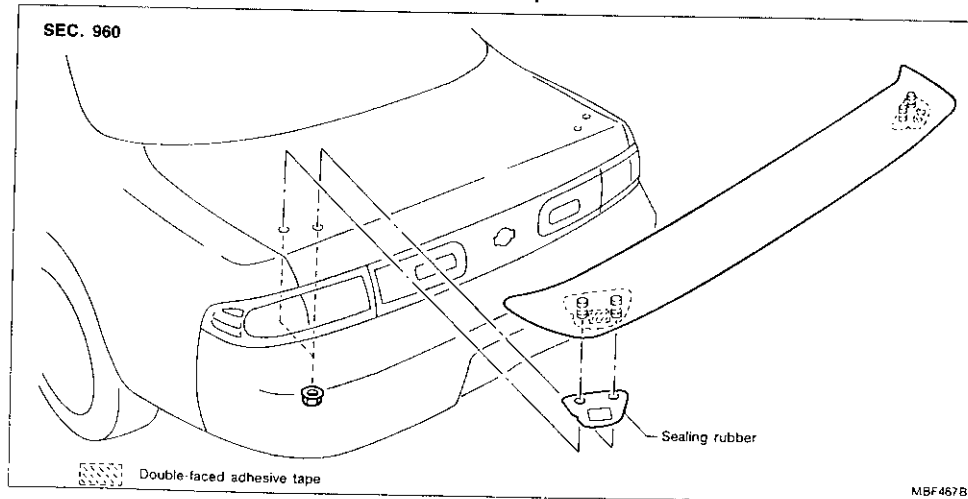

BT-38

## BODY ALIGNMENT

- All dimensions indicated in figures are actual ones.
- When using a tracking gauge, adjust both pointers to equal length. Check the pointers and gauge itself to make sure there is no free play.
- When a measuring tape is used, check to be sure there is no elongation, twisting or bending.
- Measurements should be taken at the center of the mounting holes.
- An asterisk (\*) following the value at the measuring point indicates that the measuring point on the other side is symmetrically the same value.
- The coordinates of the measurement points are the distances measured from the standard line of "X", "Y" and "Z".

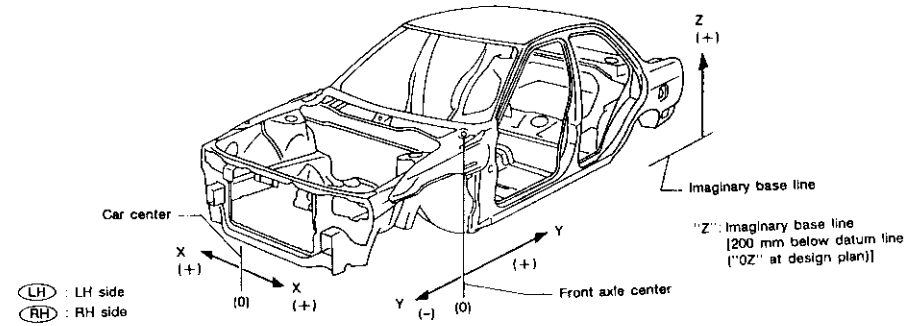

SBF874G

### Engine Compartment

## MEASUREMENT

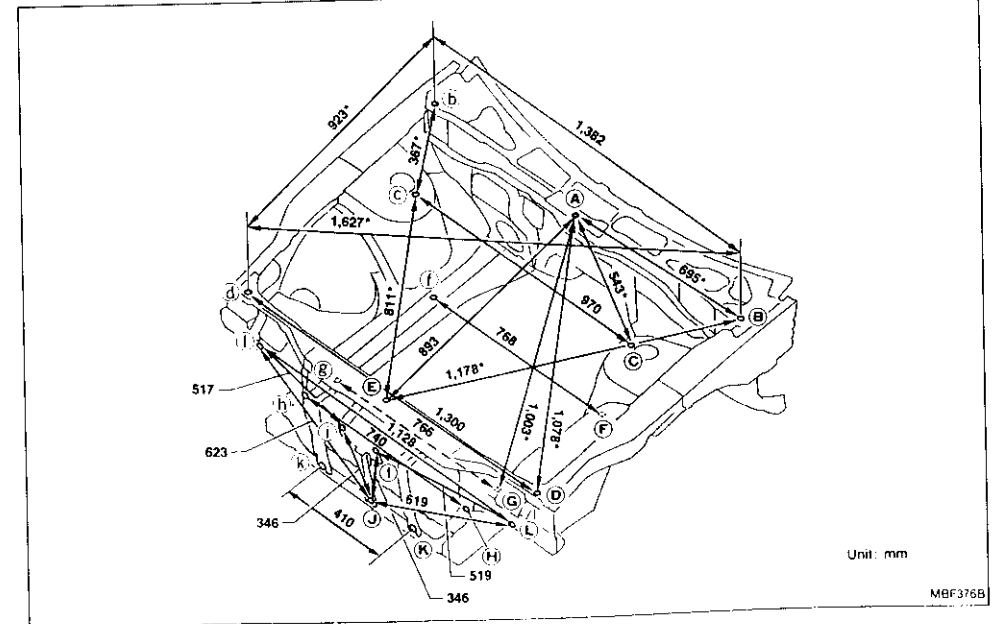

BT-39

# BODY ALIGNMENT

- All dimensions indicated in figures are actual ones.
- When using a tracking gauge, adjust both pointers to equal length. Check the pointers and gauge itself to make sure there is no free play.
- When a measuring tape is used, check to be sure there is no elongation, twisting or bending.
- Measurements should be taken at the center of the mounting holes.
- An asterisk (\*) following the value at the measuring point indicates that the measuring point on the other side is symmetrically the same value.
- The coordinates of the measurement points are the distances measured from the standard line of "X", "Y" and "Z".

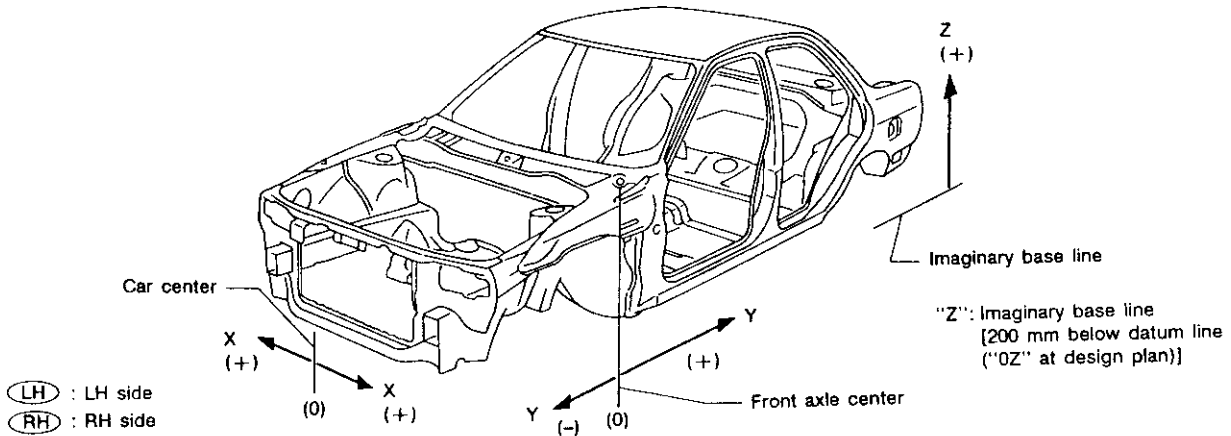

## Engine Compartment

SBF874G

### MEASUREMENT

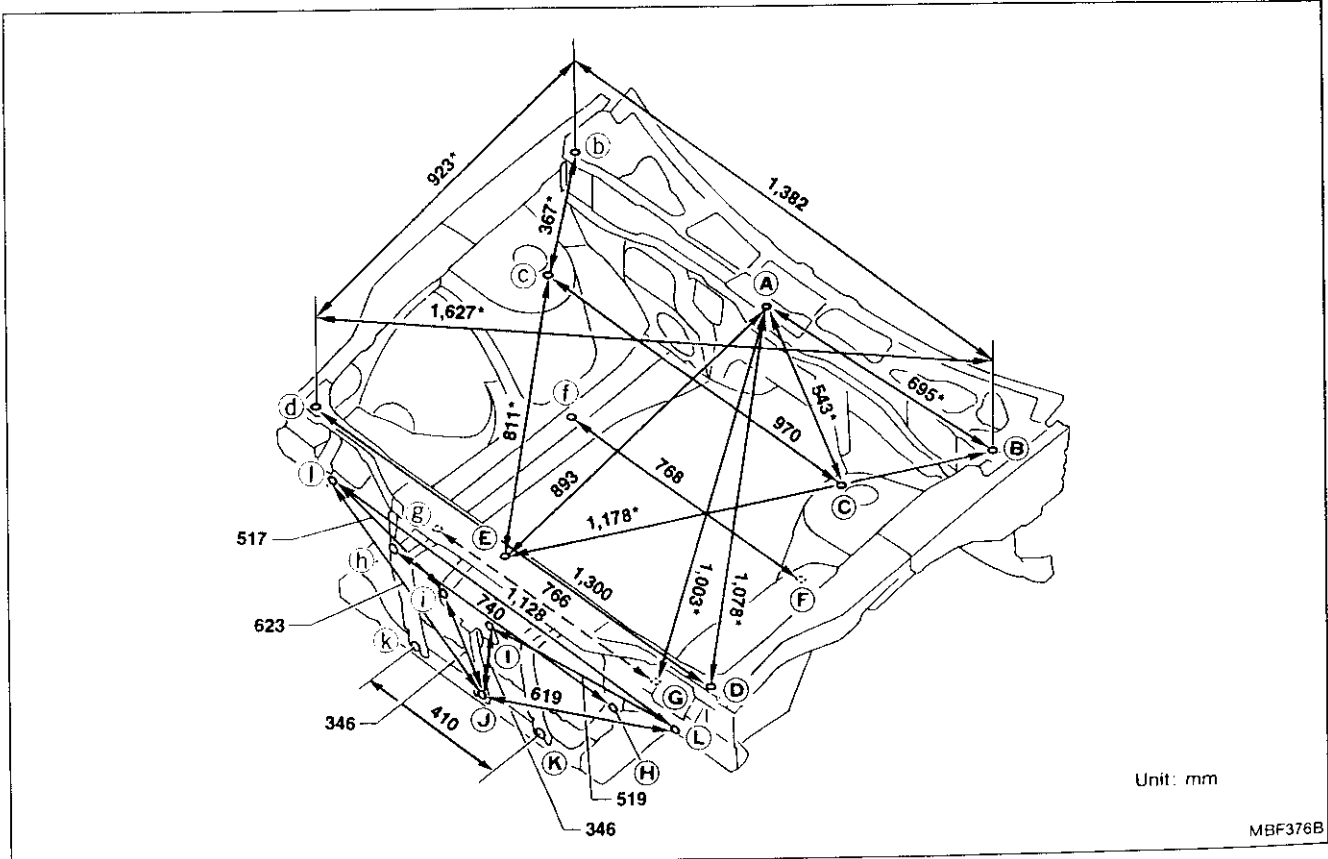



## FRONT AND REAR AIR SPOILER

- When installing, make sure that there are not gaps or waves at ends of air spoiler.
- Before installing spoiler, clean and remove oil from surface where spoiler will be mounted.

### Front Air Spoiler

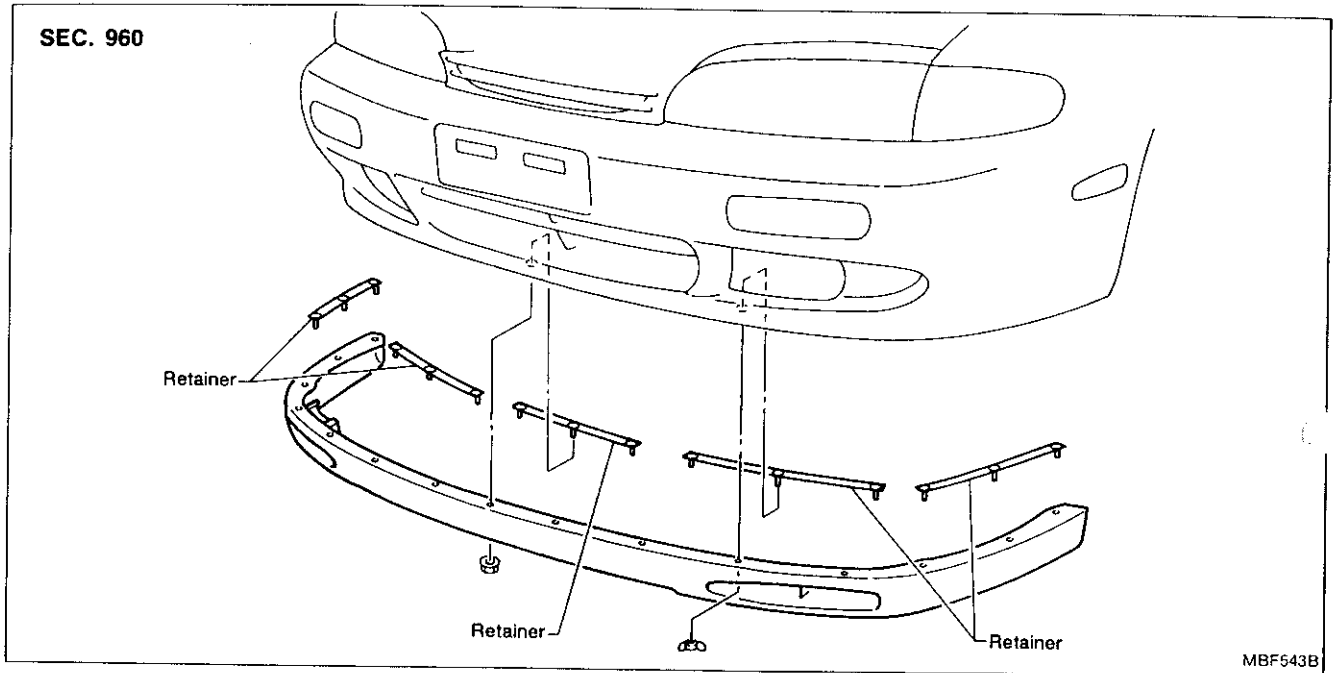

### Rear Air Spoiler

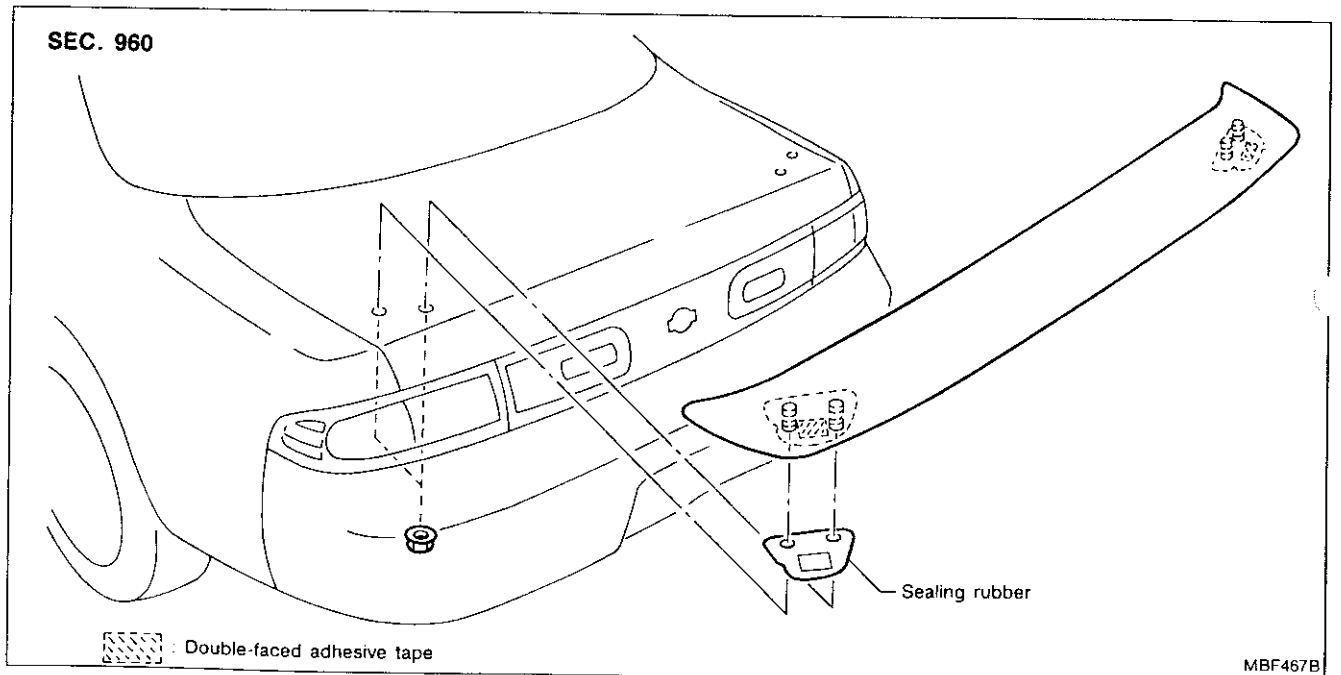

# BODY ALIGNMENT

## Underbody

### MEASUREMENT

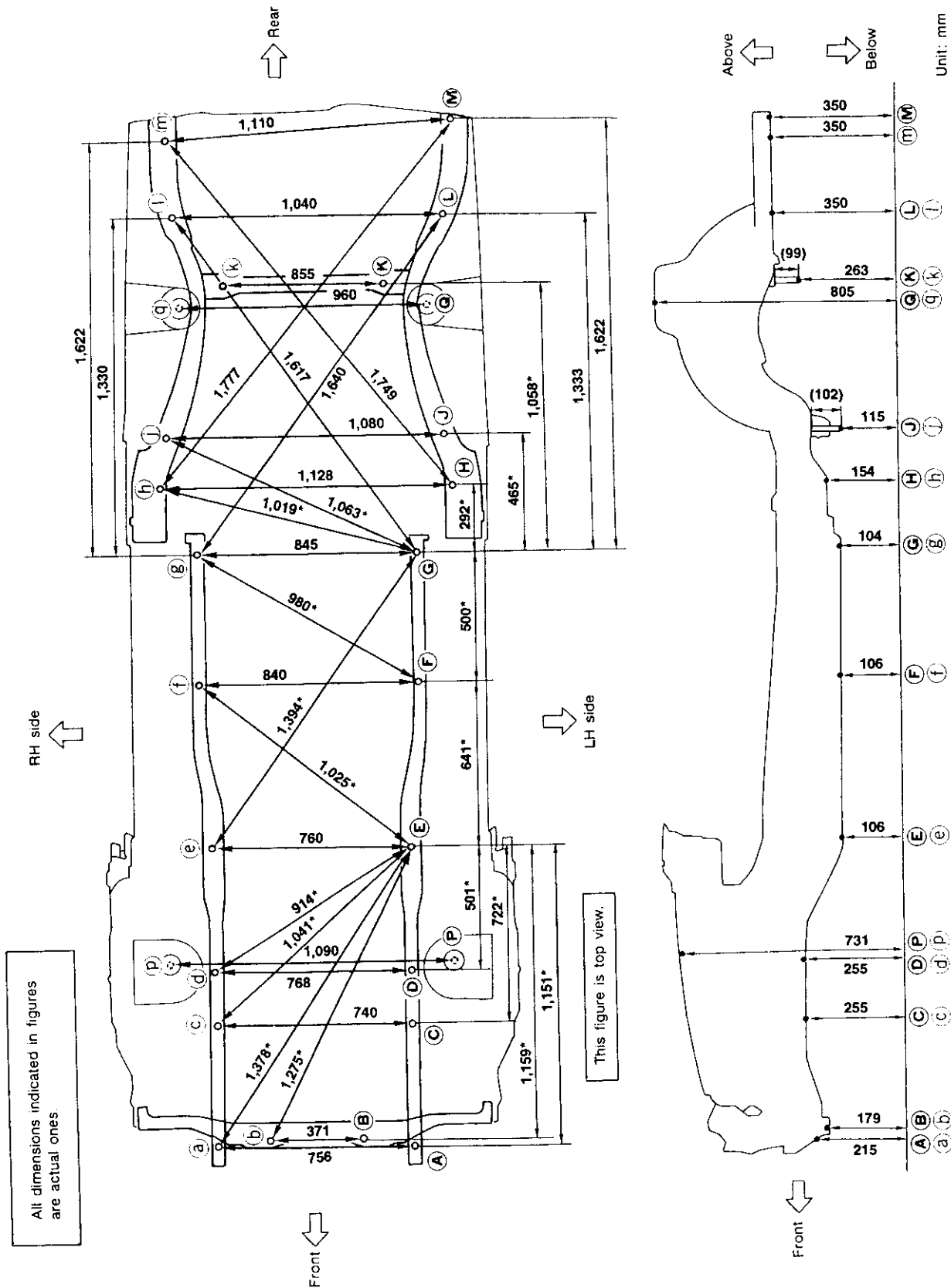

- BT
- HA
- EL
- DX
- RS
- ST
- SP
- BA
- FA
- PD
- AT
- MT
- CL
- FE
- ES
- LC
- EM
- WA
- GT

# BODY ALIGNMENT

## Engine Compartment (Cont'd)

### MEASUREMENT POINTS

Unit: mm

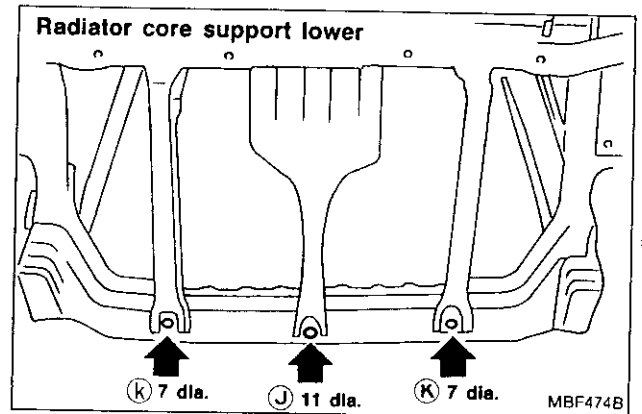
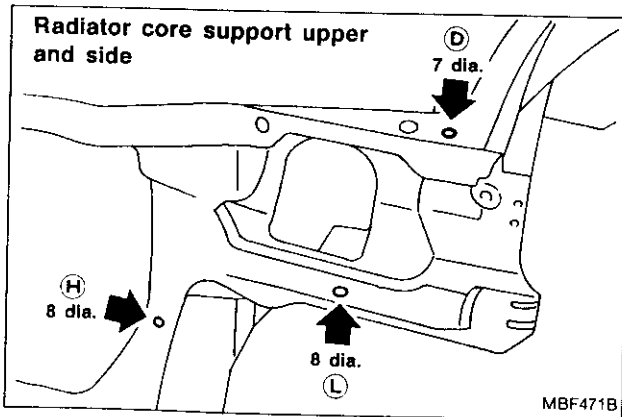
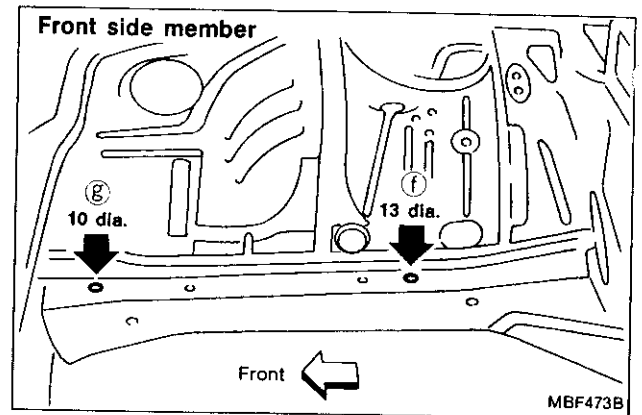
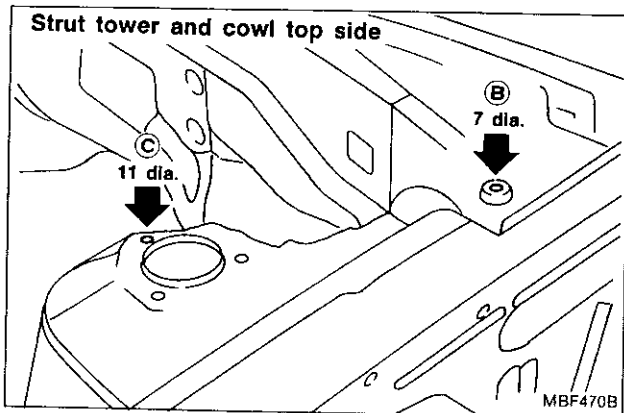
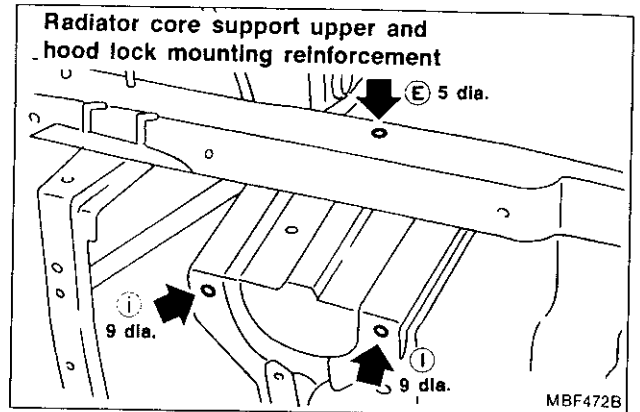
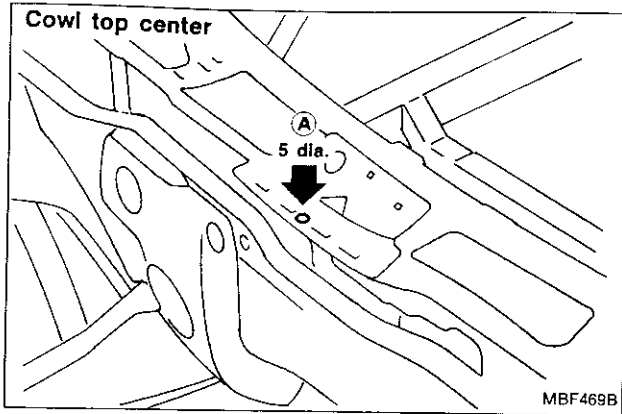

# BODY ALIGNMENT

## Underbody (Cont'd)

### MEASUREMENT POINTS

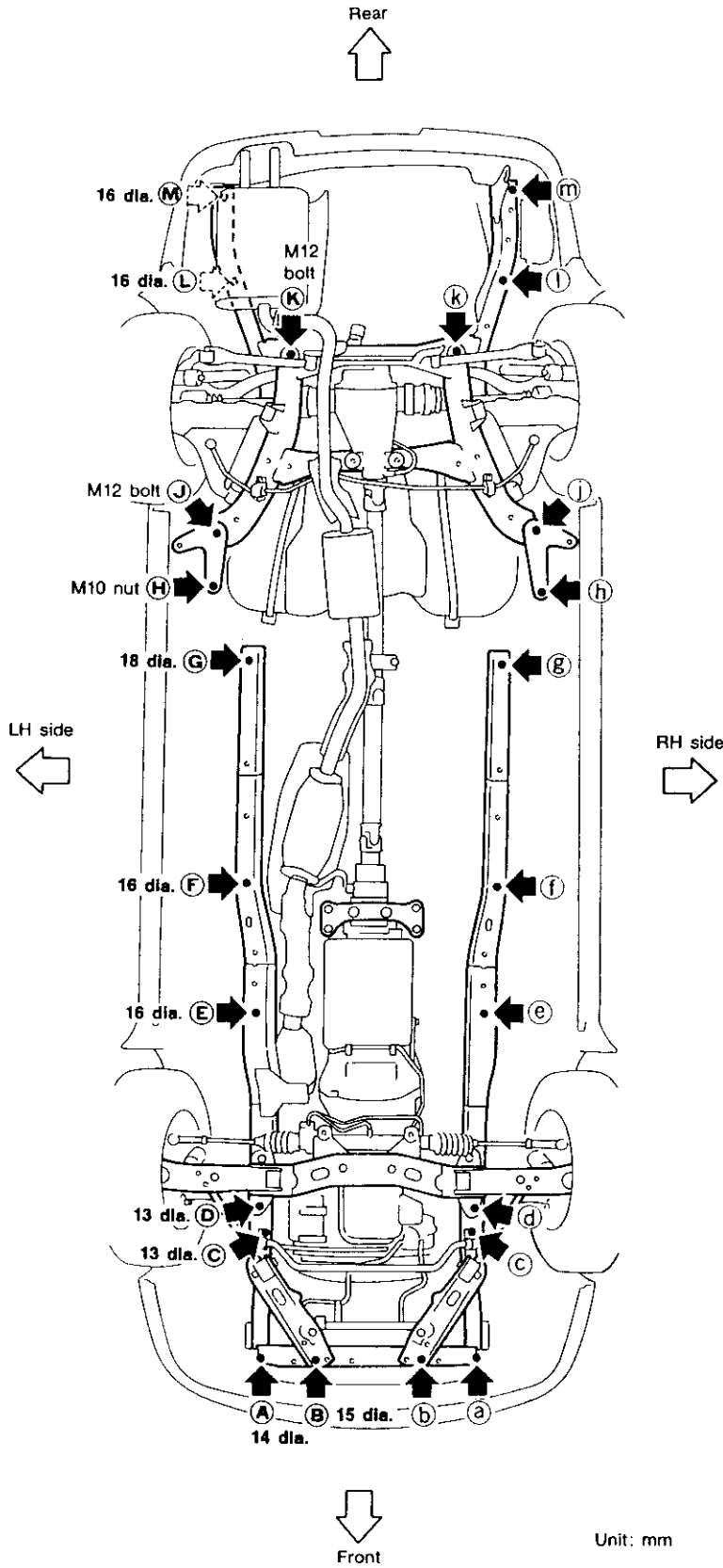

Front coordinates:

**(A, a)**  
X : 378  
Y : -635.5  
Z : 214.5

**(B, b)**  
X : 185.3  
Y : -630  
Z : 179

**(C, c)**  
X : 370  
Y : -196.5  
Z : 254.9

**(D, d)**  
X : 384.2  
Y : 32  
Z : 254.9

**(E, e)**  
X : 380  
Y : 510  
Z : 106.2

**(F, f)**  
X : 420  
Y : 1,150  
Z : 106.2

Rear coordinates:

**(G, g)**  
X : 422.5  
Y : 1,650  
Z : 103.9

**(H, h)**  
X : 564  
Y : 1,900  
Z : 154

**(J, j)**  
X : 540  
Y : 2,100  
Z : 115.2

**(K, k)**  
X : 308  
Y : 2,690  
Z : 262.8

**(L)**  
X : 540  
Y : 2,955  
Z : 350

**(I)**  
X : 500  
Y : 2,955  
Z : 350

**(M)**  
X : 580  
Y : 3,245  
Z : 350

**(n)**  
X : 530  
Y : 3,250  
Z : 350

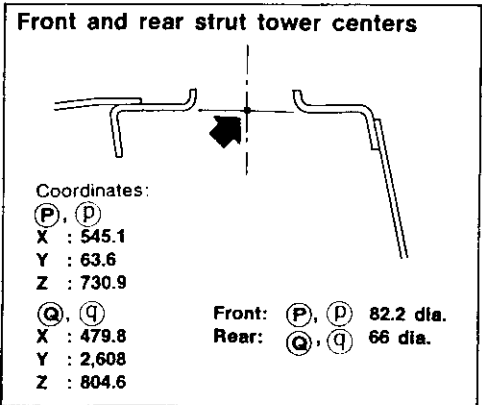

Unit: mm

MBF477BA

# HEATER & AIR CONDITIONER

## SECTION HA

### CONTENTS

<input type="checkbox"/>	<b>MANUAL AND AUTO</b>	<input type="checkbox"/>
<b>PRECAUTIONS AND PREPARATION</b>		3
Supplemental Restraint System (SRS) "AIR BAG" and "SEAT BELT PRE-TENSIONER"		3
Precautions for Working with HFC-134a (R-134a)		3
General Refrigerant Precautions		3
Precautions for Refrigerant Connection		4
Precautions for Servicing Compressor		5
Special Service Tools		5
HFC-134a (R-134a) Service Tools and Equipment		6
Precautions for Service Equipment		8
<b>DESCRIPTION</b>		10
Refrigeration Cycle		10
Component Layout		11
Discharge Air Flow		12
<input type="checkbox"/>	<b>MANUAL</b>	<input type="checkbox"/>
<b>DESCRIPTION</b>		13
Control Operation		13
<b>TROUBLE DIAGNOSES</b>		14
Contents		14
Wiring Diagram — HEAT		37
Wiring Diagram — A/C, M		45
<input type="checkbox"/>	<b>AUTO</b>	<input type="checkbox"/>
<b>DESCRIPTION</b>		72
Introduction		72
Features		72
Control Operation		73

<b>TROUBLE DIAGNOSES</b>		76
Contents		76
Wiring Diagram — A/C, A		104
<b>SYSTEM DESCRIPTION</b>		127
Overview of Control System		127
Control System Input Components		128
Control System Automatic Amplifier (Auto amp.)		130
Control System Output Components		130
<input type="checkbox"/>	<b>MANUAL AND AUTO</b>	<input type="checkbox"/>
<b>SERVICE PROCEDURES</b>		138
HFC-134a (R-134a) Service Procedure		138
Maintenance of Lubricant Quantity in Compressor		140
Refrigerant Lines		142
Compressor Mounting		144
Belt Tension		144
Fast Idle Control Device (FICD)		144
Compressor — Model DKV-14C (ZEXEL make)		145

<input type="checkbox"/>	<b>MANUAL</b>	<input type="checkbox"/>
<b>SERVICE PROCEDURES</b>		148
Overhaul — Push Control Unit Assembly		148
Disassembly		148

<input type="checkbox"/>	<b>MANUAL AND AUTO</b>	<input type="checkbox"/>
<b>SERVICE DATA AND SPECIFICATIONS (SDS)</b>		149
General Specifications		149
Inspection and Adjustment		149

GI  
MA  
EM  
LC  
EC  
EE  
CL  
MT  
AT  
PD  
EA  
RA  
BR  
ST  
RS  
RT  
HA  
EL  
DX

## CONTENTS (Cont'd.)

When you read wiring diagrams:

- Read GI section, "HOW TO READ WIRING DIAGRAMS".

- See EL section, "POWER SUPPLY ROUTING" for power distribution circuit.

When you perform trouble diagnoses, read GI section, "HOW TO FOLLOW FLOW CHART IN TROUBLE DIAGNOSES" and "HOW TO PERFORM EFFICIENT DIAGNOSIS FOR AN ELECTRICAL INCIDENT".

### Supplemental Restraint System (SRS) "AIR BAG" and "SEAT BELT PRE-TENSIONER"

The Supplemental Restraint System "Air Bag" and "Seat Belt Pre-tensioner", used along with a seat belt, help to reduce the risk or severity of injury to the driver and front passenger in a frontal collision. The Supplemental Restraint System consists of air bag modules (located in the center of the steering wheel and on the instrument panel on the passenger side), seat belt pre-tensioner, a diagnosis sensor unit, warning lamp, wiring harness and spiral cable. Information necessary to service the system safely is included in the RS section of this Service Manual.

#### WARNING:

- To avoid rendering the SRS inoperative, which could increase the risk of personal injury or death in the event of a collision which would result in air bag inflation, all maintenance must be performed by an authorized NISSAN dealer.
- Improper maintenance, including incorrect removal and installation of the SRS, can lead to personal injury caused by unintentional activation of the system.
- All SRS air bag electrical wiring harnesses and connectors are covered with yellow outer insulation. Do not use electrical test equipment on any circuit related to the SRS.

### Precautions for Working with HFC-134a (R-134a)

#### WARNING:

- CFC-12 (R-12) refrigerant and HFC-134a (R-134a) refrigerant are not compatible. These refrigerants must never be mixed, even in the smallest amounts. If the refrigerants are mixed, compressor failure is likely to occur.
- Use only specified lubricant for the HFC-134a (R-134a) A/C system and HFC-134a (R-134a) components. If lubricant other than that specified is used, compressor failure is likely to occur.
- The specified HFC-134a (R-134a) lubricant rapidly absorbs moisture from the atmosphere. The following handling precautions must be observed:
  - a: When removing refrigerant components from a vehicle, immediately cap (seal) the component to minimize the entry of moisture from the atmosphere.
  - b: When installing refrigerant components to a vehicle, do not remove the caps (unseal) until just before connecting the components. Connect all refrigerant loop components as quickly as possible to minimize the entry of moisture into system.
  - c: Only use the specified lubricant from a sealed container. Immediately reseal containers of lubricant. Without proper sealing, lubricant will become moisture saturated and should not be used.
  - d: Avoid breathing A/C refrigerant and lubricant vapor or mist. Exposure may irritate eyes, nose and throat. Use only approved recovery/recycling equipment to discharge HFC-134a (R-134a) refrigerant. If accidental system discharge occurs, ventilate work area before resuming service. Additional health and safety information may be obtained from refrigerant and lubricant manufacturers.
  - e: Do not allow lubricant (Nissan A/C System Oil Type S) to come in contact with styrofoam parts. Damage may result.

### General Refrigerant Precautions

#### WARNING:

- Do not release refrigerant into the air. Use approved recovery/recycling equipment to capture the refrigerant every time an air conditioning system is discharged.
- Always wear eye and hand protection (goggles and gloves) when working with any refrigerant or air conditioning system.
- Do not store or heat refrigerant containers above 52°C (125°F).
- Do not heat a refrigerant container with an open flame; if container warming is required, place the bottom of the container in a warm pail of water.
- Do not intentionally drop, puncture, or incinerate refrigerant containers.
- Keep refrigerant away from open flames: poisonous gas will be produced if refrigerant burns.
- Refrigerant will displace oxygen, therefore be certain to work in well ventilated areas to prevent suffocation.
- Do not introduce compressed air to any refrigerant container or refrigerant component.



**Service Tools and**

(R-12) refrigerant and/or its  
 or each type of refrigerant/  
 nt fittings (equipment which  
 and HFC-134a (R-134a). This  
 rigerant/lubricant contamina-

color: Light blue  
 marking: HFC-134a (R-134a)  
 e: Thread size  
 ntainer 1/2"-16 ACME



alkylene glycol oil (PAG), type R  
 n: HFC-134a (R-134a) vane rotary  
 rs (Nissan only)  
 40 ml (1.4 imp fl oz)

**Refrigerant Recovery and Recy-  
 Recharging**

ply:  
 (Cigarette lighter)

n.  
 e face indicates R-134a.  
 Thread size  
 CME

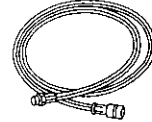
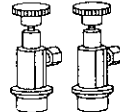
**HFC-134a (R-134a) Service Tools and  
 Equipment (Cont'd)**

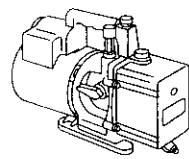
Tool name	Description	Note
Service hoses <ul style="list-style-type: none"> <li>High side hose</li> <li>Low side hose</li> <li>Utility hose</li> </ul>	 NT201	Hose color: <ul style="list-style-type: none"> <li>Low hose: Blue with black stripe</li> <li>High hose: Red with black stripe</li> <li>Utility hose: Yellow with black stripe or green with black stripe</li> </ul> Hose fitting to gauge: <ul style="list-style-type: none"> <li>1/2"-16 ACME</li> </ul>
Service couplers <ul style="list-style-type: none"> <li>High side coupler</li> <li>Low side coupler</li> </ul>	 NT202	Hose fitting to service hose: <ul style="list-style-type: none"> <li>M14 x 1.5 fitting is optional or permanently attached.</li> </ul>
Refrigerant weight scale	 NT200	For measuring of refrigerant Fitting size: Thread size <ul style="list-style-type: none"> <li>1/2"-16 ACME</li> </ul>
Vacuum pump (Including the isolator valve)	 NT203	Capacity: <ul style="list-style-type: none"> <li>Air displacement: 4 CFM</li> <li>Micron rating: 20 microns</li> <li>Oil capacity: 482 g (17 oz)</li> </ul> Fitting size: Thread size <ul style="list-style-type: none"> <li>1/2"-16 ACME</li> </ul>



Service Equipment (Cont'd)

WRS

Connect HFC-134a (R-134a) service couplers to the A/C system. The HFC-134a (R-134a) couplers connect to the CFC-12 (R-12) system. If a proper connection is attempted, discharging may occur.

	A/C service valve
	Open
	Close

EIGHT SCALE

Refrigerant other than HFC-134a (R-134a) and have been used with the scale. If the scale flow electronically, the hose fitting must be

WIDER

Cylinder is not recommended. Refrigerant should be drawn from cylinder's top valve when filling with refrigerant. Also, the accuracy of the cylinder is not as good as that of an electronic scale or of quality equipment.

GI  
MA  
EM  
LG  
EC  
FE  
GL  
WT  
AT  
PC  
EA  
NA  
NR  
ST  
ES  
RI  
HA  
EL  
DN

Refrigeration Cycle

rd pattern. Refrigerant flows through the compressor, condenser, the compressor. the evaporator coil is controlled by an externally equalized expansion valve.

maintain the evaporator temperature within a specified range. When below a specified point, the thermo control amplifier interrupts the evaporator coil temperature rises above the specification, the thermo operation.

ION

on the liquid tank. If the system pressure rises or falls out of normal range, the triple-pressure switch closes the compressor clutch operation. Triple-pressure switch closes system pressure.

°F), thereby discharging refrigerant to the atmosphere. If this plug is removed, the refrigerant line and replace liquid tank.

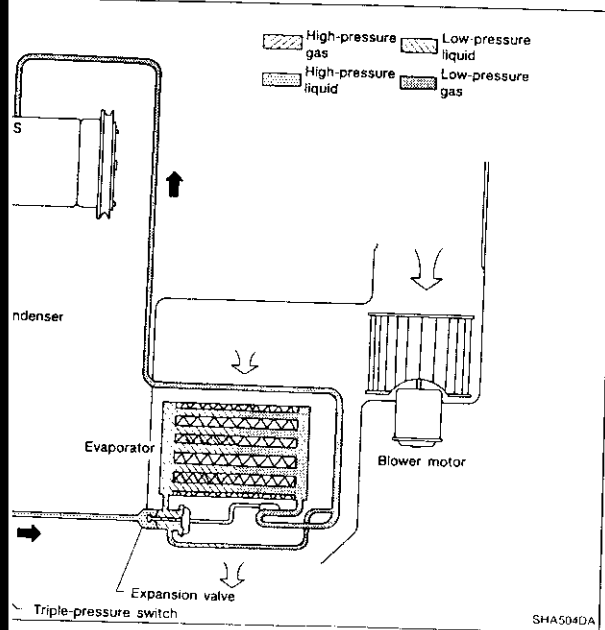

Component Layout

SEC. 270-271-272-273-685

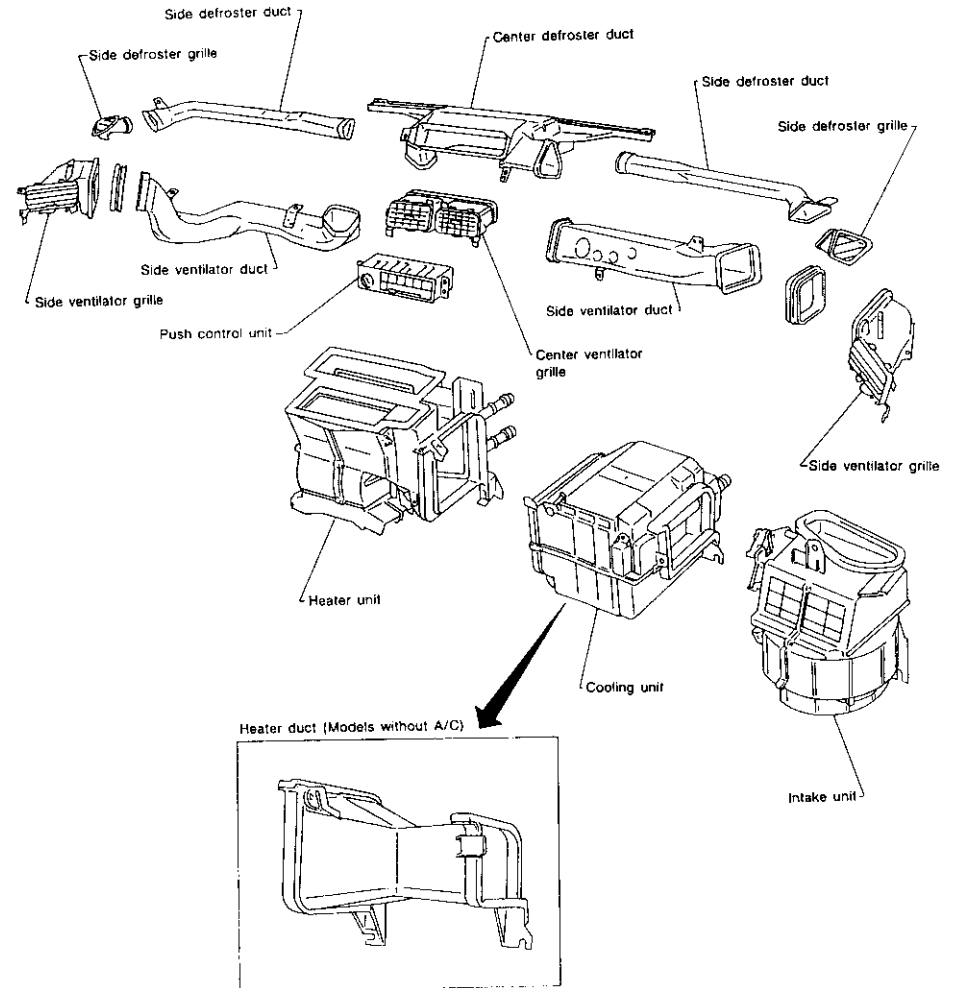

## Control Operation

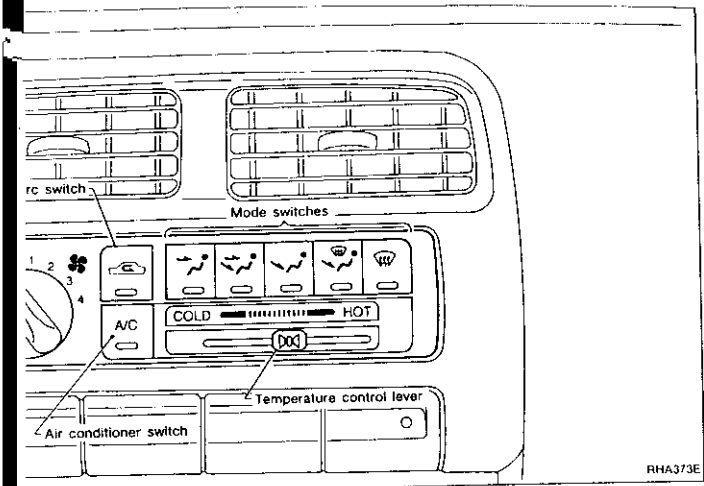

and OFF, and controls fan speed.

outlet air flow.  
 The outside air intake door is set to "FRESH". The compressor turns on in the "DEF" mode.

**LEVER**

controls the temperature of the outlet air.

controls the passenger compartment.

controls the vehicle.

If F or F/D is selected, RECIRC resumes when another mode is chosen.

controls the A/C system. When the switch is depressed with the fan ON, the indicator lamp will also light.

The defrost function operates only when the engine is running.

Contents

Form Trouble Diagnoses for Quick and Accurate Repair ..... HA-15

Check ..... HA-16

Part ..... HA-18

Check ..... HA-18

VARIABLE CHECK 1 ..... HA-20

(Intake door is not set at "FRESH" in DEF or F/D mode.)

VARIABLE CHECK 2 ..... HA-20

(Blower does not blow cold air.)

VARIABLE CHECK 3 ..... HA-21

(Clutch does not engage in DEF mode.)

VARIABLE CHECK 4 ..... HA-22

(Fan speed does not change.)

VARIABLE CHECK 5 ..... HA-23

.....

VARIABLE CHECK 6 ..... HA-24

(Blower does not heat.)

Test Diagnoses ..... HA-25

VENT COOLING ..... HA-26

Chart ..... HA-26

CONDITION ..... HA-28

DRAINING ..... HA-28

Procedures for Abnormal Pressure ..... HA-29

Unit ..... HA-29

Unit — Heater ..... HA-33

Unit — HEAT ..... HA-36

Unit — Manual Air Conditioner ..... HA-37

Unit — Push Control Unit ..... HA-43

Unit — A/C, M ..... HA-44

Apply and Ground Circuit Check ..... HA-45

Procedure 1 ..... HA-55

(Blower motor does not rotate.) ..... HA-56

Procedure 2 ..... HA-58

(Air outlet does not change.) ..... HA-58

Procedure 3 ..... HA-60

(Intake door does not change in VENT, B/L or FOOT mode.) ..... HA-60

Procedure 4 ..... HA-61

(Air mix door does not change.) ..... HA-61

Procedure 5 ..... HA-63

(Bi-level (B/L) door does not operate.) ..... HA-63

Procedure 6 ..... HA-64

(Magnet clutch does not engage when A/C switch and fan switch are ON.) ..... HA-64

Components Inspection ..... HA-68

Adjustment ..... HA-70

How to Perform Trouble Diagnoses for Quick and Accurate Repair

WORK FLOW

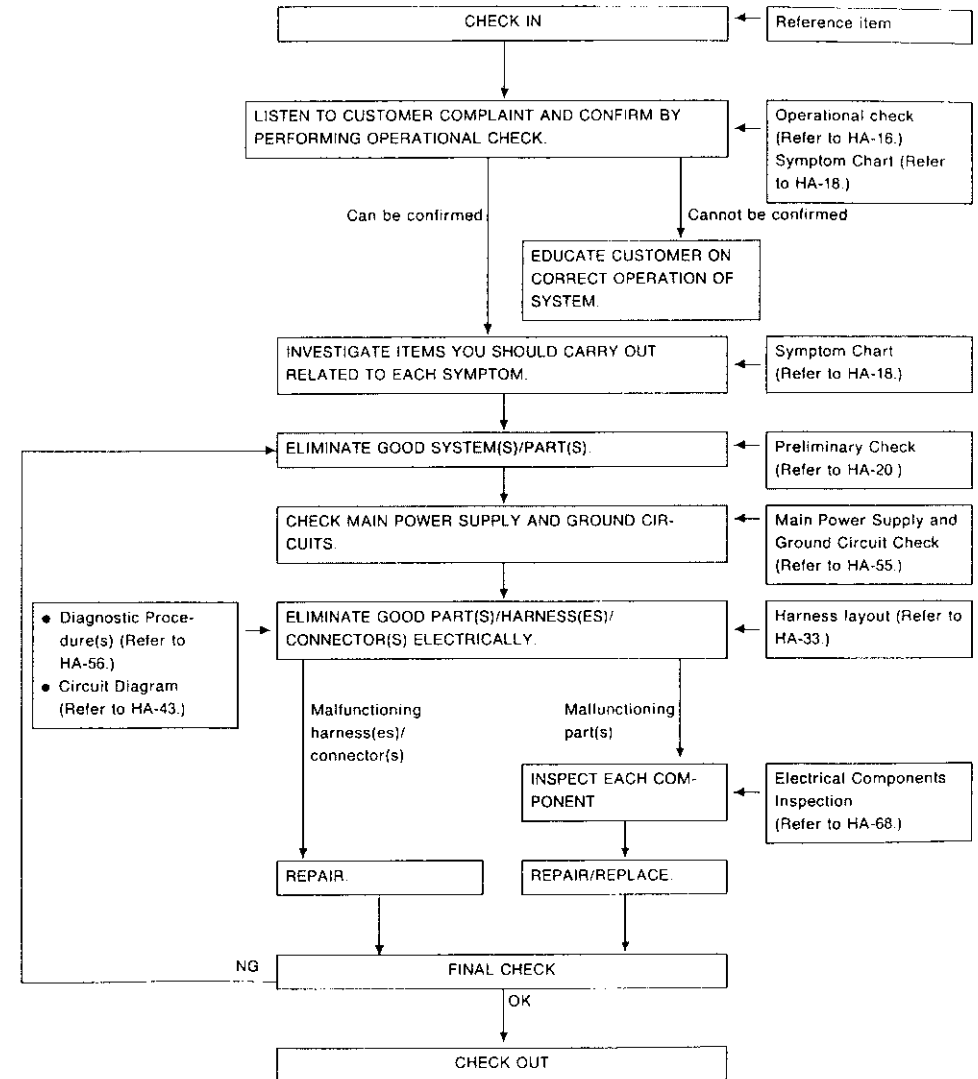

**Operational Check**

The purpose of the operational check is to confirm that the system is as it should be. The systems which will be checked are the blower, mode (discharge air), intake air, temperature decrease, temperature increase and A/C switch.

**CONDITIONS:**

- Engine running and at normal operating temperature.

**PROCEDURE:****1. Check blower**

- 1) Turn fan switch to 1-speed.  
Blower should operate on low speed.
- 2) Then turn fan switch to 2-speed.
- 3) Continue checking blower speed until all speeds are checked.
- 4) Leave blower on speed 4.

**2. Check discharge air.**

- 1) Press each mode switch.

- 2) Confirm that discharge air comes out according to the air distribution table at left.

Refer to "Discharge Air Flow", "DESCRIPTION" (HA-12).

**NOTE:**

Confirm that the compressor clutch is engaged (visual inspection) and intake door position is at FRESH when the DEF button is pressed.

Confirm that the intake door position is at FRESH when the F/D button is pressed.

Intake door position is checked in the next step.

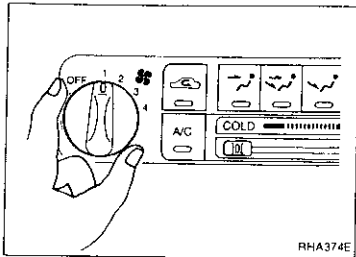

RHA374E

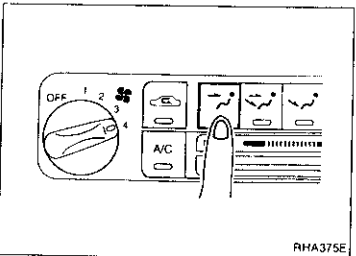

RHA375E

**Discharge air flow**

Switch mode/ indicator	Air outlet/distribution		
	Face	Foot	Defroster
	100%	-	-
	60%	40%	-
	-	80%	20%
	-	60%	40%
	-	-	100%

RHA376A

**Operational Check (Cont'd)****3. Check recirc**

- 1) Press REC switch.  
Recirc indicator should illuminate.
- 2) Listen for intake door position change (you should hear blower sound change slightly).

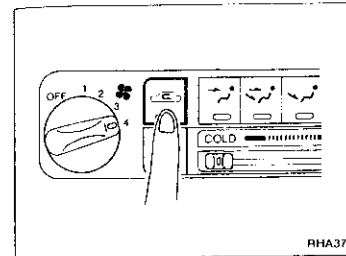

RHA377E

**4. Check temperature decrease**

- 1) Slide temperature control lever to full cold.
- 2) Check for cold air at discharge air outlets.

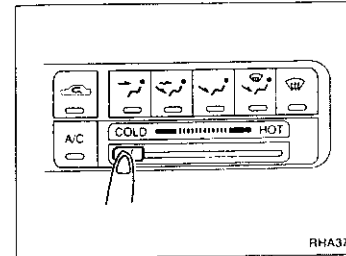

RHA378E

**5. Check temperature increase**

- 1) Slide temperature control lever to full hot.
- 2) Check for hot air at discharge air outlets.

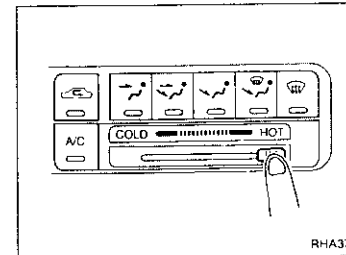

RHA379E

**6. Check air conditioning switch**

Move the fan control switch to the desired (1 to 4 speed) position and push the A/C switch to turn ON the air conditioner.

The indicator lamp should come on when air conditioner is ON.

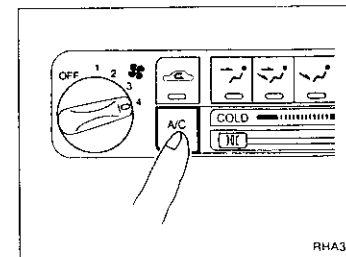

RHA380E

Symptom Chart

DIAGNOSTIC TABLE

PROCEDURE	Preliminary Check						Diagnostic Procedure						Main Power Supply and Ground Circuit Check			
	HA-20	HA-21	HA-22	HA-23	HA-24	HA-25	HA-56	HA-56	HA-60	HA-61	HA-63	HA-64	HA-55	HA-55	HA-55	HA-55
SYMPTOM	Preliminary check 1	Preliminary check 2	Preliminary check 3	Preliminary check 4	Preliminary check 5	Preliminary check 6	Diagnostic procedure 1	Diagnostic procedure 2	Diagnostic procedure 3	Diagnostic procedure 4	Diagnostic procedure 5	Diagnostic procedure 6	15A Fuses (#7, #8)	7.5A Fuse (#6 or #15)	7.5A Fuse (#42)	Push control unit
A/C does not blow cold air.	①						○						○	○		
Insufficient heating.						①	○			○						
Blower motor does not rotate.	①						②					○				
Air outlet does not change.			①					②								○
Intake door does not change in VENT, B/L or FOOT mode.									①							○
Intake door is not set at "FRESH" in DEF or F/D mode.	①								○							○
Air mix door does not change.		①								②						
Bi-level door does not change.											①					
Magnet clutch does not engage when A/C switch and fan switch are ON.		①										②		○	○	
Magnet clutch does not engage in DEF mode.	①	②											○	○	○	
Noise					①											

①, ②: The number means checking order.  
○: Checking order depends on malfunction in each flow chart

Symptom Chart (Cont'd)

PROCEDURE	Electrical Components Inspection															
	HA-68	HA-68														
Blower motor	○	○														
Resistor	○	○														
A/C switch	○															
REC switch			○													
VENT switch				○												
B/L switch					○											
FOOT switch						○										
F/D switch							○									
DEF switch								○								
Fan switch									○							
Mode door motor										○						
Intake door motor											○					
Air mix door motor												○				
BI-LEVEL (B/L) door motor													○			
A/C relay														○		
Triple-pressure switch															○	
Compressor (Magnet clutch)																○
Compressor																○
Thermal protector																○
ECM (ECCS control module)																○
Refer to EC section.																○
Harness																○

## Preliminary Check

## PRELIMINARY CHECK 1

Intake door is not set at "FRESH" in DEF or F/D mode.

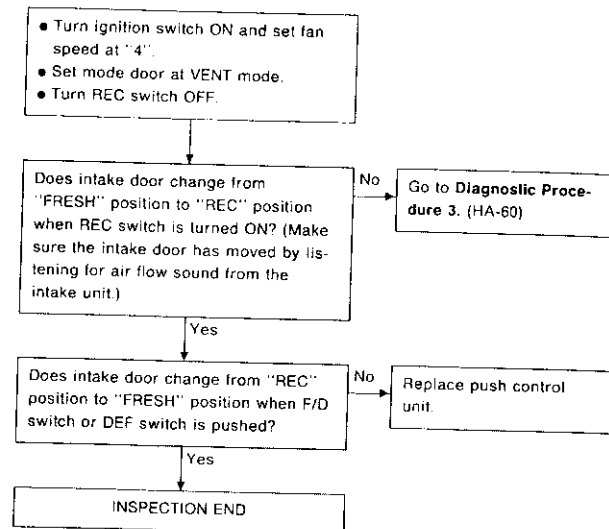

## Preliminary Check (Cont'd)

## PRELIMINARY CHECK 2

A/C does not blow cold air.

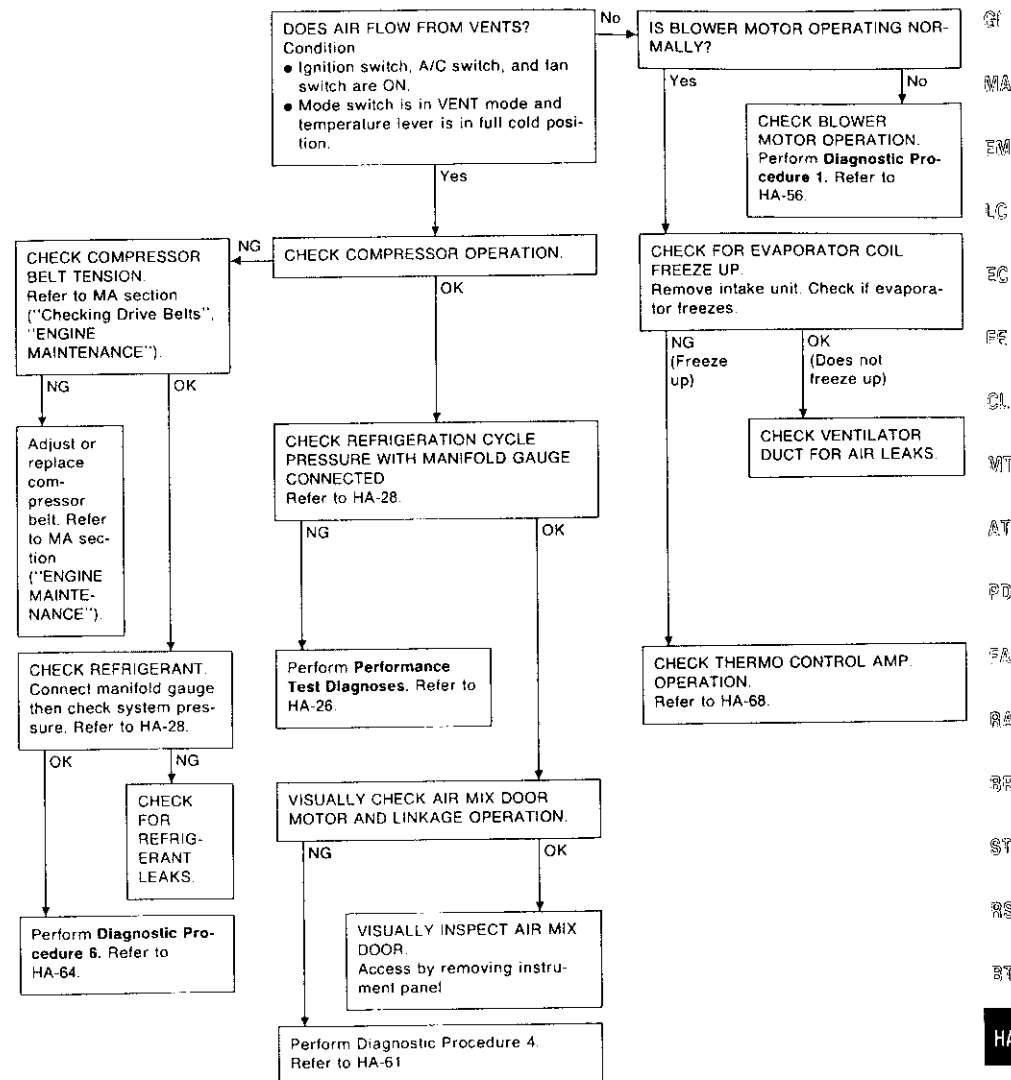

Preliminary Check (Cont'd)

PRELIMINARY CHECK 3

Magnet clutch does not engage in DEF mode.

- Perform PRELIMINARY CHECK 2 before referring to the following flow chart.

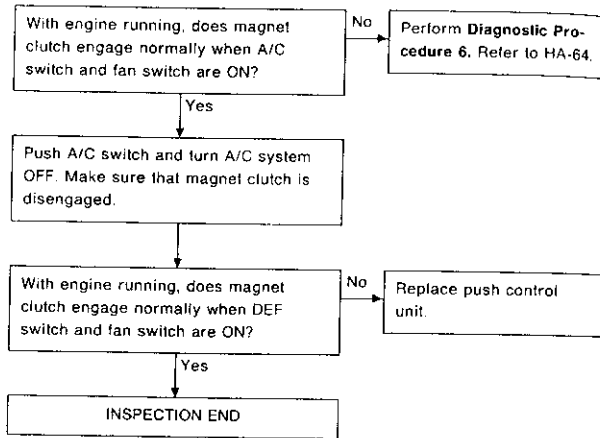

Preliminary Check (Cont'd)

PRELIMINARY CHECK 4

Air outlet does not change.

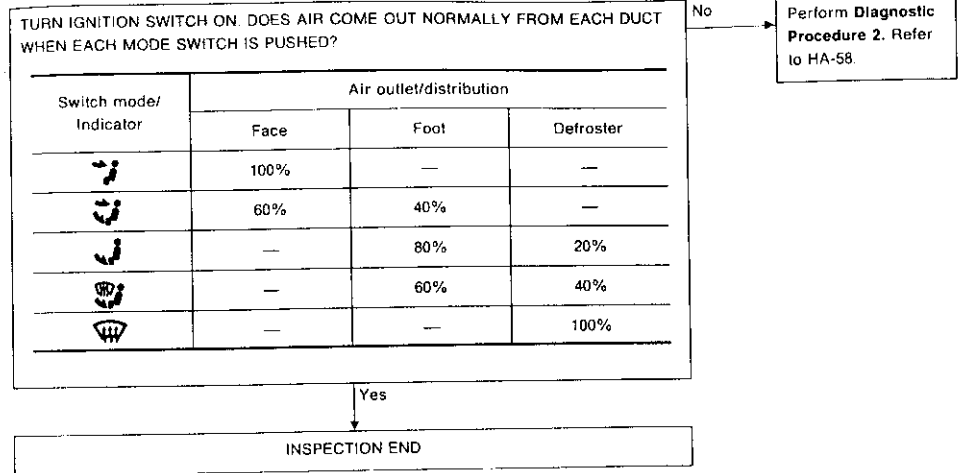

21  
 22  
 23  
 24  
 25  
 26  
 27  
 28  
 29  
 30  
 31  
 32  
 33  
 34  
 35  
 36  
 37  
 38  
 39  
 40  
 41  
 42  
 43  
 44  
 45  
 46  
 47  
 48  
 49  
 50  
 51  
 52  
 53  
 54  
 55  
 56  
 57  
 58  
 59  
 60  
 61  
 62  
 63  
 64  
 65  
 66  
 67  
 68  
 69  
 70  
 71  
 72  
 73  
 74  
 75  
 76  
 77  
 78  
 79  
 80  
 81  
 82  
 83  
 84  
 85  
 86  
 87  
 88  
 89  
 90  
 91  
 92  
 93  
 94  
 95  
 96  
 97  
 98  
 99  
 100

HA



## PRELIMINARY CHECK 5

Noise

## Preliminary Check (Cont'd)

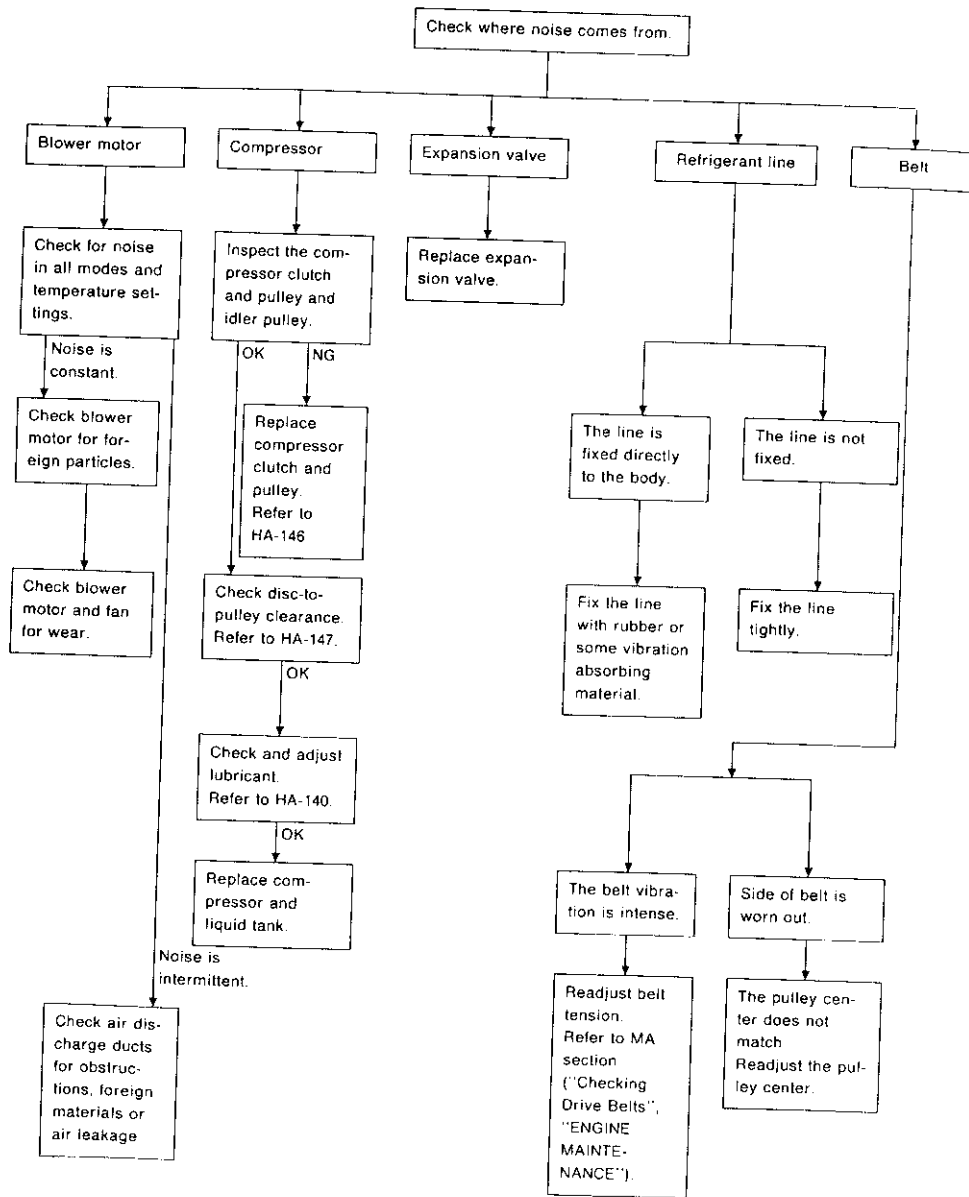

## PRELIMINARY CHECK 6

Insufficient heating

## Preliminary Check (Cont'd)

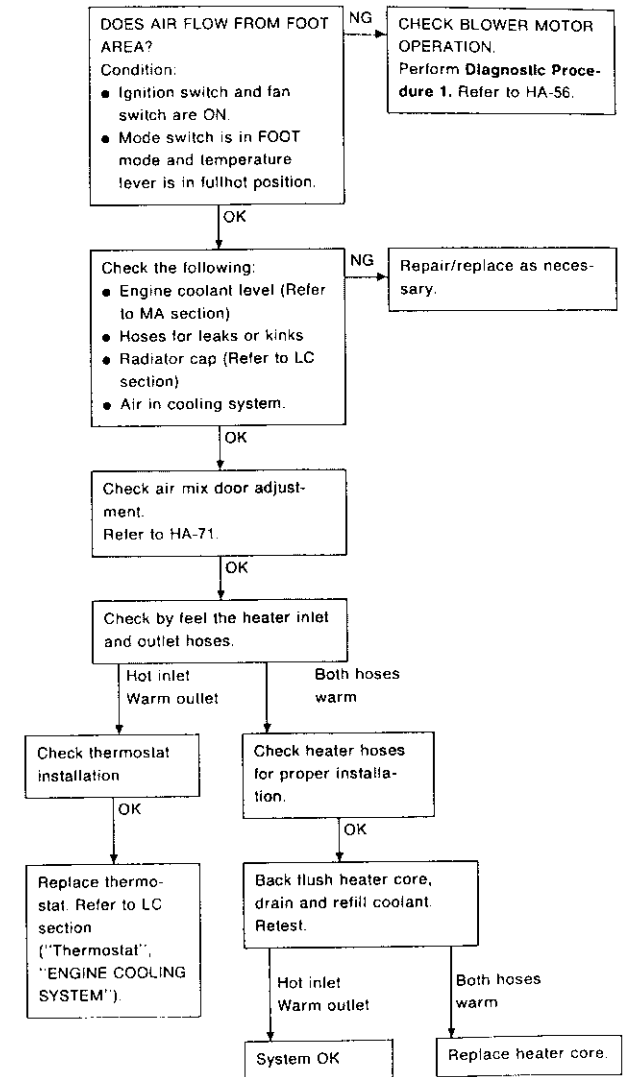

Performance Test Diagnoses  
INSUFFICIENT COOLING

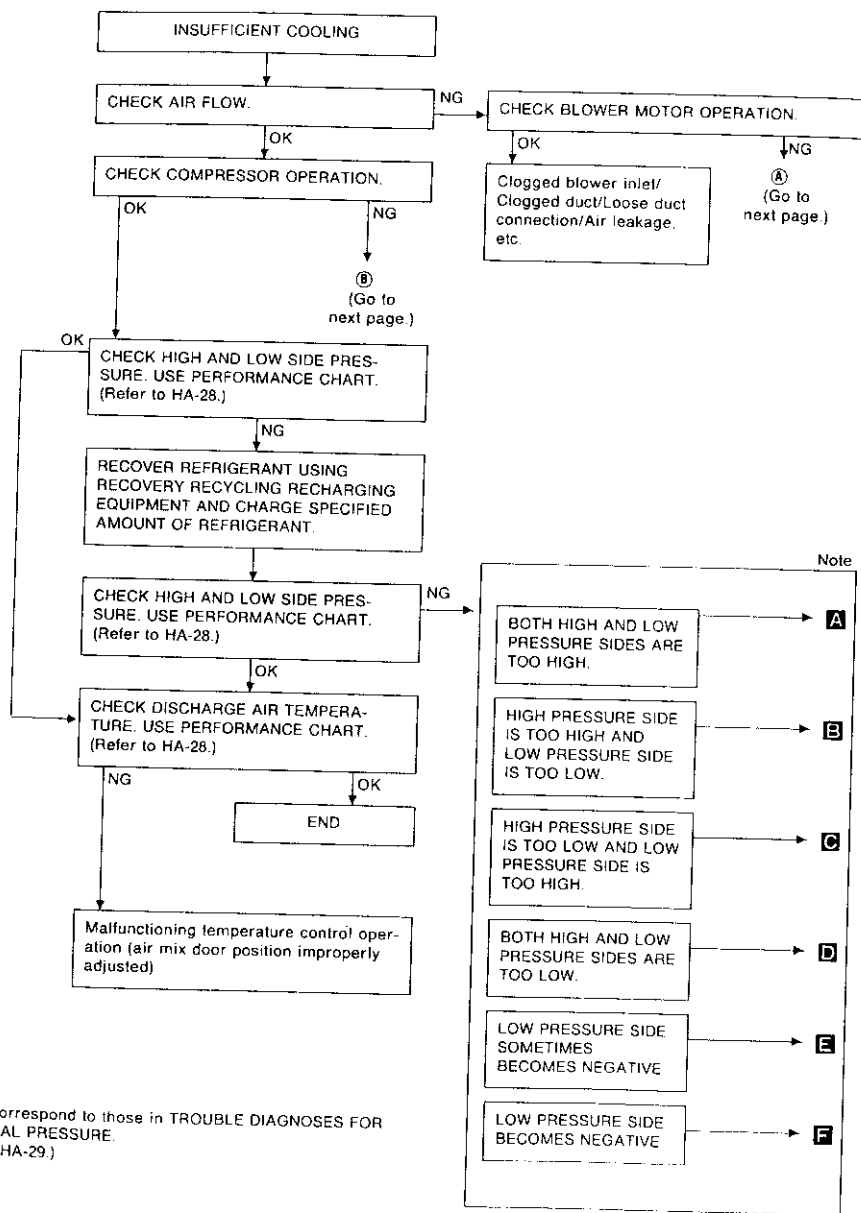

Note: **A-F** correspond to those in TROUBLE DIAGNOSES FOR ABNORMAL PRESSURE. (Refer to HA-29.)

Performance Test Diagnoses (Cont'd)

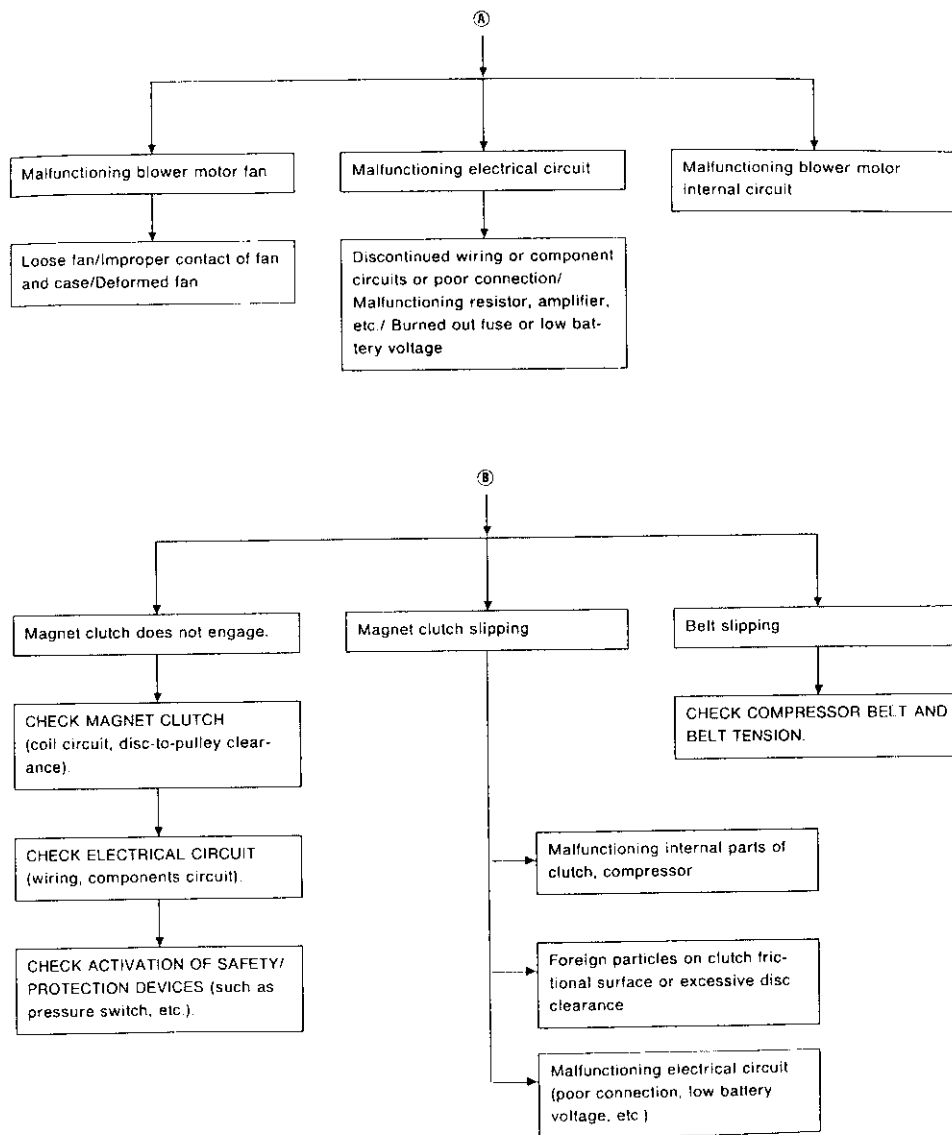

## Performance Chart

## TEST CONDITION

Testing must be performed as follows:

Vehicle location: Indoors or in the shade (in a well ventilated place)

Doors: Closed

Door window: Open (Front driver side only)

Hood: Open

TEMP. setting: Max. COLD

Discharge Air: Face Vent

RECIRC switch: (Recirculation) ON

FAN speed: High speed

A/C switch: ON

Engine speed: Idle speed

Operate the air conditioning system for 10 minutes before taking measurements.

## TEST READING

## Recirculating-to-discharge air temperature table

Inside air at blower assembly inlet for RECIRC*		Discharge air temperature at center ventilator °C (°F)
Relative humidity %	Air temperature °C (°F)	
50 - 60	20 (68)	6.2 - 8.8 (43 - 48)
	25 (77)	10.4 - 13.5 (51 - 56)
	30 (86)	14.6 - 18.2 (58 - 65)
	35 (95)	18.7 - 23.0 (66 - 73)
60 - 70	20 (68)	8.8 - 11.6 (48 - 53)
	25 (77)	13.5 - 16.8 (56 - 62)
	30 (86)	18.2 - 22.0 (65 - 72)
	35 (95)	23.0 - 27.2 (73 - 81)

\* Thermometer should be placed at intake unit under RH side of instrument panel.

## Ambient air temperature-to-operating pressure table

Ambient air		High-pressure (Discharge side) kPa (bar, kg/cm <sup>2</sup> , psi)	Low-pressure (Suction side) kPa (bar, kg/cm <sup>2</sup> , psi)
Relative humidity %	Air temperature °C (°F)		
50 - 70	25 (77)	814 - 991 (8.14 - 9.91, 8.3 - 10.1, 118 - 144)	147 - 216 (1.47 - 2.16, 1.5 - 2.2, 21 - 31)
	30 (86)	941 - 1,177 (9.41 - 11.77, 9.6 - 12.0, 137 - 171)	157 - 245 (1.57 - 2.45, 1.6 - 2.5, 23 - 36)
	35 (95)	1,108 - 1,402 (11.08 - 14.02, 11.3 - 14.3, 161 - 203)	177 - 284 (1.77 - 2.84, 1.8 - 2.9, 26 - 41)
	40 (104)	1,304 - 1,677 (13.04 - 16.77, 13.3 - 17.1, 189 - 243)	216 - 343 (2.16 - 3.43, 2.2 - 3.5, 31 - 50)

If pressure is not within range, refer to HA-29, "Trouble Diagnoses for Abnormal Pressure".

## Trouble Diagnoses for Abnormal Pressure

Whenever system's high and/or low side pressure is abnormal, diagnose using a manifold gauge. The marker above the gauge scale in the following tables indicates the standard (normal) pressure range. Since the standard (normal) pressure, however, differs from vehicle to vehicle, refer to HA-28 ("Ambient air temperature-to-compressor pressure table").

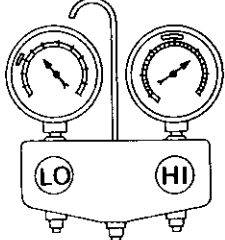
Gauge indication	Refrigerant cycle	Probable cause	Corrective action
 <p>Both high and low-pressure sides are too high.</p>	<ul style="list-style-type: none"> <li>Pressure is reduced soon after water is splashed on condenser</li> </ul>	Excessive refrigerant charge in refrigeration cycle	Reduce refrigerant until specified pressure is obtained.
	<ul style="list-style-type: none"> <li>Air suction by cooling fan is insufficient.</li> </ul>	Insufficient condenser cooling performance ↓ ① Condenser fins are clogged. ② Improper fan rotation of cooling fan	<ul style="list-style-type: none"> <li>Clean condenser.</li> <li>Check and repair cooling fan as necessary.</li> </ul>
	<ul style="list-style-type: none"> <li>Low-pressure pipe is not cold.</li> <li>When compressor is stopped high-pressure value quickly drops by approximately 196 kPa (2.0 bar, 2 kg/cm<sup>2</sup>, 28 psi). It then decreases gradually thereafter.</li> </ul>	Poor heat exchange in condenser (After compressor operation stops, high pressure decreases too slowly.) ↓ Air in refrigeration cycle	Evacuate repeatedly and recharge system.
	<ul style="list-style-type: none"> <li>Engine tends to overheat.</li> </ul>	Engine cooling systems malfunction.	Check and repair each engine cooling system.
	<ul style="list-style-type: none"> <li>An area of the low-pressure pipe is colder than areas near the evaporator outlet.</li> <li>Plates are sometimes covered with frost.</li> </ul>	<ul style="list-style-type: none"> <li>Excessive liquid refrigerant on low-pressure side</li> <li>Excessive refrigerant discharge flow</li> <li>Expansion valve is open a little compared with the specification.</li> </ul> ↓ ① Improper thermal valve installation ② Improper expansion valve adjustment	Replace expansion valve.

Trouble Diagnoses for Abnormal Pressure  
(Cont'd)

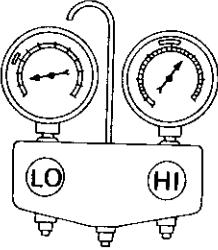
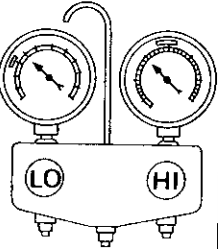
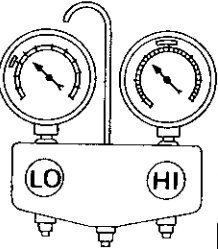
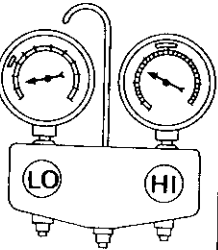
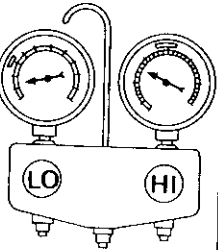
Gauge indication	Refrigerant cycle	Probable cause	Corrective action
High-pressure side is too high and low-pressure side is too low. <b>B</b>  AC360A	Upper side of condenser and high-pressure side are hot, however, liquid tank is not so hot.	High-pressure tube or parts located between compressor and condenser are clogged or crushed.	<ul style="list-style-type: none"> <li>• Check and repair or replace malfunctioning parts.</li> <li>• Check lubricant for contamination.</li> </ul>
High-pressure side is too low and low-pressure side is too high. <b>C</b>  AC356A	High and low-pressure sides become equal soon after compressor operation stops.	Compressor pressure operation is improper. ↓ Damaged inside compressor packings	Replace compressor.
No temperature difference between high and low-pressure sides  AC356A	No temperature difference between high and low-pressure sides	Compressor discharge capacity does not change (Compressor stroke is set at maximum.)	Replace compressor.
Both high- and low-pressure sides are too low. <b>D</b>  AC354A	<ul style="list-style-type: none"> <li>• There is a big temperature difference between liquid tank outlet and inlet. Outlet temperature is extremely low.</li> <li>• Liquid tank inlet and expansion valve are frosted.</li> <li>• Temperature of expansion valve inlet is extremely low as compared with areas near liquid tank.</li> <li>• Expansion valve inlet may be frosted</li> <li>• Temperature difference occurs somewhere in high-pressure side</li> </ul>	Liquid tank inside is clogged a little	<ul style="list-style-type: none"> <li>• Replace liquid tank.</li> <li>• Check lubricant for contamination</li> </ul>
 AC353A		High-pressure pipe located between liquid tank and expansion valve is clogged.	<ul style="list-style-type: none"> <li>• Check and repair malfunctioning parts.</li> <li>• Check lubricant for contamination.</li> </ul>

Trouble Diagnoses for Abnormal Pressure  
(Cont'd)

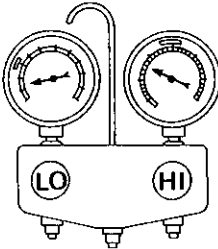
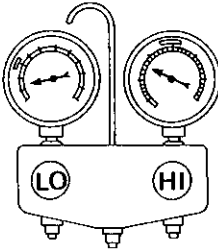
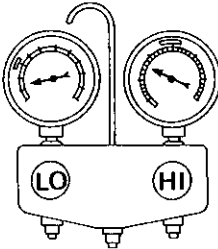
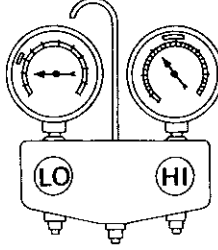
Gauge indication	Refrigerant cycle	Probable cause	Corrective action
Both high- and low-pressure sides are too low. <b>D</b>  AC353A	There is a big temperature difference between expansion valve inlet and outlet while the valve itself is frosted.	Expansion valve closes a little compared with the specification. ↓ ① Improper expansion valve adjustment ② Malfunctioning thermal valve ③ Outlet and inlet may be clogged	<ul style="list-style-type: none"> <li>• Remove foreign particles by using compressed air.</li> <li>• Check lubricant for contamination</li> </ul>
 AC353A	An area of the low-pressure pipe is colder than areas near the evaporator outlet	Low-pressure pipe is clogged or crushed	<ul style="list-style-type: none"> <li>• Check and repair malfunctioning parts.</li> <li>• Check lubricant for contamination.</li> </ul>
Air flow volume is not enough or is too low.  AC353A	Air flow volume is not enough or is too low.	Evaporator is frozen. ↓ Compressor discharge capacity does not change. (Compressor stroke is set at maximum length.)	Replace compressor.
Low-pressure side sometimes becomes negative. <b>E</b>  AC354A	<ul style="list-style-type: none"> <li>• Air conditioning system does not function and does not cyclically cool the compartment air.</li> <li>• The system constantly functions for a certain period of time after compressor is stopped and restarted.</li> </ul>	Refrigerant does not discharge cyclically. ↓ Moisture is frozen at expansion valve outlet and inlet. ↓ Water is mixed with refrigerant	<ul style="list-style-type: none"> <li>• Drain water from refrigerant or replace refrigerant.</li> <li>• Replace liquid tank.</li> </ul>



Layout (Cont'd)

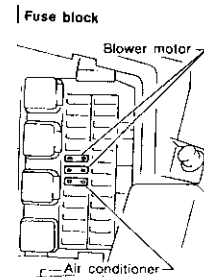
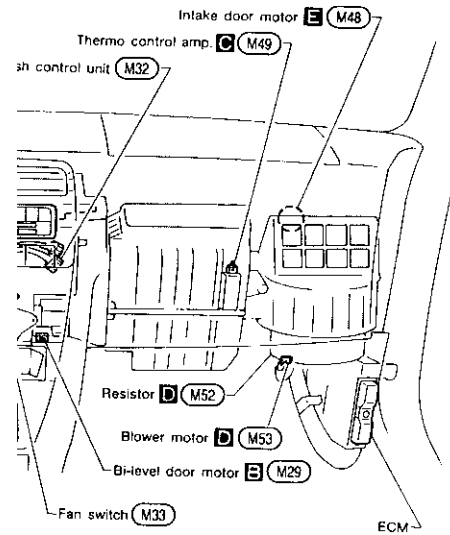
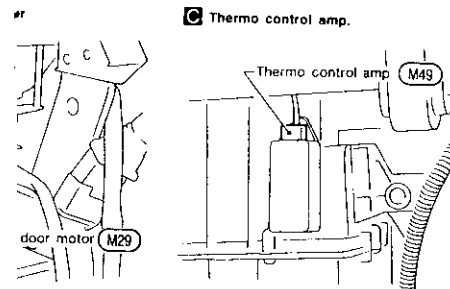

SHA507E

Harness Layout (Cont'd)

RHD model

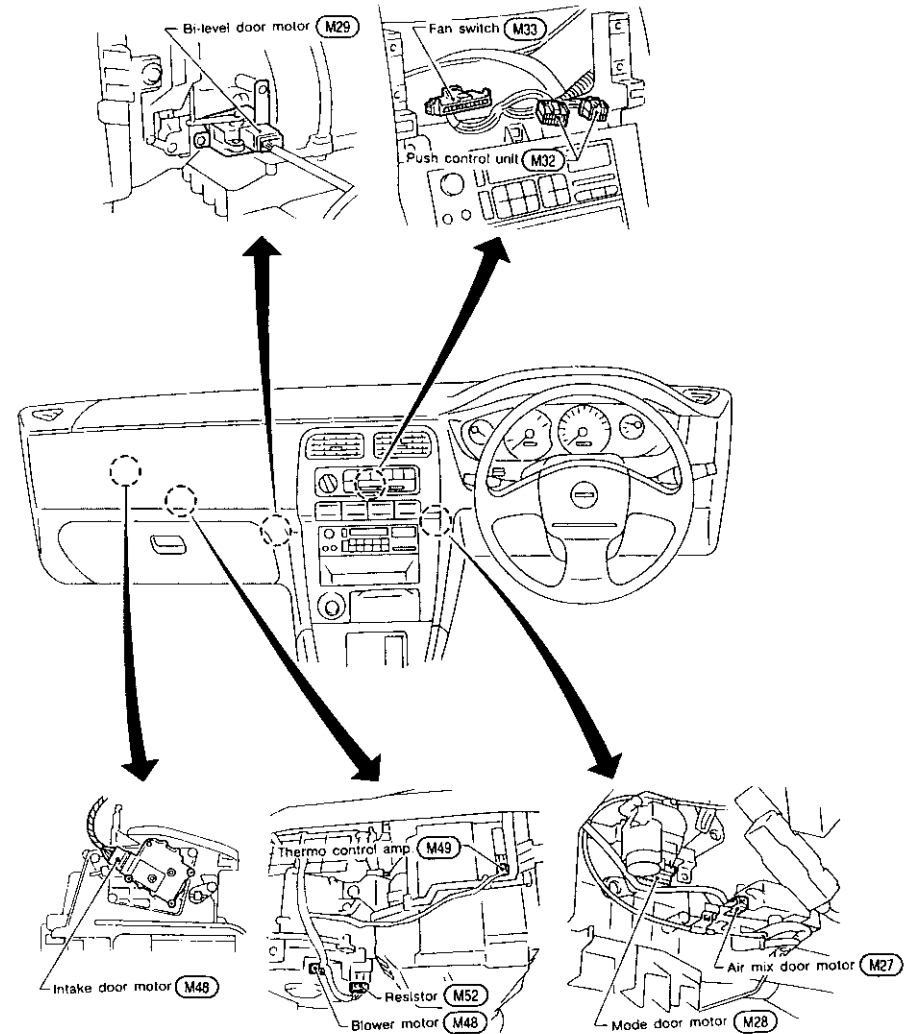

GI  
VA  
EM  
LC  
EC  
EE  
CL  
MT  
AT  
FD  
FA  
RA  
BR  
ST  
RS  
BT  
HA  
EL  
FX

SHA527E

Circuit Diagram — Heater

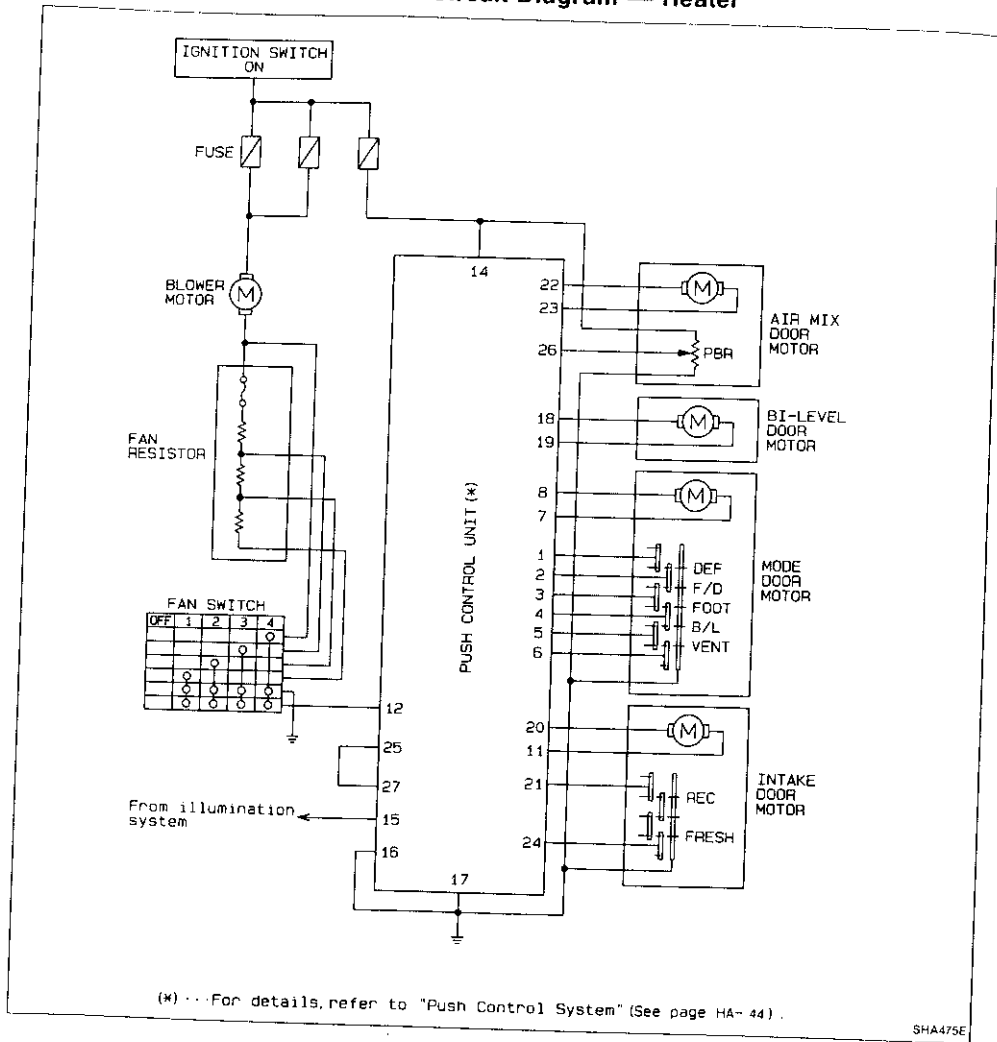

Wiring Diagram — HEAT —

LHD MODEL

HA-HEAT-01

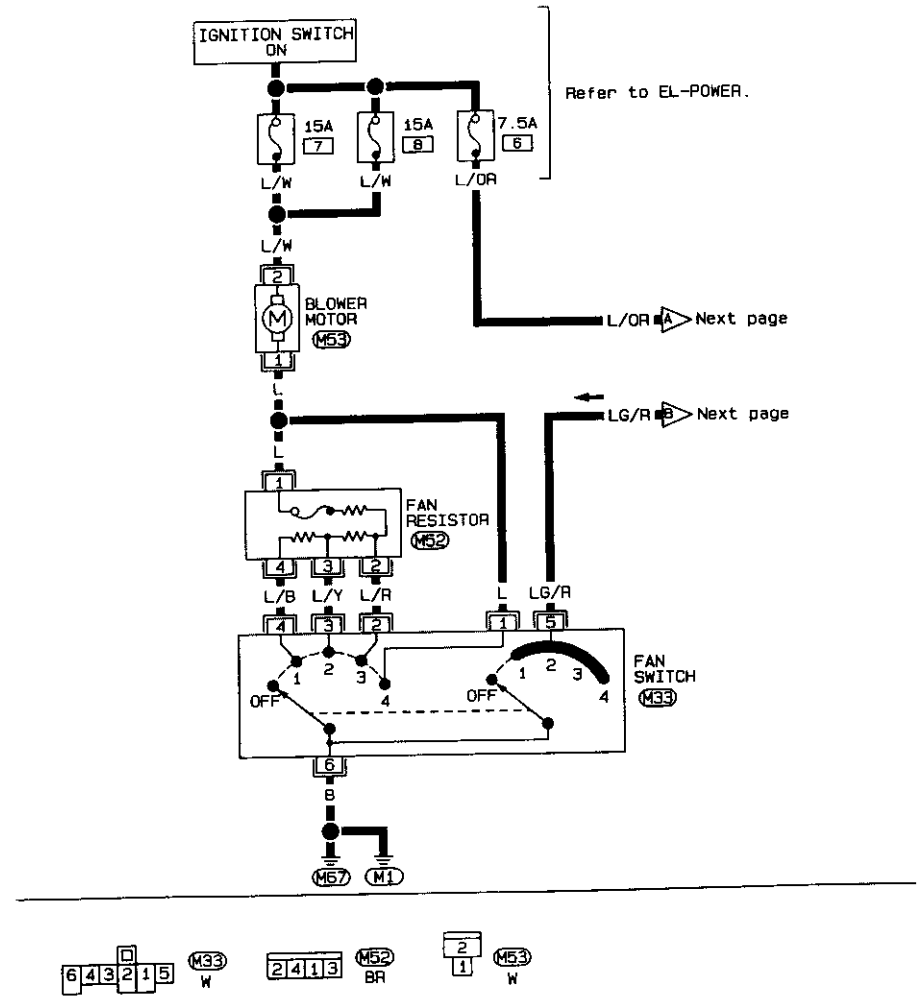

HA-HEAT-02

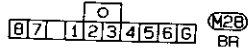
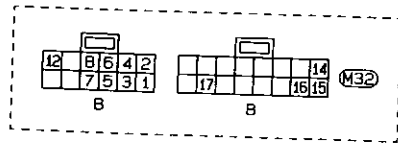
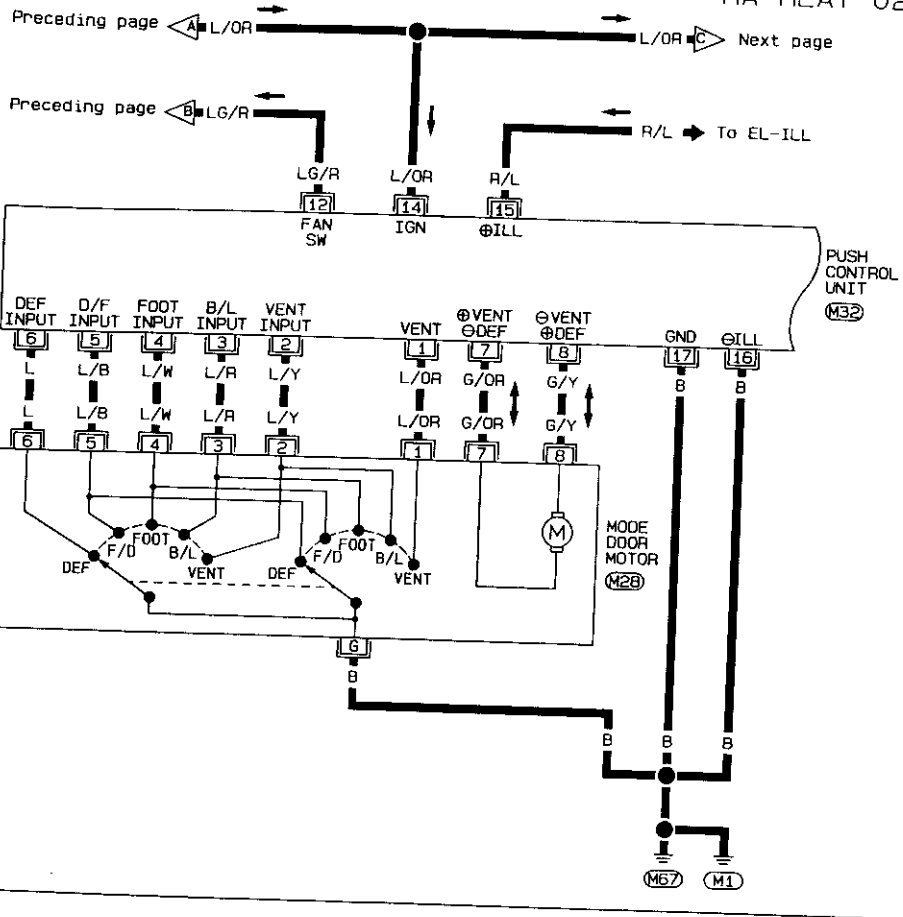

HA-HEAT-03

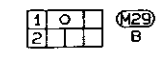
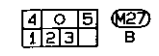
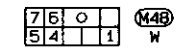
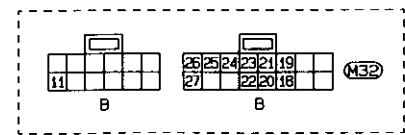
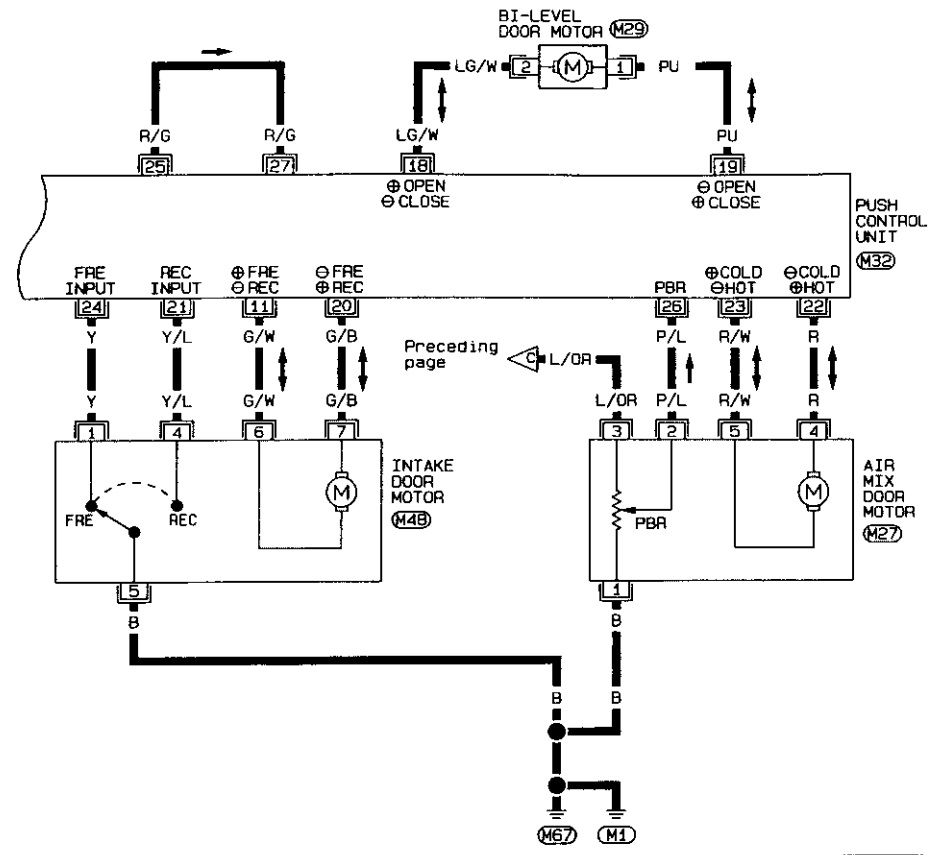



T — (Cont'd)

HA-HEAT-04

EL-POWER.

Next page

Next page

ETCH

Wiring Diagram — HEAT — (Cont'd)

HA-HEAT-05

Preceding page ← L/OR → Next page

Preceding page ← LG/R → R/L → To EL-ILL

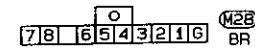
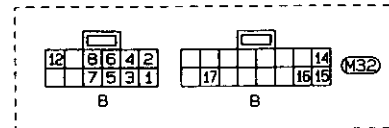
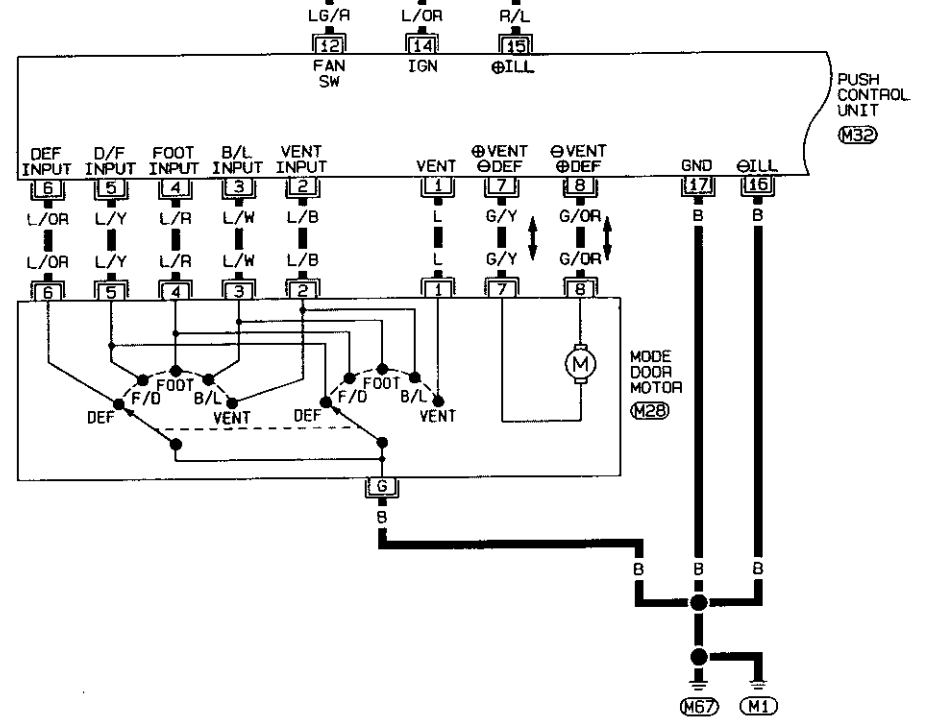

Wiring Diagram — HEAT — (Cont'd)

HA-HEAT-06

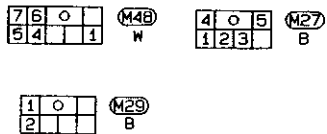
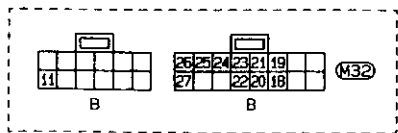
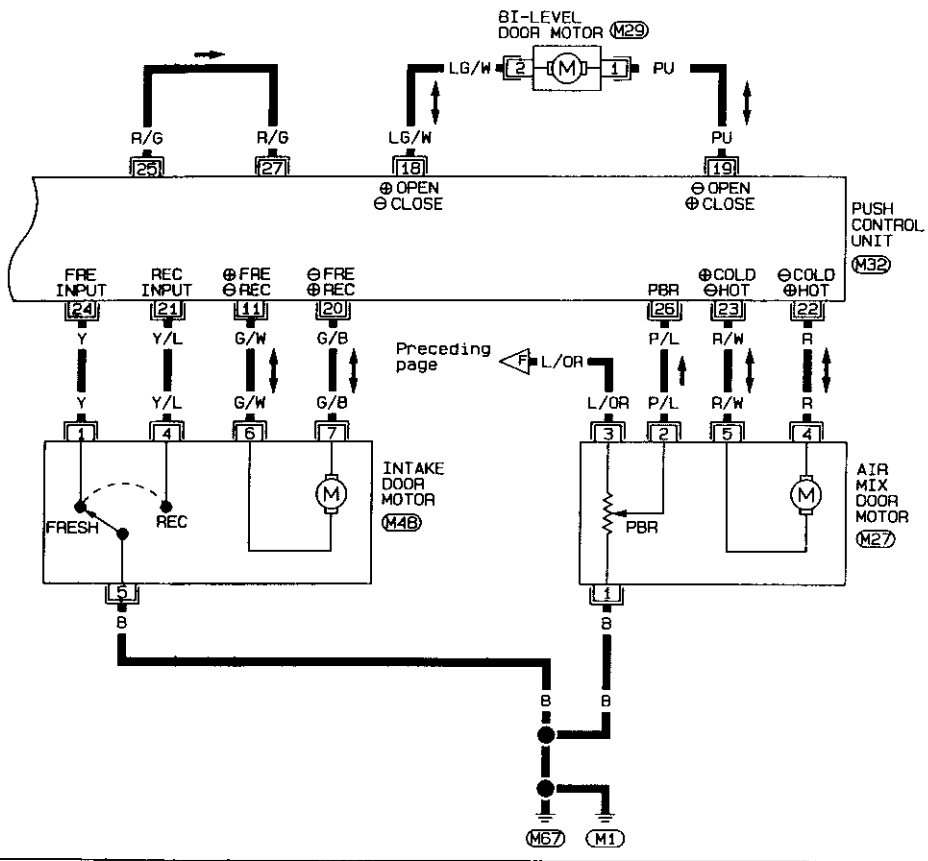

Circuit Diagram — Manual Air Conditioner

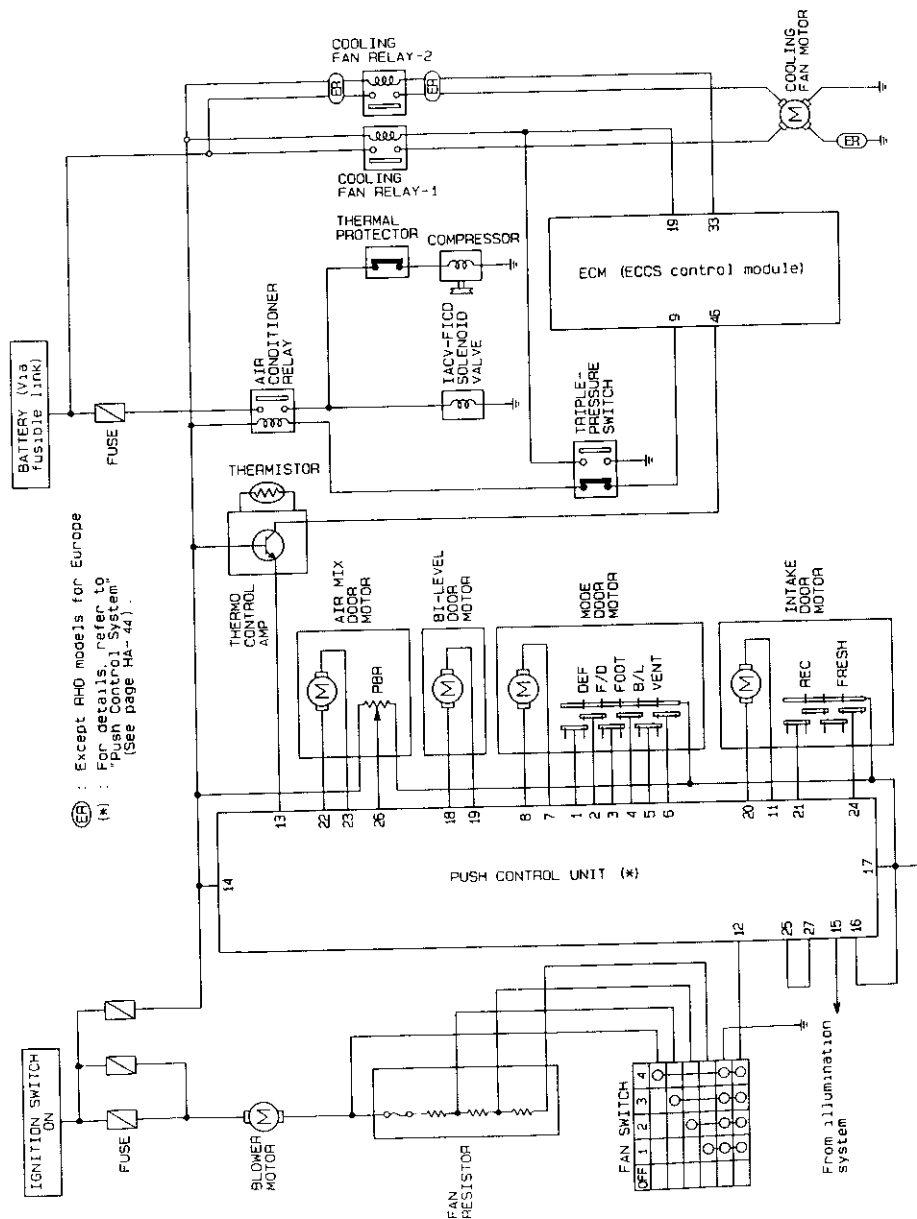

(E) : Except R40 models for Europe  
 (M) : For details, refer to "Push Control Unit System" (See page HA-44).

Circuit Diagram — Push Control Unit

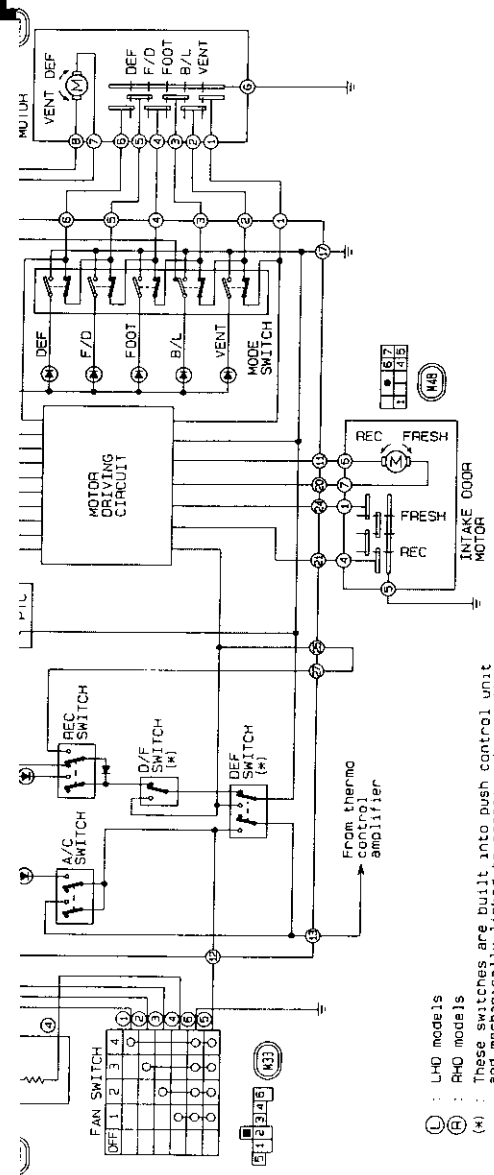

From thermo control amplifier

L : LHD model's  
 R : RHD model's  
 (M) : These switches are built into push control unit and mechanically linked to corresponding switches.

Wiring Diagram — A/C, M —

LHD MODEL

HA-A/C, M-01

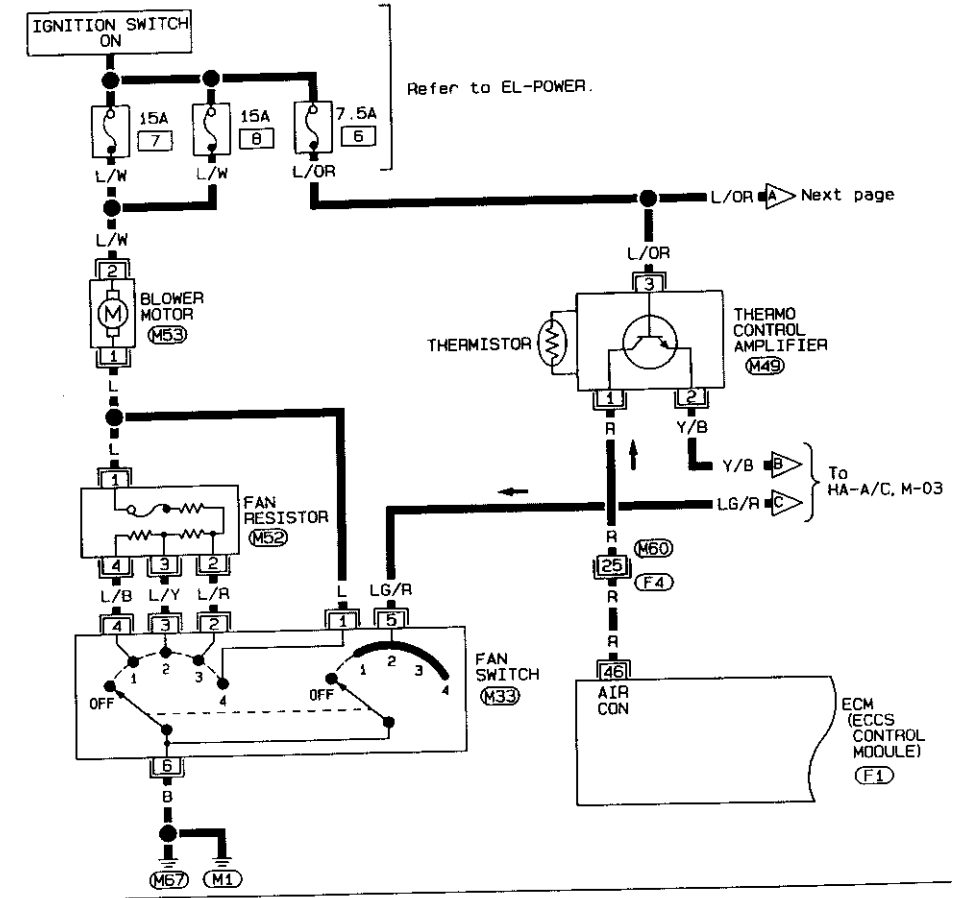

6 4 3 2 1 5 M33 W  
 0 1 2 3 M49 W  
 2 4 1 3 M52 BR  
 2 1 M53 W

Refer to last page (Foldout page).

M60, F4  
F1

Refer to EL-POWER.

Next page

To HA-A/C, M-03

ECM (ECSS CONTROL MODULE) (F1)

HA-A/C, M-02

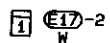
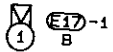
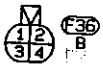
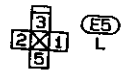
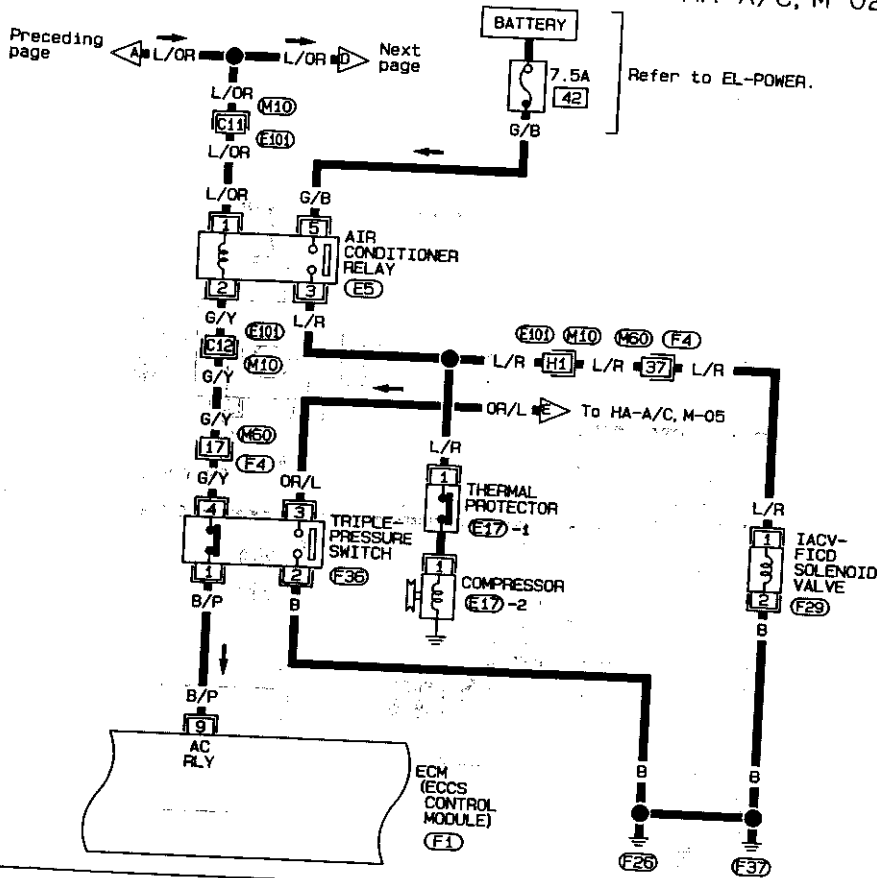

Refer to last page (Foldout page)

(M10, E10)

(M60, F4)

(F1)

HA-A/C, M-03

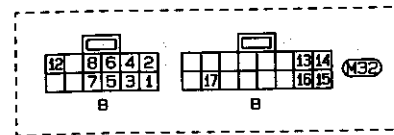
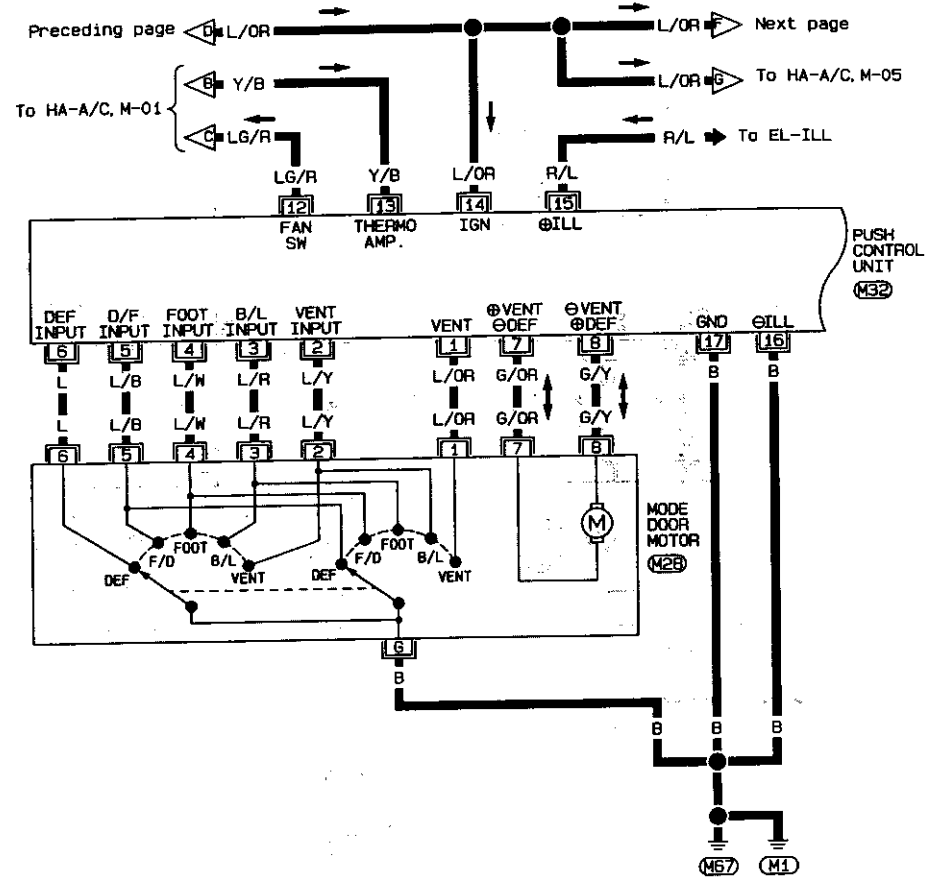

GI  
WA  
EM  
LC  
EC  
FE  
CL  
MT  
AT  
PD  
FA  
RA  
BR  
ST  
RS  
BT  
HA  
EL  
IDX

HA-A/C, M-04

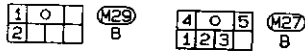
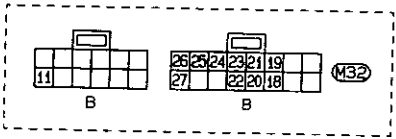
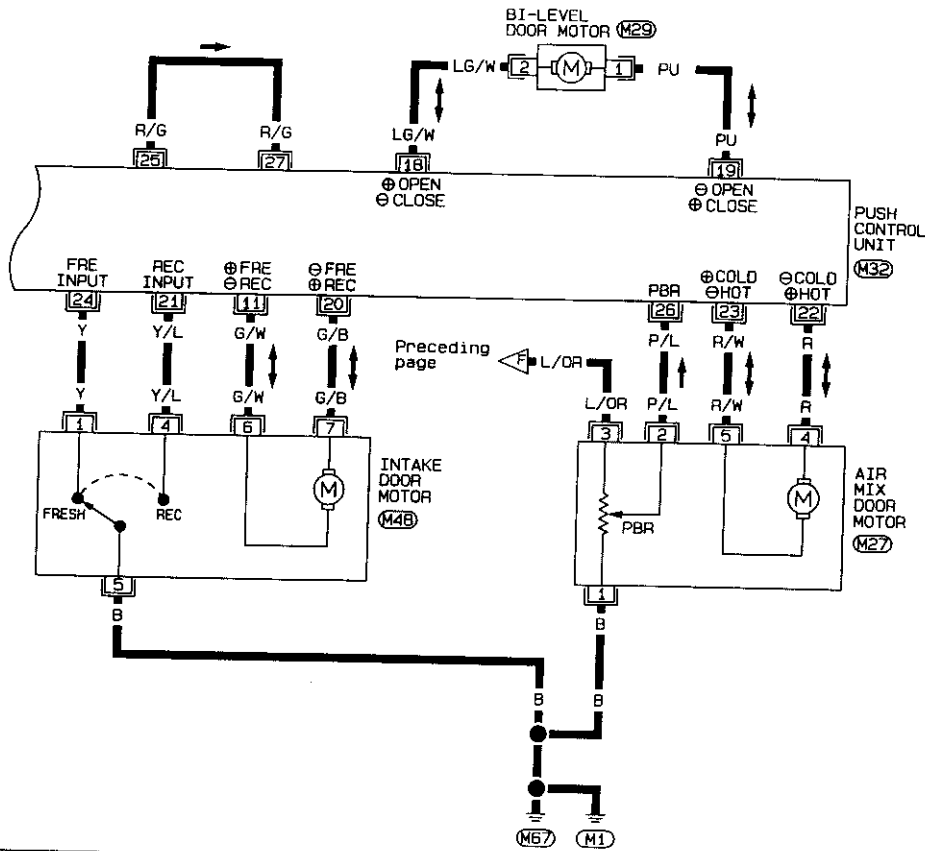

HA-A/C, M-05

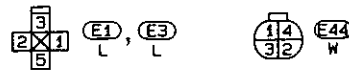
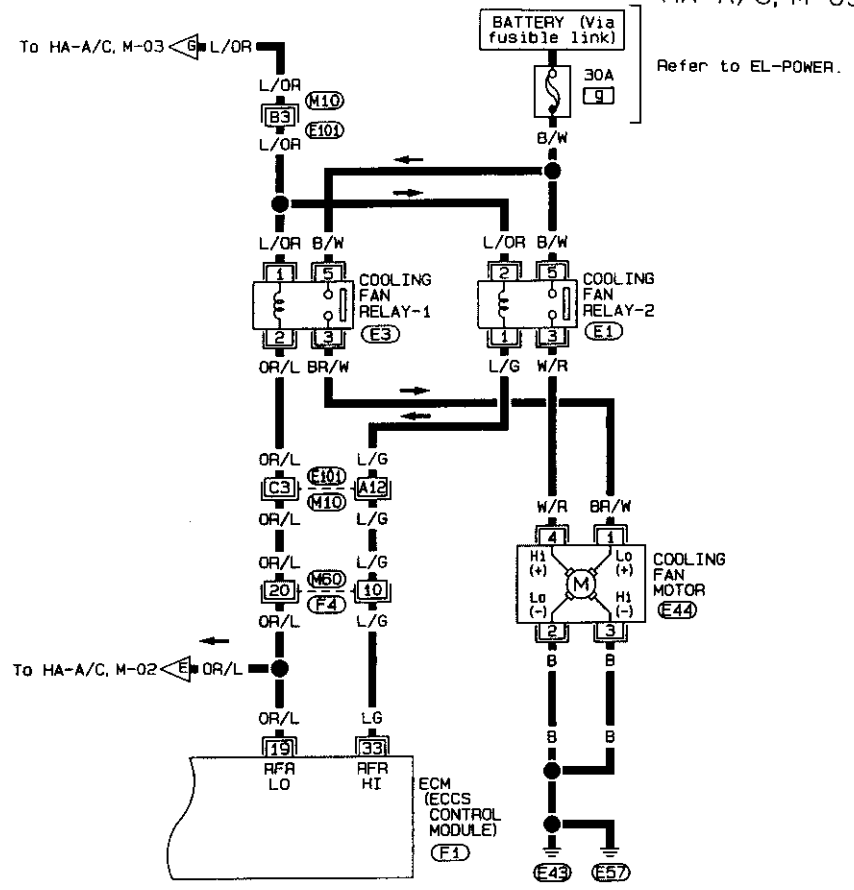

Refer to last page (Foldout page).

- M10, E101
- M50, F4
- F1

3E  
4A  
5M  
6C  
7C  
8E  
9L  
10T  
11D  
12A  
13A  
14A  
15A  
16A  
17A  
18A  
19A  
20A  
21A  
22A  
23A  
24A  
25A  
26A  
27A  
28A  
29A  
30A  
31A  
32A  
33A  
34A  
35A  
36A  
37A  
38A  
39A  
40A  
41A  
42A  
43A  
44A  
45A  
46A  
47A  
48A  
49A  
50A  
51A  
52A  
53A  
54A  
55A  
56A  
57A  
58A  
59A  
60A  
61A  
62A  
63A  
64A  
65A  
66A  
67A  
68A  
69A  
70A  
71A  
72A  
73A  
74A  
75A  
76A  
77A  
78A  
79A  
80A  
81A  
82A  
83A  
84A  
85A  
86A  
87A  
88A  
89A  
90A  
91A  
92A  
93A  
94A  
95A  
96A  
97A  
98A  
99A  
100A

RHD MODEL

HA-A/C, M-06

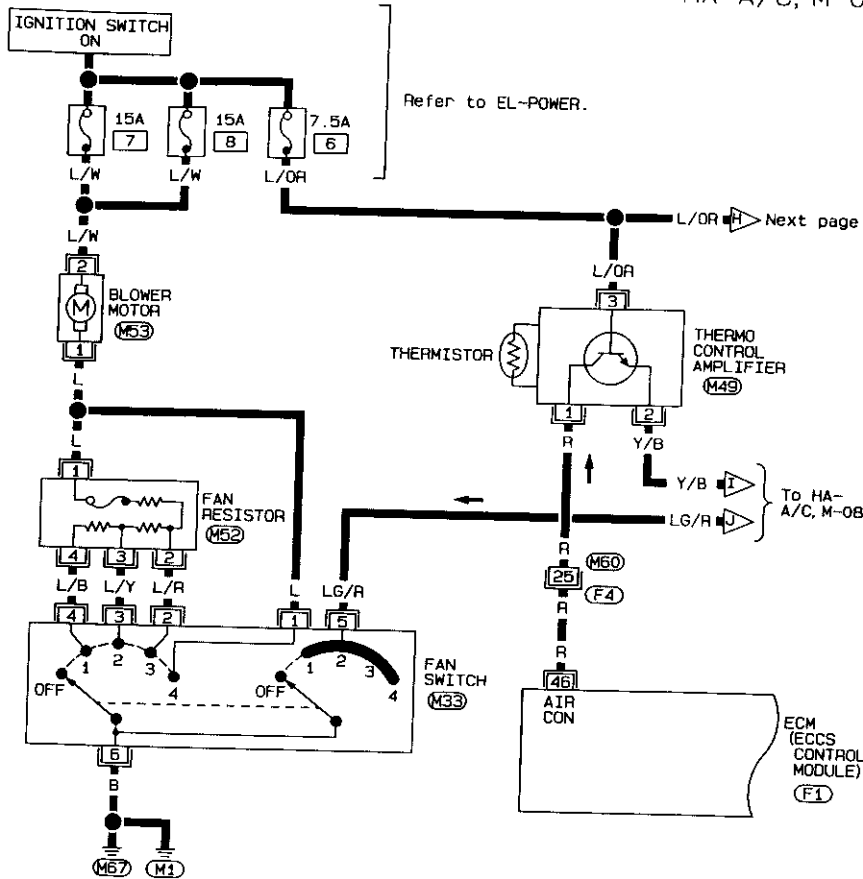

Refer to last page (foldout page).

M50, F4  
F1

HA-A/C, M-07

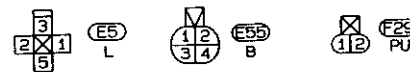
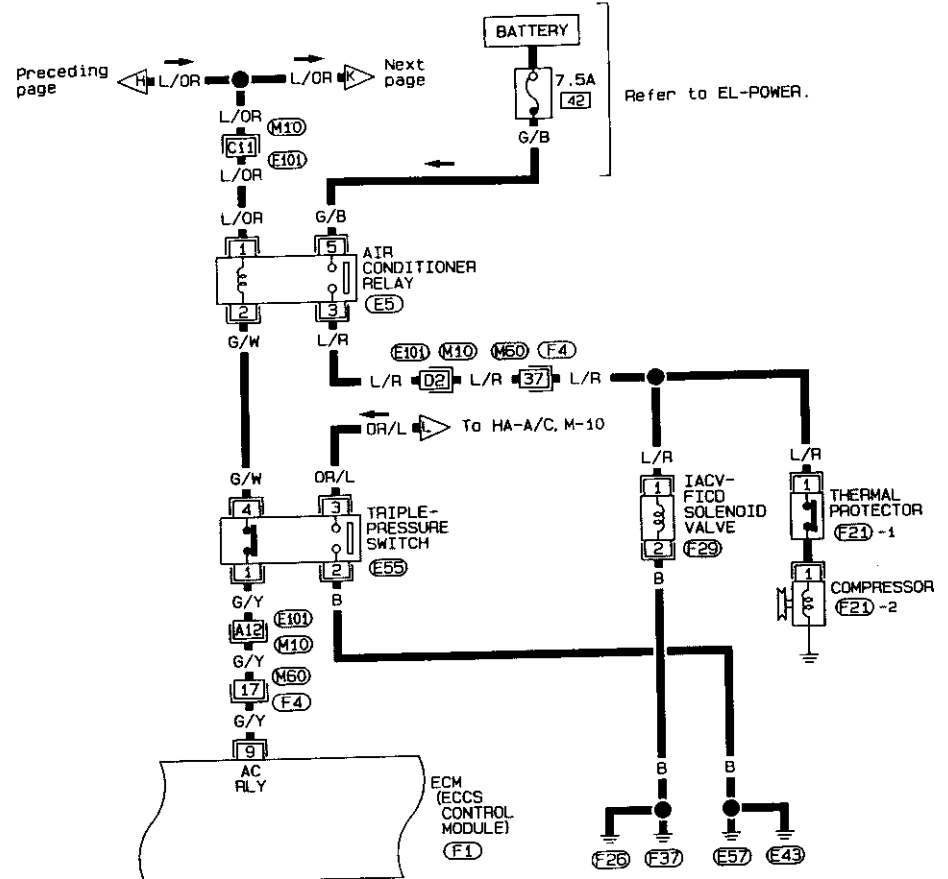

Refer to last page (foldout page).

M10, E101  
M50, F4  
F1

Wiring Diagram — A/C, M — (Cont'd)

HA-A/C, M-08

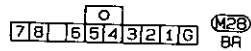
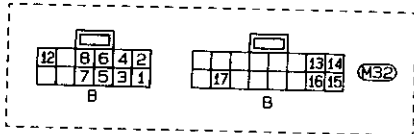
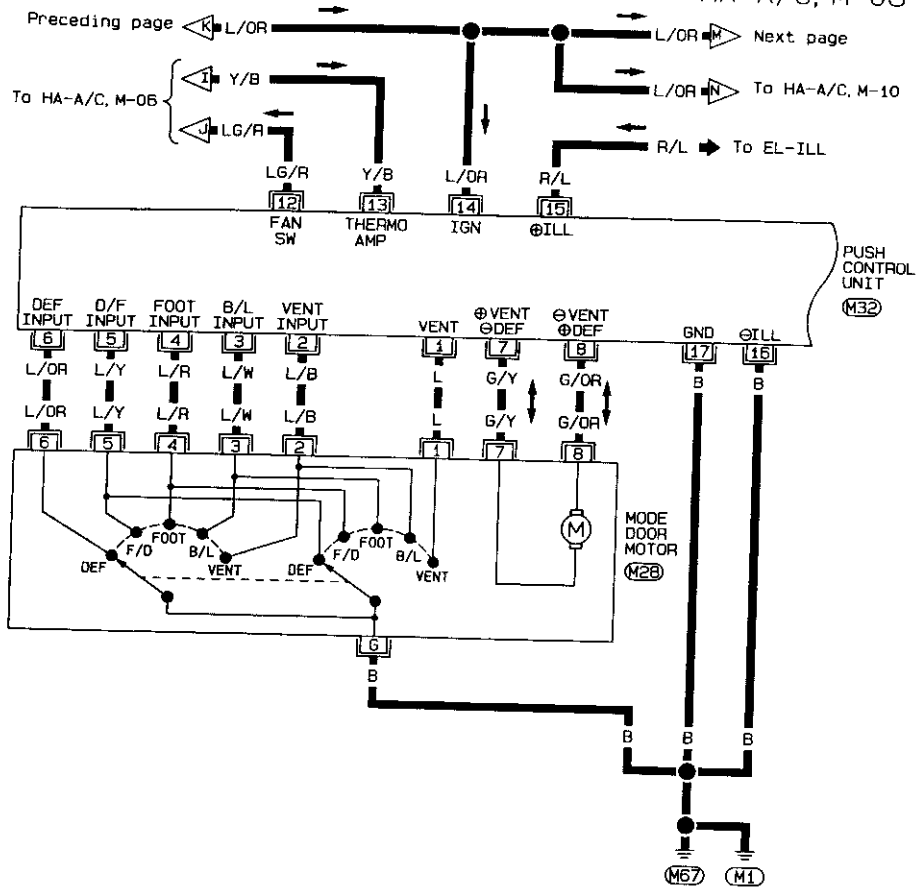

Wiring Diagram — A/C, M — (Cont'd)

HA-A/C, M-09

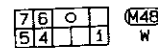
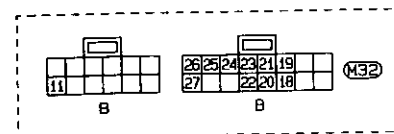
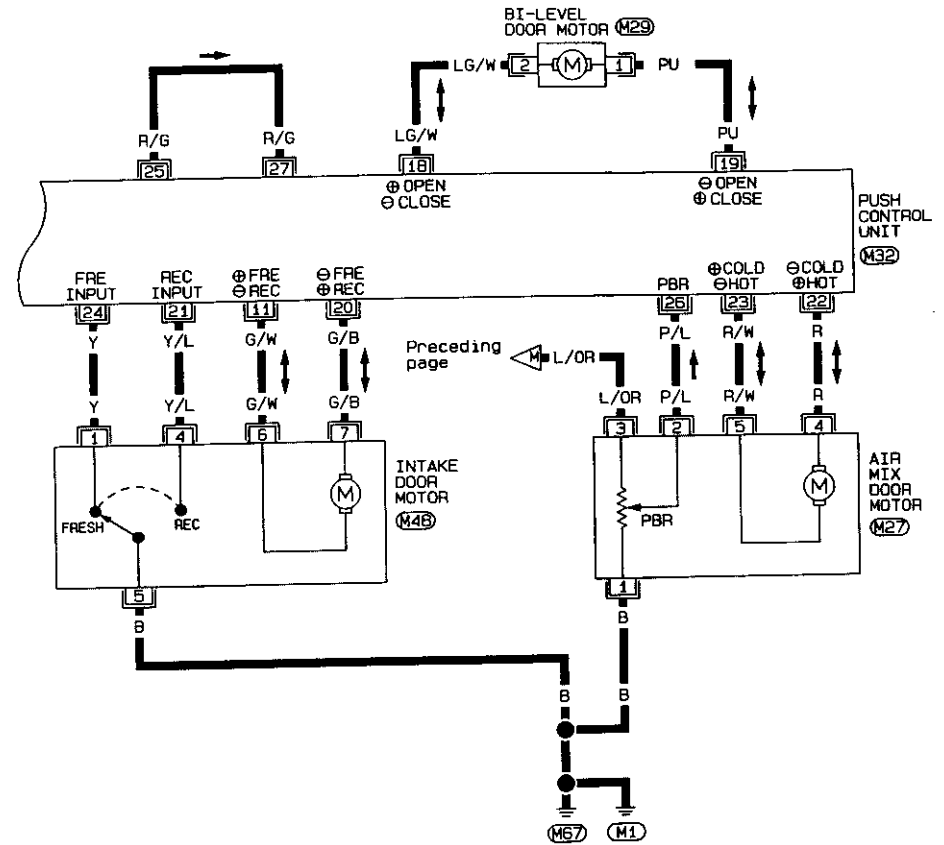

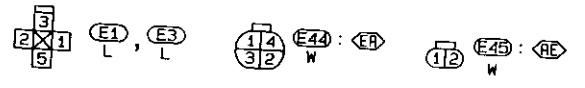
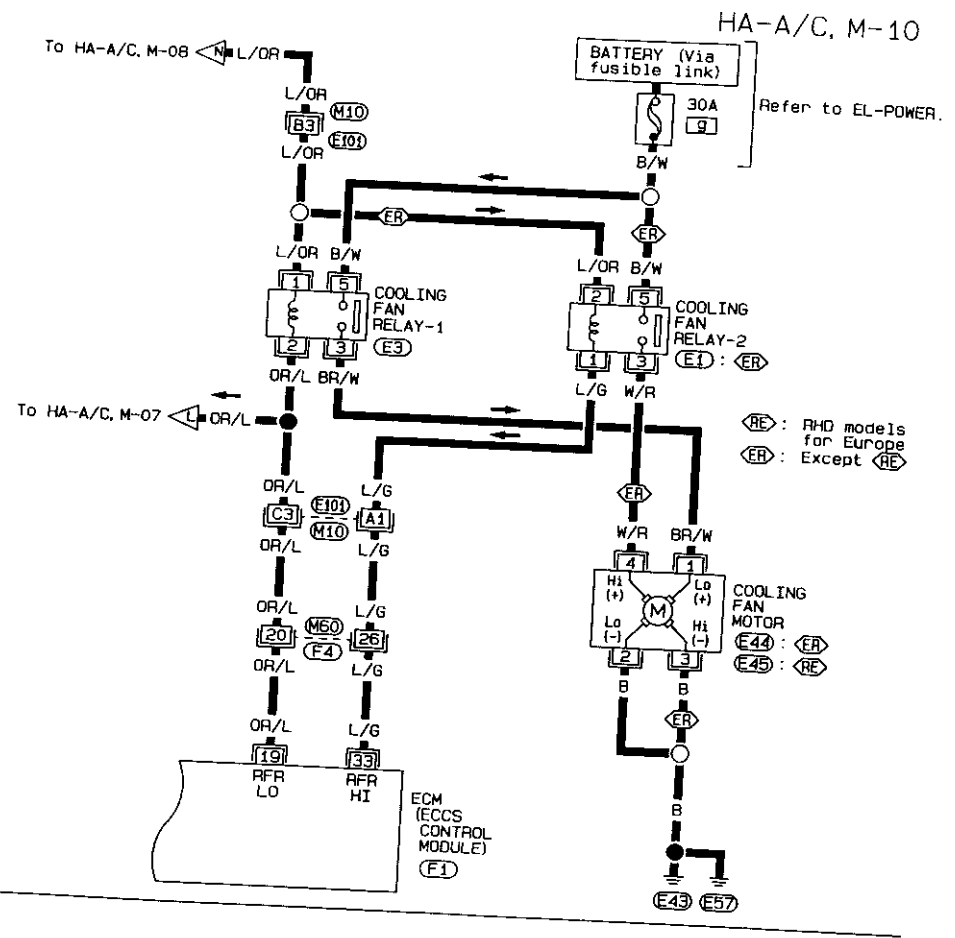

Refer to last page (Foldout page).

- (M10), (E10)
- (M60), (F4)
- (F1)

Main Power Supply and Ground Circuit Check

POWER SUPPLY CIRCUIT CHECK

Check power supply circuit for air conditioning system. Refer to EL section ("Wiring Diagram", "POWER SUPPLY ROUTING").

PUSH CONTROL UNIT CHECK

Check power supply circuit for push control unit with ignition switch at ON.

1. Disconnect push control unit harness connector.
2. Connect voltmeter from harness side.
3. Measure voltage across terminal No. 14 and body ground.

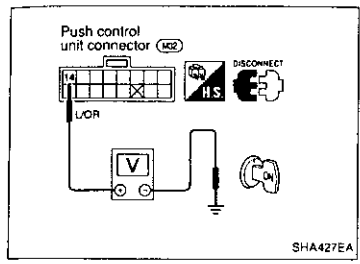

Voltmeter terminal		Voltage
+	-	
14	Body ground	Approx. 12V

Check body ground circuit for push control unit.

1. Disconnect push control unit harness connector.
2. Connect ohmmeter from harness side.
3. Check for continuity between terminal No. 17 and body ground.

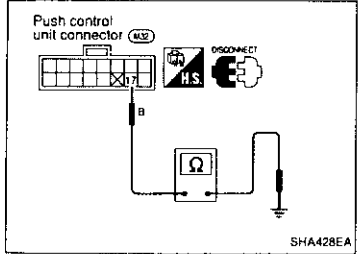

Ohmmeter terminal		Continuity
+	-	
17	Body ground	Yes



INCIDENT	Flow chart No.
1 Fan fails to rotate.	1
2 Fan does not rotate at 1-speed.	2
3 Fan does not rotate at 2-speed.	3
4 Fan does not rotate at 3-speed.	4
5 Fan does not rotate at 4-speed.	5

Diagnostic Procedure 1

**SYMPTOM: Blower motor does not rotate.**  
 • Perform **PRELIMINARY CHECK 2** before referring to the following flow chart.

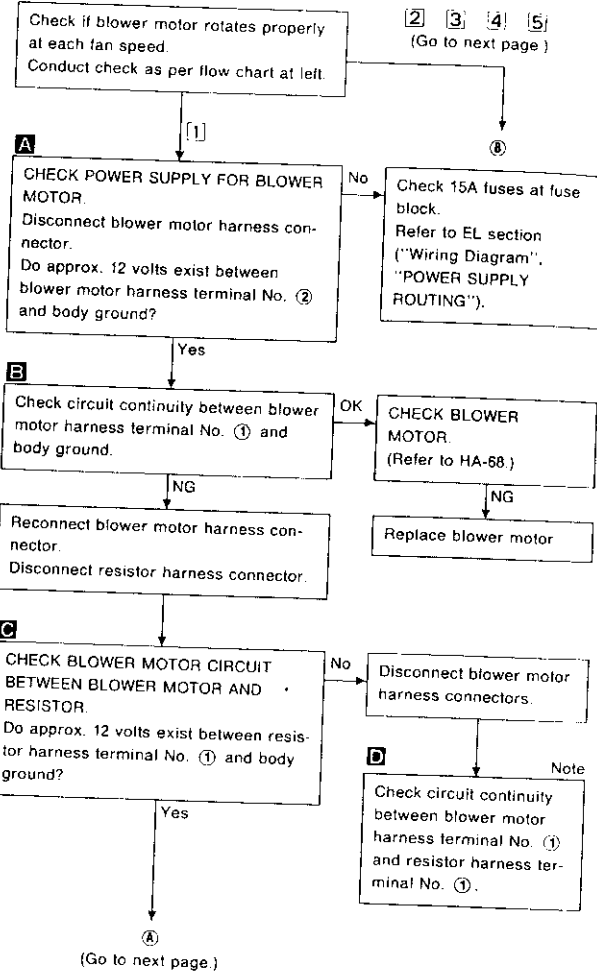

**Note:**  
 If the result is NG after checking circuit continuity, repair harness or connector.

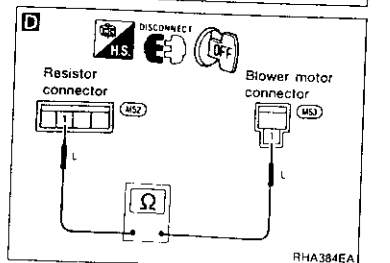
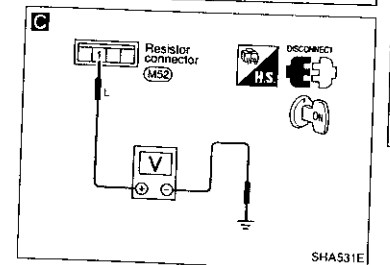
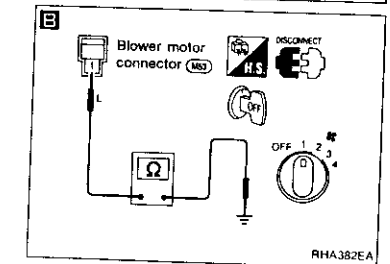
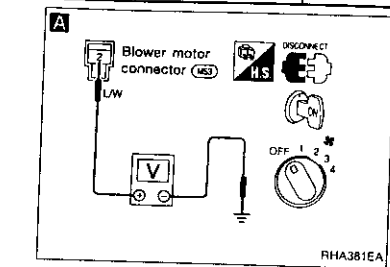

Diagnostic Procedure 1 (Cont'd)

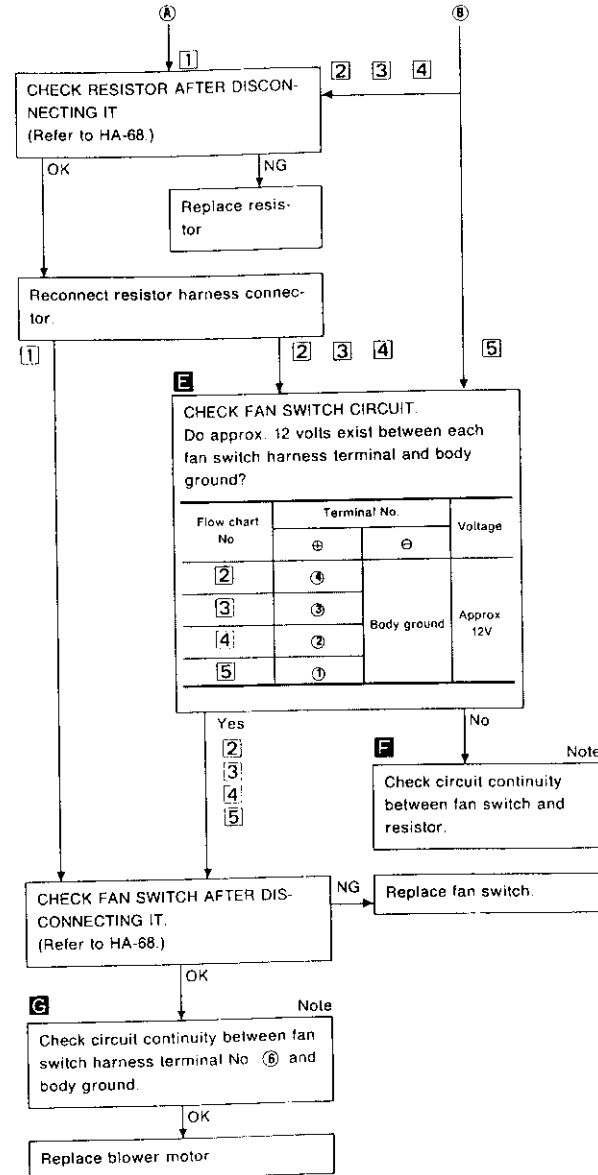
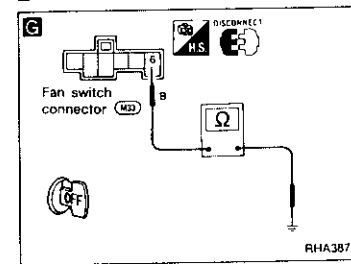
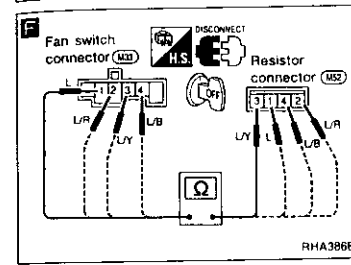
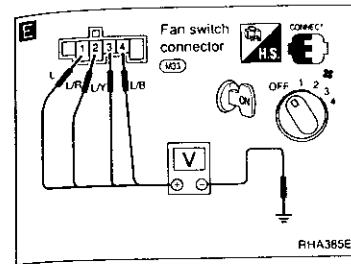

Flow chart No.	Terminal No.		Voltage
	⊕	⊖	
2	2	⊖	Approx 12V
3	3	⊖	
4	4	⊖	
5	1	⊖	
		Body ground	

**Note:**  
 If the result is NG after checking circuit continuity, repair harness or connector.

Diagnostic Procedure 2

**SYMPTOM: Air outlet does not change.**

- Perform PRELIMINARY CHECK 4, then Main Power Supply and Ground Circuit Check before referring to the flow chart below.

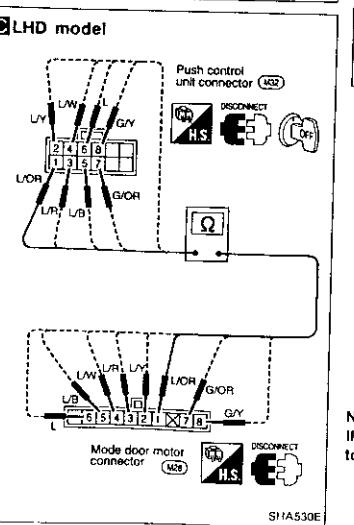
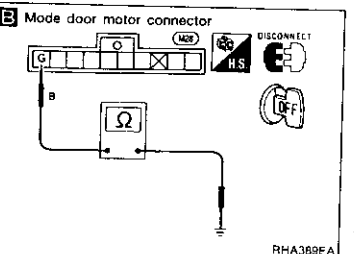
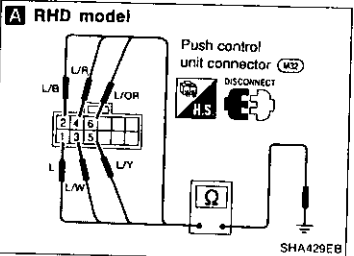
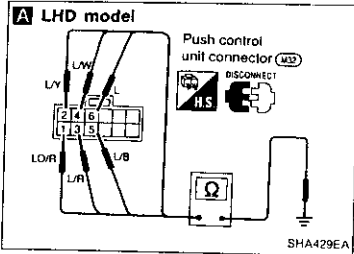

**A** CHECK MODE DOOR MOTOR POSITION SWITCH.

- Turn VENT switch ON with ignition switch at ON position.
- Turn ignition switch OFF. Disconnect push control unit connector.
- Check for continuity between terminal ① or ② of push control unit harness connector and body ground.
- Using above procedures, check for continuity in any other mode, as indicated in chart.

Mode switch	Terminal No		Continuity
	⊕	⊖	
VENT	① or ②	Body ground	Yes
B/L	② or ③		
FOOT	③ or ④		
F/D	④ or ⑤		
DEF	⑤ or ⑥		

**C** CHECK SIDE LINK.  
Refer to Control Linkage Adjustment (HA-70)

NG Disconnect mode door motor harness connector.

**B** CHECK BODY GROUND CIRCUIT FOR MODE DOOR MOTOR.  
Does continuity exist between mode door motor harness terminal No. ⑥ and body ground?

**C** Check circuit continuity between each terminal on push control unit and on mode door motor.

Terminal No.	Continuity	
	⊕	⊖
Push control unit	Mode door motor	Yes
①	①	
②	②	
③	③	
④	④	
⑤	⑤	
⑦	⑦	
⑧	⑧	

OK  
Ⓐ (Go to next page)

Note: If the result is NG after checking circuit continuity, repair harness or connector.

Diagnostic Procedure 2 (Cont'd)

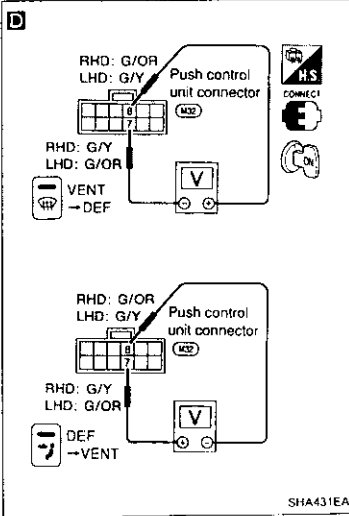
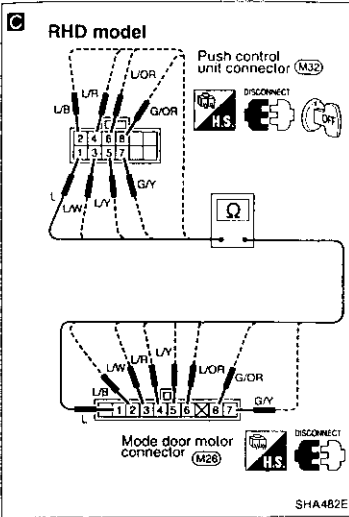

Ⓐ Reconnect push control unit and mode door motor harness connectors.

**D** CHECK FOR OUTPUT OF PUSH CONTROL UNIT.  
Change the mode from VENT to DEF, or from DEF to VENT. Do approx. 12 volts exist between push control unit harness terminals ⑦ and ⑧ in both cases?

Terminal No.	Mode switch operation	Voltage
⑦ ⑧	Each side Stop	0V
⊖ ④	VENT → DEF	Approx 12V
④ ⊖	DEF → VENT	

Yes  
Replace mode door motor.

No  
Replace push control unit.

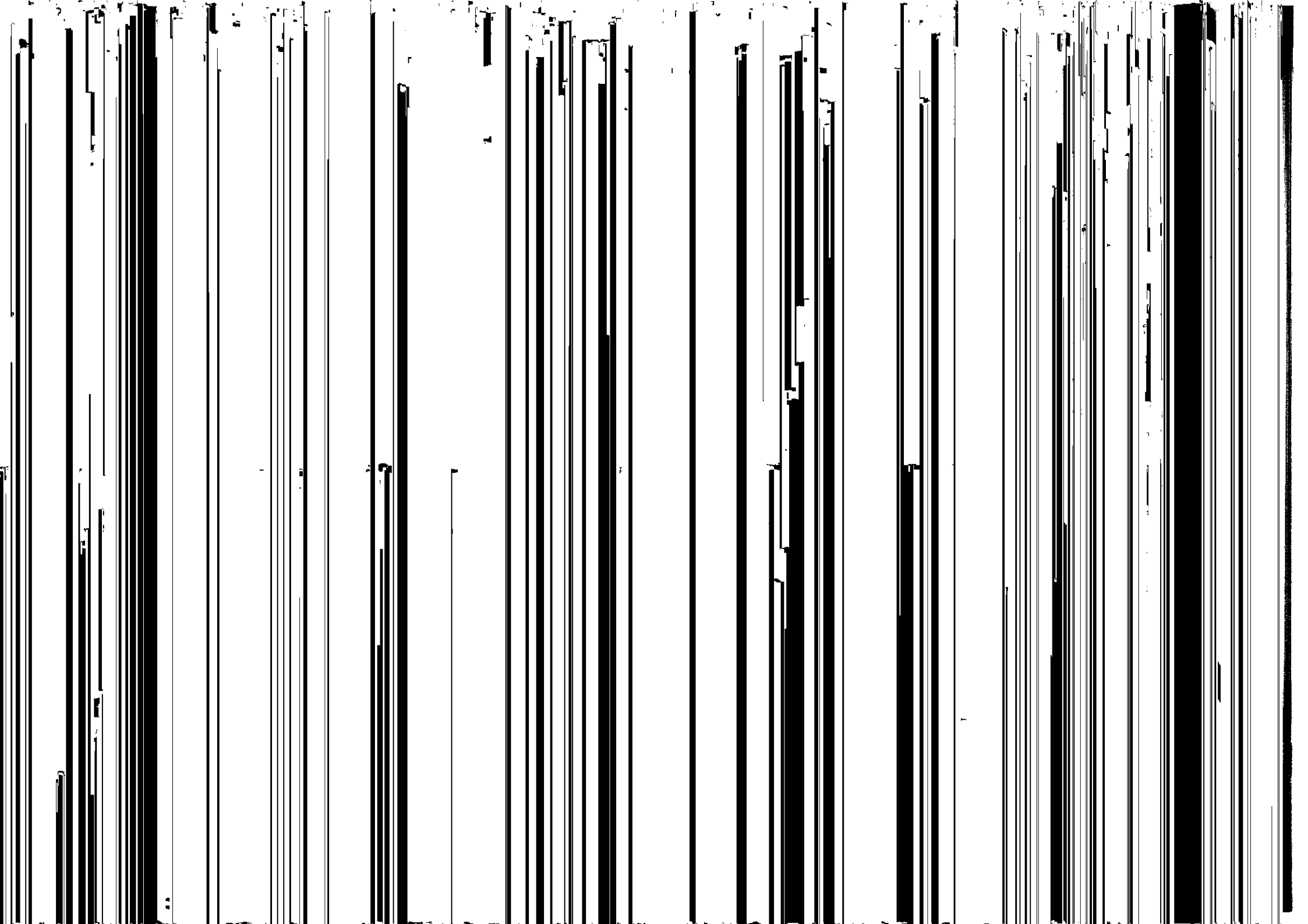

Diagnostic Procedure 4 (Cont'd)

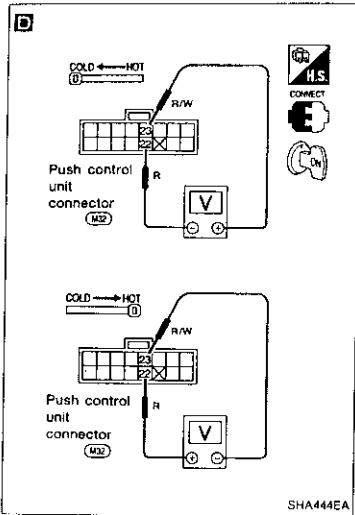

SHA444EA

**D** CHECK FOR PUSH CONTROL UNIT OUTPUT.  
Slide the temperature control lever from HOT to COLD and COLD to HOT. Do approx. 12 volts exist between push control unit harness terminals ② and ③ in both cases?

Terminal No.	Temp control lever operation	Voltage
②	③	HOT → COLD
①	②	COLD → HOT
Each side	STOP	Approx 0V

No → Replace push control unit.

Yes → CHECK FOR PBR RESISTANCE IN AIR MIX DOOR MOTOR. Refer to HA-70.

NG → Replace air mix door motor.

OK → CHECK AIR MIX DOOR LINK. (Refer to HA-71.)

Diagnostic Procedure 5

SYMPTOM: Bi-level (B/L) door does not operate.

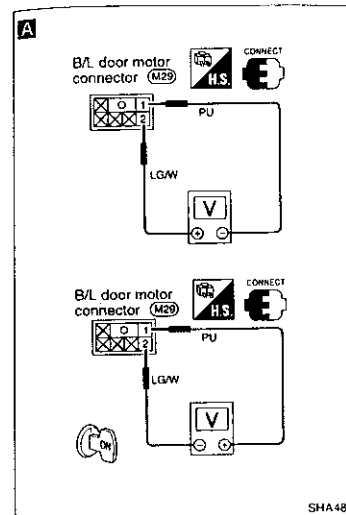

SHA489E

**A** CHECK POWER SUPPLY FOR B/L DOOR MOTOR.  
Turn B/L switch ON and OFF. Do approx. 12 volts exist between B/L door motor harness terminals ① and ② in both cases?

Terminal No.	B/L switch	B/L door operation	Voltage
②	①	ON	Open
①	②	OFF	Close
②	①	ON	Approx 12V
①	②	OFF	Approx 12V

No → Disconnect push control unit connector.

**B** Check circuit continuity between B/L door motor harness terminal No. ② (①) and push control unit harness terminal No. ⑩ (⑨).

OK → Replace push control unit.

Yes → CHECK B/L DOOR LINK. Refer to HA-71.

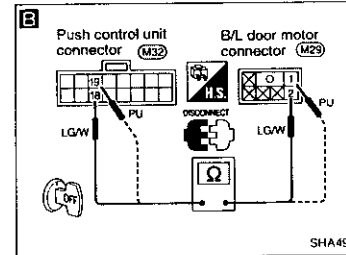

SHA490E

**Note:** If the result is NG after checking circuit continuity, repair harness or connector.

## Diagnostic Procedure 6

**SYMPTOM:** Magnet clutch does not operate when A/C switch and fan switch are ON.

- Perform PRELIMINARY CHECK 2 before referring to the following flow chart.

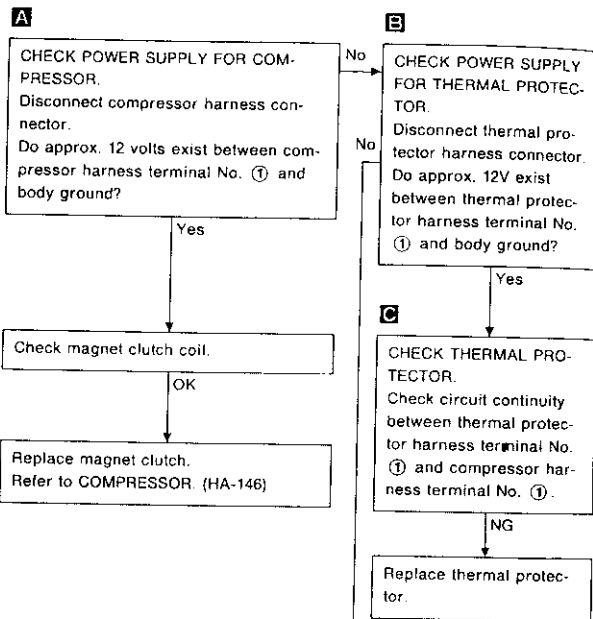
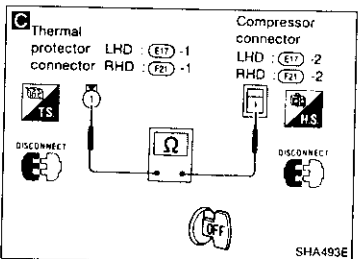
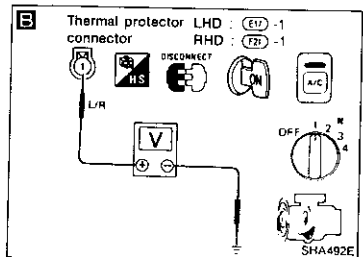
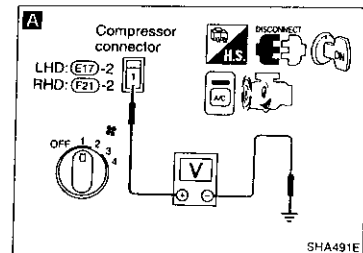

(Go to next page.)

## Diagnostic Procedure 6 (Cont'd)

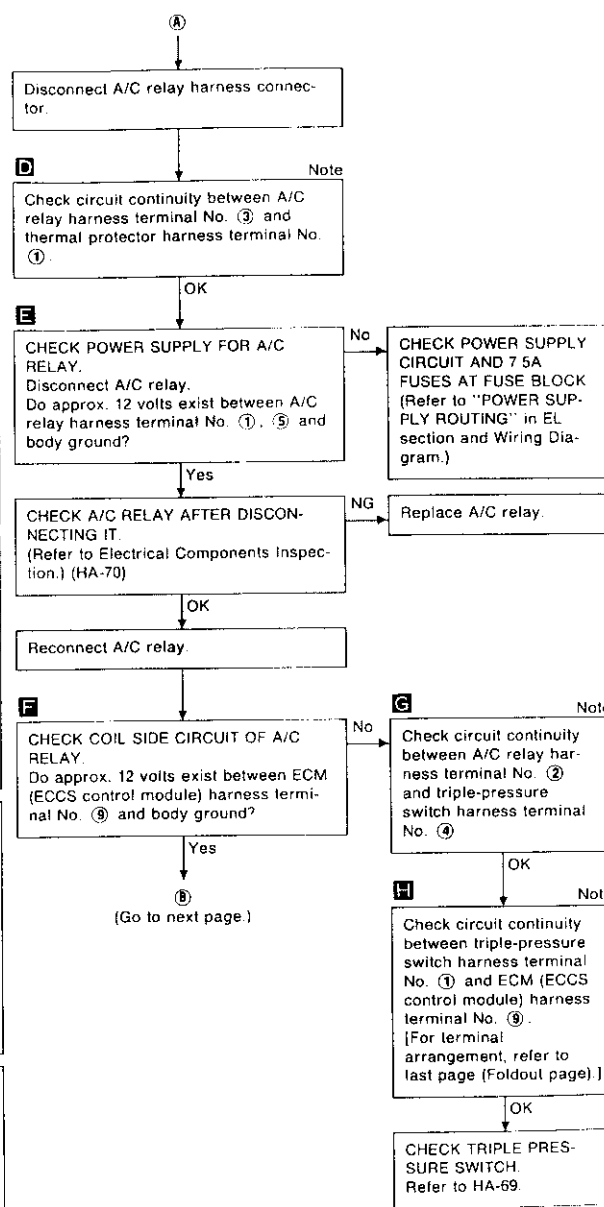
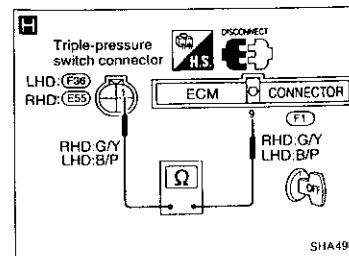
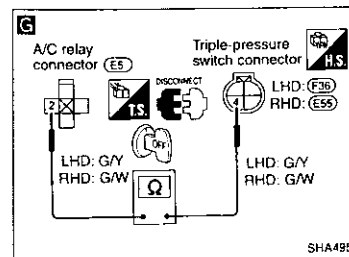
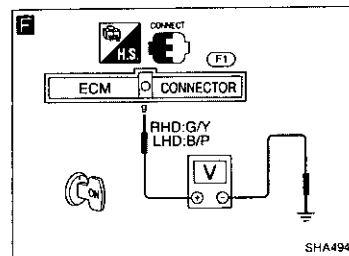
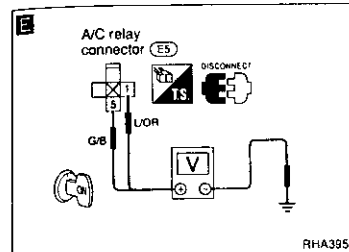
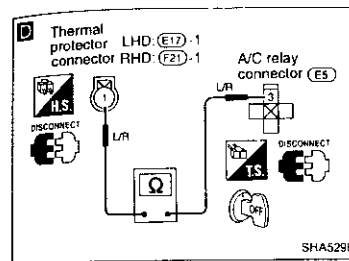

Note:  
If the result is NG after checking circuit continuity, repair harness or connector.

Procedure 6 (Cont'd)

ol amp. har-

Note  
between thermo  
terminal No. ①  
(module) har-

FOR THERMO No  
ol amp. har-  
between  
harness terminal  
? Check 7.5A fuse at fuse  
block  
Refer to EL section  
("Wiring Diagram",  
"POWER SUPPLY  
ROUTING").

CIRCUIT FOR  
switch ON.  
between thermo  
terminal ② and  
? Disconnect push control  
unit harness connector.  
Ⓢ  
(Go to next page.)

OL AMP. NG Replace thermo control  
amp.

GM (ECCS  
terminals ③).  
VI Terminals  
TROUBLE  
Description").

After checking circuit continuity, repair har-

Diagnostic Procedure 6 (Cont'd)

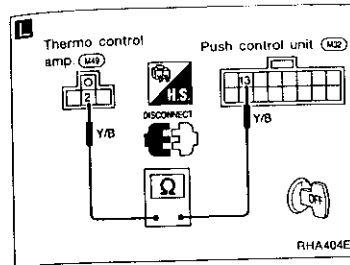

Note  
Check circuit continuity between thermo  
control amp. harness terminal No. ②  
and push control unit harness terminal  
No. ⑬.

OK  
Disconnect fan switch harness connec-  
tor.

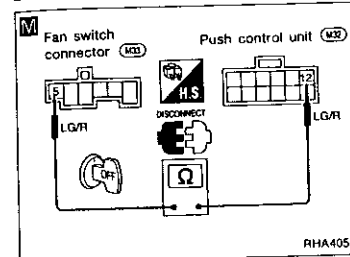

Note  
Check circuit continuity between push  
control unit terminal No. ⑫ and fan  
switch harness terminal No. ⑤.

Note  
CHECK BODY GROUND CIRCUIT FOR  
FAN SWITCH.  
Check for continuity between fan switch  
harness terminal ⑥ and body ground.

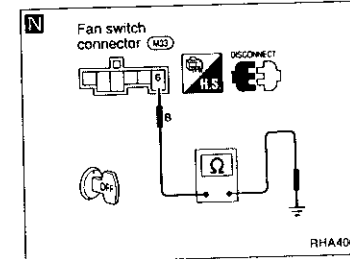

OK  
CHECK FAN SWITCH.  
(Refer to HA-68.) NG Replace fan switch.

OK  
Replace push control unit.

Note:  
If the result is NG after checking circuit continuity, repair har-  
ness or connector.

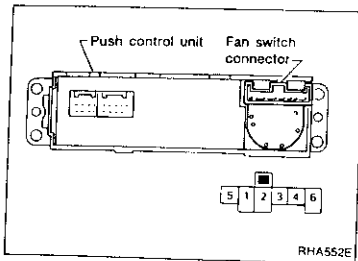

## Electrical Components Inspection

## FAN SWITCH

Check continuity between terminals at each position.

POSITION	TERMINAL
OFF	
1	④ - ⑤ - ⑥
2	③ - ⑤ - ⑥
3	② - ⑤ - ⑥
4	① - ⑤ - ⑥

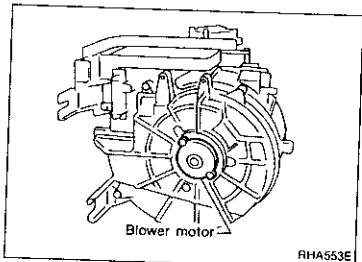

## BLOWER MOTOR

Check blower motor for smooth rotation.

- Ensure that there are no foreign particles inside the intake unit.

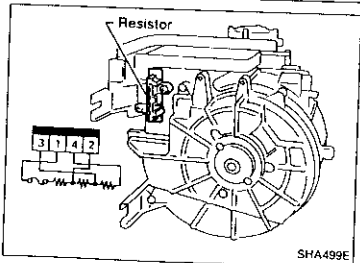

## BLOWER RESISTOR

Check continuity between terminals.

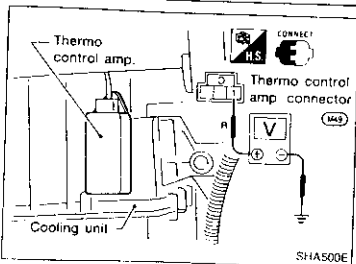

## THERMO CONTROL AMP.

- Run engine, and operate A/C system.
- Connect the voltmeter from harness side.
- Check thermo control amp. operation shown in the table.

Evaporator outlet air temperature °C (°F)	Thermo amp operation	Tester
Decreasing to 2.5 - 3.5 (37 - 38)	Turn OFF	Approx. 12V
Increasing to 1 - 2 (34 - 36)	Turn ON	Approx. 0V

## Electrical Components Inspection (Cont'd)

## TRIPLE-PRESSURE SWITCH

## LHD model

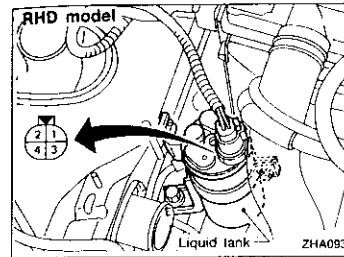
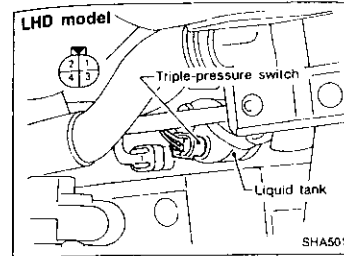

	Terminals	High-pressure side line pressure kPa (bar, kg/cm <sup>2</sup> , psi)	Operation	Continuity
Low-pressure side	① - ④	Increasing to 157 - 226 (1.57 - 2.26, 1.6 - 2.3, 23 - 33)	ON	Exist
		Decreasing to 152.0 - 201.0 (1.520 - 2.010, 1.55 - 2.05, 22.0 - 29.2)	OFF	Does not exist
Medium-pressure side*	② - ③	Increasing to 1,422 - 1,618 (14.22 - 16.18, 14.5 - 16.5, 206 - 235)	ON	Exist
		Decreasing to 1,128 - 1,422 (11.28 - 14.22, 11.5 - 14.5, 164 - 206)	OFF	Does not exist
High-pressure side	① - ④	Increasing to 1,667 - 2,059 (16.7 - 20.6, 17 - 21, 242 - 299)	ON	Exist
		Decreasing to 2,452 - 2,844 (24.5 - 28.4, 25 - 29, 356 - 412)	OFF	Does not exist

\* For cooling fan motor operation.

## RHD model

	Terminals	High-pressure side line pressure kPa (bar, kg/cm <sup>2</sup> , psi)	Operation	Continuity
Low-pressure side	① - ④	Increasing to 157 - 216 (1.57 - 2.16, 1.6 - 2.2, 23 - 31)	ON	Exists.
		Decreasing to 152.0 - 201.0 (1.520 - 2.010, 1.55 - 2.05, 22.0 - 29.2)	OFF	Does not exist.
Medium-pressure side*	② - ③	Increasing to 1,442 - 1,697 (14.42 - 16.97, 14.7 - 17.3, 209 - 246)	ON	Exists
		Decreasing to 1,128 - 1,422 (11.28 - 14.22, 11.5 - 14.5, 164 - 206)	OFF	Does not exist.
High-pressure side	① - ④	Decreasing to 1,275 - 1,667 (12.7 - 16.7, 13 - 17, 185 - 242)	ON	Exists.
		Increasing to 2,452 - 2,844 (24.5 - 28.4, 25 - 29, 356 - 412)	OFF	Does not exist.

\* For cooling fan motor operation.

**Linkage Adjustment (Cont'd)**

**DOOR**

r mix door link by hand and hold air mix door in  
 position.  
 r mix door motor on heater unit and connect sub-  
 ition switch to ON.  
 mperature control lever to full cold.  
 r mix door motor rod to air mix door link rod  
 hat air mix door operates properly when tempera-  
 trol lever is slid to full hot and full cold.  
 mperature control lever to full cold.

CI  
 VA  
 EM  
 LC

**DOOR**

intake door motor harness connector before  
 g intake door motor.  
 ition switch to ON.  
 C switch ON.  
 ttake door motor on intake unit.  
 ke door rod in REC position and fasten door rod to  
 hat intake door operates properly when REC switch  
 d ON and OFF.

EC  
 EH  
 CL  
 MT  
 AT  
 PD  
 PA

**B/L) DOOR**

B/L door motor harness connector before install-  
 door motor.  
 ition switch to ON.  
 /L door motor on heater unit.  
 hat B/L door operates properly when bi-level  
 is turned ON and OFF.

BR  
 ST  
 RS

BT

HA

EL

DX



### Introduction

The Automatic Temperature Control (ATC) system provides automatic regulation of the vehicle's interior temperature. The operator selects "set temperature", on which the regulation is based, regardless of the outside temperature changes. This is done by utilizing a microcomputer, also referred to as the automatic amplifier (auto amp.), which receives input signals from several sensors. The automatic amplifier uses these input signals (including the set temperature) to automatically control the ATC system's outlet air volume, air temperature, and air distribution.

### Features

#### Air mix door control (Automatic temperature control)

The air mix door is automatically controlled so that in-vehicle temperature is maintained at a predetermined value by: The temperature setting, ambient temperature, in-vehicle temperature and amount of sunload.

#### Fan speed control

Blower speed is automatically controlled based on temperature setting, ambient temperature, in-vehicle temperature, amount of sunload and air mix door position.

With FAN switch set to "AUTO", the blower motor starts to gradually increase air flow volume.

When engine coolant temperature is low, the blower motor operation is delayed to prevent cool air from flowing.

#### Intake door control

The intake doors are automatically controlled by: The temperature setting, ambient temperature, in-vehicle temperature and amount of sunload.

#### Mode door control

The mode doors (defroster door, ventilator door and foot door) are automatically controlled by: The temperature setting, ambient temperature, in-vehicle temperature and amount of sunload.

#### Bi-level door control

The bi-level door is opened to increase amount of air discharge when the air discharge outlet is set at bi-level position. The bi-level door is also opened when the fan speed is high and the set temperature is at 18°C.

Except during the above conditions, the bi-level door is closed.

#### Self-diagnostic system

The self-diagnostic system is built into the automatic amplifier to quickly locate the cause of problems.

### Control Operation

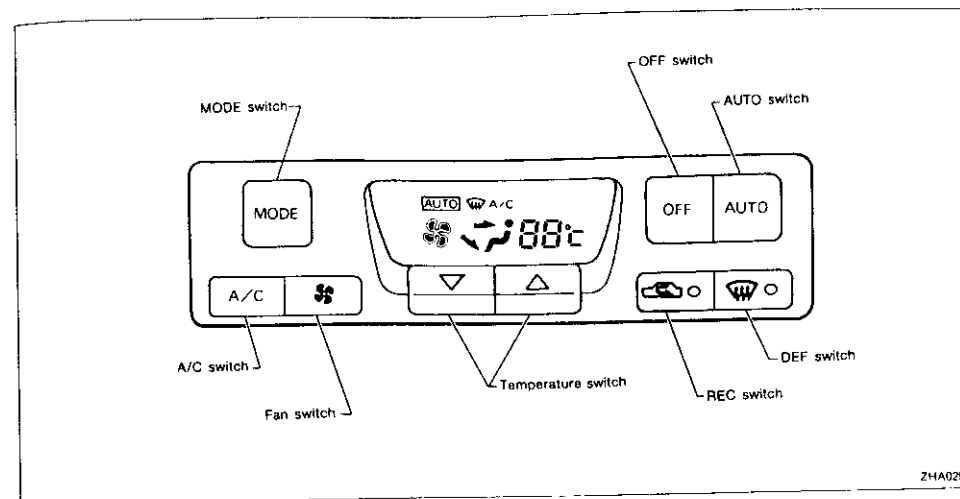

#### AUTO SWITCH

The compressor, air intake doors, air mix door, mode doors, and blower speed are automatically controlled so that the in-vehicle temperature will reach, and be maintained at the set temperature.

**The air conditioning cooling function operates only when the engine is running.**

#### A/C SWITCH

Manual control of the compressor operation. When the A/C mark appears on the display screen, compressor operation is being carried out.

#### TEMPERATURE SWITCH





Increases or decreases the set temperature.

#### OFF SWITCH

The compressor and blower are off, the air intake doors are set to the outside air position. Then, the mode doors are set to the foot (80% foot and 20% defrost) position. In the off position the ATC system uses the vehicle's "flow through" ventilation. It tries to maintain the interior temperature based on the last set temperature of the system.





#### FAN SWITCH

Manual control of the blower speed. Four speeds are available for manual control (as shown on the display screen):

low , medium low , medium high , high 

#### MODE SWITCH

Manual control of the air discharge outlets. Four selections are available (as shown on the display screen):

face , bi-level , foot , defrost/foot 

DESCRIPTION

AUTO

Control Operation (Cont'd)

REC SWITCH

ON position: Interior air is recirculated inside the vehicle.  
OFF position: Automatic control resumes.  
RECIRC is canceled when DEF is selected. RECIRC resumes when another mode is chosen.

DEF SWITCH

Positions the mode doors to the defrost position. Also positions the air intake doors to the outside air position. With DEF switch ON, the compressor operates.

DESCRIPTION

AUTO

NOTE

SI  
MA  
EM  
LC  
EC  
EE  
CL  
MT  
AT  
PD  
EA  
RA  
RN  
ST  
RS  
RY  
HA  
EL  
EX

..... HA- 78

..... HA- 79

..... HA- 82

..... HA- 84

..... HA- 85

..... HA- 88

..... HA- 88

..... HA- 89

..... HA- 90

..... HA- 90

..... HA- 92

..... HA- 93

..... HA- 93

..... HA- 94

..... HA- 95

..... HA- 96

..... HA- 97

..... HA- 98

..... HA- 99

..... HA-100

..... HA- 26

..... HA- 28

..... HA- 29

..... HA-101

..... HA-103

..... HA-104

..... HA-110

agnosis STEP 2.) ..... HA-111

agnosis STEP 2.) ..... HA-112

agnosis STEP 2.) ..... HA-113

agnosis STEP 2.) ..... HA-114

..... HA-115

..... HA-117

Contents (Cont'd)

**Diagnostic Procedure 7**  
 SYMPTOM: Air mix door motor does not operate normally. .... HA-118

**Diagnostic Procedure 8**  
 SYMPTOM: Bi-level (B/L) door motor does not operate normally. .... HA-119

**Diagnostic Procedure 9**  
 SYMPTOM: Blower motor operation is malfunctioning under out of Starting Fan Speed Control. .... HA-120

**Diagnostic Procedure 10**  
 SYMPTOM: Magnet clutch does not engage after performing Preliminary Check 6. .... HA-122

**Control Linkage Adjustment** ..... HA-125

BT

WA

EW

LC

EC

EE

CL

WT

BY

PC

PA

WA

SP

BT

BT

HA

EL

ED

How to Perform Trouble Diagnoses for Quick and Accurate Repair

WORK FLOW

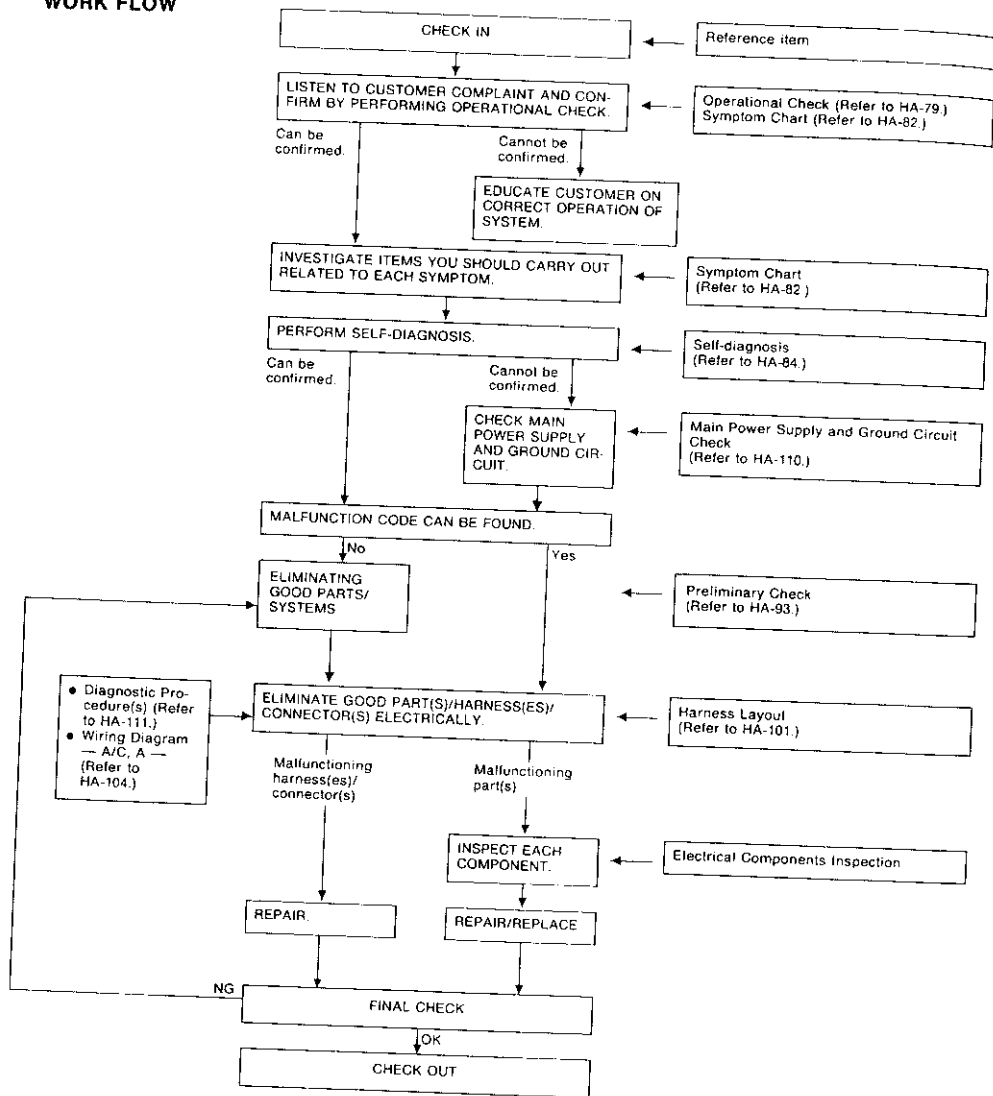

Operational Check

The purpose of the operational check is to confirm that the system is as it should be. The systems which will be checked are the blower, mode (discharge air), intake air, temperature decrease, temperature increase, A/C switch and the memory function.

CONDITIONS:

- Engine running and at normal operating temperature.

PROCEDURE:

1. Check blower

- 1) Press fan switch one time. Blower should operate on low speed. The fan symbol should have one blade lit.
- 2) Press fan switch one more time.
- 3) Continue checking blower speed and fan symbol until all speeds are checked.
- 4) Leave blower on MAX speed.

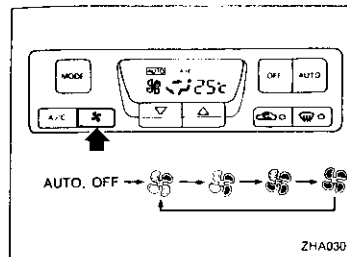

2. Check discharge air.

- 1) Press mode switch four times and DEF switch one time. When DEF switch is ON, DEF indicator should illuminate.

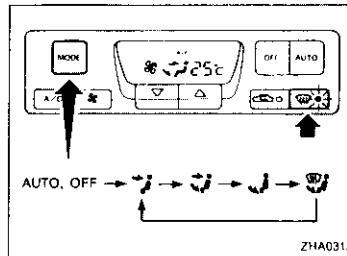

- 2) Confirm that discharge air comes out according to the air distribution table at left. Refer to "Discharge Air Flow", "DESCRIPTION" (HA-12).

NOTE:

Confirm that the compressor clutch is engaged (visual inspection) and intake door position is at FRESH when the DEF switch is pressed. Intake door position is checked in the next step.

Discharge air flow

Switch mode/indicator	Air outlet/distribution		
	Face	Foot	Defroster
	100%	—	—
	60%	40%	—
	—	80%	20%
	—	60%	40%
	—	—	100%

## Operational Check (Cont'd)

## 3. Check recirc

- 1) Press REC  switch. Recirc indicator should illuminate.
- 2) Listen for intake door position change (you should hear blower sound change slightly).

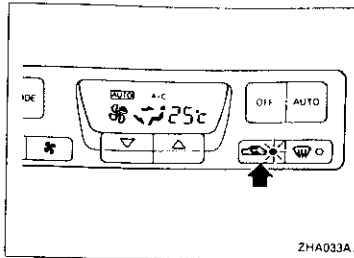

## 4. Check temperature decrease

- 1) Press the temperature switch (COLD) until 18°C is displayed.
- 2) Check for cold air at discharge air outlets.

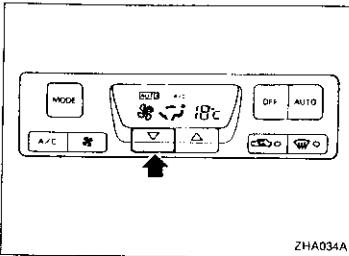

## 5. Check temperature increase

- 1) Press the temperature switch (HOT) until 32°C is displayed.
- 2) Check for hot air at discharge air outlets.

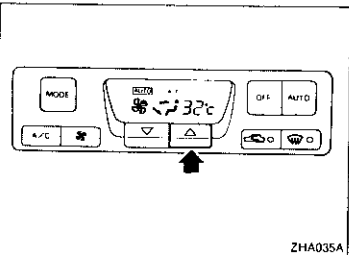

## 6. Check AUTO mode

- 1) Press AUTO switch.
- 2) Display should indicate AUTO and A/C. Confirm that the compressor clutch engages (audio or visual inspection). (Discharge air will depend on ambient, in-vehicle, and set temperatures).

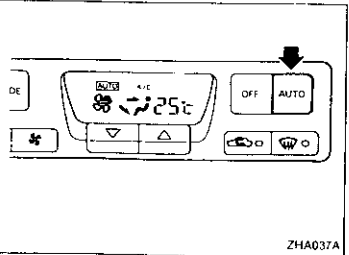

## 7. Check A/C mode

- 1) Press A/C switch.
- 2) Display should indicate AUTO (A/C goes out). Confirm that the compressor clutch is not engaged (visual inspection). (Discharge air will depend on ambient, in-vehicle, and set temperatures).
- 3) Repress A/C switch. Display should indicate A/C and the compressor clutch is engaged.

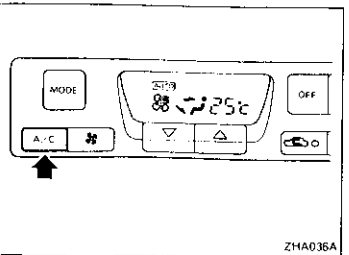

## Operational Check (Cont'd)

## 8. Check memory function

- 1) Press OFF switch
- 2) Turn the ignition off.
- 3) Turn the ignition on.
- 4) Press the AUTO switch.
- 5) Confirm that the set temperature remains at previous temperature.

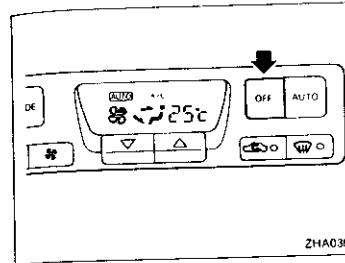



## Self-diagnosis

The self-diagnostic system diagnoses sensors, door motors, blower motor, etc. by system line. Refer to applicable sections (items) for details. Shifting from normal control to the self-diagnostic system is done as follows. Start the engine (turn the ignition switch from "OFF" to "ON"). And press "OFF" switch for at least 5 seconds. The "OFF" switch must be pressed within 5 seconds after starting the engine (ignition switch is turned "ON"). This system will be canceled by either pressing "OFF" switch or turning the ignition switch "OFF". Shifting from one step to another is accomplished by means of pushing ▲ (HOT) or ▼ (COLD) switch, as required. Additionally shifting from STEP 5 to AUXILIARY MECHANISM is accomplished by means of pushing Ⓢ (fan) switch.

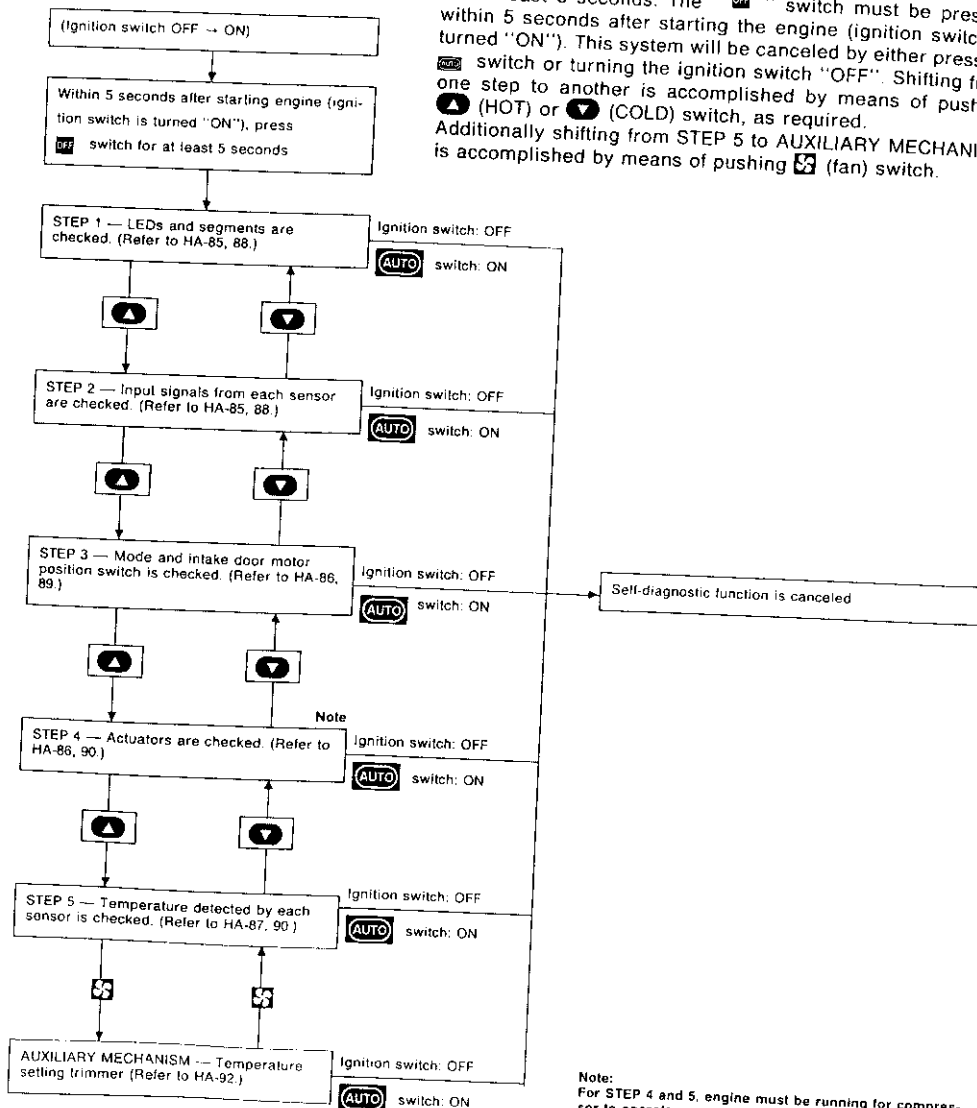

## Self-diagnosis (Cont'd)

## CHECKING PROCEDURE

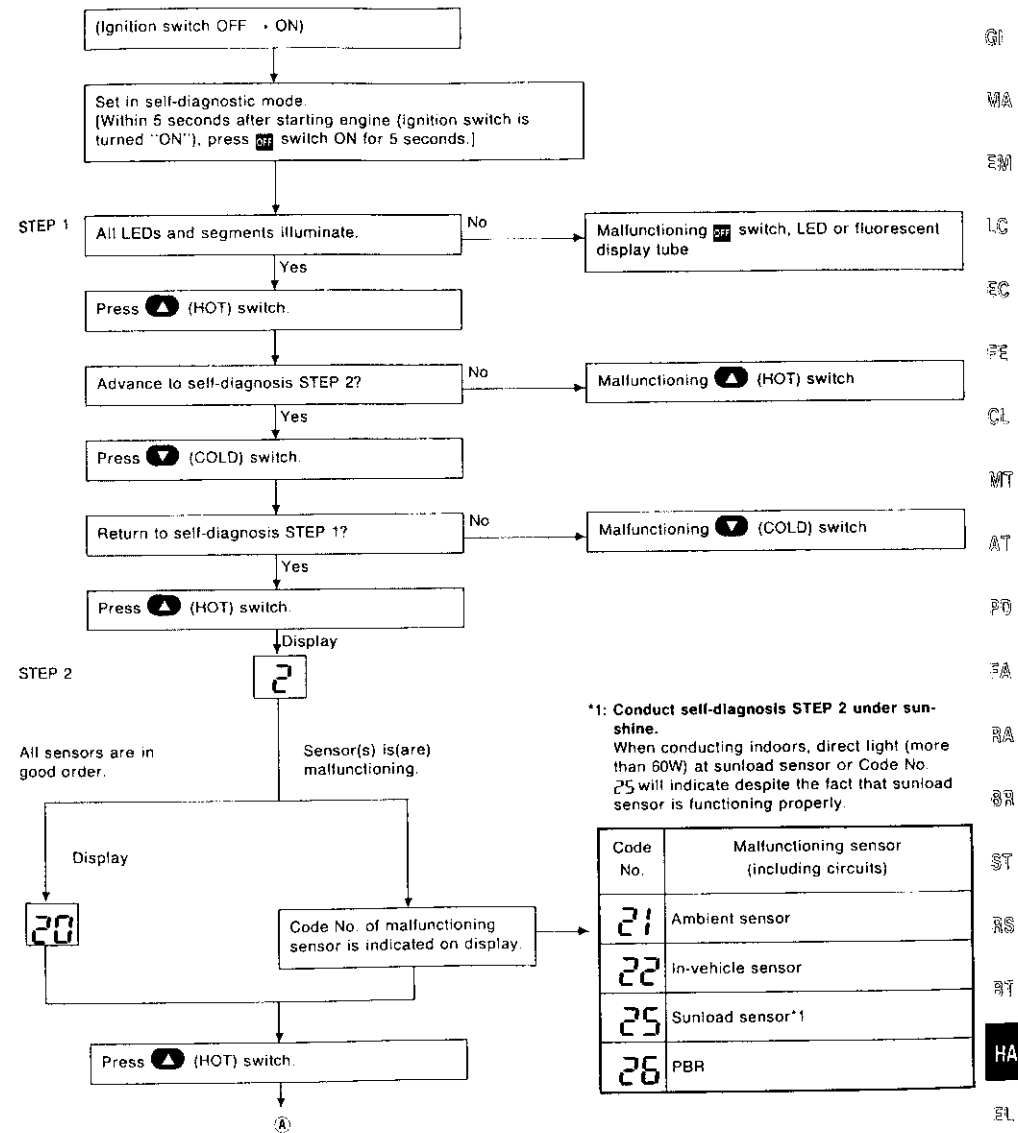

Note:  
At any time, you can return to a previous step in the self-diagnosis by pressing the ▼ (COLD) switch.

## TROUBLE DIAGNOSES

AUTO

### Self-diagnosis (Cont'd)

STEP 3

④  
3 Display

All mode and intake door motor position switches are in good order.

Mode door and intake motor position switch(es) is(are) malfunctioning.

30 Display

Code No. of malfunctioning mode door motor position switch is indicated on display.

Press  (HOT) switch.

STEP 4

41 Display

Code No. of actuators test pattern is indicated on display.

Press  (DEF) switch.

Press  (HOT) switch.

⑤

Code No	Malfunctioning part or circuit	
	Position switch	
31	VENT	Mode door motor
32	B/L	
33	FOOT	
34	FOOT/DEF	
35	DEF	Intake door motor
36	FRE	
38	20% FRE	
39	REC	

Code No.	Actuators test pattern					
	Mode door	Intake door	Air mix door	Bi-level door	Blower motor	Compressor
41	VENT	REC	Full Cold	OPEN	4 - 5V	ON
42	B/L	REC	Full Cold	OPEN	9 - 11V	ON
43	B/L	20% FRE	Full Hot	CLOSE	7 - 9V	ON
44	FOOT	FRE	Full Hot	CLOSE	7 - 9V	OFF
45	F/D	FRE	Full Hot	CLOSE	7 - 9V	OFF
46	DEF	FRE	Full Hot	CLOSE	10 - 12V	ON

Note:

For STEP 4, engine must be running for compressor to operate.

## TROUBLE DIAGNOSES

AUTO

### Self-diagnosis (Cont'd)

STEP 5

⑥  
5 Display

Press (DEF) switch. 

Temperature detected by each sensor is indicated on display.

Ambient sensor in-vehicle sensor

Press FAN switch. 

61 Display

AUXILIARY MECHANISM — Temperature setting trimmer

Turn ignition switch OFF or  (AUTO) switch ON.

END



## TRUBLE DIAGNOSES

AUTO

### Self-diagnosis (Cont'd)

#### HOW TO INTERPRET THE RESULTS

##### STEP 1: Checks LEDs and segments

When switch's LED and segments are in functioning properly STEP 1, LED and display will come on.

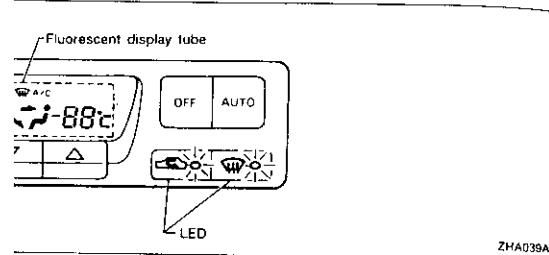

If LEDs or segments malfunction, LED will not come on or display will show incomplete segment.

##### STEP 2: Checks each sensor circuit for open or short circuit

Display shows "2" in STEP 2 mode. When all sensors are in good order, display shows "26". It takes approximately 5 seconds to check all sensors.

If a sensor is malfunctioning, the corresponding code No. is shown on display. A short circuit is identified by a blinking "2" preceding mode number.

HA-88

## TROUBLE DIAGNOSES

AUTO

### Self-diagnosis (Cont'd)

If two or more sensors malfunction, corresponding code Nos. respectively blink two times.

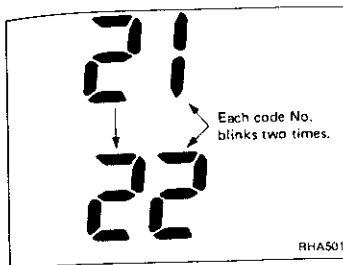

#### Sensors and abnormalities

If a circuit is opened or shorted, display shows its code No. when input corresponds with any of following conditions.

Code No.	Sensor	Open circuit	Short circuit
21	Ambient sensor	Less than -41.9°C (-43°F)	Greater than 100°C (212°F)
22	In-vehicle sensor	Less than -41.9°C (-43°F)	Greater than 100°C (212°F)
25	Sunload sensor*2	Less than 4.5 mA	Greater than 192 mA
26	PBR*1	Greater than 50%	Less than 30%

\*1: "50%" and "30%" refer to percentage with respect to full stroke of air mix door. (Full cold: 10%, Full hot: 90%)

\*2: Conduct self-diagnosis STEP 2 under sunshine. When conducting indoors, direct light (more than 60W) at sunload sensor.

##### STEP 3: Checks mode and intake door positions

Display shows "3" in STEP 3 mode. When all doors are in good order, display will then show "30". It takes approximately 20 seconds to check all mode and intake doors.

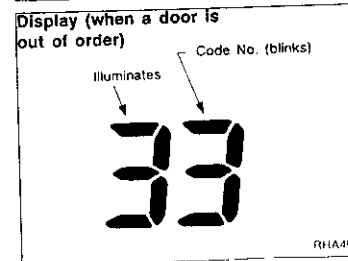
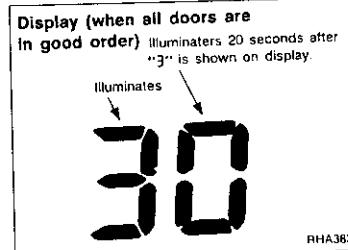

When abnormalities are detected, display shows a code No. corresponding with malfunctioning part.

Code No.	31	32	33	34	35	36	38	39
Malfunctioning part	VENT	B/L	FOOT	FOOT/DEF	DEF	FRE	20% FRE	REC

HA-89

## Self-diagnosis (Cont'd)

If two or more mode or intake doors are out of order, corresponding code numbers respectively blink two times.  
If mode door motor harness connector is disconnected, the following display pattern will appear.

31 → 32 → 33 → 34 → 35

If intake mode door harness connector is disconnected, the following display pattern will appear.

36 → 38 → 39

If any mode door motor position switch is malfunctioning, mode door motor will also malfunction.

## STEP 4: Checks operation of each actuator

Display shows "41" in STEP 4 mode.

When DEF switch is pressed one time, display shows "42". Thereafter, each time the switch is pressed, display advances one number at a time, up to "46", then returns to "41".

During inspection in STEP 4, the auto amp. will forcefully transmit an output to the affected actuators. The corresponding code Nos. are shown on display as indicated in the table below.

Checks must be made visually, by listening to any noise, or by touching air outlets with your hand, etc. for improper operation.

Code No.	Actuator					
	41	42	43	44	45	46
Mode door	VENT	B/L	B/L	FOOT	F/D	DEF
Intake door	REC	REC	20% FRE	FRE	FRE	FRE
Air mix door	Full Cold	Full Cold	Full Hot	Full Hot	Full Hot	Full Hot
Blower motor	4 - 5 V	9 - 11 V	7 - 9 V	7 - 9 V	7 - 9 V	10 - 12 V
Compressor	ON	ON	ON	OFF	OFF	ON
Bi-level door	Open	Open	Shut	Shut	Shut	Shut

Operating condition of each actuator cannot be checked by indicators.

## STEP 5: Checks temperature detected by sensors

## Checks temperature detected by sensors

Display shows "5" in STEP 5 mode.

- When DEF switch is pressed one time, display shows temperature detected by ambient sensor.
- When DEF switch is pressed second time, display shows temperature detected by in-vehicle sensor.
- When DEF switch is pressed third time, display returns to original presentation "5".

## Self-diagnosis (Cont'd)

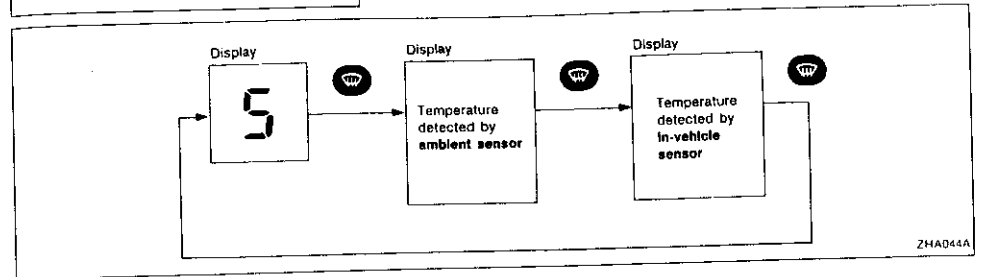
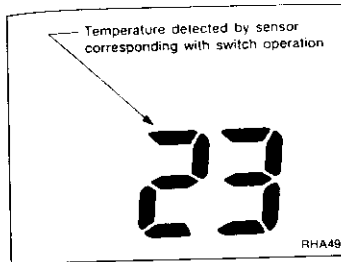

If temperature shown on display greatly differs from actual temperature, check sensor circuit at first. Then inspect sensor itself according to the procedures described in **Control System Input Component**. Refer to HA-128.

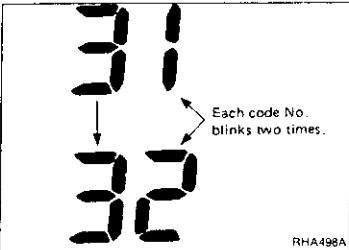

RHA498A

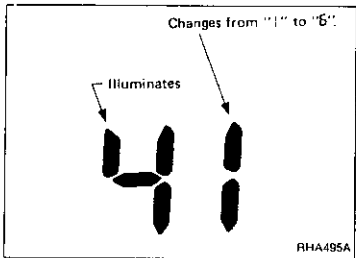

RHA495A

## Discharge air flow

Switch mode/ indicator	Air outlet/distribution		
	Face	Foot	Defroster
	100%	—	—
	60%	40%	—
	—	80%	20%
	—	60%	40%
	—	—	100%

RHA429EA

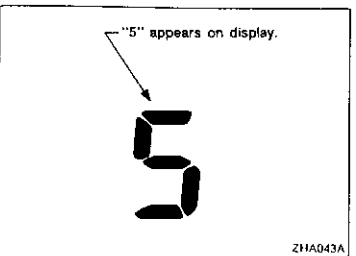



ZHA043A

## Self-diagnosis (Cont'd)

## AUXILIARY MECHANISM: Temperature setting trimmer

This trimmer compensates for differences between temperature setting (displayed digitally) and temperature felt by driver in a range of  $\pm 3^{\circ}\text{C}$ .

Operating procedures for this trimmer are as follows:

Starting with STEP 5 under "Self-diagnostic mode", press  (fan) switch to set air conditioning system in auxiliary mode. Then, press either  (HOT) or  (COLD) switch as desired. Temperature will change at a rate of  $1^{\circ}\text{C}$  each time a switch is pressed.

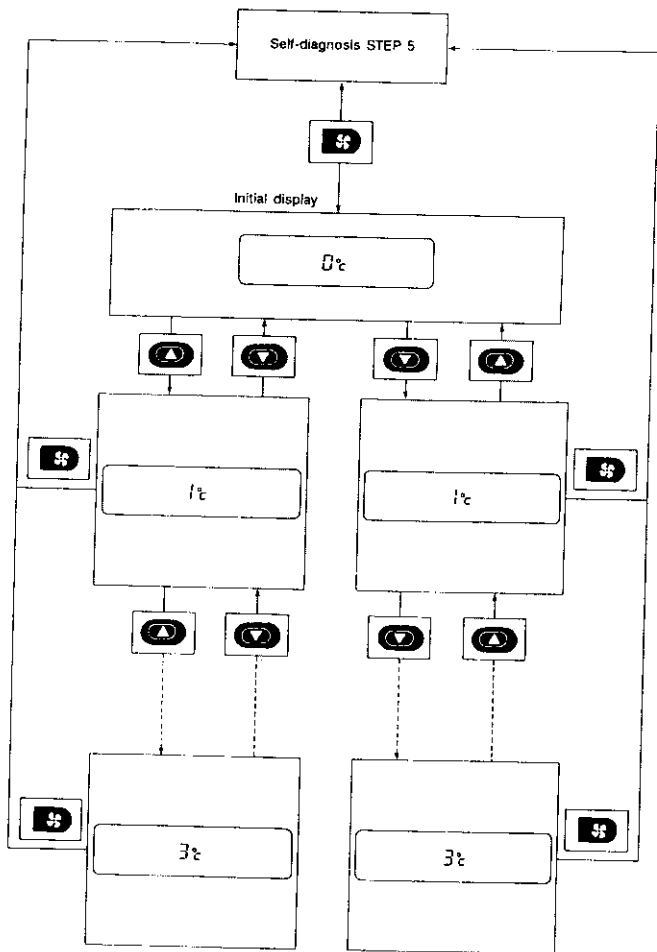

When battery cable is disconnected, trimmer operation is canceled and temperature set becomes that of initial condition, i.e.  $0^{\circ}\text{C}$ .

HA-92

## Preliminary Check

## PRELIMINARY CHECK 1

Air outlet does not change.

- Perform Self-diagnosis STEP 1 before referring to the flow chart.

CHECK SENSOR CIRCUIT.  
Set up Self-diagnosis STEP 2.  
Is each sensor circuit normal?  
Code No. 20 should be indicated on the display after approx. 5 seconds.

NG

CHECK SENSOR CIRCUIT IN DETAIL ACCORDING TO THE DIAGNOSTIC PROCEDURE BELOW CORRESPONDING TO EACH CODE NO.

Code No.	How to repair	Reference page
21	Go to Diagnostic Procedure 1.	HA-111
22	Go to Diagnostic Procedure 2.	HA-112
25	Go to Diagnostic Procedure 3.	HA-113
26	Go to Diagnostic Procedure 4.	HA-114
-21	Go to Diagnostic Procedure 1.	HA-111
-22	Go to Diagnostic Procedure 2.	HA-112
-25	Go to Diagnostic Procedure 3.	HA-113
-26	Go to Diagnostic Procedure 4.	HA-114

Are sensor circuits for ambient sensor and in-vehicle sensor operating normally? If malfunction is suspected, check temperature detected by each sensor using Self-diagnosis STEP 5. Confirm the temperature is within normal range before performing Diagnostic Procedures.

OK

CHECK MODE DOOR MOTOR.  
Set up Self-diagnosis STEP 3.  
Is mode door motor operating normally?  
Code No. 30 should be indicated on the display after approx. 20 seconds.

NG

Go to Diagnostic Procedure 5. (HA-115)

OK

CHECK MODE DOOR OPERATION.  
Set up Self-diagnosis STEP 4.  
Does air outlet change according to each code No.?

NG

CHECK SIDE LINK MECHANISM.  
Refer to CONTROL LINKAGE ADJUSTMENT. (HA-125)

NG

Repair.

41	42	43	44	45	46
VENT	B/L	B/L	FOOT	F/D	DEF

Refer to Discharge Air Flow. (HA-12)

OK

Go to Diagnostic Procedure 5. (HA-115)

OK

Air outlet control system is normal. Refer to Mode door control specification. (HA-133)

HA-93

## Preliminary Check (Cont'd)

## PRELIMINARY CHECK 2

Intake door does not change.

- Perform Self-diagnosis STEP 1 before referring to the following flow chart.

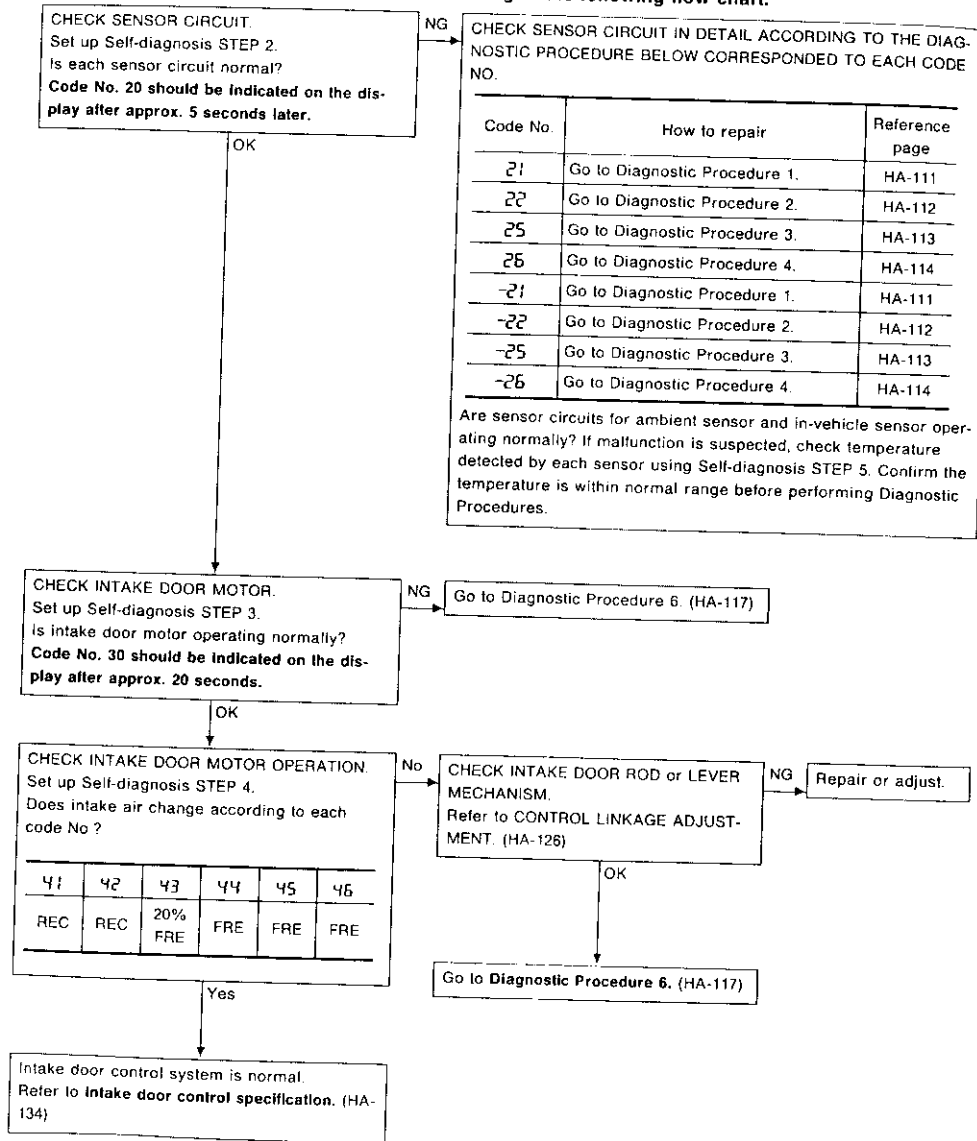

## Preliminary Check (Cont'd)

## PRELIMINARY CHECK 3

Insufficient cooling

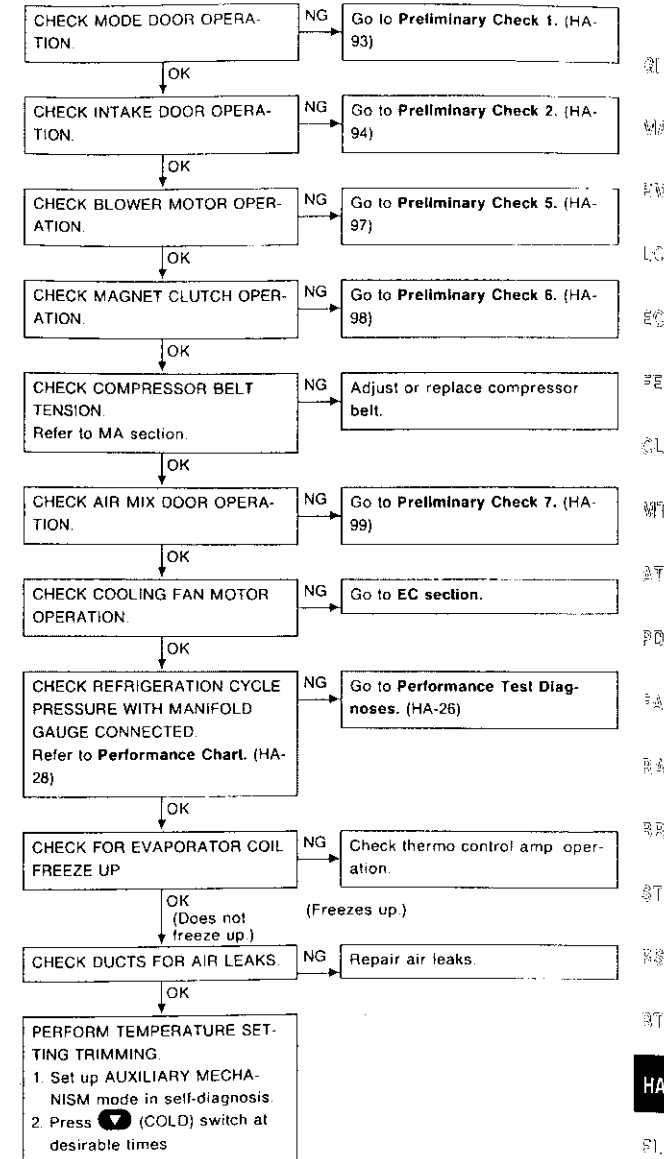

## TROUBLE DIAGNOSES

AUTO

### PRELIMINARY CHECK 4

Insufficient heating

#### Preliminary Check (Cont'd)

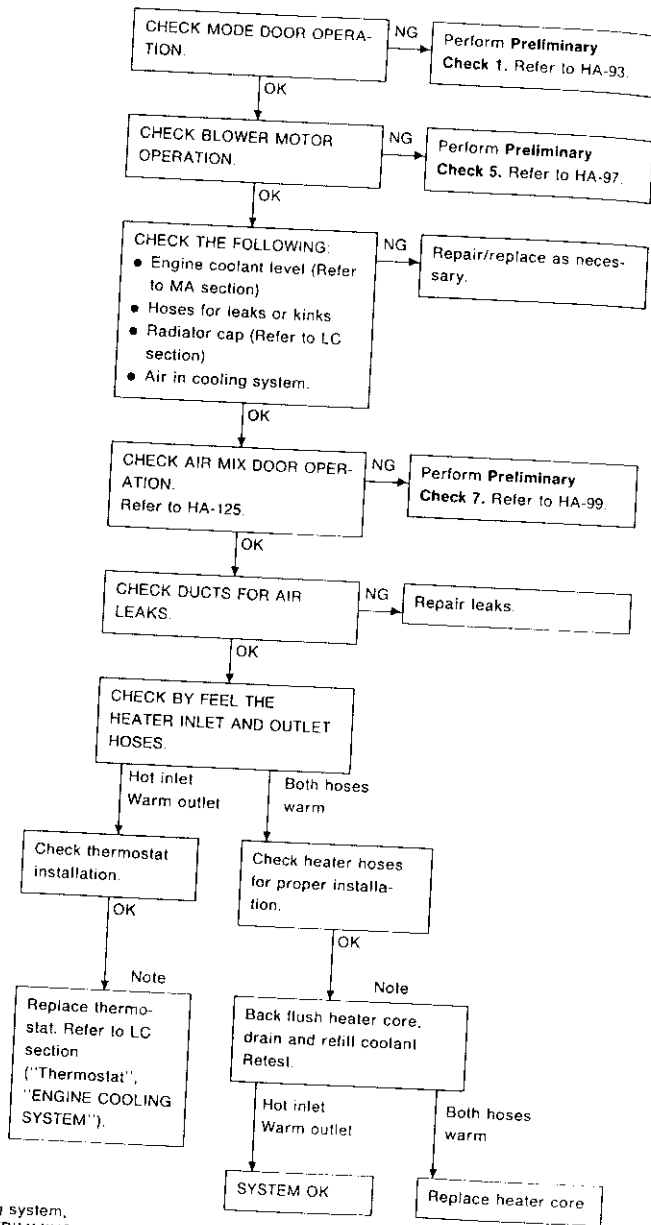

HA-96

Note: To avoid unnecessary service of heating system, first perform TEMPERATURE SETTING TRIMMING. Refer to "AUXILIARY MECHANISM", "Self-diagnosis"

## TROUBLE DIAGNOSES

AUTO

### PRELIMINARY CHECK 5

Blower motor operation is malfunctioning.

- Perform Self-diagnosis STEP 1 before referring to the following flow chart.

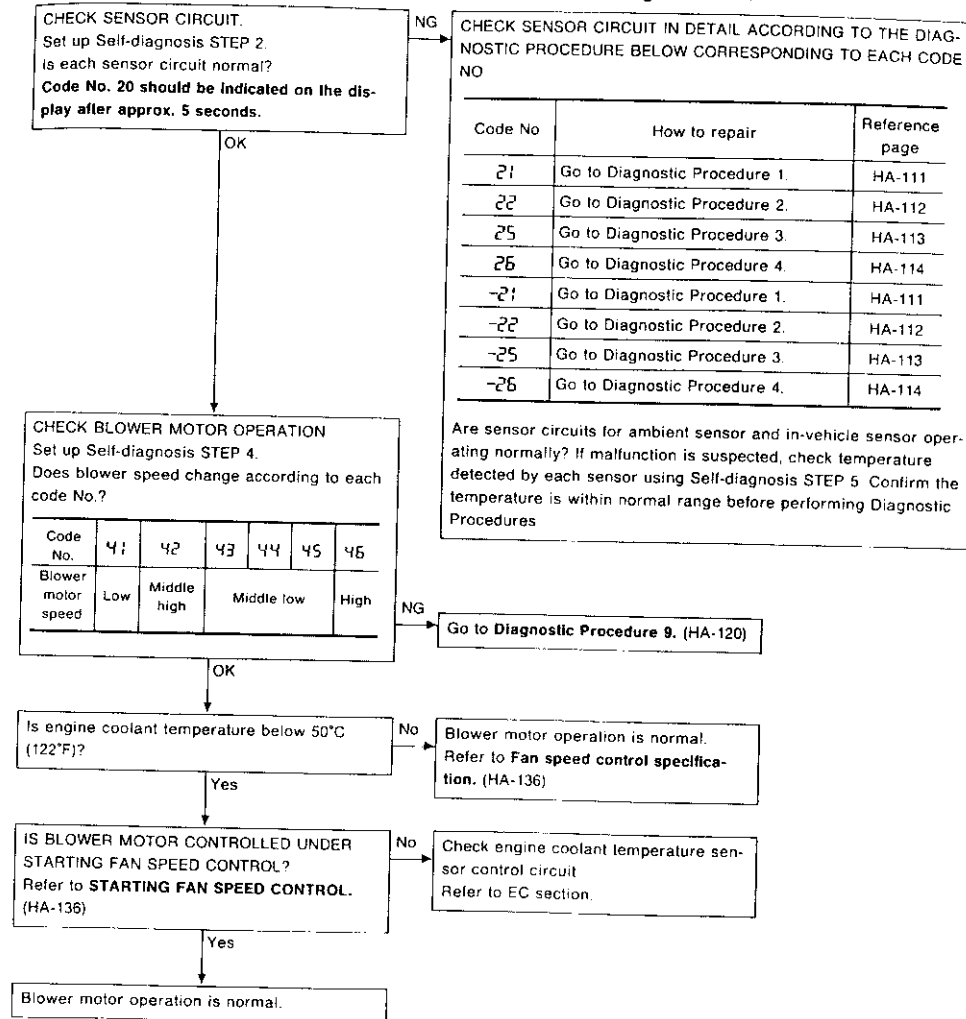

Code No	How to repair	Reference page
21	Go to Diagnostic Procedure 1.	HA-111
22	Go to Diagnostic Procedure 2.	HA-112
25	Go to Diagnostic Procedure 3.	HA-113
26	Go to Diagnostic Procedure 4.	HA-114
-21	Go to Diagnostic Procedure 1.	HA-111
-22	Go to Diagnostic Procedure 2.	HA-112
-25	Go to Diagnostic Procedure 3.	HA-113
-26	Go to Diagnostic Procedure 4.	HA-114

Are sensor circuits for ambient sensor and in-vehicle sensor operating normally? If malfunction is suspected, check temperature detected by each sensor using Self-diagnosis STEP 5. Confirm the temperature is within normal range before performing Diagnostic Procedures

Code No.	41	42	43	44	45	46
Blower motor speed	Low	Middle high		Middle low		High

Go to Diagnostic Procedure 9. (HA-120)

Blower motor operation is normal. Refer to Fan speed control specification. (HA-136)

Check engine coolant temperature sensor control circuit. Refer to EC section.

Blower motor operation is normal.

HA-97

## Preliminary Check (Cont'd)

## PRELIMINARY CHECK 6

Magnet clutch does not engage.

Perform Self-diagnosis STEP 1 before referring to the following flow chart.

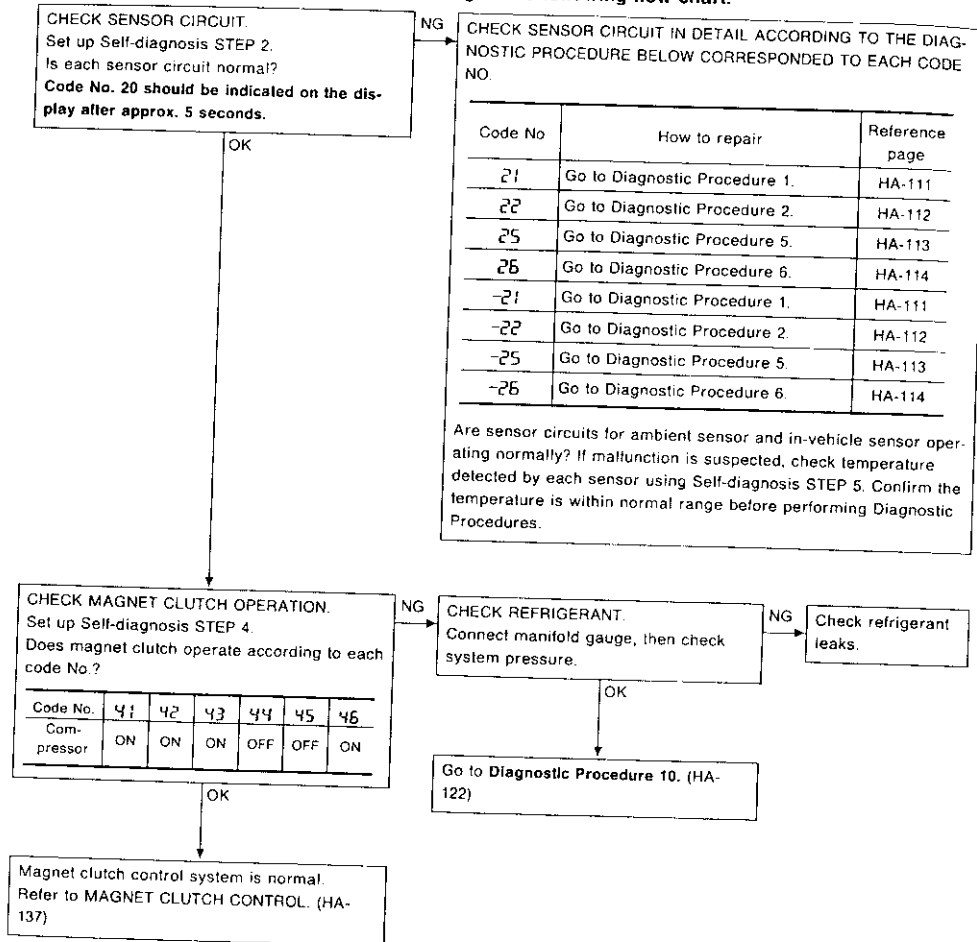

## Preliminary Check (Cont'd)

## PRELIMINARY CHECK 7

Discharged air temperature does not change.

Perform Self-diagnosis STEP 1 before referring to the following flow chart.

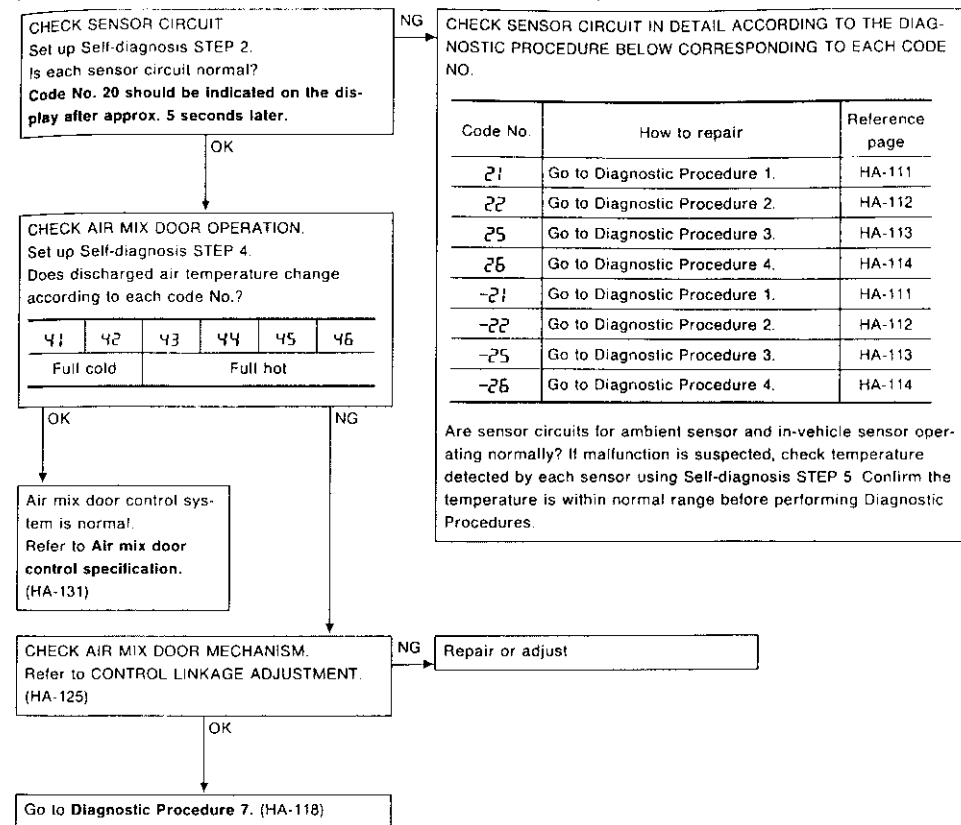

Preliminary Check (Cont'd)

PRELIMINARY CHECK 8

Noise

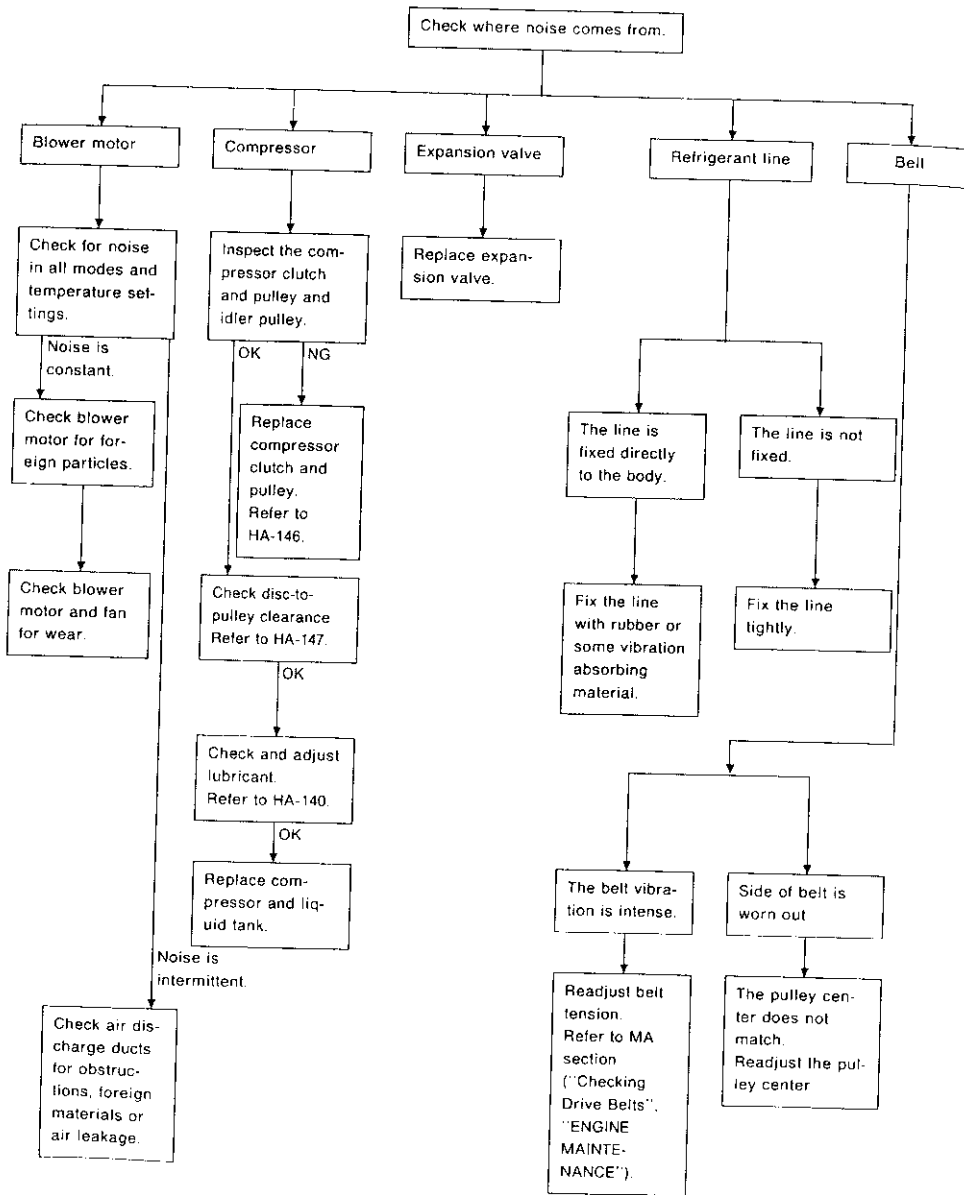

Harness Layout

Engine compartment

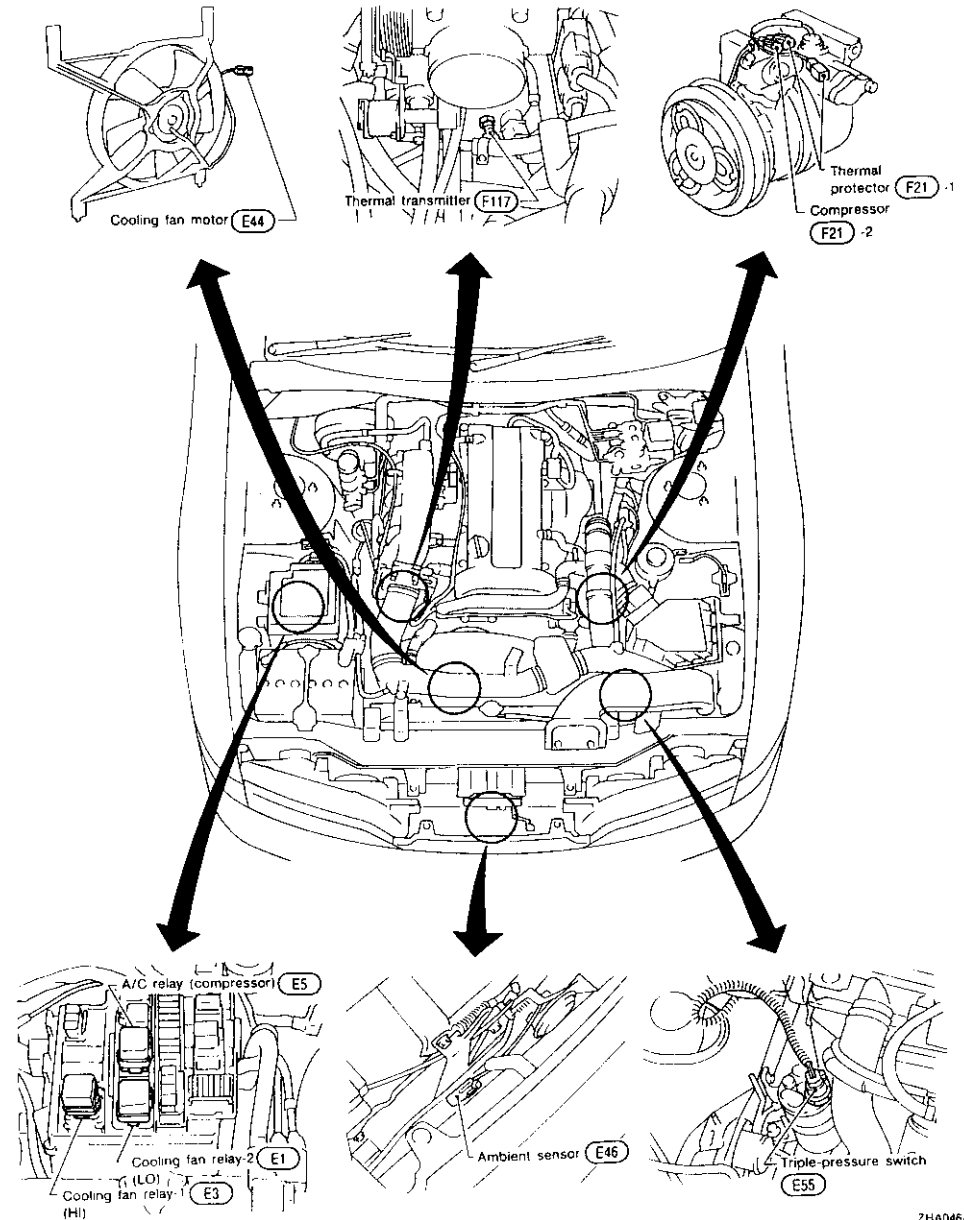

Harness Layout (Cont'd)

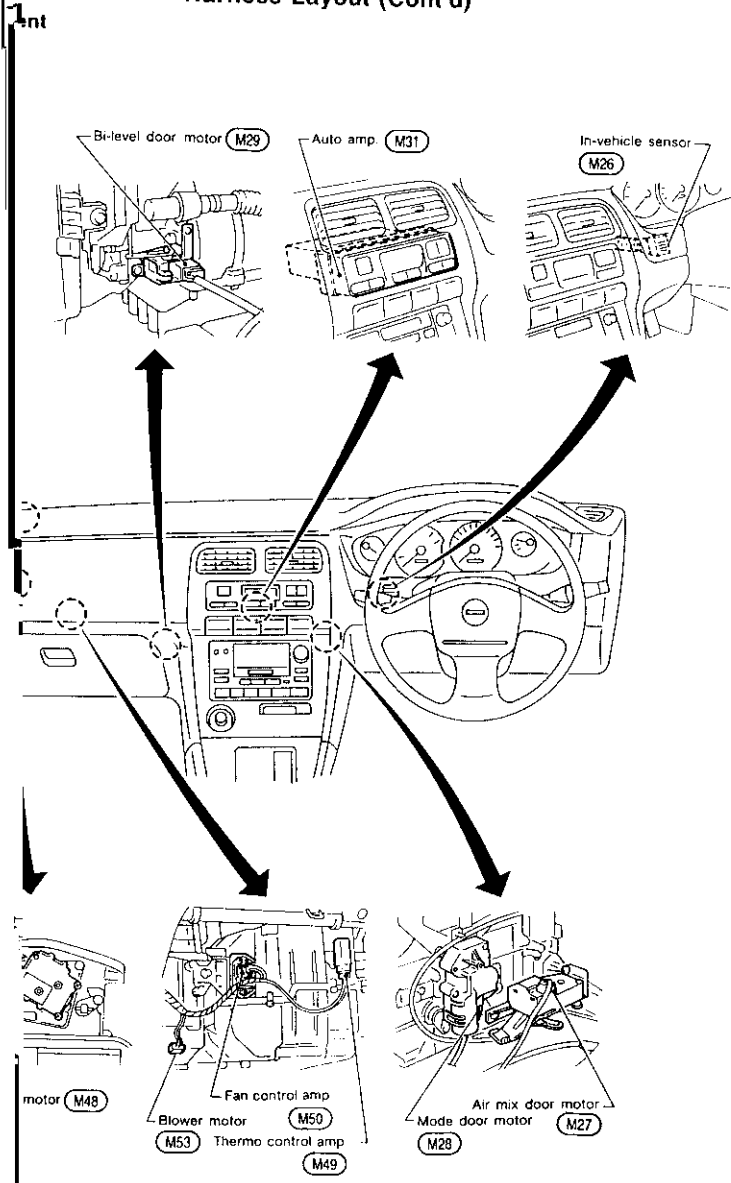

Circuit Diagram

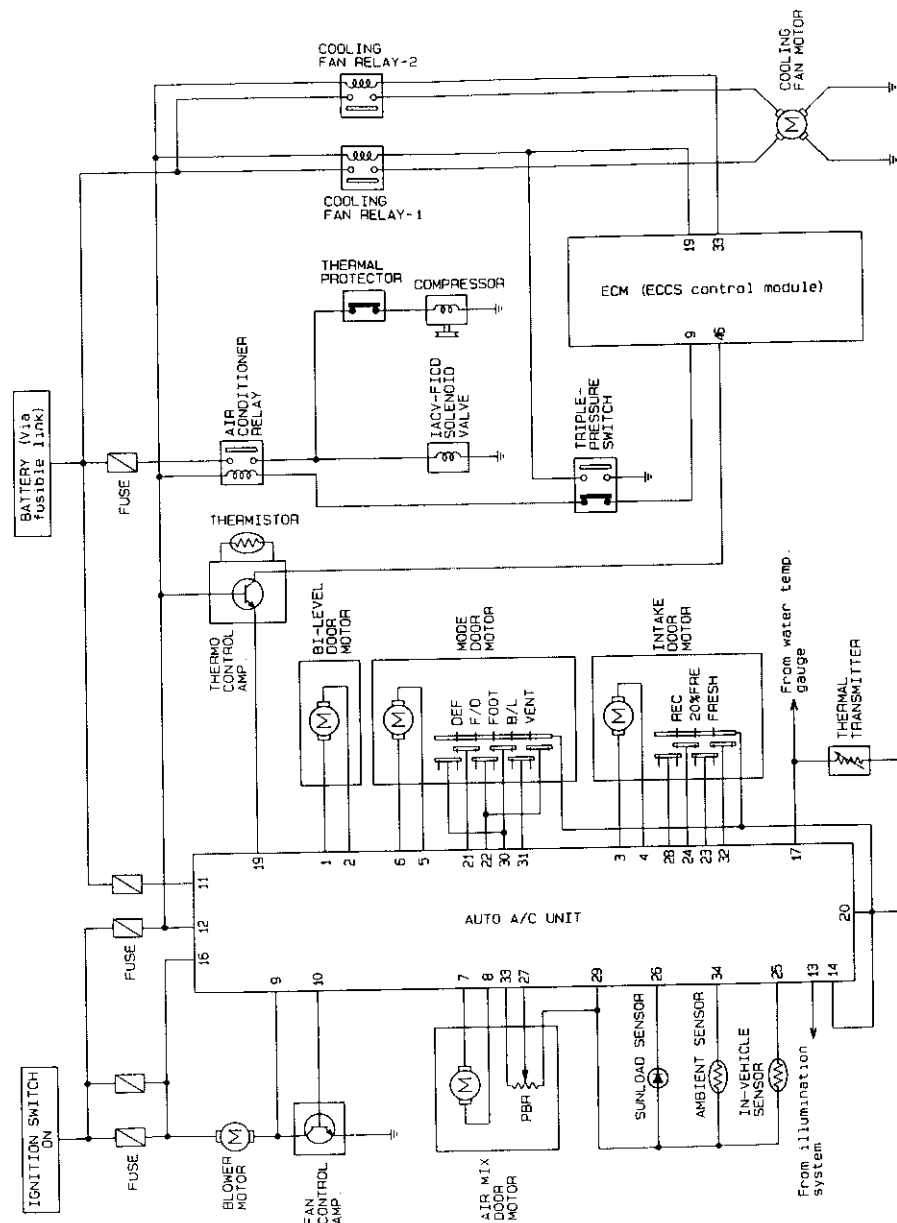



HA-A/C, A-02

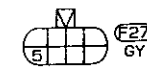
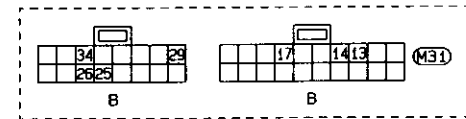
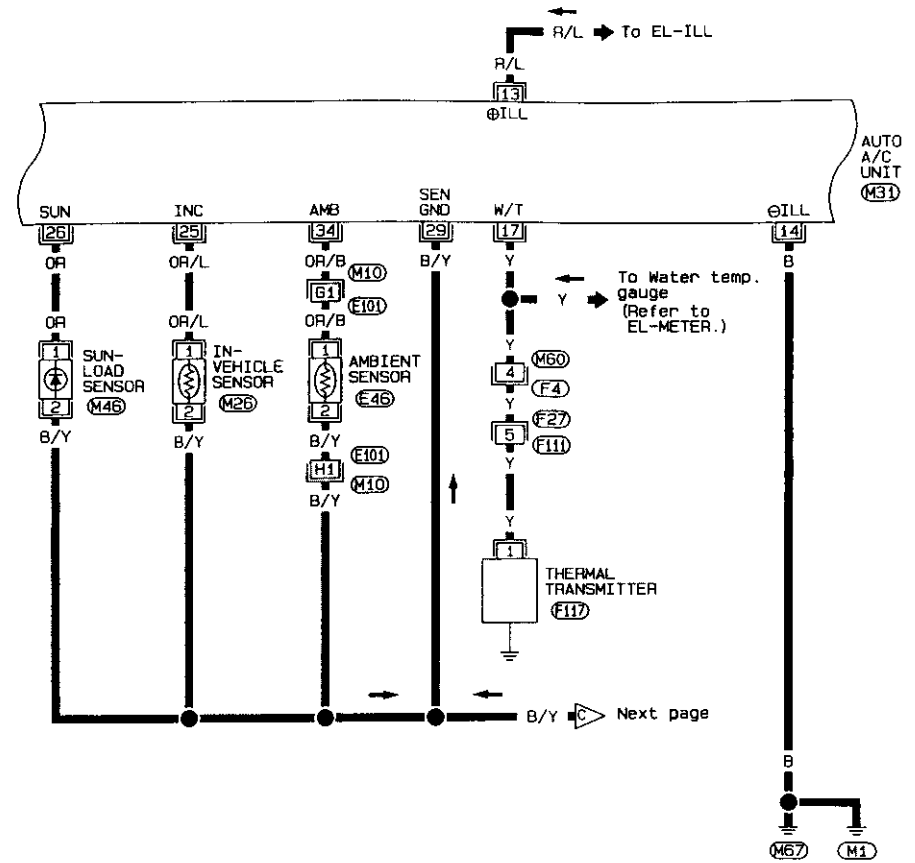

Refer to last page (Foldout page).

- M10, E101
- M60, F4



TROUBLE DIAGNOSES

Wiring Diagram — A/C, A — (Cont'd)

AUTO

HA-A/C, A-03

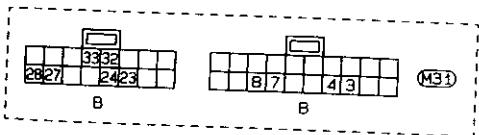
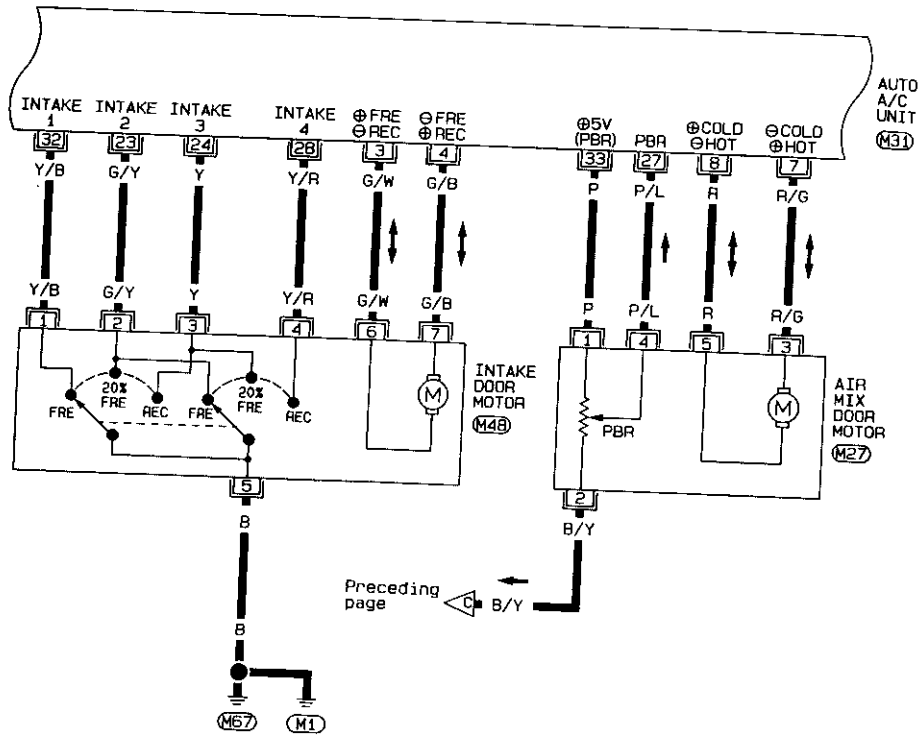

TROUBLE DIAGNOSES

Wiring Diagram — A/C, A — (Cont'd)

AUTO

HA-A/C, A-04

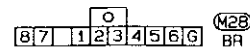
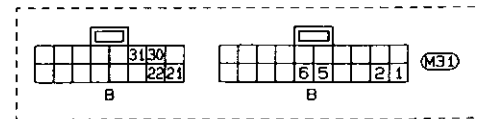
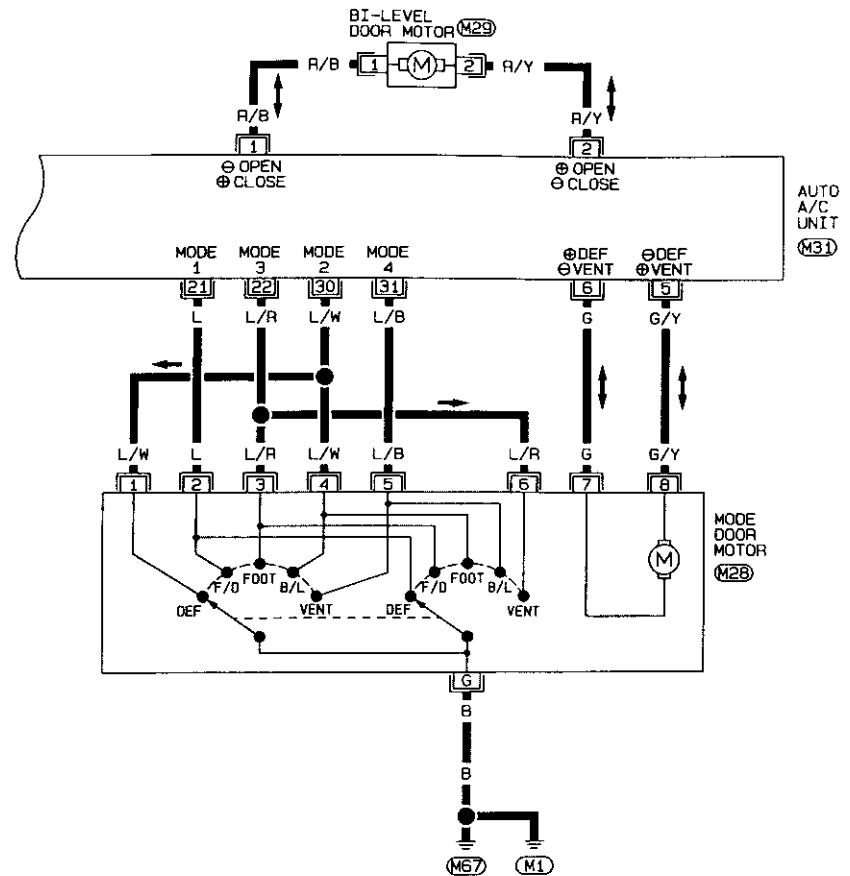

TROUBLE DIAGNOSES

AUTO

Wiring Diagram — A/C, A — (Cont'd)

HA-A/C, A-05

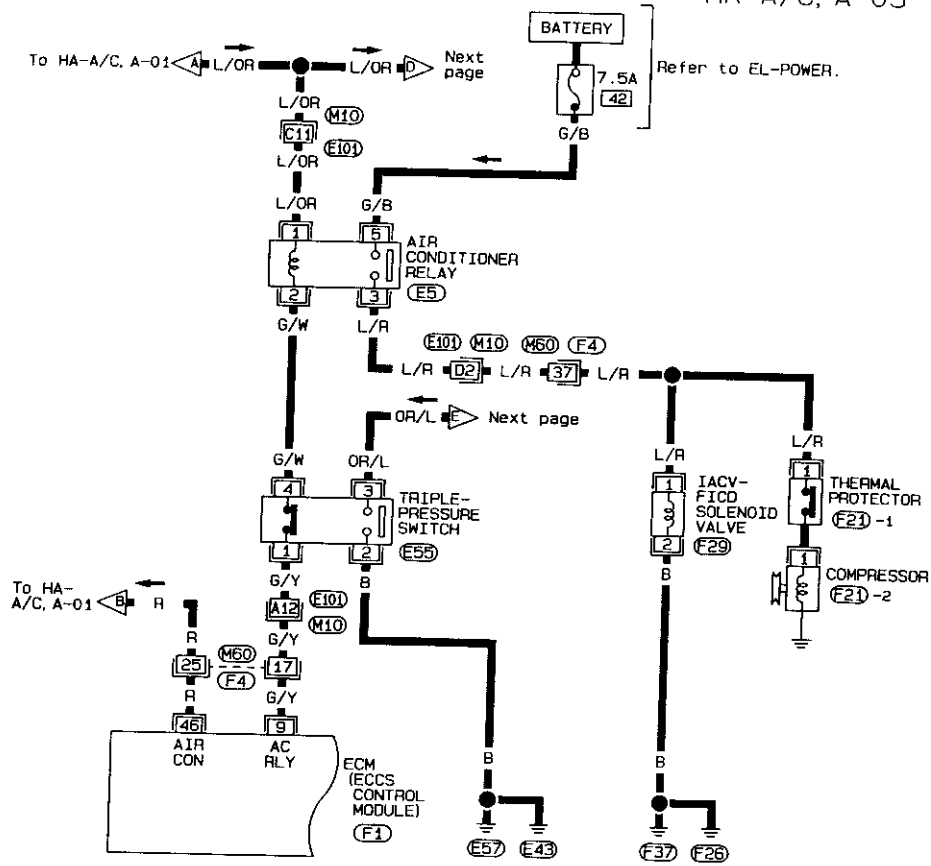

To HA-A/C, A-01

Next page

Refer to EL-POWER.

E57 E43

F37 F26

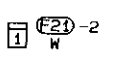
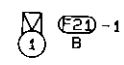
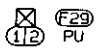
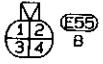
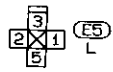

Refer to last page (Foldout page).

- M10, E101
- M60, F4
- F1

TROUBLE DIAGNOSES

AUTO

Wiring Diagram — A/C, A — (Cont'd)

HA-A/C, A-06

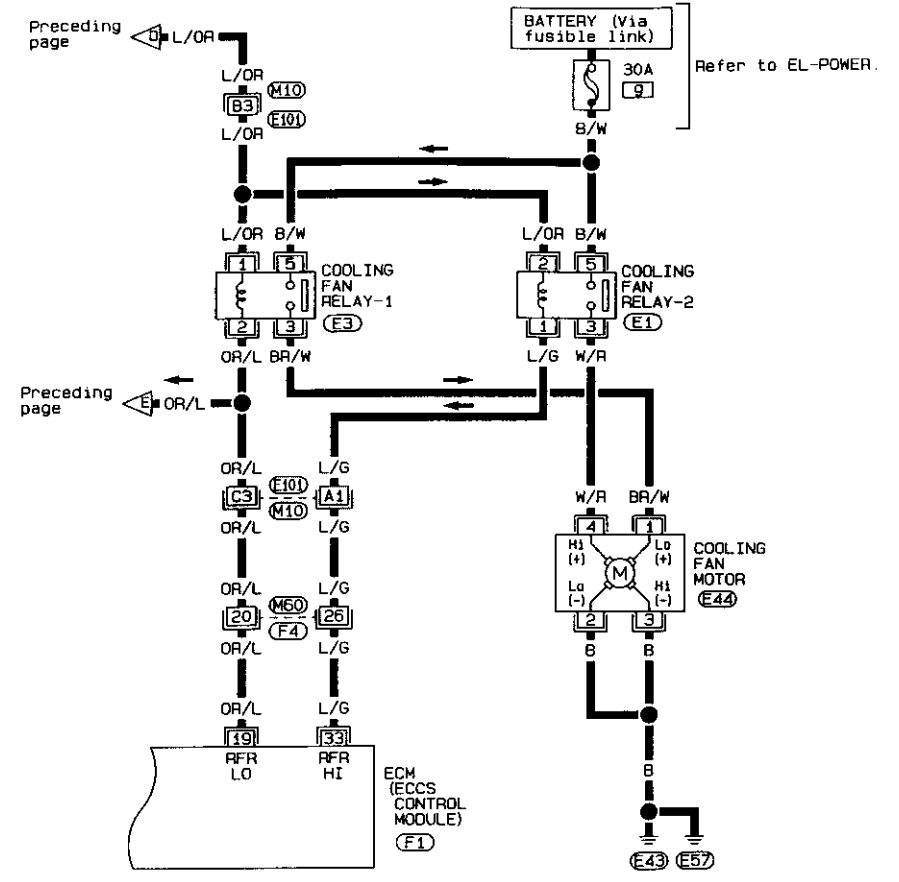

Preceding page

Refer to EL-POWER.

Preceding page

E43 E57

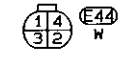
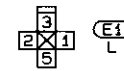

Refer to last page (Foldout page).

- M10, E101
- M60, F4
- F1

HA  
FL  
FX

### Main Power Supply and Ground Circuit Check POWER SUPPLY CIRCUIT CHECK FOR AUTO A/C SYSTEM

Check power supply circuit for auto air conditioning system. Refer to "POWER SUPPLY ROUTING" in EL section and Wiring Diagram.

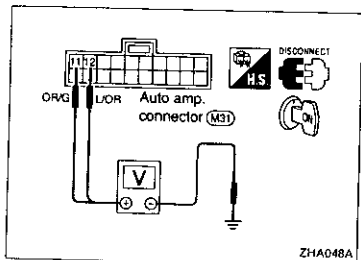

ZHA048A

#### AUTO AMP. CHECK

Check power supply circuit for auto amp. with ignition switch ON.

1. Disconnect auto amp. harness connector.
2. Connect voltmeter from harness side.
3. Measure voltage across terminal ①, ② and body ground.

Voltmeter terminal		Voltage
⊕	⊖	
①, ②	Body ground	Approx. 12V

Check body ground circuit for auto amp. with ignition switch OFF.

1. Disconnect push control unit harness connector.
2. Connect ohmmeter from harness side.
3. Check for continuity between terminal ② and body ground.

Ohmmeter terminal		Continuity
⊕	⊖	
②	Body ground	Yes

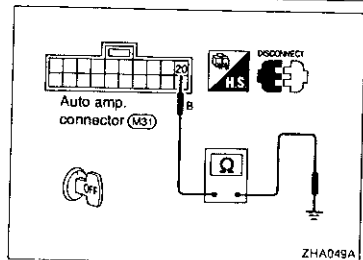

ZHA049A

### Diagnostic Procedure 1

**SYMPTOM:** Ambient sensor circuit is open or shorted. (21 or -21 is indicated on display as a result of conducting Self-diagnosis STEP 2.)

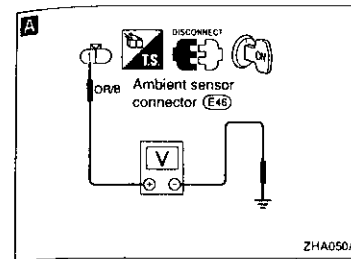

ZHA050A

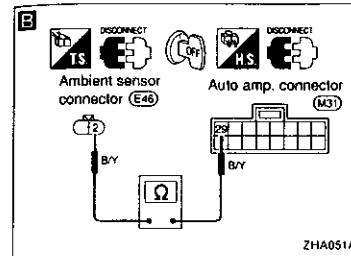

ZHA051A

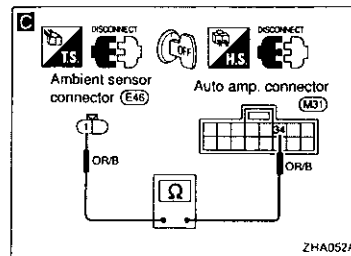

ZHA052A

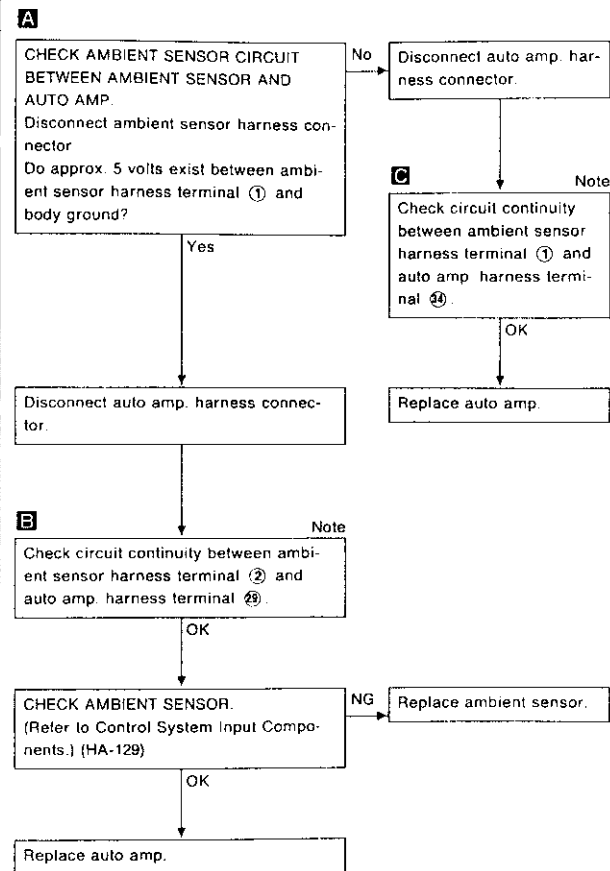

## Diagnostic Procedure 2

**SYMPTOM:** In-vehicle sensor circuit is open or shorted. (22 or -22 is indicated on display as a result of conducting Self-diagnosis STEP 2.)

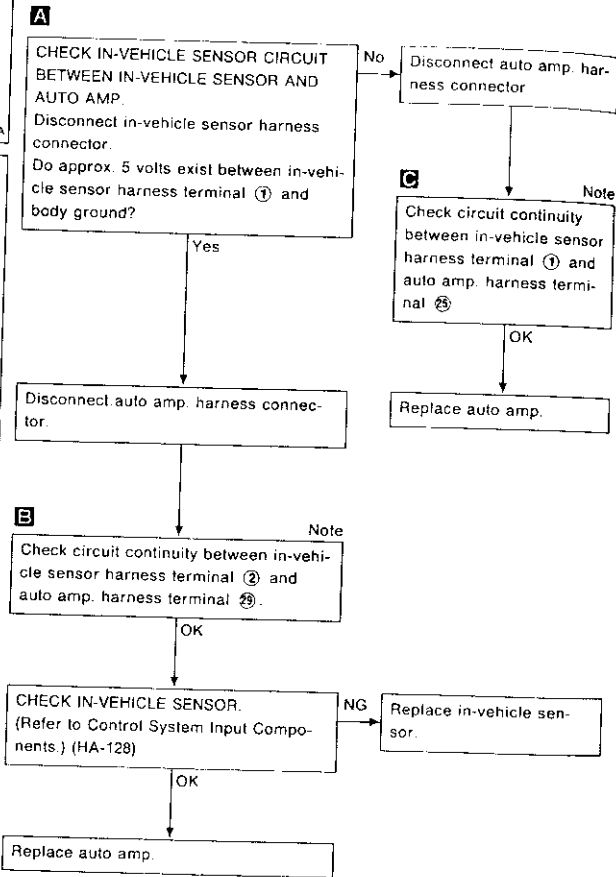
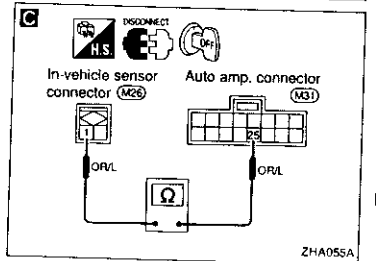
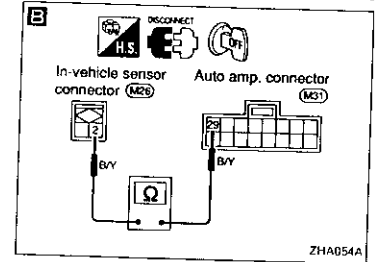
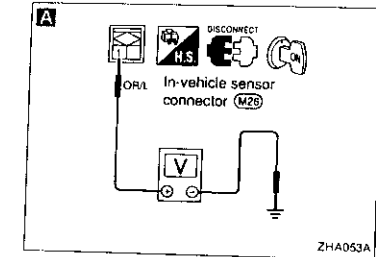

**Note:**  
If the result is NG after checking circuit continuity, repair harness or connector.

## Diagnostic Procedure 3

**SYMPTOM:** Sunload sensor circuit is open or shorted. (25 or -25 is indicated on display as a result of conducting Self-diagnosis STEP 2.)

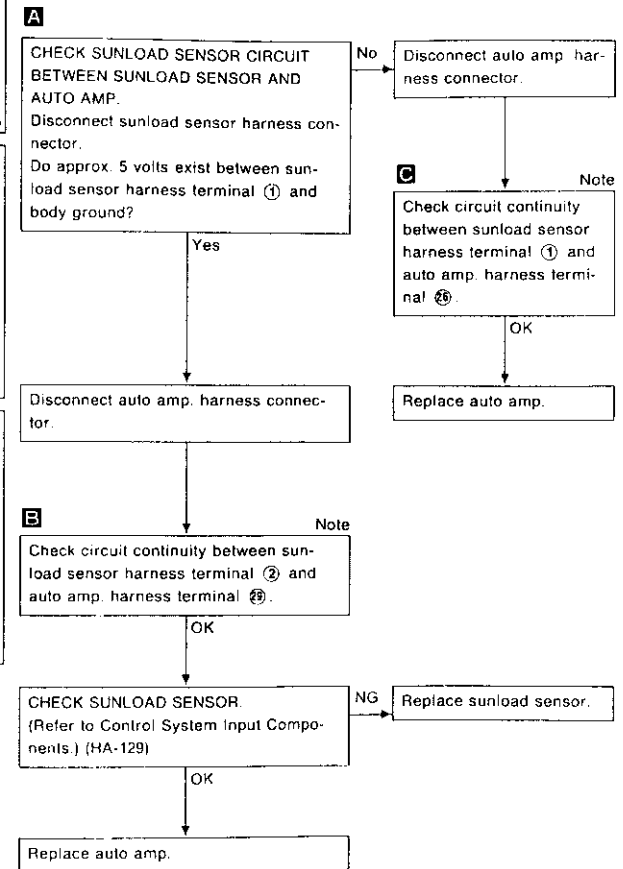
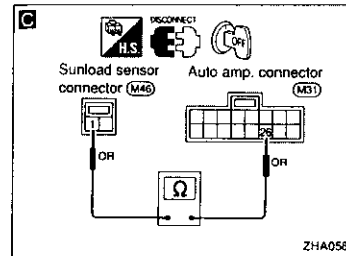
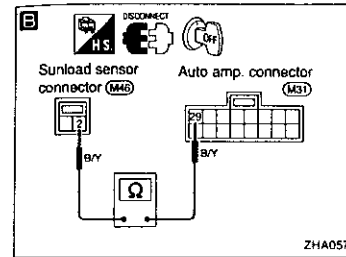
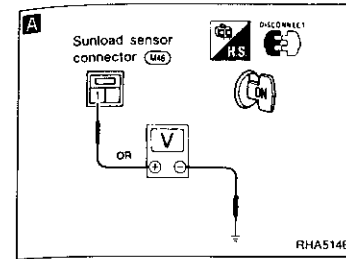

**Note:**  
If the result is NG after checking circuit continuity, repair harness or connector.

## Diagnostic Procedure 4

**SYMPTOM: PBR circuit is open or shorted. (25 or -25 is indicated on display as a result of conducting Self-diagnosis STEP 2.)**

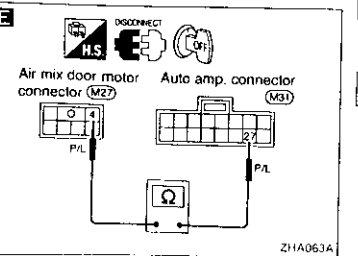
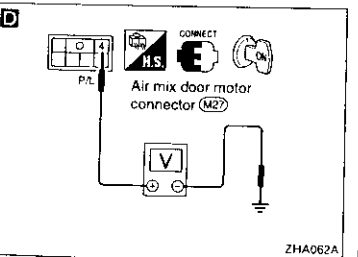
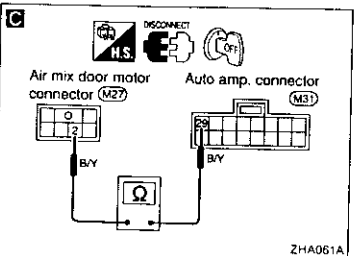
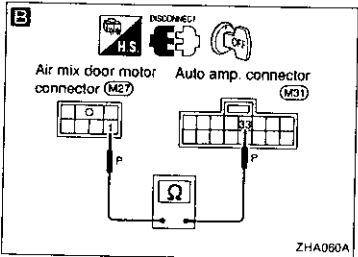
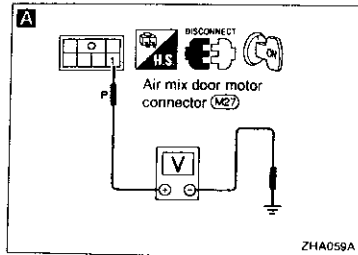

**A** CHECK PBR CIRCUIT BETWEEN PBR AND AUTO AMP.  
Disconnect air mix door motor harness connector.  
Do approx. 5 volts exist between air mix door motor harness terminal ① and body ground?

No → Disconnect auto amp harness connector.

**B** Check circuit continuity between air mix door motor harness terminal ① and auto amp harness terminal ③.

Replace auto amp.

**C** Check circuit continuity between air mix door motor harness terminal ② and auto amp harness terminal ②.

**D** CHECK PBR CIRCUIT BETWEEN PBR AND AUTO AMP.  
1. Reconnect auto amp harness connector and air mix door harness connector.  
2. Set temperature switch to full hot 32°C (90°F) with ignition switch ON.  
3. Do approx. 4.5 volts exist between air mix door motor harness terminal ④ and body ground?

Yes → Disconnect auto amp harness connector and air mix door harness connector.

**E** Check circuit continuity between air mix door motor harness terminal ④ and auto amp harness terminal ②.

Replace auto amp.

CHECK PBR. (Refer to Control System Output Components.) (HA-132)

NG → Replace air mix door motor (PBR).

Replace auto amp.

**Note:**  
If the result is NG after checking circuit continuity, repair harness or connector.

## Diagnostic Procedure 5

**SYMPTOM: Mode door motor does not operate normally.**  
• Perform Self-diagnosis STEPS 1 to 4 before referring to the following flow chart.

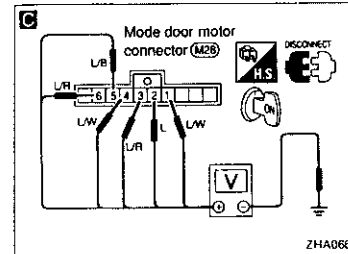
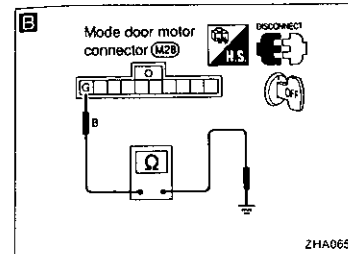
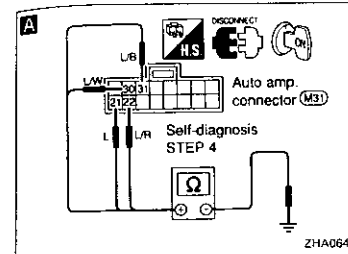

**A** CHECK MODE DOOR MOTOR POSITION SWITCH.  
1. Set up code No. 41 in Self-diagnosis STEP 4.

2. Disconnect auto amp harness connector after turning ignition switch OFF.

3. Check if continuity exists between terminal ② or ① of auto amp harness connector and body ground.

4. Using above procedure, check for continuity in any other mode, as indicated in chart.

Code No.	Condition	Terminal No.		Continuity
		⊕	⊖	
41	VENT	② or ①	⊖	Body ground Yes
42 or 43	B/L	② or ①	⊖	
44	FOOT	② or ①	⊖	
45	F/D	② or ①	⊖	
46	DEF	② or ①	⊖	

NG → Disconnect mode door motor harness connector.

**B** CHECK BODY GROUND CIRCUIT FOR MODE DOOR MOTOR.  
Does continuity exist between mode door motor harness terminal ② and body ground?

Reconnect auto amp harness connector.

**C** CHECK POWER SUPPLY FOR MODE DOOR MOTOR CONTROL CIRCUIT.  
Do approx. 5 volts exist between mode door motor harness terminals and body ground?

Terminal No.	Voltage	
	⊕	⊖
①	Body ground	Approx. 5V
②		
③		
④		
⑤		

Yes → Reconnect mode door motor harness connector.

NG → (Go to next page.)

**Note:**  
If the result is NG after checking circuit continuity, repair harness or connector.

Diagnostic Procedure 5 (Cont'd)

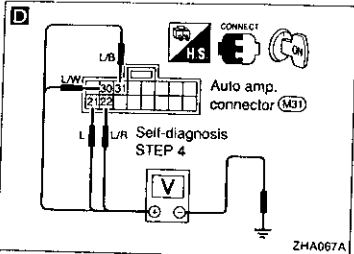

**D** CHECK MODE DOOR MOTOR POSITION SWITCH.  
Set up Self-diagnosis STEP 4.  
Measure voltage across auto amp. harness terminals and body ground.

Code No.	Condition	Terminal No.				Body ground
		(1)	(2)	(3)	(4)	
41	VENT	5V	0V	5V	0V	
42 or 43	B/L	5V	5V	0V	0V	
44	FOOT	5V	0V	0V	5V	
45	F/D	0V	0V	5V	5V	
46	DEF	0V	5V	0V	5V	

0V: Approx 0V  
5V: Approx 5V

**E** Check circuit continuity between each terminal on auto amp. and on mode door motor.

Terminal No.	Continuity	
	Auto amp.	Mode door motor
(1)	(2)	Yes
(2)	(3) or (5)	
(3)	(1) or (4)	
(4)	(5)	
(5)	(1)	

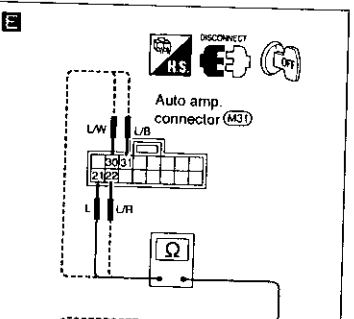

OK → Replace mode door motor.  
NG → Replace auto amp.

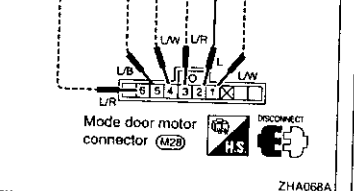

**F** CHECK FOR OUTPUT OF AUTO AMP.  
Do approx. 10.5 volts exist between auto amp. harness terminals (6) and (5) when code No. is switched from "41" to "42" or when code No. is switched from "45" to "41"?

Code No.	Mode door motor operation	Terminal No.		Voltage V
		(6)	(5)	
41 → 42	VENT → B/L	⊕	⊖	Approx 10.5
46 → 41	DEF → VENT	⊖	⊕	
-	Stop	-	-	0

Yes → Replace mode door motor.  
No → Replace auto amp.

**Note:**  
If the result is NG after checking circuit continuity, repair harness or connector.

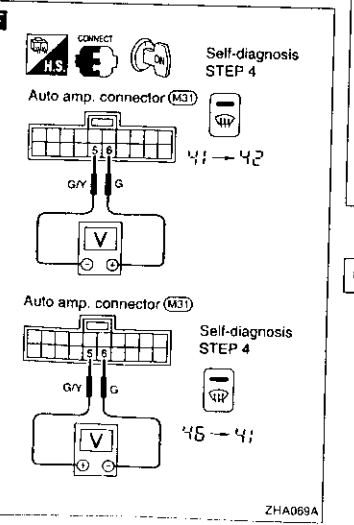

Diagnostic Procedure 6

**SYMPTOM:** Intake door motor does not operate normally.  
• Perform Self-diagnosis STEPS 1, 2 and 4 before referring to the flow chart.

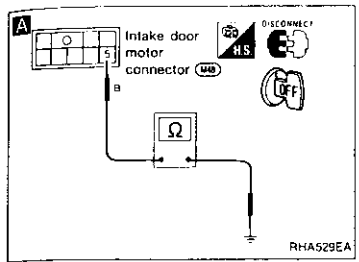

**A** CHECK BODY GROUND CIRCUIT FOR INTAKE DOOR MOTOR.  
Disconnect intake door motor harness connector.  
Does continuity exist between intake door motor harness terminal (5) and body ground?

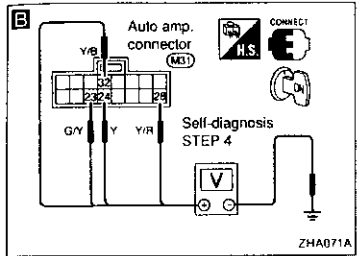

Yes → **B** CHECK FOR AUTO AMP. OUTPUT.  
Set up Self-diagnosis STEP 4.  
Measure voltage across auto amp. harness terminals and body ground.

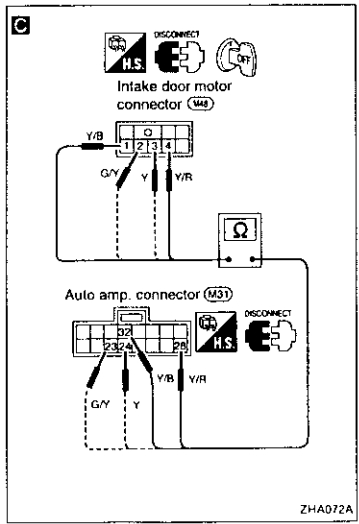

**B** CHECK FOR AUTO AMP. OUTPUT.  
Set up Self-diagnosis STEP 4.  
Measure voltage across auto amp. harness terminals and body ground.

Code No.	Terminal No.		Condition	Voltage V
	(1)	(2)		
41	(1) or (2)		REC	5
42	(1) or (2)		FRE	0
43	(3) or (4)	Body ground	20% FRE	5
44	(3) or (4)		FRE	0
45	(1) or (2)		FRE	5
46	(3) or (4)		FRE	0

0V: Approx 0V  
5V: Approx 5V

OK → Replace intake door motor.  
NG → **C** Check circuit continuity between each terminal on auto amp. and on intake door motor.

**C** Check circuit continuity between each terminal on auto amp. and on intake door motor.

Terminal No.	Continuity	
	Auto amp.	Intake door motor
(1)	(1)	Yes
(2)	(2)	
(3)	(3)	
(4)	(4)	
(5)	(5)	

OK → Replace auto amp.

**Note:**  
If the result is NG after checking circuit continuity, repair harness or connector.

**Diagnostic Procedure 7**

**SYMPTOM:** Air mix door motor does not operate normally.  
 • Perform Self-diagnosis STEPS 1, 2 and 4 before referring to the following flow chart.

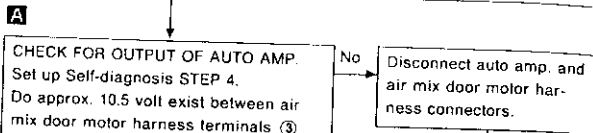
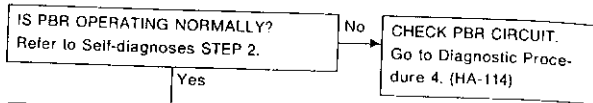

Code No.	Air mix door operation	Terminal No.		Voltage V
		③	⑤	
42 → 43	Cold → Hot	⊕	⊖	Approx. 10.5
46 → 41	Hot → Cold	⊖	⊕	
-	Stop	-	-	0

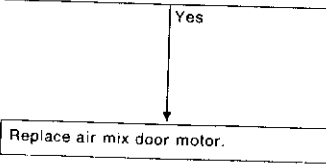
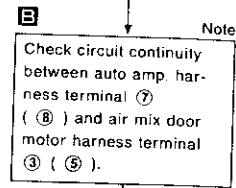

**Note:**  
 If the result is NG after checking circuit continuity, repair harness or connector.

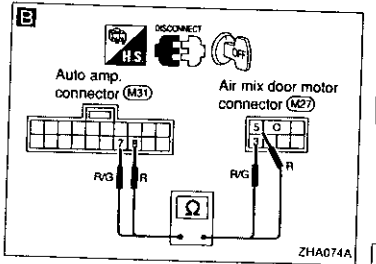
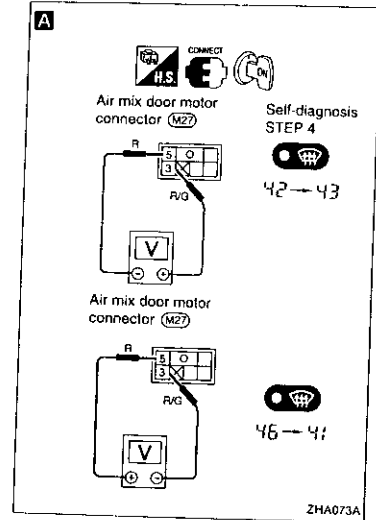

**Diagnostic Procedure 8**

**SYMPTOM:** Bi-level (B/L) door motor does not operate normally.  
 • Perform Self-diagnosis STEP 4 before referring to the following flow chart.

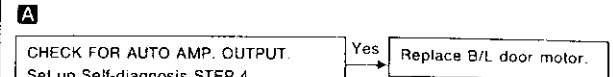

Code No.	B/L door condition	Terminal No.		Voltage V
		①	②	
42 → 43	OPEN → CLOSE	⊕	⊖	Approx. 12
45 → 41	CLOSE → OPEN	⊖	⊕	

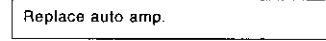
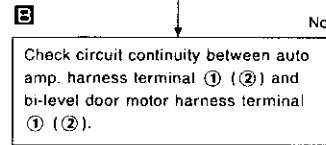
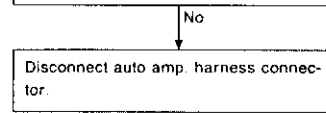

**Note:**  
 If the result is NG after checking circuit continuity, repair harness or connector.

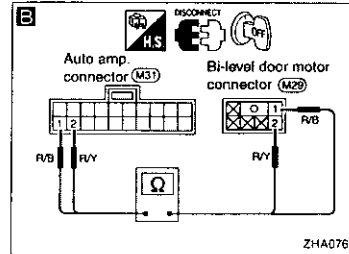
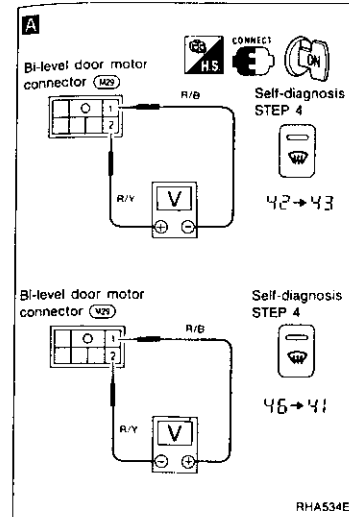



**Diagnostic Procedure 9**

**SYMPTOM:** Blower motor operation is malfunctioning under out of Starting Fan Speed Control.

- Perform Preliminary Check 5 before referring to the following flow chart.

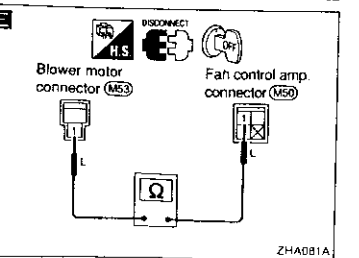
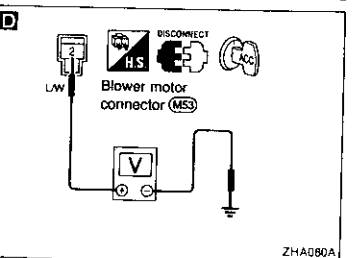
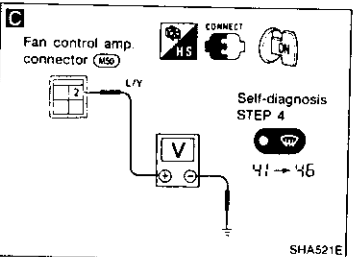
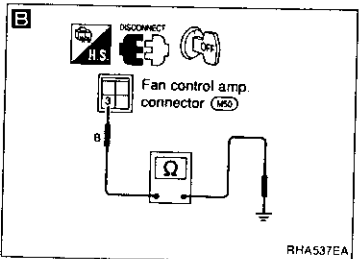
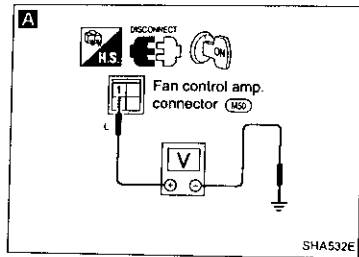

**A**  
CHECK POWER SUPPLY FOR FAN CONTROL AMP.  
Disconnect fan control amp. harness connector.  
Do approx. 12 volts exist between fan control amp. harness terminal ① and body ground?

**D**  
CHECK POWER SUPPLY FOR BLOWER MOTOR.  
Disconnect blower motor harness connector.  
Do approx. 12 volts exist between blower motor harness terminal ② and body ground?

**B**  
CHECK BODY GROUND CIRCUIT FOR FAN CONTROL AMP.  
Does continuity exist between fan control amp. harness terminal ③ and body ground?

**E**  
Check circuit continuity between blower motor harness terminal ① and fan control amp. harness terminal ①.

Reconnect fan control amp. harness connector.

**C**  
CHECK FOR OUTPUT OF AUTO AMP.  
Set up Self-diagnosis STEP 4.  
Measure voltage across fan control amp. harness terminal ② and body ground.

Code No.	Terminal No.		Voltage
	⊕	⊖	
41 → 46	②	Body ground	Approx. 2 - 3V

Replace fan control amp.

**Note:**  
If the result is NG after checking circuit continuity, repair harness or connector.

**Diagnostic Procedure 9 (Cont'd)**

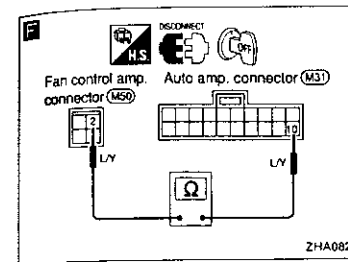

Disconnect auto amp. and fan control amp. harness connector.

**F**  
Does continuity exist between auto amp harness terminal ⑩ and fan control amp. harness terminal ②?

Replace auto amp.

**Note:**  
If the result is NG after checking circuit continuity, repair harness or connector.

## Diagnostic Procedure 10

**SYMPTOM:** Magnet clutch does not engage after performing Preliminary Check 6.

- Perform Preliminary Check 6 before referring to the flow chart.

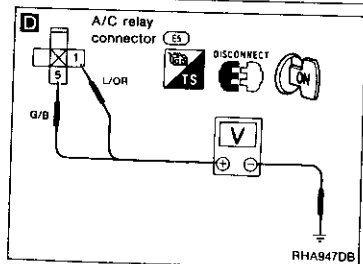
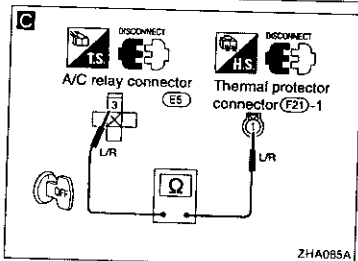
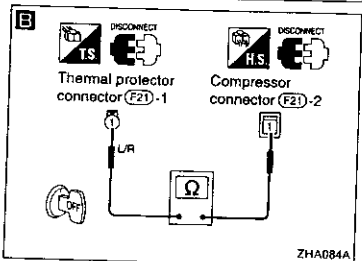
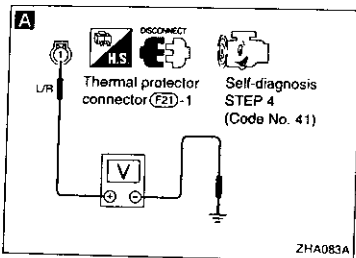
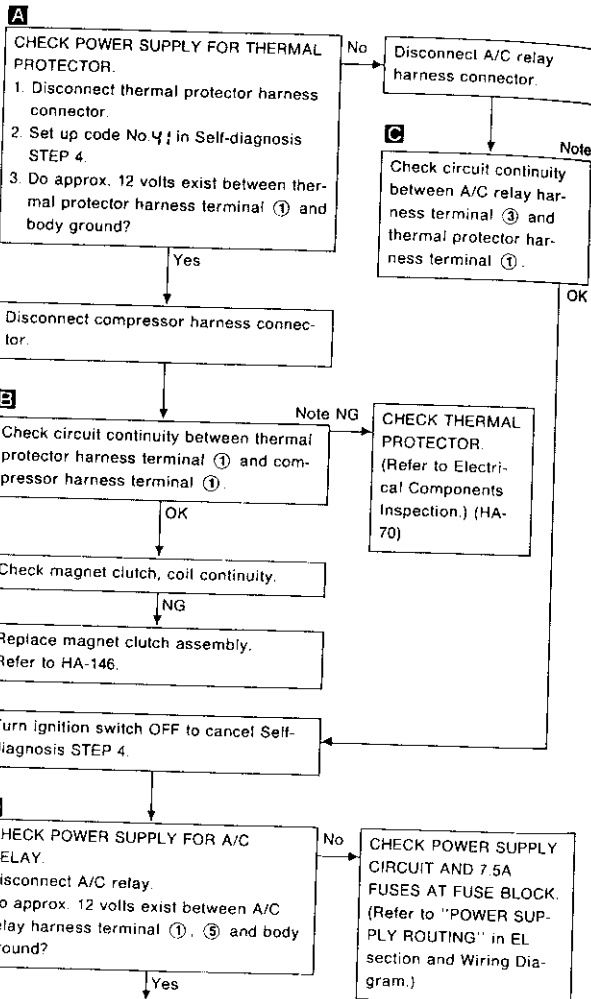

Note:

If the result is NG after checking circuit continuity, repair harness or connector.

## Diagnostic Procedure 10 (Cont'd)

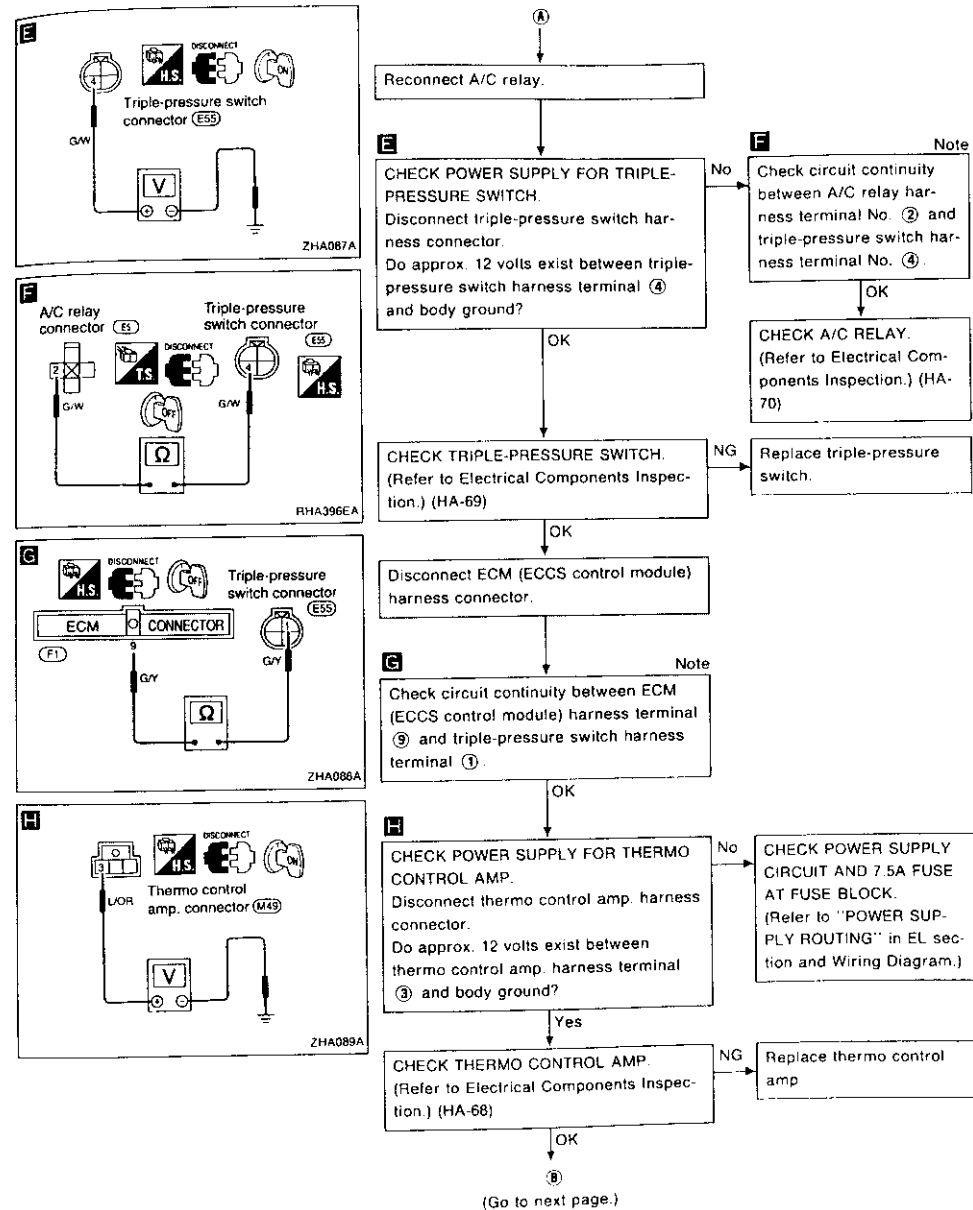

Note:

If the result is NG after checking circuit continuity, repair harness or connector.

Diagnostic Procedure 10 (Cont'd)

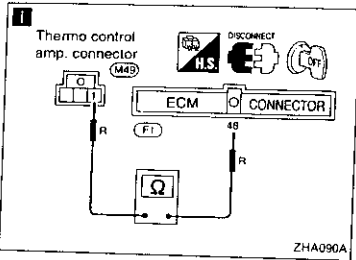

ZHA090A

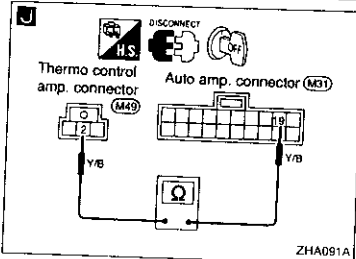

ZHA091A

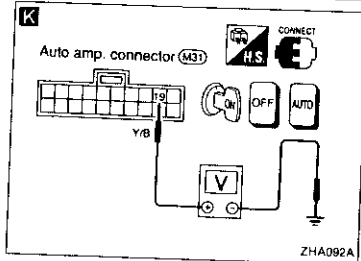

ZHA092A

**I** Note  
Check circuit continuity between ECM (ECCS control module) harness terminal (46) and thermo control amp. harness terminal (1).

Disconnect auto amp. harness connector.

**J** Note  
Check circuit continuity between auto amp. harness terminal (19) and thermo control amp. harness terminal (2).

Reconnect auto amp. harness connector.

**K** CHECK FOR AUTO AMP. OUTPUT. Measure voltage between auto amp. harness terminal (19) and body ground.

Condition	Terminal No.		Voltage
	⊕	⊖	
Auto switch ON	19	Body ground	Approx. 0V
OFF switch ON			Approx. 12V

NG → Replace auto amp.

OK  
CHECK ECM (ECCS CONTROL MODULE). (Refer to EC section.)

Note:  
If the result is NG after checking circuit continuity, repair harness or connector.

Control Linkage Adjustment

MODE DOOR

1. Install mode door motor on heater unit and connect it to main harness.
2. Set up code No. 45 in Self-diagnosis STEP 4.
3. Make sure mode door operates properly when changing from code No. 41 to 46 by pushing DEF switch.

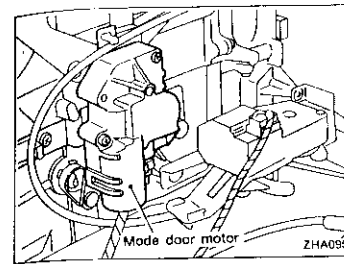

41	42	43	44	45	46
VENT	B/L	B/L	FOOT	F/D	DEF

AIR MIX DOOR

1. Install air mix door motor on heater unit and connect it to main harness.
2. Set up code No. 41 in Self-diagnosis STEP 4.
3. Move air mix door lever by hand and hold it in full cold position.
4. Attach air mix door lever to rod holder.
5. Make sure air mix door operates properly when changing from code No. 41 to 46 by pushing DEF switch.

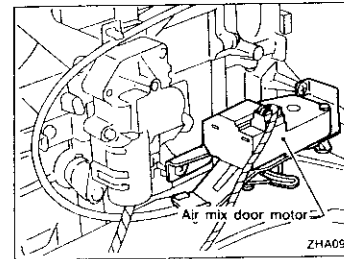

41	42	43	44	45	46
Full cold			Full hot		

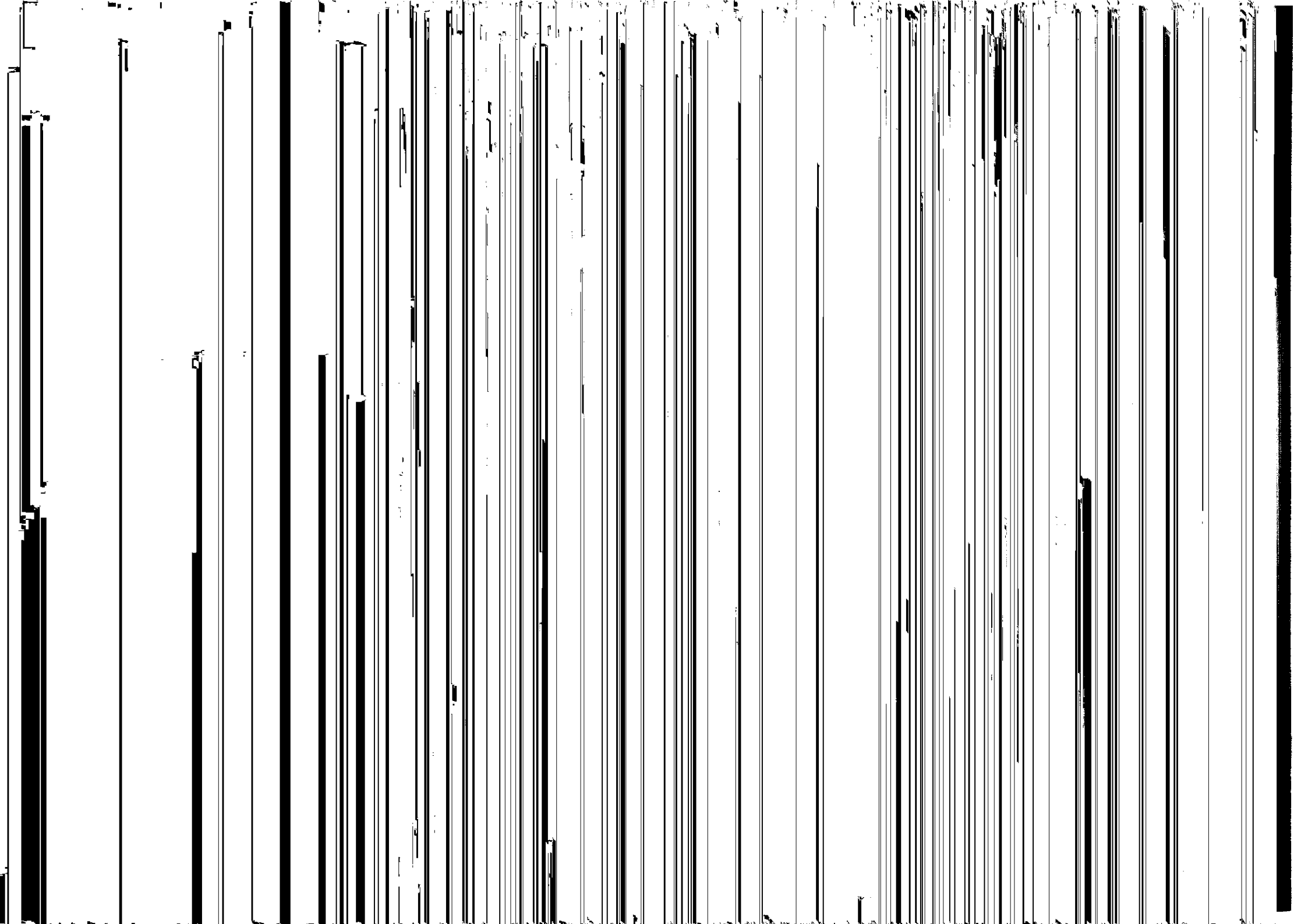

## DESCRIPTION

AUTO

## Ambient Input Components (Cont'd)

## RESISTOR

Sensor is attached to the hood rock stay. It detects temperature and converts it into a resistance then input to the auto amp.

Measuring ambient sensor harness connector, measure resistance between terminals ① and ② at sensor harness using the table below.

Temperature °C (°F)	Resistance kΩ
(5)	12.73
(14)	9.92
(23)	7.80
(32)	6.19
(41)	4.95
(50)	3.99
(59)	3.24
(68)	2.65
(77)	2.19
(86)	1.81
(95)	1.51
(104)	1.27
(113)	1.07

## CURRENT SENSOR

Sensor is located on the LH defroster grille. It detects current entering through windshield by means of a current sensor and converts it into a current value which is then input to the auto amp.

Measure current between terminals ① and ② at vehicle harness using the table below.

Current mA	Output voltage V
0	5
05	4.2
1	3.4
15	2.6
2	1.8
25	1.0

When installing sunload sensor, select a place where sun can directly hit it.

**Control System Automatic Amplifier (Auto amp.)**

The auto amplifier has a built-in microcomputer which processes information sent from various sensors needed for air conditioning operation. The air mix door motor, mode door motor, intake door motor, bi-level door motor, blower motor and compressor are then controlled.

The auto amp. is unitized with control mechanisms. Signals from various switches are directly entered into auto amplifier. Self-diagnostic functions are also built into auto amp. to provide quick check of malfunctions in the auto air conditioning system.

**PROCESS**

ircuit" for  
ient tem-  
ng circuit  
ensor. It  
crease of  
conds.  
a cup of  
ough the  
he ambi-  
tempera-  
compart-  
rea. The

**SUNLOAD INPUT PROCESS**

The auto amp. also includes a processing circuit which "average" the variations in detected sunload over a period of time. This prevents drastic swings in the ATC system operation due to small or quick variations in detected sunload.

For example, consider driving along a road bordered by an occasional group of large trees. The sunload detected by the sunload sensor will vary whenever the trees obstruct the sunlight. The processing circuit averages the detected sunload over a period of time. As a result, the effect the above mentioned does not cause any change in the ATC system operation. On the other hand, shortly after entering a long tunnel, the system will recognize the change in sunload, and the system will react accordingly.

**Control System Output Components**

(temperature control)

are:

**System operation**

Temperature set by Potentio Temperature Control (PTC) is compensated through setting temperature correction circuit to determine target temperature.

Auto amp. will operate air mix door motor to set air conditioning system in HOT or COLD position, depending upon relationship between conditions (target temperature, sunload, in-vehicle temperature, and ambient temperature) and conditions (air mix door position and compressor operation).

**Control System Output Components (Cont'd)**

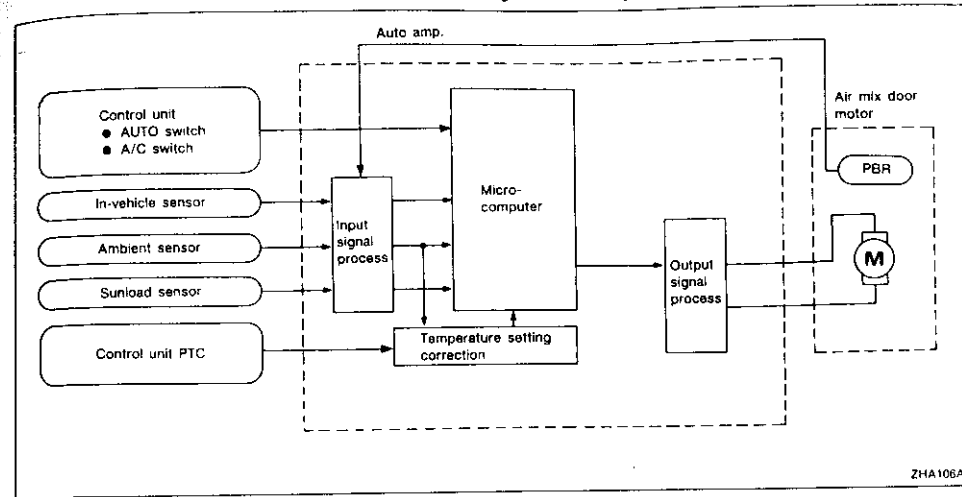

ZHA108A

**Air mix door control specification**

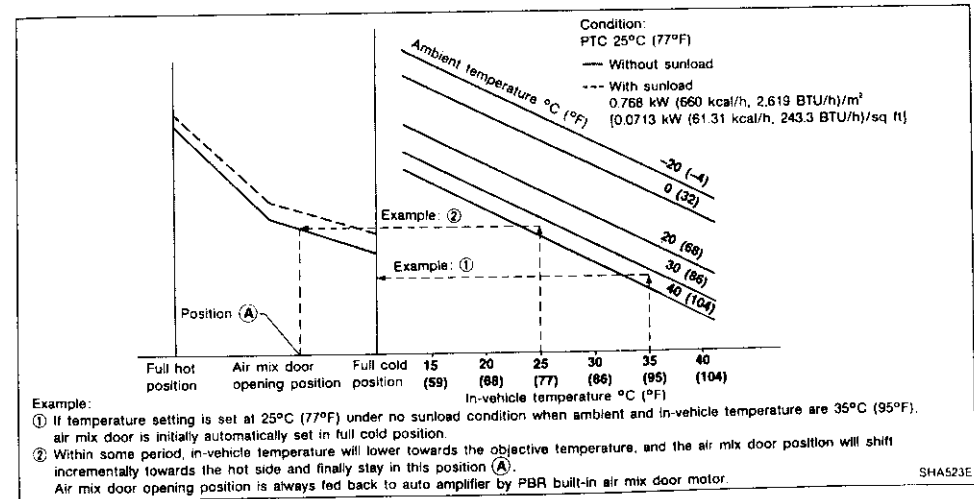

SHAS23E

**AIR MIX DOOR MOTOR**

The air mix door motor is attached to the bottom of the heater unit. It rotates so that the air mix door is opened to a position set by the auto amp. Motor rotation is then conveyed through a shaft and air mix door position is then fed back to the auto amp. by PBR built-in air mix door motor.

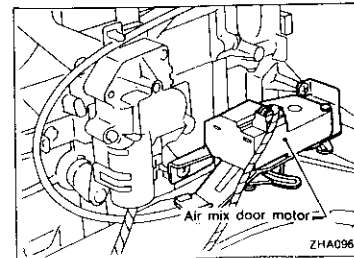

ZHA096A

## SYSTEM DESCRIPTION

AUTO

### Control System Output Components (Cont'd) Air mix door operation

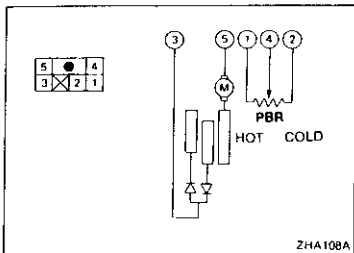

ZHA108A

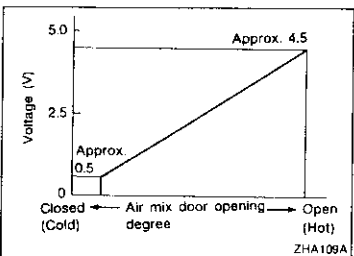

ZHA109A

3	5	Air mix door operation	Direction of lever movement
⊕	⊖	COLD → HOT	Clockwise (Toward passenger compartment)
—	—	STOP	STOP
⊖	⊕	HOT → COLD	Counterclockwise (Toward engine compartment)

### PBR characteristics

Measure voltage between terminals ④ and ② at vehicle harness side.

## MODE DOOR CONTROL

### Component parts

Mode door control system components are:

- 1) Auto amp.
- 2) Mode door motor
- 3) PBR
- 4) In-vehicle sensor
- 5) Ambient sensor
- 6) Sunload sensor

### System operation

The auto amp. computes the air discharge conditions according to the ambient temperature and the in-vehicle temperature. The computed discharge conditions are then corrected for sunload. By this correction, it is determined through which outlets air will flow into the passenger compartment.

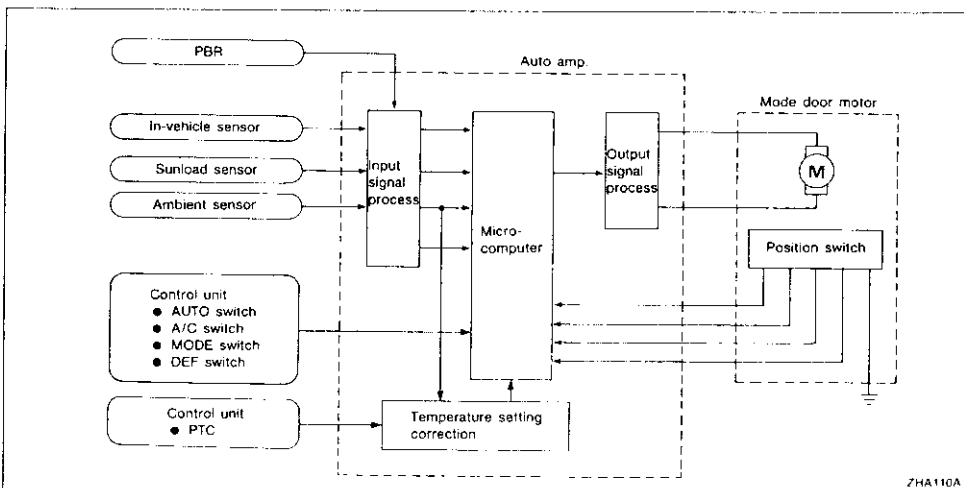

ZHA110A

HA-132

## SYSTEM DESCRIPTION

AUTO

### Control System Output Components (Cont'd) Mode door control specification

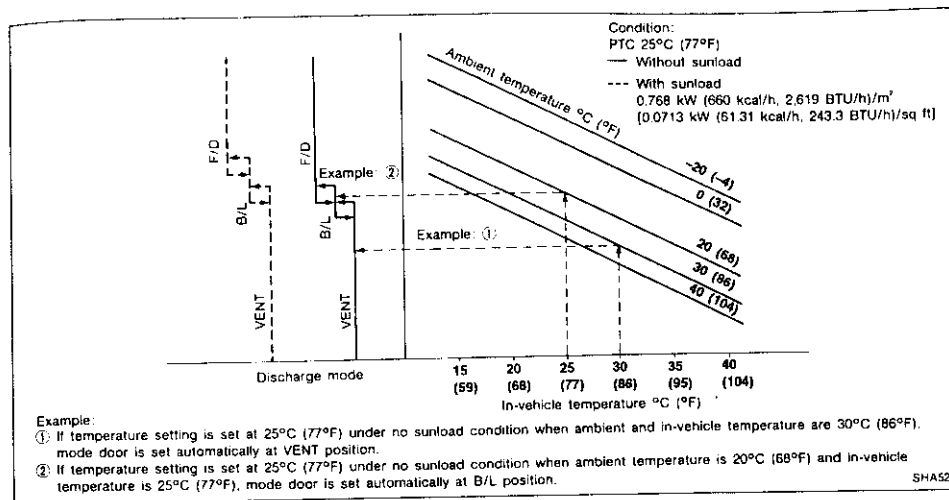

SHA524E

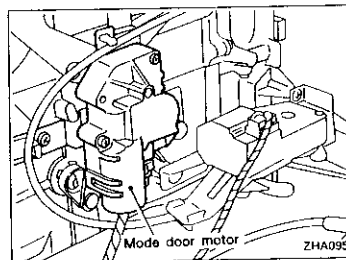

ZHA095A

### MODE DOOR MOTOR

The mode door motor is attached to the heater unit. It rotates so that air is discharged from the outlet set by the auto amp. Motor rotation is conveyed to a link which activates the mode door.

7	8	Mode door operation	Direction of side link rotation
⊕	⊖	VENT → DEF	Counterclockwise
—	—	STOP	STOP
⊖	⊕	DEF → VENT	Clockwise

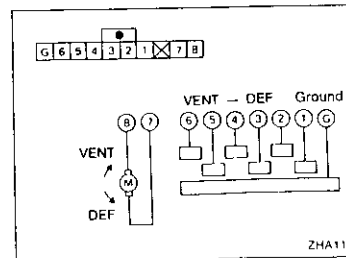

ZHA112A

HA-133

## SYSTEM DESCRIPTION

AUTO

### INTAKE DOOR CONTROL

#### Components parts

Intake door control system components are:

- 1) Auto amp.
- 2) Intake door motor
- 3) PBR
- 4) In-vehicle sensor
- 5) Ambient sensor
- 6) Sunload sensor

### Control System Output Components (Cont'd)

#### System operation

The intake door control determines intake door position based on the ambient temperature and the in-vehicle temperature. When the DEF button is pushed, the auto amp. sets the intake door at the "Fresh" position.

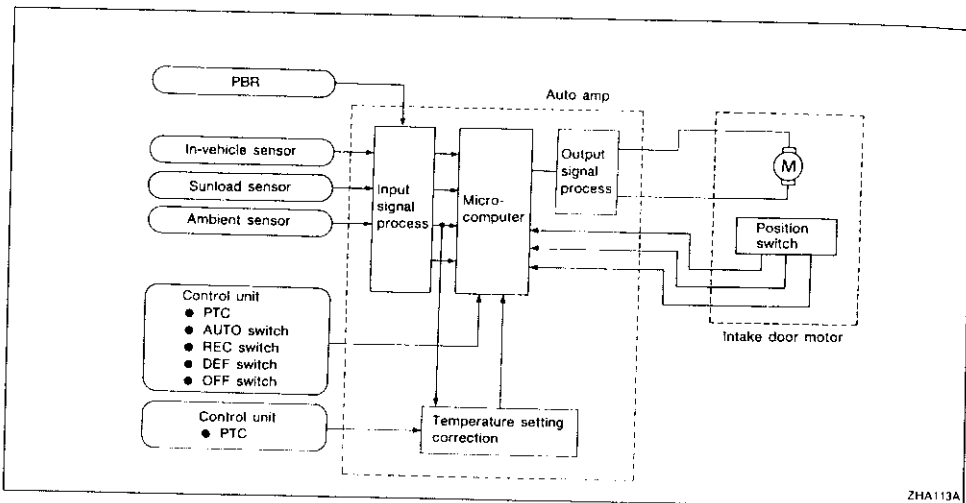

ZHA113A

### Intake door control specification

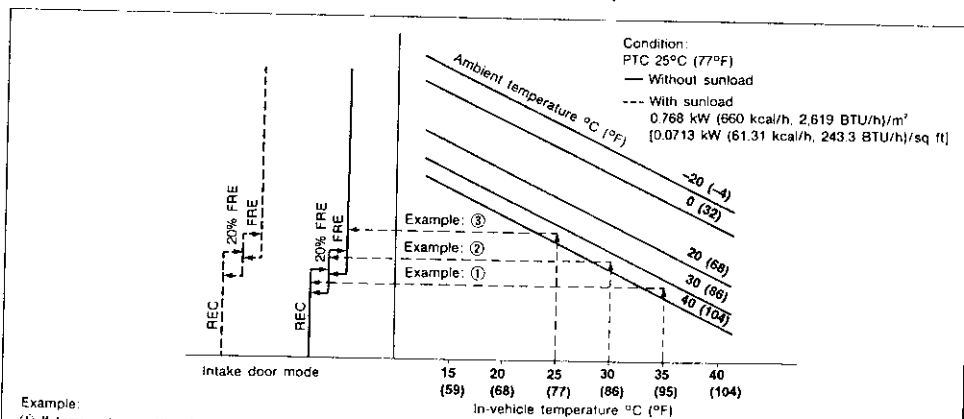

Example:

- ① If temperature setting is set at 25°C (77°F) under no sunload condition when ambient and in-vehicle temperature are 35°C (95°F), intake door is set automatically at REC position to make in-vehicle temperature cool down efficiently.
- ② In-vehicle temperature will lower and when 30°C (86°F) is reached, intake door will shift to 20% FRE position.
- ③ In the state when in-vehicle temperature reaches the objective temperature 25°C (77°F), intake door is set at FRE position.

SHA525E

## SYSTEM DESCRIPTION

AUTO

### Control System Output Components (Cont'd)

#### INTAKE DOOR MOTOR

The intake door motor is attached to the intake unit. It rotates so that air is drawn from inlets set by the auto amp. Motor rotation is conveyed to a lever which activates the intake door.

#### Intake door motor operation

6	7	Intake door operation	Movement of link rotation
⊕	⊖	REC → FRE	Counterclockwise
—	—	STOP	STOP
⊖	⊕	FRE → REC	Clockwise

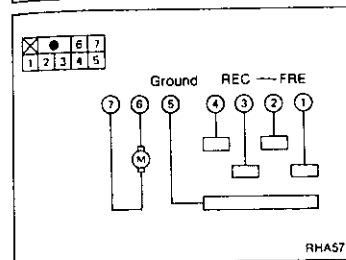
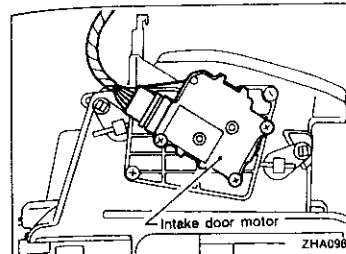

### FAN SPEED CONTROL

#### Component parts

Fan speed control system components are:

- 1) Auto amp.
- 2) Fan control amplifier
- 3) PBR

- 4) In-vehicle sensor
- 5) Ambient sensor
- 6) Sunload sensor
- 7) Thermal transmitter

#### System operation

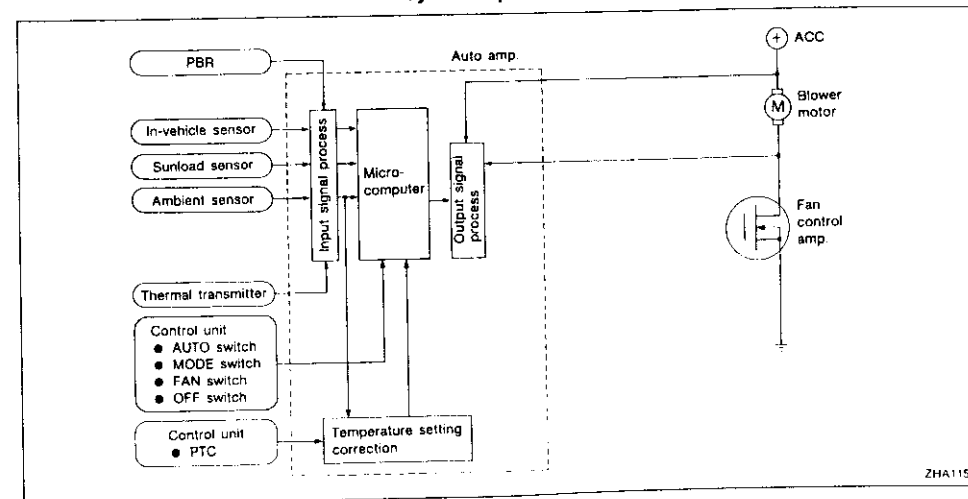

ZHA115A



Control System Output Components (Cont'd)

**AUTOMATIC MODE**

In the automatic mode, the blower motor speed is calculated by the auto amp. based on inputs from the PBR, in-vehicle sensor, sunload sensor, and ambient sensor. The blower motor applied voltage ranges from approximately 4 volts (lowest speed) to 12 volts (highest speed).

To control blower speed (in the range of 2V to 3V), the auto amp. supplies a signal to the fan control amplifier. Based on this signal, the fan control amplifier controls the current flow from the blower motor to ground.

**STARTING FAN SPEED CONTROL**

**Start up from "COLD SOAK" condition (Automatic mode)**

In a cold start up condition where the engine coolant temperature is below 50°C (122°F) and mode door position is BI-LEVEL, F/D or FOOT, the blower will not operate for a short period of time (up to 150 seconds). The exact start delay time varies depending on the ambient and in-vehicle temperature.

In the most extreme case (very low ambient) the blower starting delay will be 150 seconds. After this delay, the blower will operate at low speed

until the engine coolant temperature rises above 50°C (122°F). Then the blower speed will increase to the objective speed.

**Start up from normal or "HOT SOAK" condition (Automatic mode)**

The blower will begin operation momentarily after the AUTO switch is pushed. The blower speed will gradually rise to the objective speed over a time period of 8 seconds or less (actual time depends on the objective blower speed).

If the in-vehicle temperature is 35°C (95°F) or more, the blower will not operate for 3 seconds after AUTO switch is pushed.

**BLOWER SPEED COMPENSATION**

**Sunload**

When the in-vehicle temperature and the set temperature are very close, the blower will operate at low speed. With the mode door in the VENT position, the low speed varies depending on the sunload. During conditions of high sunload, the blower low speed will rise (approx. 6.0V). During lesser sunload conditions, the low speed will drop to "normal" low speed (approx. 5.0V).

Fan speed control specification

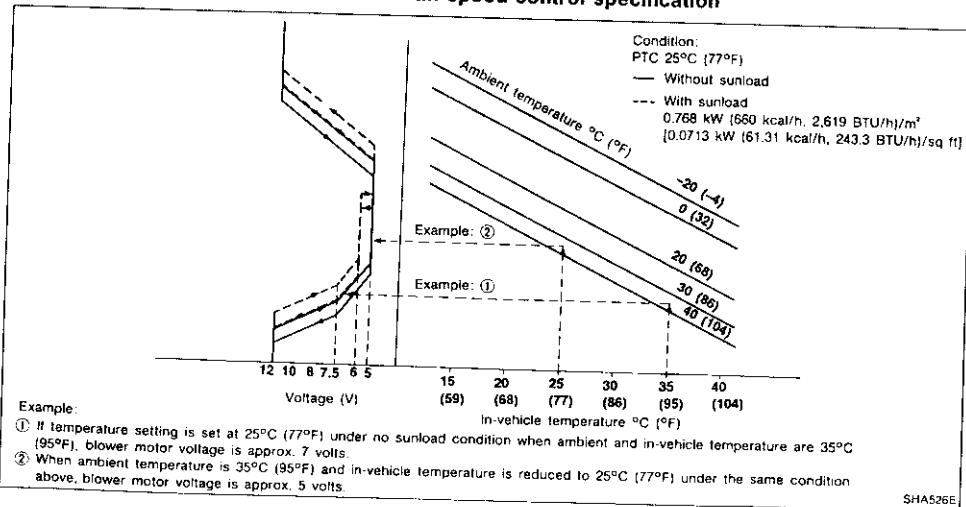

Control System Output Components (Cont'd)

**FAN CONTROL AMPLIFIER**

The fan control amplifier is located on the cooling unit. It amplifies the base current flowing from the auto amp. to change the blower speed within the range of 4V to 12V.

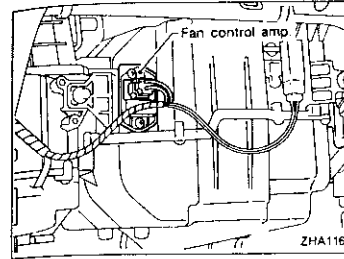

**MAGNET CLUTCH CONTROL**

The ECM (ECCS control module) controls compressor operation using inputs from the throttle position sensor and auto amplifier.

**Acceleration cut control**

The ECM (ECCS control module) will turn the compressor "ON" or "OFF" based on the signal from the throttle position sensor.

HFC-134a (R-134a) Service Procedure  
SETTING OF SERVICE TOOLS AND EQUIPMENT

DISCHARGING REFRIGERANT

WARNING:

Avoid breathing A/C refrigerant and lubricant vapor or mist. Exposure may irritate eyes, nose and throat. Remove HFC-134a (R-134a) from A/C system using certified service equipment meeting requirements of HFC-134a (R-134a) recycling equipment or HFC-134a (R-134a) recovery equipment. If accidental system discharge occurs, ventilate work area before resuming service. Additional health and safety information may be obtained from refrigerant and lubricant manufacturers.

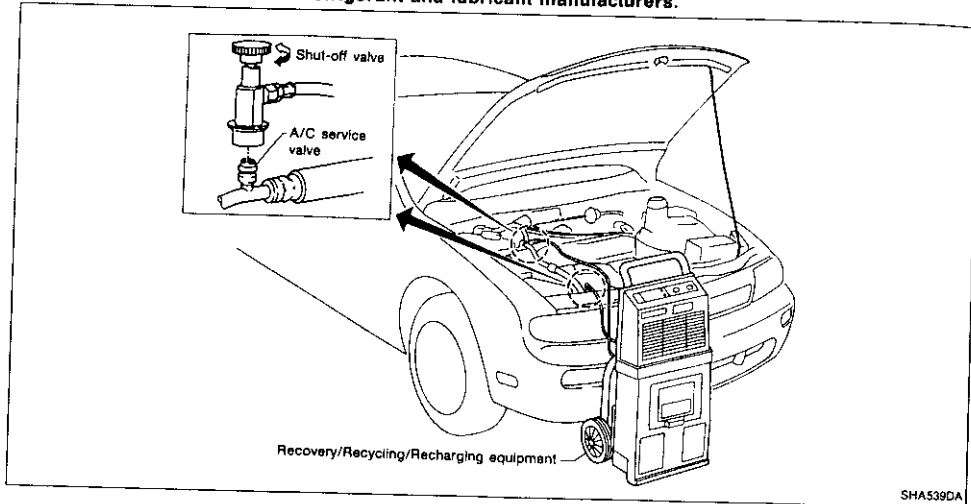

EVACUATING SYSTEM AND CHARGING REFRIGERANT

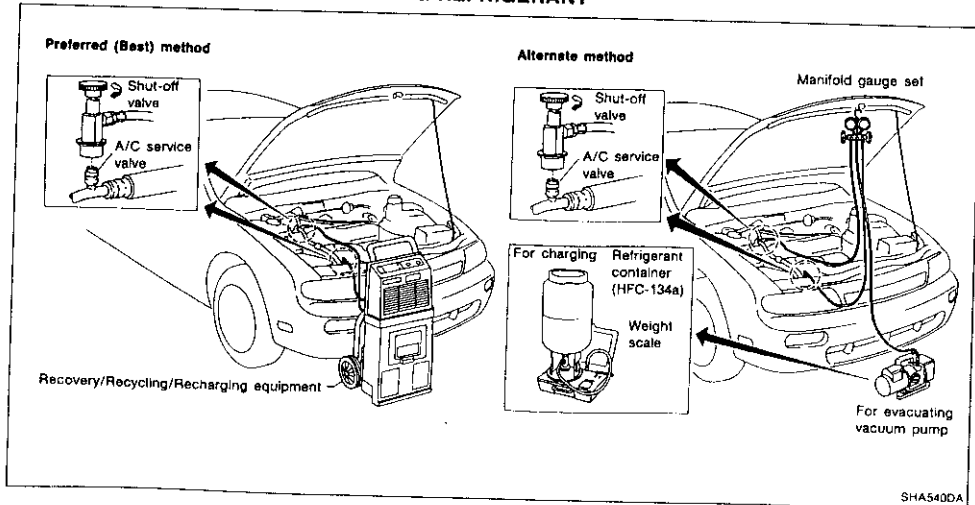

HFC-134a (R-134a) Service Procedure (Cont'd)

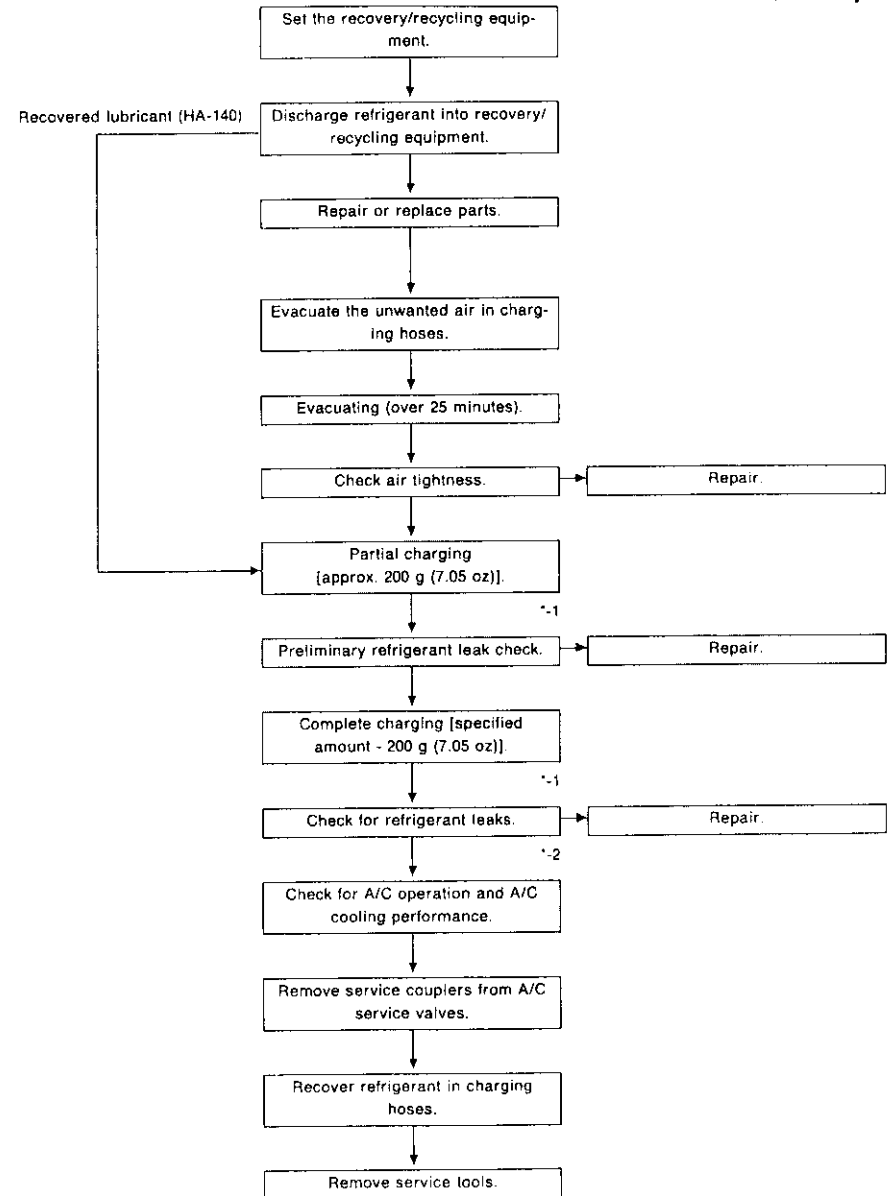

Note \*-1 Before charging refrigerant, ensure engine is off.

\*-2 Before checking for leaks, start engine to activate air conditioning system then turn it off. Service valve caps must be attached to valves (to prevent leakage).

ity in  
mpressor circulates  
dd lubricant to com-  
or after a large gas  
intain the specified

roperly, the following  
d compressor  
cooling (thermal

he flowchart shown

ws:

---

r temperature is

st the manifold  
pressure is 588 kPa

to the front face of

minutes.

he oil return opera-

ents, add the cor-

---

Remarks

---

if compressor is not  
replaced '1  
Large leak  
Small leak'2

is included in the

ent is needed.

Maintenance of Lubricant Quantity in Compressor (Cont'd)

1. Discharge refrigerant into the refrigerant recovery/recycling equipment. Measure oil discharged into the recovery/recycling equipment.
2. Remove the drain plug of the "old" (removed) compressor (applicable only to V-5, V-6 or DKS-16H compressor). Drain the oil into a graduated container and record the amount of drained oil.
3. Remove the drain plug and drain the oil from the "new" compressor into a separate, clean container
4. Measure an amount of new oil installed equal to amount drained from "old" compressor. Add this oil to "new" compressor through the suction port opening.
5. Measure an amount of new oil equal to the amount recovered during discharging. Add this oil to "new" compressor through the suction port opening.
6. Torque the drain plug.  
V-5 or V-6 compressor: 18 - 19 N·m (1.8 - 1.9 kg-m, 13 - 14 ft-lb)  
DKS-16H compressor: 14 - 16 N·m (1.4 - 1.6 kg-m, 10 - 12 ft-lb)
7. If the liquid tank also needs to be replaced, add an additional 5 mℓ (0.2 Imp fl oz) of oil at this time.  
Do not add this 5 mℓ (0.2 Imp fl oz) of oil if only replacing the compressor.

Oil adjusting procedure for compressor replacement

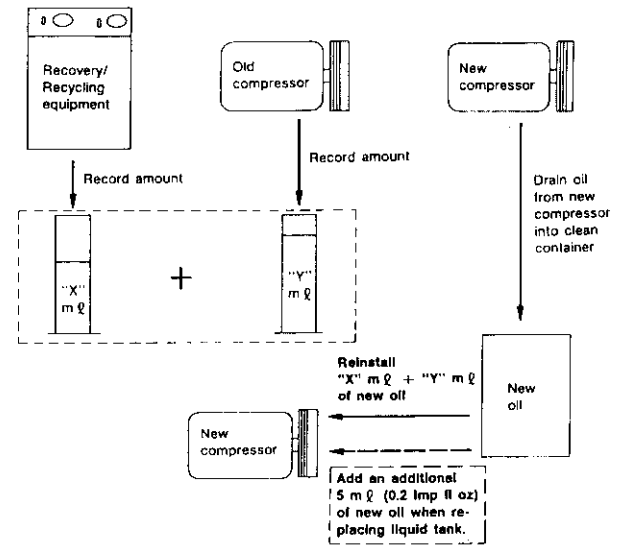

R1A065DC

Regarding "Precautions for Refrigerant

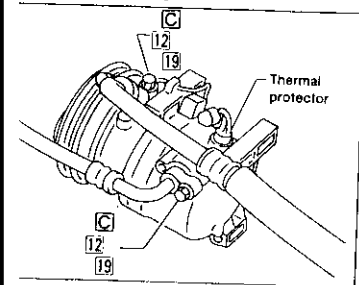
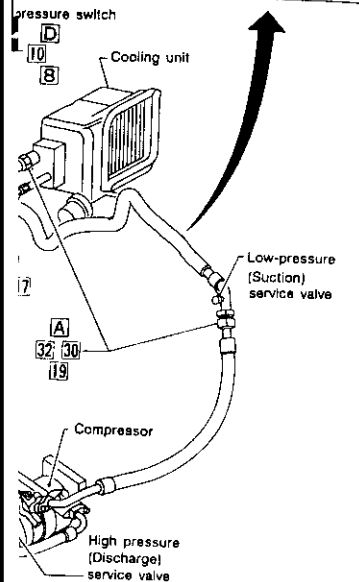
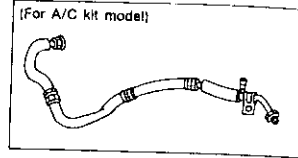

- (Tightening torque)
  - (Wrench size)
  - (O-ring size)
  - A** : 25 - 34 (2.5 - 3.5, 18 - 25)
  - B** : 10 - 20 (1.0 - 2.0, 7 - 14)
  - C** : 8 - 11 (0.8 - 1.1, 5.8 - 8.0)
  - D** : 2.9 - 3.9 (0.3 - 0.4, 2.2 - 2.9)
- SHA504E

## Refrigerant Lines (Cont'd)

RHD MODEL

SEC. 271-272-276

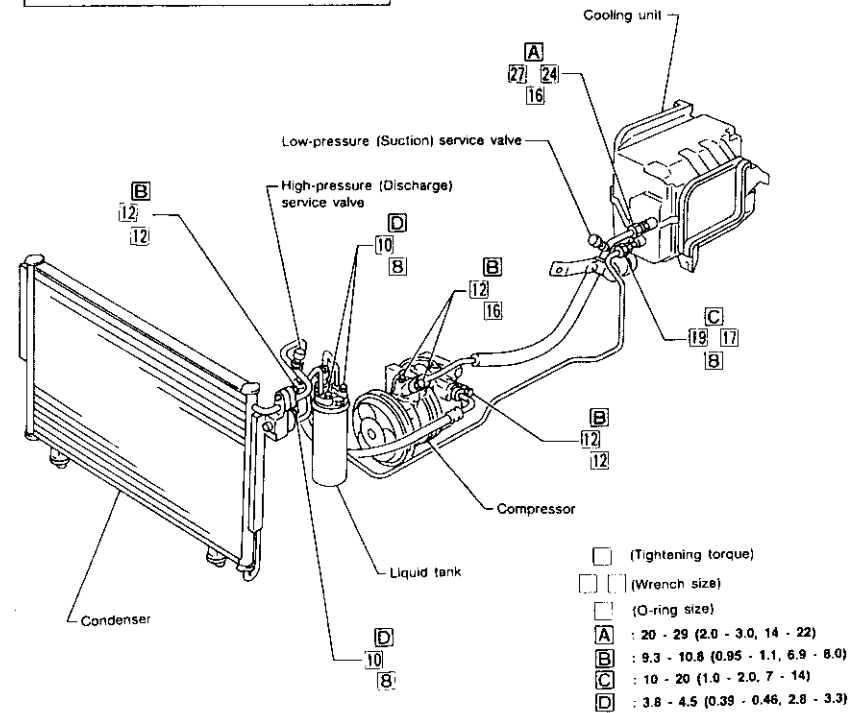
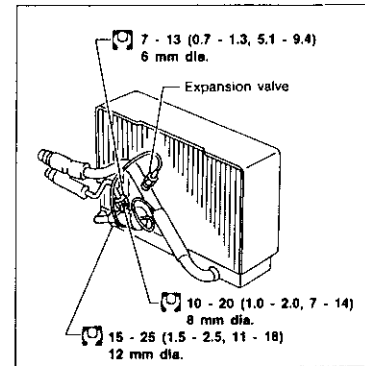

- (Tightening torque)
  - (Wrench size)
  - (O-ring size)
  - A** : 20 - 29 (2.0 - 3.0, 14 - 22)
  - B** : 9.3 - 10.8 (0.95 - 1.1, 6.9 - 8.0)
  - C** : 10 - 20 (1.0 - 2.0, 7 - 14)
  - D** : 3.8 - 4.5 (0.39 - 0.46, 2.8 - 3.3)
- : N·m (kg·m, ft·lb)

GI  
WA  
EM  
LC  
EC  
FE  
CL  
WT  
AT  
PD  
FA  
NA  
BB  
ST  
BS  
BT  
HA  
EL  
DX

Compressor Mounting

SEC. 274-275

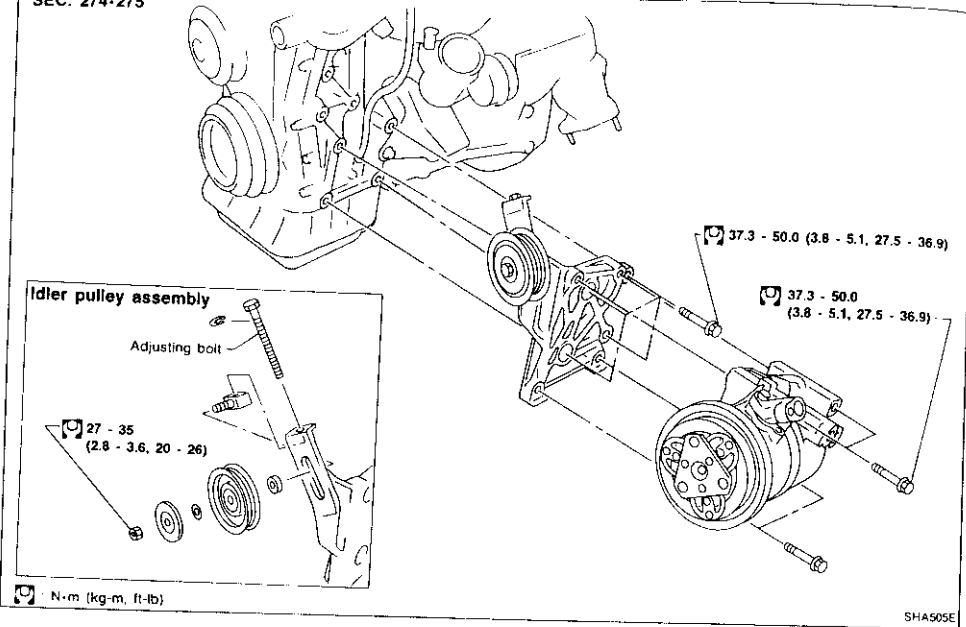

Belt Tension

- Refer to MA section ("Checking Drive Belts", "ENGINE MAINTENANCE").

Fast Idle Control Device (FICD)

- Refer to EC section ("IACV-FICD SOLENOID VALVE", "TROUBLE DIAGNOSES").

Compressor — Model DKV-14C (ZEXEL make)

SEC. 274

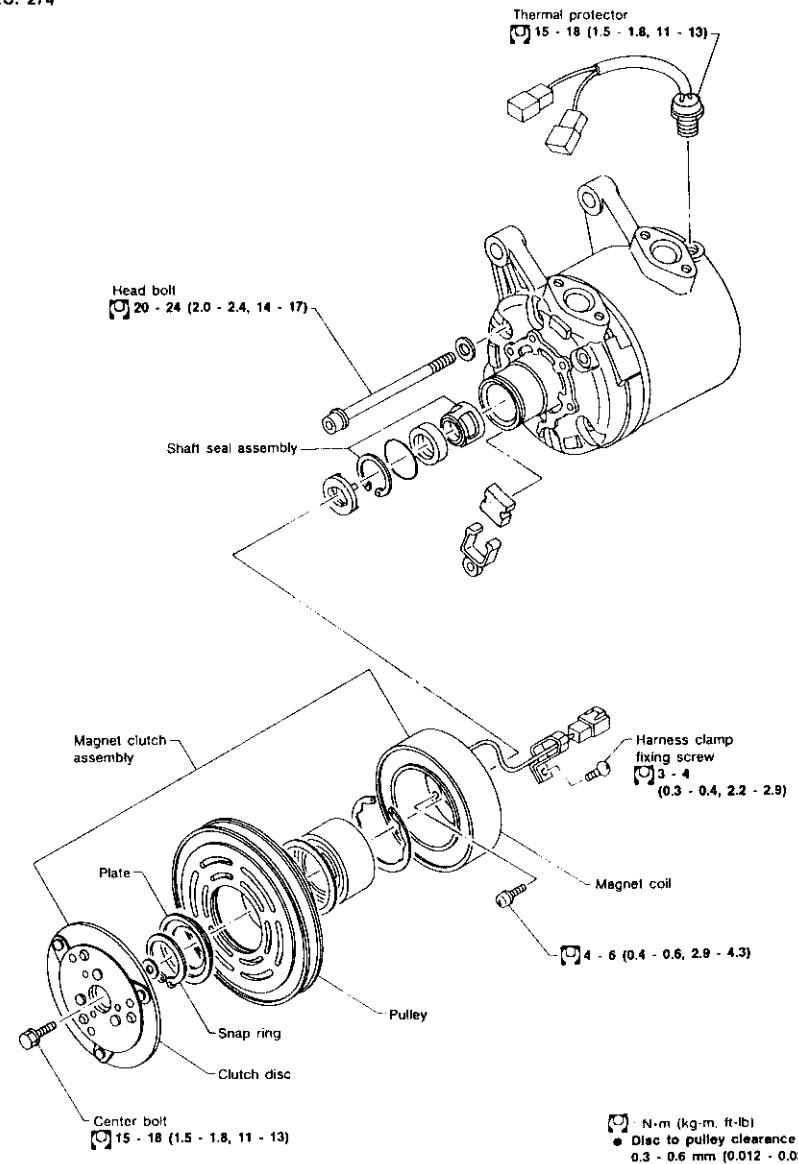

N·m (kg·m, ft·lb)  
 • Disc to pulley clearance:  
 0.3 - 0.6 mm (0.012 - 0.024 in)

HA

Compressor — Model DKV-14C (ZEXEL make)  
(Cont'd)

## COMPRESSOR CLUTCH

## Removal

- When removing center bolt, hold clutch disc with clutch disc wrench.

- Using clutch disc puller clutch disc can be removed easily.

## Inspection

## Clutch disc

If the contact surface shows signs of damage due to excessive heat, the clutch disc and pulley should be replaced.

## Pulley

Check the appearance of the pulley assembly. If the contact surface of the pulley shows signs of excessive grooving due to slippage, both the pulley and clutch disc should be replaced. The contact surfaces of the pulley assembly should be cleaned with a suitable solvent before reinstallation.

## Coil

Check coil for loose connection or cracked insulation.

## Installation

- Position coil assembly on compressor body. Be sure that the electrical terminals are reassembled in the original position. Install and tighten coil mounting screws evenly.

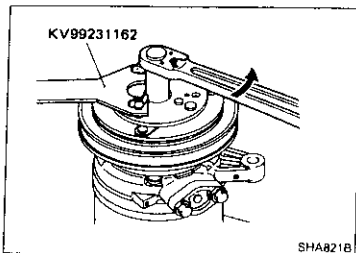

SHA821B

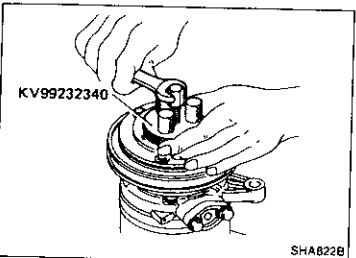

SHA822B

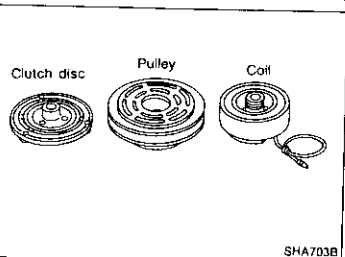

SHA703B

Compressor — Model DKV-14C (ZEXEL make)  
(Cont'd)

- Press pulley assembly onto the neck of coil assembly using pulley installer.
- Wipe oil thoroughly off the clutch surface.

## Adjustment

- Select adjusting shim(s) which give(s) the correct clearance between pulley and clutch disc.
- Using a plastic mallet, tape clutch disc in place on drive shaft.
- Do not use excessive force with a plastic mallet or in a press, or internal damages may result.
- Place spring washer and center bolt onto drive shaft. Tighten center bolt to drive clutch wheel onto drive shaft.

- Check clearance around the entire periphery of clutch disc.

## Disc-to-pulley clearance:

0.3 - 0.6 mm (0.012 - 0.024 in)

If the specified clearance is not obtained, replace adjusting spacer and readjust.

## Break-in operation

When replacing compressor clutch assembly, always conduct the break-in operation. This is done by engaging and disengaging the clutch about thirty times.

Break-in operation raises the level of transmitted torque.

## THERMAL PROTECTOR

## Inspection

- When servicing, do not allow foreign material to get into compressor.
- Check continuity between two terminals.

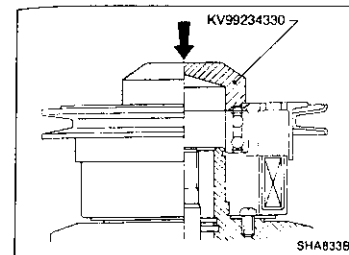

SHA833BA

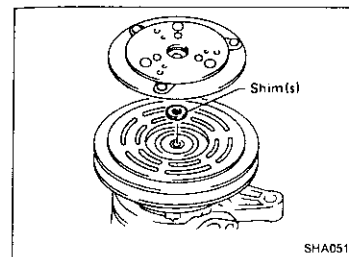

SHA051C

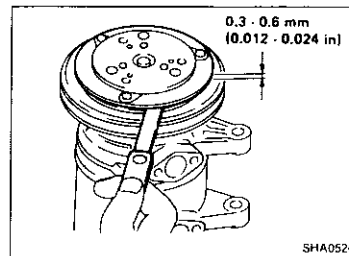

SHA052C

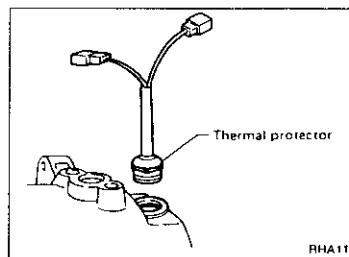

RHA113

Overhaul — Push Control Unit Assembly

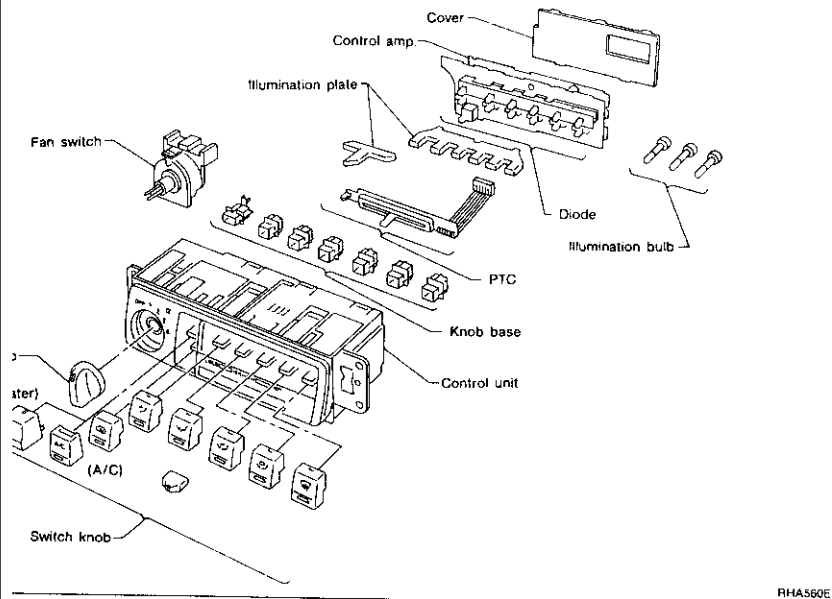

RHA560E

Disassembly

1. Remove switch knobs.  
Be careful not to scratch knobs during removal.

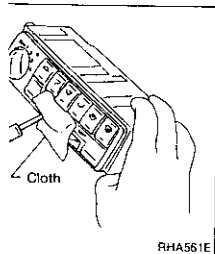

RHA561E

2. Remove fan switch knob.

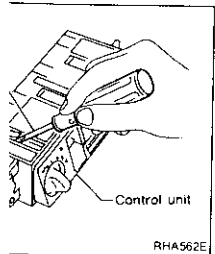

RHA562E

General Specifications

COMPRESSOR

Model	DKV-14C
Type	Vane rotary
Displacement	cm <sup>3</sup> (cu in)/Rev 140 (8.54)
Direction of rotation	Clockwise (Viewed from drive end)
Drive belt	Poly V type

LUBRICATION OIL

Model	ZEXEL make DKV-14C
Name	Nissan A/C System Oil Type R
Part No.	KLH00-RAGR0
Capacity	m <sup>3</sup> (Imp fl oz)
Total in system	200 (7.0)
Compressor (Service part) charging amount	200 (7.0)

REFRIGERANT

Type	HFC-134a (R-134a)
Capacity	kg (lb)
LHD model	0.70 - 0.80 (1.54 - 1.76)
RHD model	0.60 - 0.70 (1.32 - 1.54)

Inspection and Adjustment

ENGINE IDLING SPEED

When A/C is ON

- Refer to EC section ("Inspection and Adjustments", "SERVICE DATA AND SPECIFICATIONS").

BELT TENSION

- Refer to MA section ("Checking Drive Belts", "ENGINE MAINTENANCE").

COMPRESSOR

Model	DKV-14C
Clutch disc-pulley clearance	mm (in) 0.3 - 0.6 (0.012 - 0.024)

# ELECTRICAL SYSTEM

## SECTION **EL**

TO FOLLOW FLOW CHART IN  
DIAGNOSIS FOR AN ELECTRICAL

.....	42	GL
.....	42	
.....	43	WT
.....	44	
.....	45	
and Specifications (SDS).....	45	BT
WITCH.....	46	
.....	46	FB
.....	48	
ent.....	49	FB
ons.....	49	
thout Daytime Light System —.....	50	FB
tion.....	50	
.....	51	
— H/LAMP —.....	52	BT
ses.....	55	
yttime Light System —.....	56	BT
tion.....	56	
ime light system).....	57	
.....	58	FB
— DTRL —.....	59	
ses.....	62	
adlamp Aiming Control —.....	64	BT
.....	64	
— AIM —.....	66	FB
ient.....	70	
ses.....	71	
.....	72	EL
nse and Tail Lamps/System.....	72	
.....	72	FB
nse and Tail Lamps/ — TAIL/L —.....	74	
ng Diagram — STOP/L —.....	80	
iring Diagram — BACK/L —.....	81	



## CONTENTS (Cont'd.)

Front Fog Lamps/System Description.....	82	Front Wiper and Washer/Wiring Diagram — WIPER — .....	140
Front Fog Lamp/Wiring Diagram — F/FOG — .....	84	Trouble Diagnoses .....	142
Front Fog Lamp Aiming Adjustment .....	89	Front Wiper Amplifier Check .....	144
Rear Fog Lamp/System Description .....	90	Front Wiper Installation and Adjustment .....	144
Rear Fog Lamp/Wiring Diagram — R/FOG — .....	91	Front Washer Nozzle Adjustment .....	144
Turn Signal and Hazard Warning Lamps/System Description .....	93	Front Washer Tube Layout .....	145
Turn Signal and Hazard Warning Lamps/Schematic .....	95	Front Wiper Linkage .....	145
Turn Signal and Hazard Warning Lamps/Wiring Diagram — TURN — .....	96	Rear Wiper and Washer/System Description .....	147
Turn Signal and Hazard Warning Lamps/Trouble Diagnoses .....	101	Rear Wiper and Washer/Wiring Diagram — WIP/R — .....	149
Combination Flasher Unit Check .....	101	Rear Wiper Amplifier Check .....	151
Bulb Specifications .....	102	Rear Wiper Installation and Adjustment .....	151
<b>INTERIOR LAMP</b> .....	103	Rear Washer Nozzle Adjustment .....	151
Illumination/System Description .....	103	Rear Washer Tube Layout .....	152
Illumination/Schematic .....	104	Check Valve (For rear washer) .....	152
Illumination/Wiring Diagram — ILL — .....	105	Headlamp Washer/System Description .....	153
Interior, Spot and Trunk Room Lamps/System Description .....	110	Headlamp Washer/Wiring Diagram — HLC — .....	154
Bulb Specifications .....	110	Headlamp Washer Amplifier Check .....	156
Interior, Spot and Trunk Room Lamps/Wiring Diagram — INT/L — .....	111	Headlamp Washer Nozzle Adjustment .....	156
<b>METER AND GAUGES</b> .....	113	Headlamp Washer Tube Layout .....	156
System Description .....	113	Check Valve (For headlamp washer) .....	156
Combination Meter .....	114	<b>POWER WINDOW</b> .....	157
Speedometer, Tachometer, Temp. and Fuel Gauges/Wiring Diagram — METER — .....	115	System Description .....	157
Inspection/Fuel Gauge and Water Temperature Gauge .....	116	Schematic .....	159
Inspection/Tachometer .....	117	Wiring Diagram — WINDOW — .....	160
Inspection/Speedometer and Vehicle Speed Sensor .....	118	Trouble Diagnosis .....	163
Thermal Transmitter Check .....	120	<b>POWER DOOR LOCK</b> .....	169
Vehicle Speed Sensor Signal Check .....	120	System Description .....	169
Fuel Tank Gauge Unit Check .....	120	Wiring Diagram — D/LOCK — .....	171
Lead Switch .....	121	Trouble Diagnoses .....	173
<b>WARNING LAMPS AND BUZZER</b> .....	122	<b>POWER DOOR MIRROR</b> .....	175
Warning Lamps/Schematic .....	122	Wiring Diagram — MIRROR — .....	175
Warning Lamps/Wiring Diagram — WARN — .....	123	<b>ELECTRIC SUN ROOF</b> .....	179
Fuel Warning Lamp Sensor Check .....	129	Wiring Diagram — SROOF — .....	179
Oil Pressure Switch Check .....	129	<b>HORN, CIGARETTE LIGHTER AND CLOCK</b> .....	181
Diode Check .....	129	Wiring Diagram — HORN — .....	181
Warning Buzzer/System Description .....	130	<b>REAR WINDOW DEFOGGER AND DOOR MIRROR DEFOGGER</b> .....	185
Warning Buzzer/Wiring Diagram — CHIME — .....	131	System Description .....	185
Trouble Diagnoses — Warning Buzzer .....	133	Wiring Diagram — DEF — .....	186
Warning Buzzer Check .....	137	Trouble Diagnoses .....	188
<b>WIPER AND WASHER</b> .....	138	Filament Check .....	189
Front Wiper and Washer/System Description .....	138	<b>AUDIO AND POWER ANTENNA</b> .....	190

## CONTENTS (Cont'd.)

Antenna Rod Replacement .....	197	Trouble Diagnoses .....	230
Window Antenna Repair .....	198	<b>LOCATION OF ELECTRICAL UNIT</b> .....	249
<b>HEATED SEAT</b> .....	200	Engine Compartment .....	249
Wiring Diagram — H/SEAT — .....	200	Passenger Compartment .....	250
<b>MULTI-REMOTE CONTROL SYSTEM</b> .....	202	Trunk Compartment .....	252
System Description .....	202	<b>HARNESS LAYOUT</b> .....	253
Component Parts and Harness Connector Location .....	204	Outline .....	253
Schematic .....	205	Main Harness .....	254
Wiring Diagram — MULTI — .....	206	Engine Room Harness .....	258
Input/Output Operation Signal .....	210	Engine Control Harness .....	264
Trouble Diagnoses .....	211	Engine Harness .....	268
Replacing Remote Controller or Control Unit .....	217	Body Harness .....	270
<b>THEFT WARNING SYSTEM</b> .....	218	Tail Harness .....	274
System Description .....	218	Room Lamp Harness .....	276
Component Parts and Harness Connector Location .....	221	Air Bag and Seat Belt Pre-tensioner Harness .....	277
Schematic .....	222	Door Harness (LHD models) .....	278
Wiring Diagram — THEFT — .....	223	Door Harness (RHD models) .....	279
Input/Output Operation Signal .....	229	<b>SUPER MULTIPLE JUNCTION (SMJ)</b> .....	Foldout page

### WIRING DIAGRAM REFERENCE CHART

ECCS .....	EC SECTION
A/T CONTROL .....	AT SECTION
ANTI-LOCK BRAKING SYSTEM .....	BR SECTION
DIFFERENTIAL OIL COOLER .....	PD SECTION
AIR BAG AND SEAT BELT PRE-TENSIONER .....	PS SECTION
HEATER AND AIR CONDITIONER .....	HA SECTION

GI

MA

EM

LC

EC

FE

CI

MT

AT

PD

FA

RA

BR

ST

RS

BT

HA

EL

IOX

## PRECAUTIONS

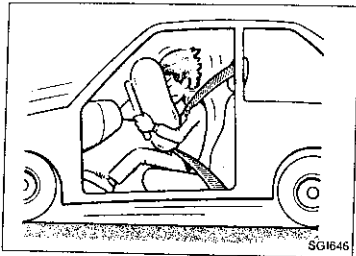

### Supplemental Restraint System "AIR BAG" and "SEAT BELT PRE-TENSIONER"

The Supplemental Restraint System "Air Bag" and "Seat Belt Pre-tensioner", used along with a seat belt, help to reduce the risk or severity of injury to the driver and front passenger in a frontal collision. The Supplemental Restraint System consists of air bag modules (located in the center of the steering wheel and on the instrument panel on the passenger side), seat belt pre-tensioners, a diagnostic sensor unit, warning lamp, wiring harness and spiral cable. Information necessary to service the system safely is included in the RS section of this Service Manual.

#### WARNING:

- To avoid rendering the SRS inoperative, which could increase the risk of personal injury or death in the event of a collision which would result in air bag inflation, all maintenance must be performed by an authorized NISSAN dealer.
- Improper maintenance, including incorrect removal and installation of the SRS, can lead to personal injury caused by unintentional activation of the system.
- All SRS electrical wiring harnesses and connectors are covered with yellow outer insulation. Do not use electrical test equipment on any circuit related to the SRS SYSTEM.

## HARNESS CONNECTOR

### Description

#### HARNESS CONNECTOR

- All harness connectors have been modified to prevent accidental looseness or disconnection.
- The connector can be disconnected by pushing or lifting the locking section.

#### CAUTION:

Do not pull the harness when disconnecting the connector.

[Example]

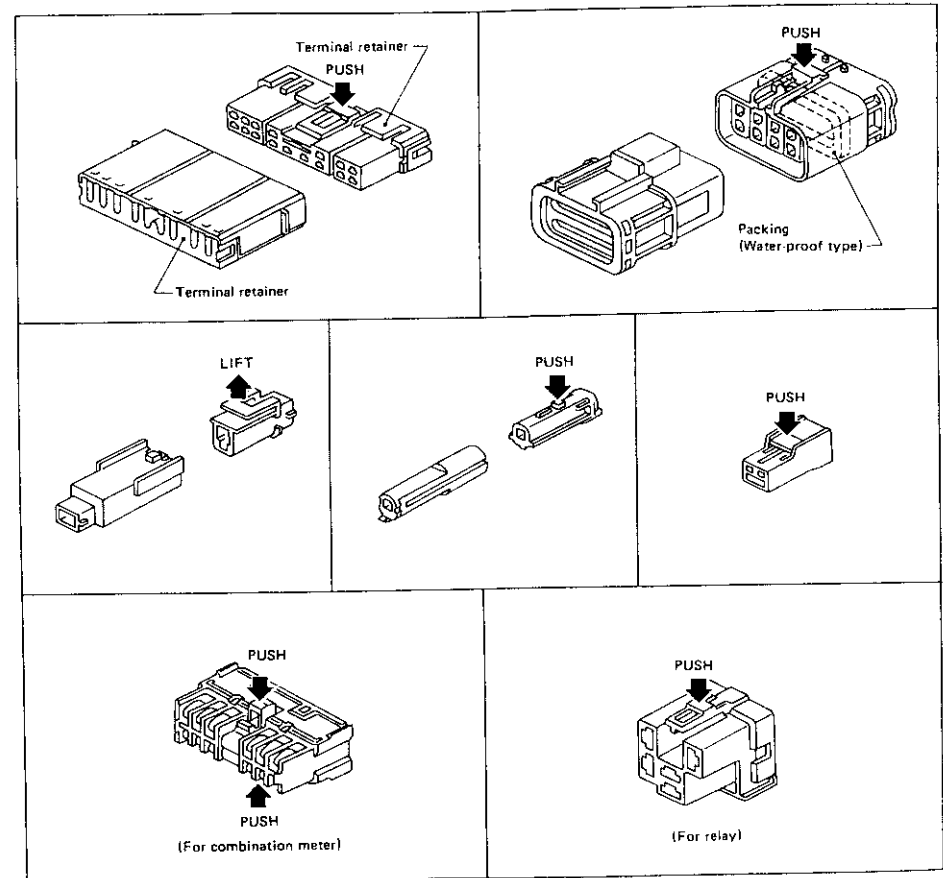

## STANDARDIZED RELAY

### Description

#### NORMAL OPEN, NORMAL CLOSED AND MIXED TYPE RELAYS

Relays can mainly be divided into three types: normal open, normal closed and mixed type relays.

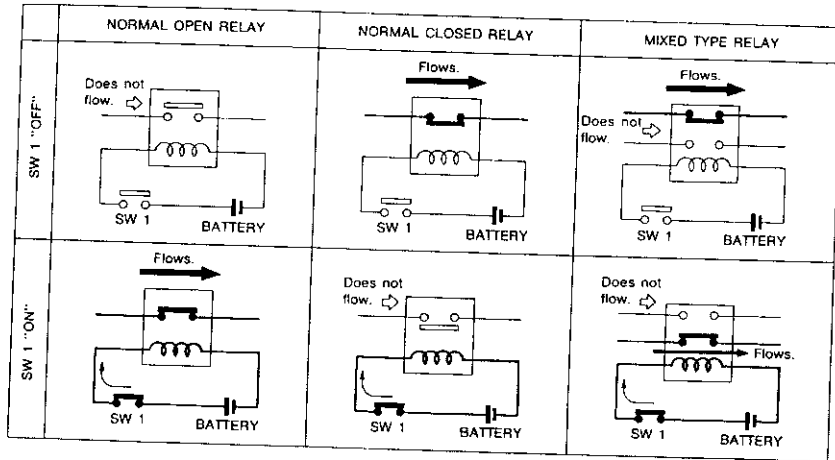

SEL881H

#### TYPE OF STANDARDIZED RELAYS

1M ..... 1 Make      2M ..... 2 Make  
 1T ..... 1 Transfer      1M-1B ..... 1 Make 1 Break

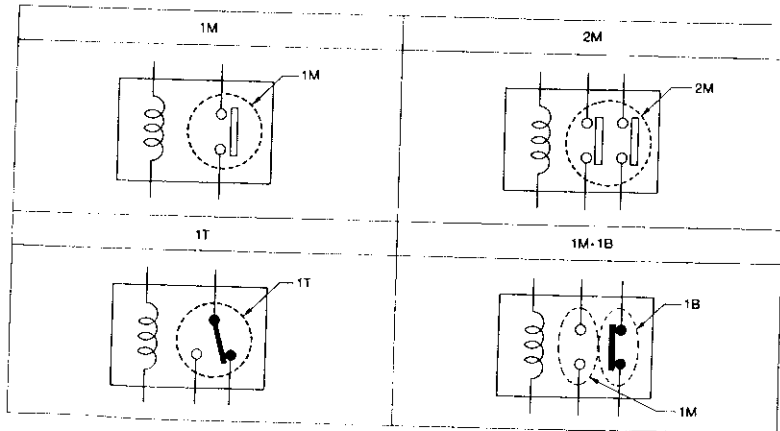

SEL882H

## STANDARDIZED RELAY

### Description (Cont'd)

Type	Outer view	Circuit	Connector symbol and connection	Case color
1T				BLACK
1M				BLUE or GREEN
2M				BROWN
1M-1B				GRAY
1M				BLUE

The arrangement of terminal numbers on the actual relays may differ from those shown above.

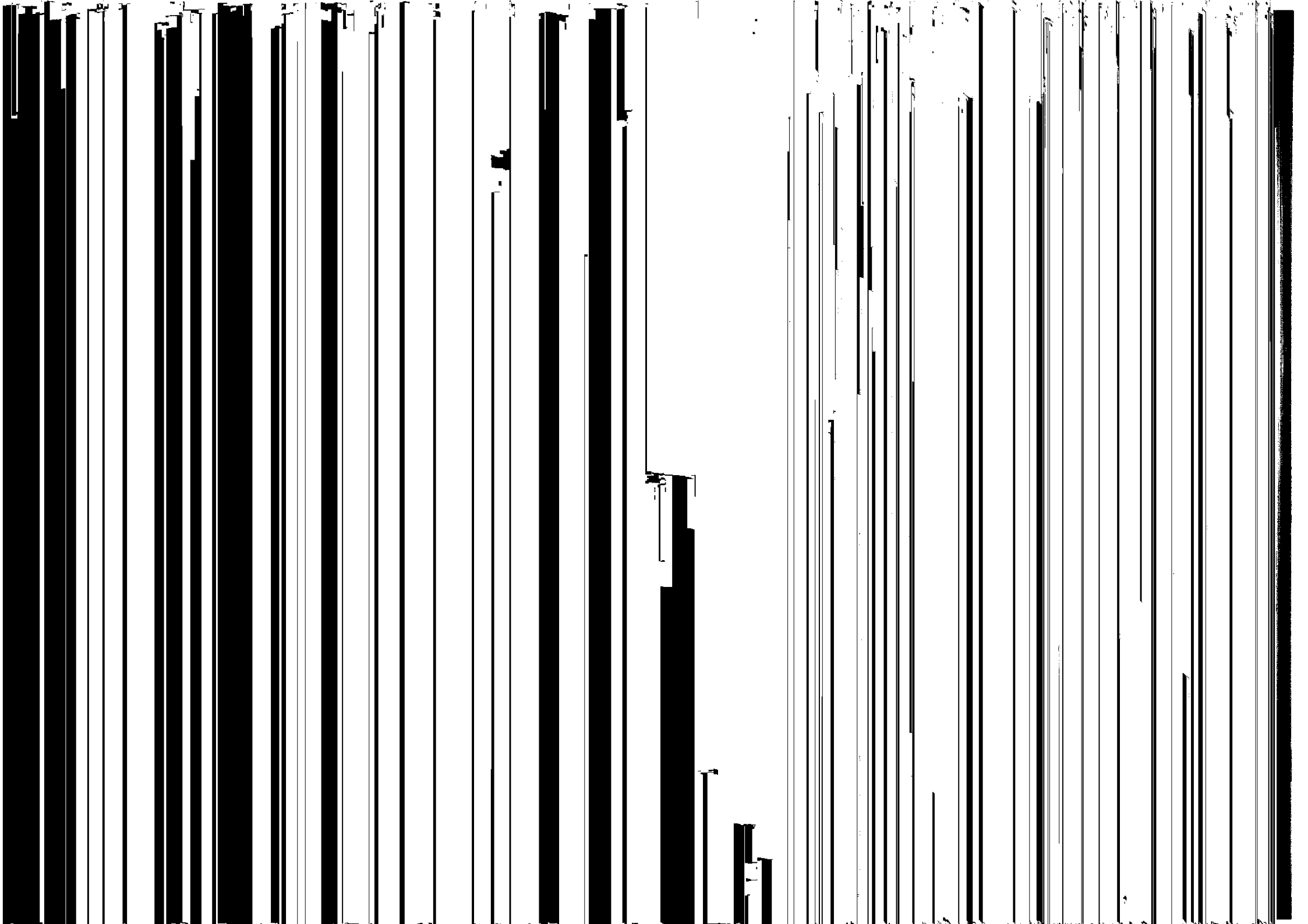

POWER SUPPLY ROUTING

Wiring Diagram — POWER —

EL-POWER-01

- (L) : LHD models
- (R) : RHD models
- (EU) : For Europe
- (EE) : Except for Europe
- (EL) : LHD models without daytime light system
- (NE) : Except (EL)
- \*1... (L) W/R, (R) W/L

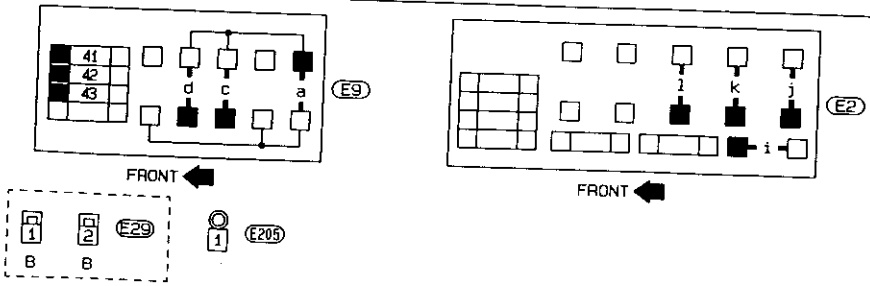
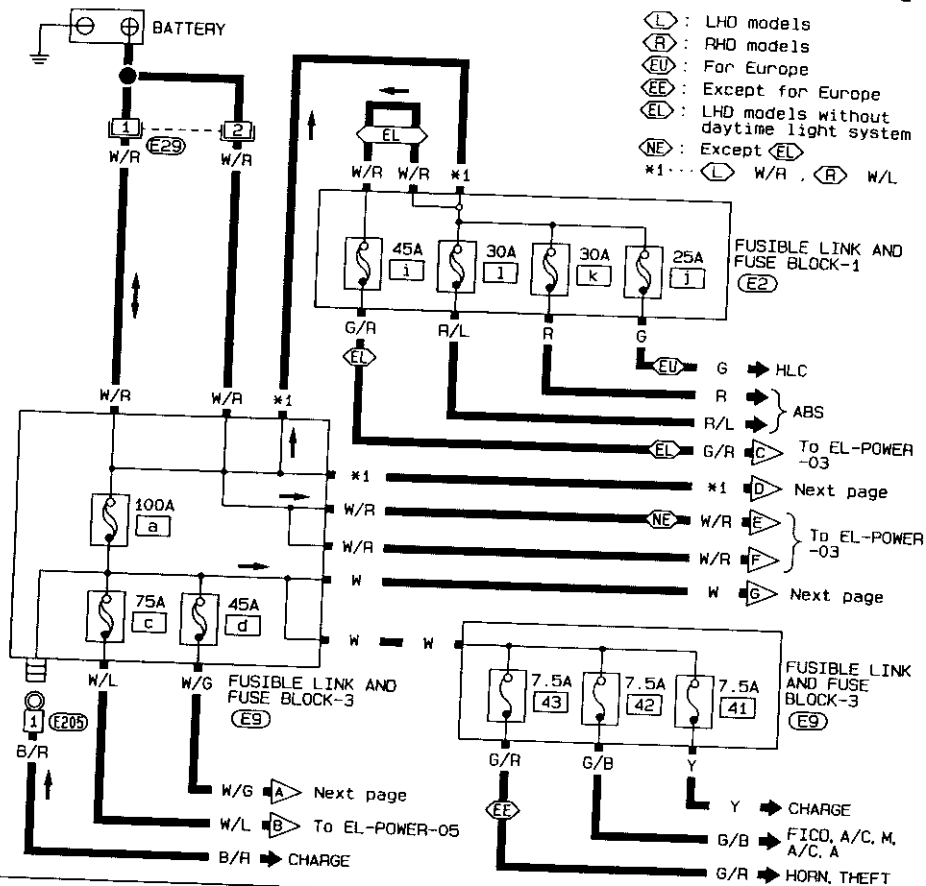

POWER SUPPLY ROUTING

Wiring Diagram — POWER — (Cont'd)

EL-POWER-02

- (L) : LHD models
- (R) : RHD models
- (EU) : For Europe
- \*1... (L) W/R, (R) W/L
- \*2... (L) L/R, (R) W
- \*3... (L) 27, (R) 29

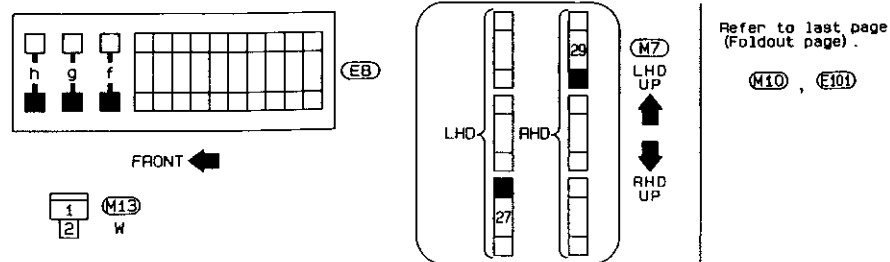
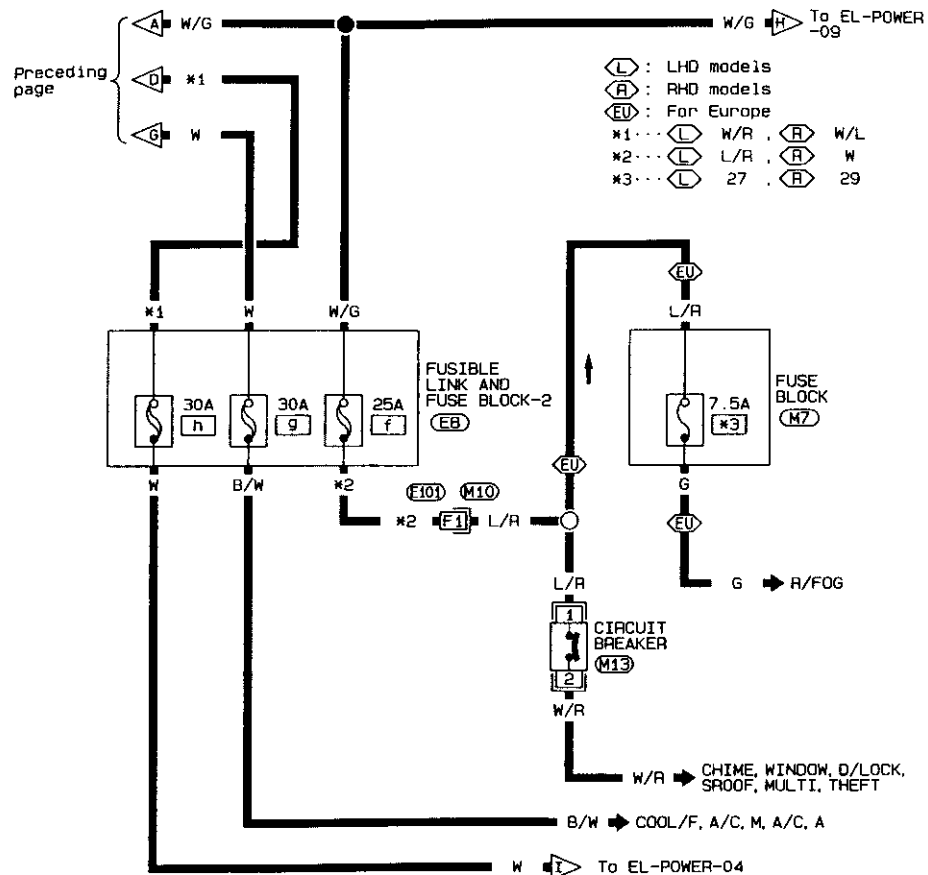

Refer to last page (Foldout page).

(M10), (E10)

POWER SUPPLY ROUTING

Wiring Diagram — POWER — (Cont'd)

EL-POWER-03

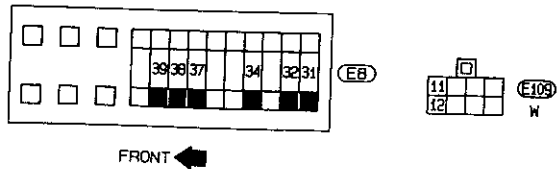
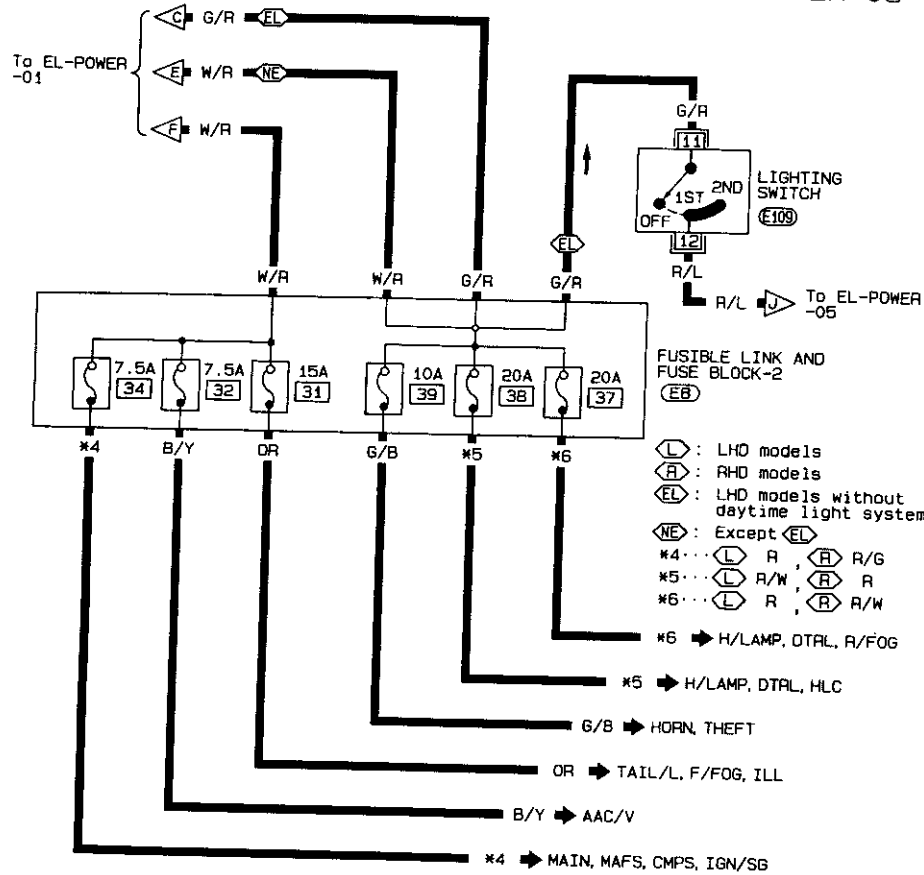

EL-12

SEL6701

POWER SUPPLY ROUTING

Wiring Diagram — POWER — (Cont'd)

EL-POWER-04

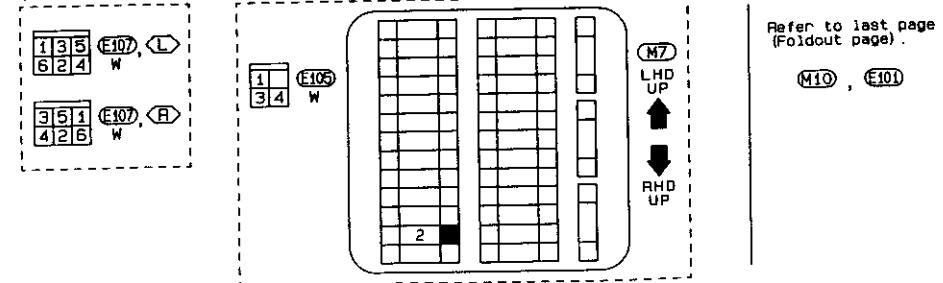
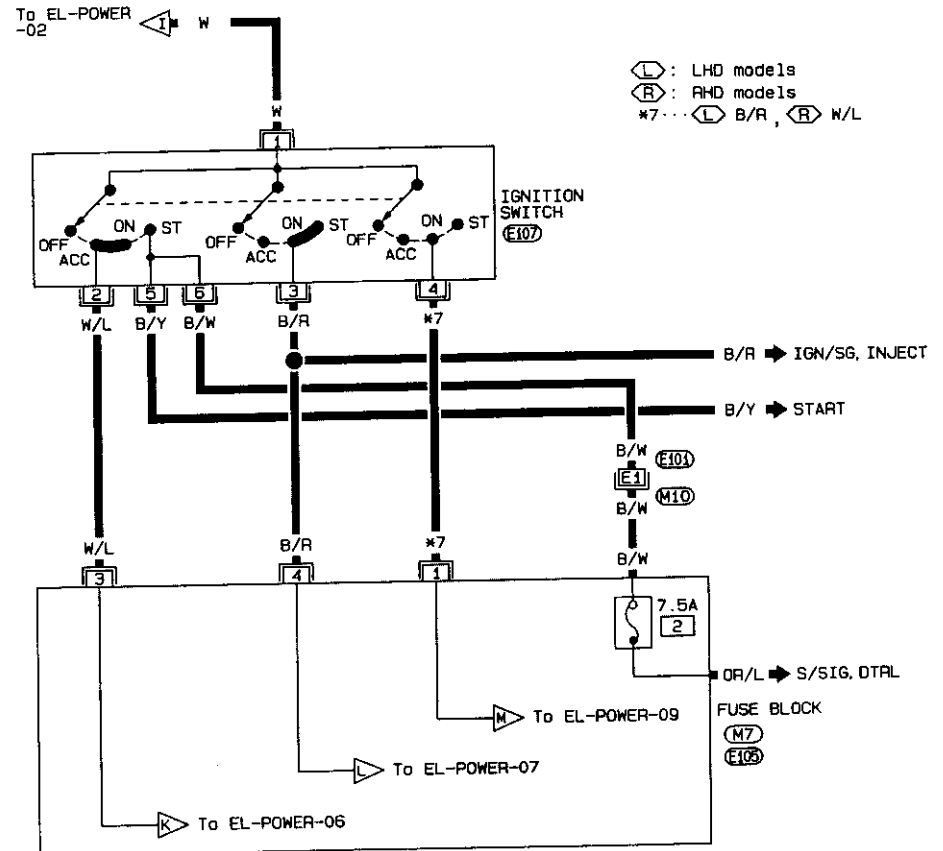

EL-13

SEL671T

POWER SUPPLY ROUTING

Wiring Diagram — POWER — (Cont'd)

EL-POWER-05

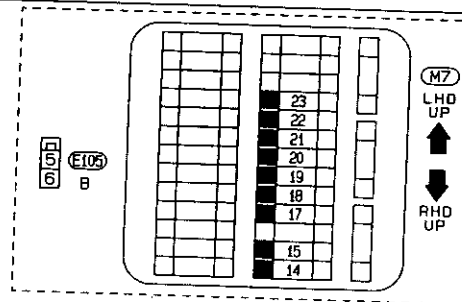
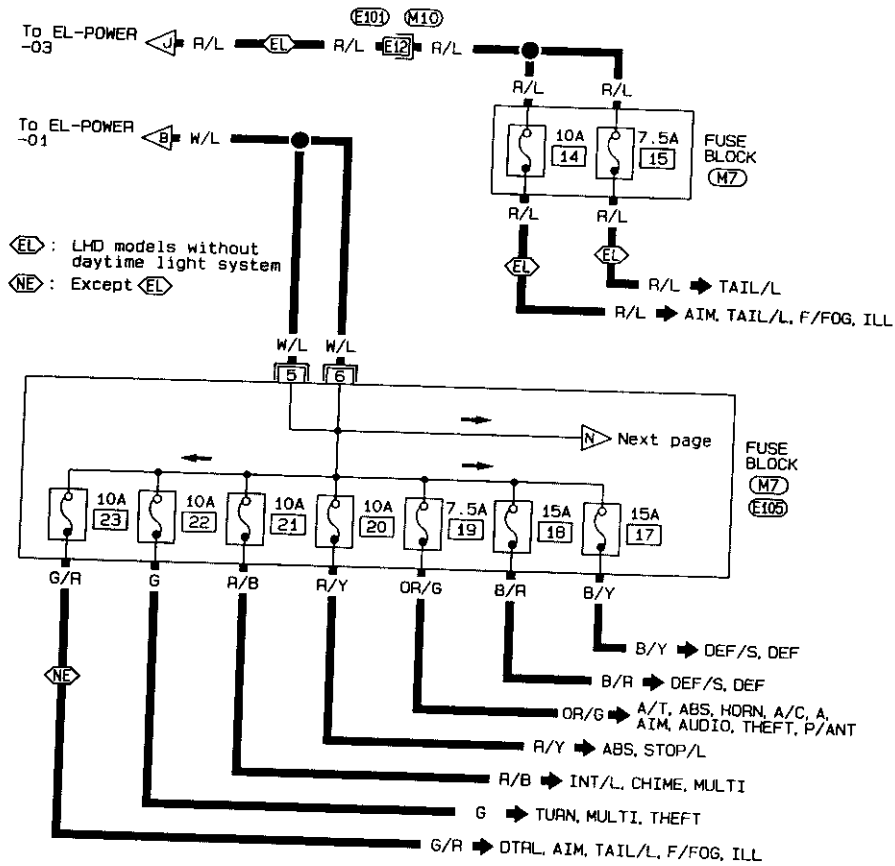

EL-14

SEL672T

POWER SUPPLY ROUTING

Wiring Diagram — POWER — (Cont'd)

EL-POWER-06

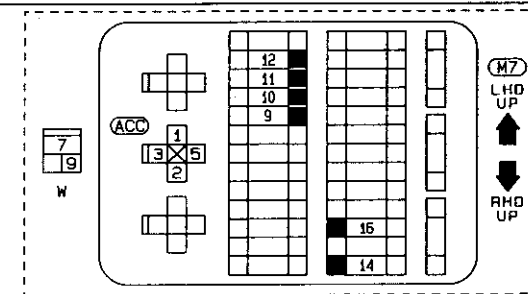
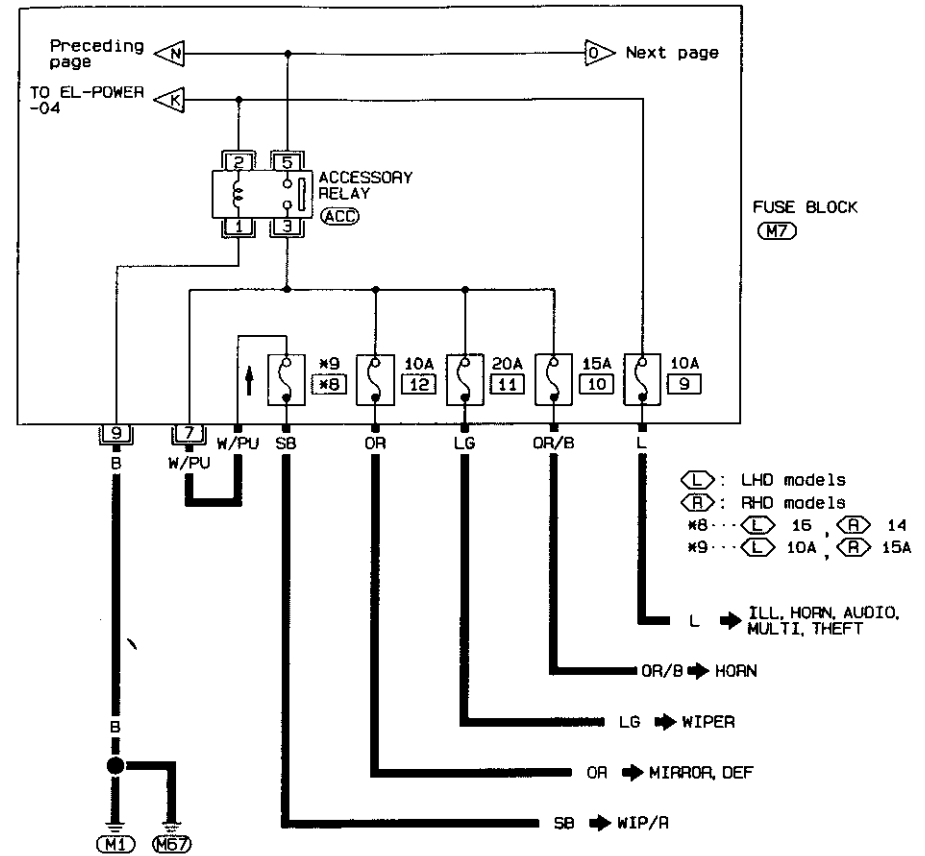

EL-15

SEL673T

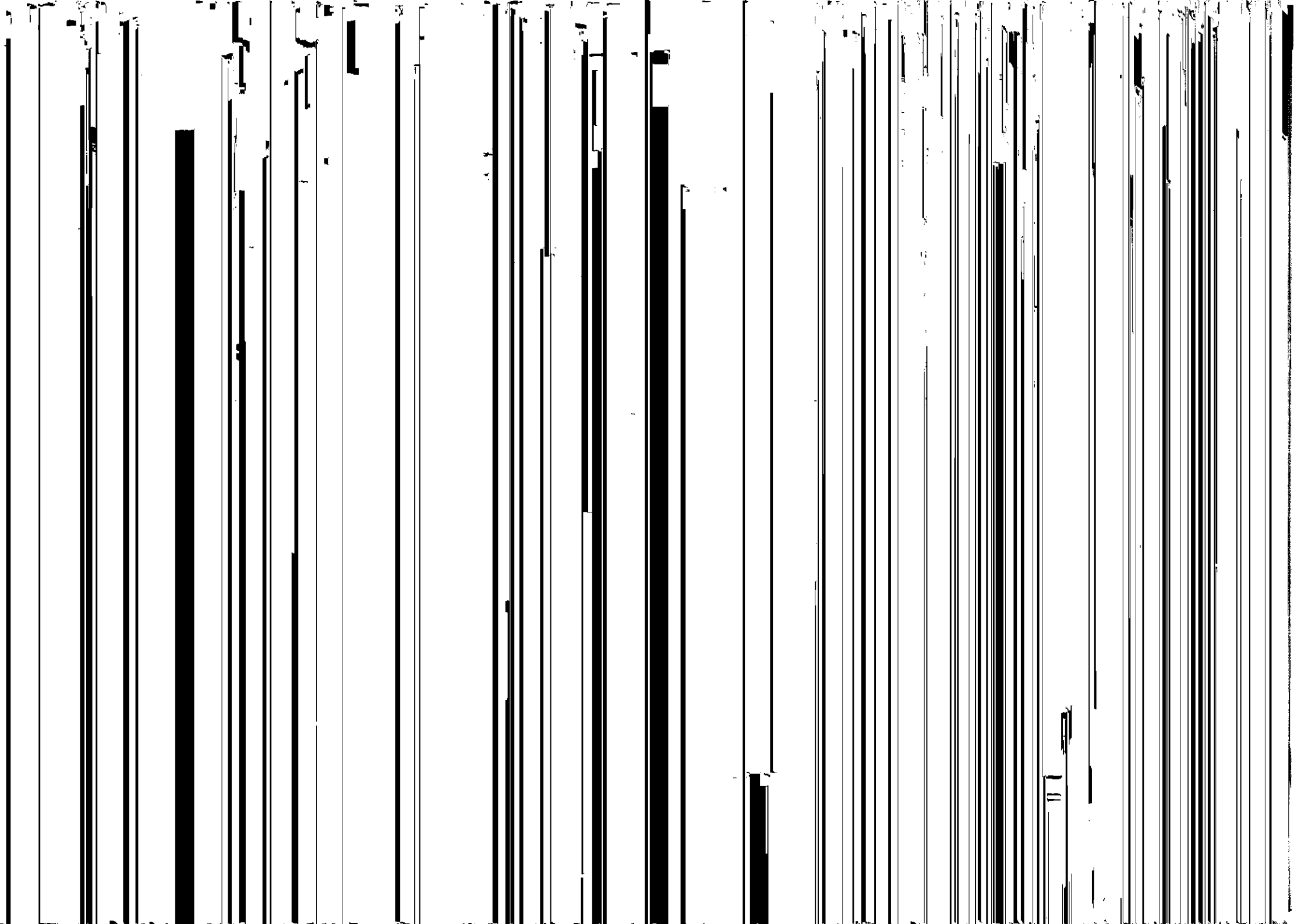



# POWER SUPPLY ROUTING

## Wiring Diagram — POWER — (Cont'd)

EL-POWER-09

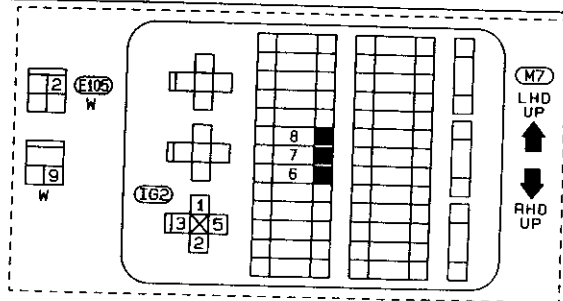
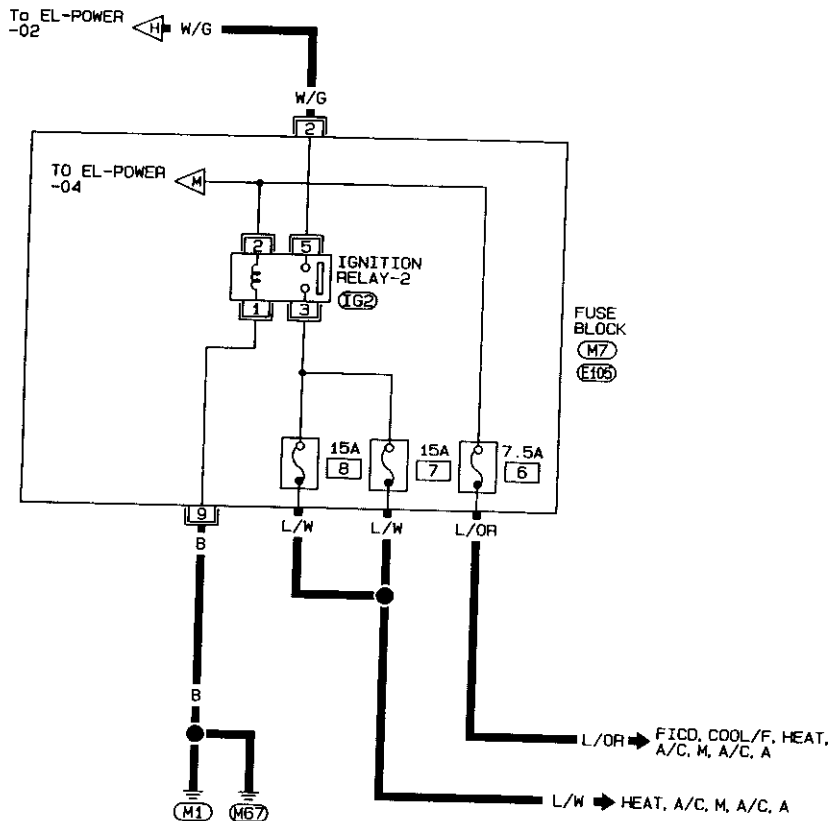

# POWER SUPPLY ROUTING

## Fuse

- If fuse is blown, be sure to eliminate cause of problem before installing new fuse.
- Use fuse of specified rating. Never use fuse of more than specified rating.
- Do not partially install fuse; always insert it into fuse holder properly.
- Remove fuse for clock if vehicle is not used for a long period of time.

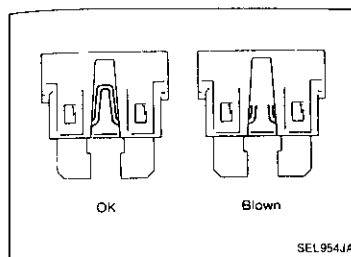

## Fusible Link

A melted fusible link can be detected either by visual inspection or by feeling with finger tip. If its condition is questionable, use circuit tester or test lamp.

### CAUTION:

- If fusible link should melt, it is possible that critical circuit (power supply or large current carrying circuit) is shorted. In such a case, carefully check and eliminate cause of problem.
- Never wrap outside of fusible link with vinyl tape. Important: Never let fusible link touch any other wiring harness, vinyl or rubber parts.

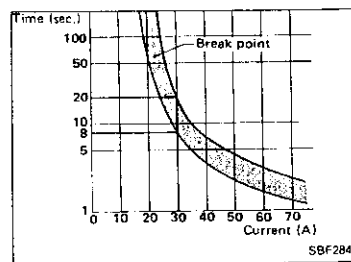
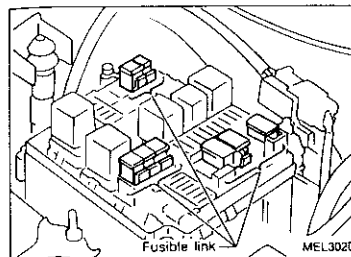

## Circuit Breaker

For example, when current is 30A, the circuit is broken within 8 to 20 seconds.

Circuit breakers are used in the following systems.

- Power window
- Power door lock
- Power sun roof
- Multi-remote control
- Theft warning
- Warning buzzer
- Rear window defogger and mirror defogger

## BATTERY

### CAUTION:

- If it becomes necessary to start the engine with a booster battery and jumper cables, use a 12-volt booster battery.
- After connecting battery cables, ensure that they are tightly clamped to battery terminals for good contact.
- Never add distilled water through the hole used to check specific gravity.

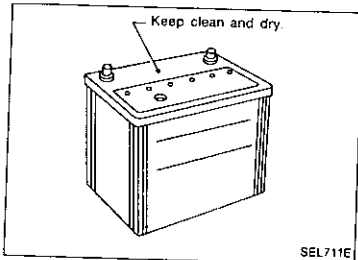

SEL711E

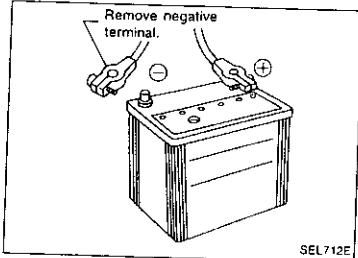

SEL712E

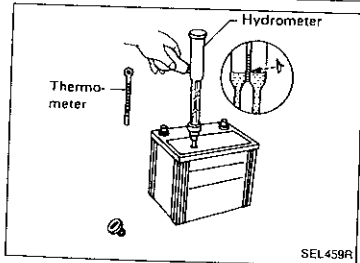

SEL459R

### How to Handle Battery

#### METHODS OF PREVENTING OVER-DISCHARGE

The following precautions must be taken to prevent over-discharging a battery.

- The battery surface (particularly its top) should always be kept clean and dry.
- The terminal connections should be clean and tight.
- At every routine maintenance, check the electrolyte level.
- When the vehicle is not going to be used over a long period of time, disconnect the negative battery terminal. (If the vehicle has an extended storage switch, turn it off.)

- Check the charge condition of the battery. Periodically check the specific gravity of the electrolyte. Keep a close check on charge condition to prevent over-discharge.

#### CHECKING ELECTROLYTE LEVEL

##### WARNING:

Do not allow battery fluid to come in contact with skin, eyes, fabrics, or painted surfaces. After touching a battery, do not touch or rub your eyes until you have thoroughly washed your hands. If the acid contacts the eyes, skin or clothing, immediately flush with water for 15 minutes and seek medical attention.

## BATTERY

### How to Handle Battery (Cont'd)

- Remove the cell plug using a suitable tool.
- Add distilled water up to the MAX level.

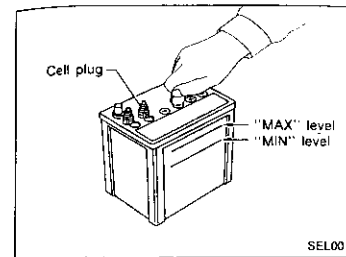

SEL001K

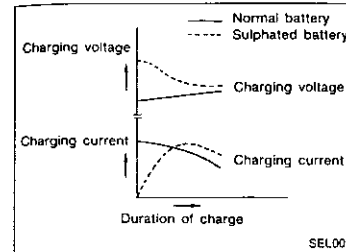

SEL005Z

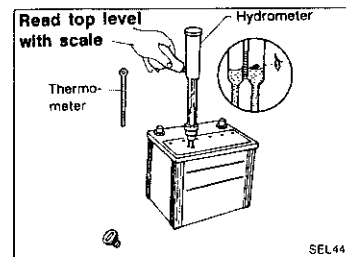

SEL442D

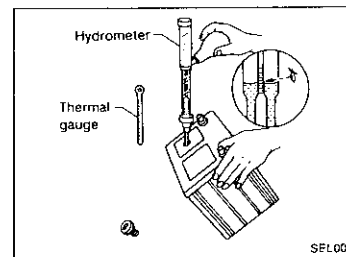

SEL006Z

### SULPHATION

A battery will be completely discharged if it is left unattended for a long time and the specific gravity becomes less than 1.100. This may result in sulphation on the cell plates.

To find if a discharged battery has been sulphated, pay attention to its voltage and current when charging it.

As shown in the figure at left, if the battery has been "sulphated", less current and higher voltage may be observed in the initial stage of charging.

### SPECIFIC GRAVITY CHECK

1. Read hydrometer and thermometer indications at eye level.
- When electrolyte level is too low, tilt battery case to raise it for easy measurement.

## BATTERY

### How to Handle Battery (Cont'd)

2. Convert into specific gravity at 20°C (68°F).  
Example:

- When electrolyte temperature is 35°C (95°F) and specific gravity of electrolyte is 1.230, converted specific gravity at 20°C (68°F) is 1.240.
- When electrolyte temperature is 0°C (32°F) and specific gravity of electrolyte is 1.210, converted specific gravity at 20°C (68°F) is 1.196.

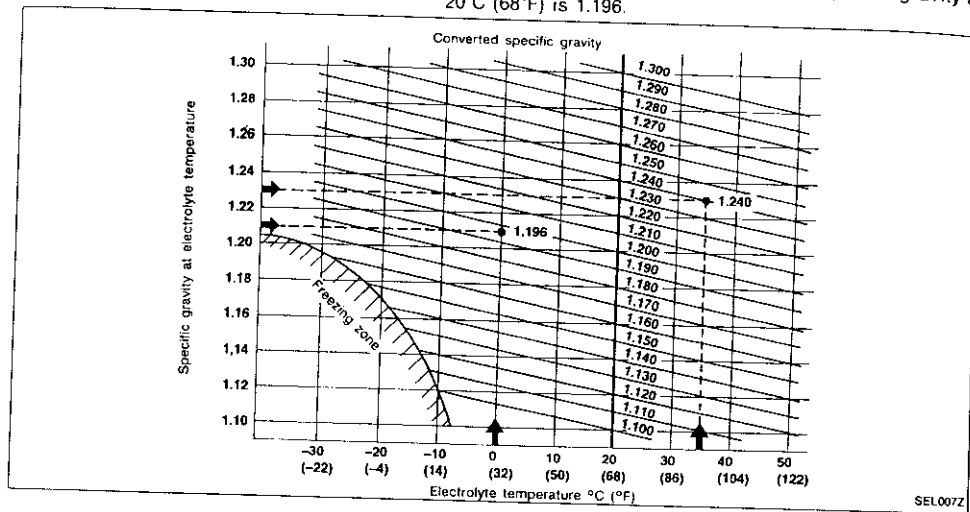

SEL007Z

## BATTERY

### Battery Test and Charging Chart

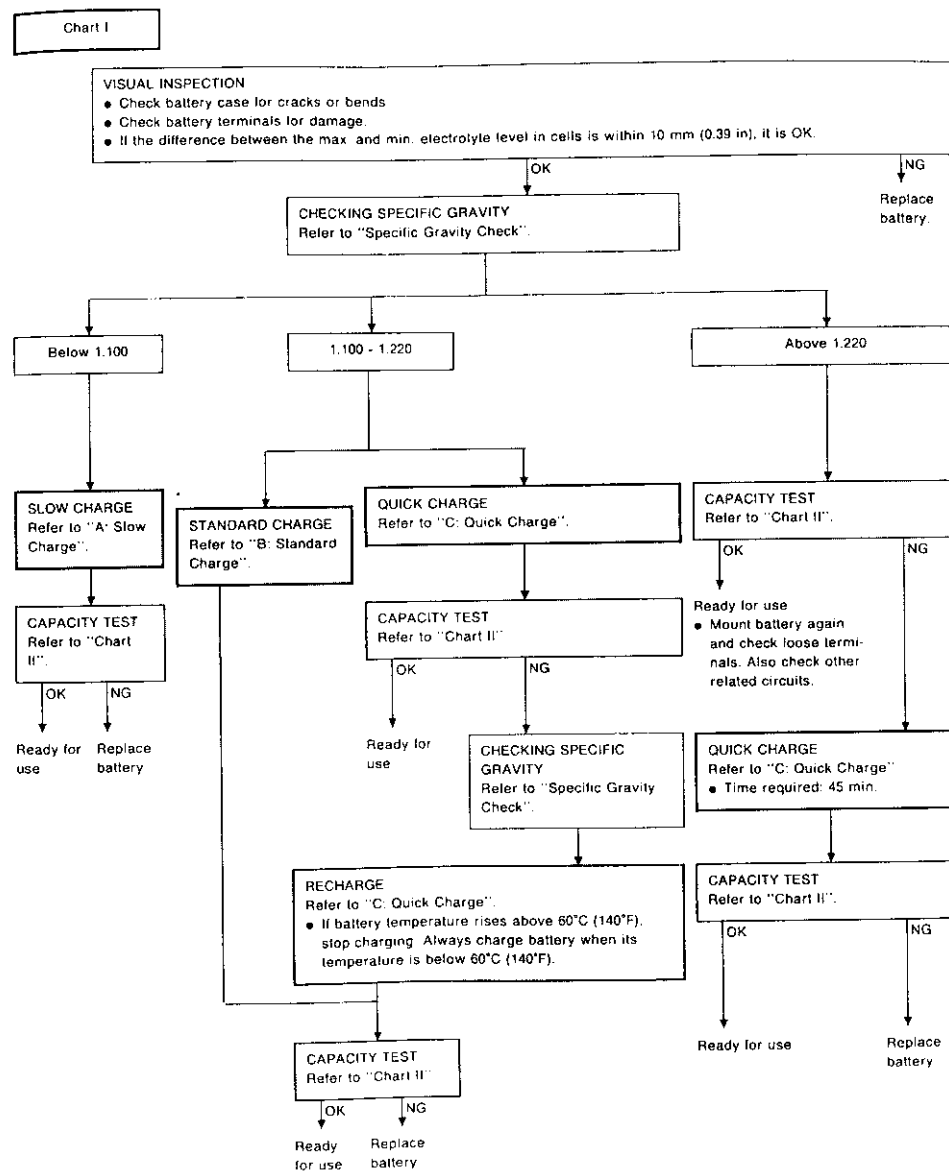

\* "STANDARD CHARGE" is recommended if the vehicle is in storage after charging.

## BATTERY

### Battery Test and Charging Chart (Cont'd)

- Check battery type and determine the specified current using the following table.

Fig 1 DISCHARGING CURRENT  
(Load Tester)

Type	Current (A)
28B19R(L)	90
34B19R(L)	99
46B24R(L)	135
55B24R(L)	135
50D23R(L)	150
56D23R(L)	180
65D26R(L)	195
80D26R(L)	195
75D31R(L)	210
95D31R(L)	240
115D31R(L)	240
95E41R(L)	300
130E41R(L)	330

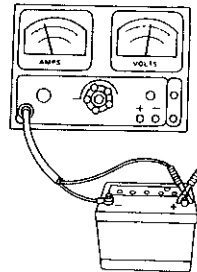

SEL0082

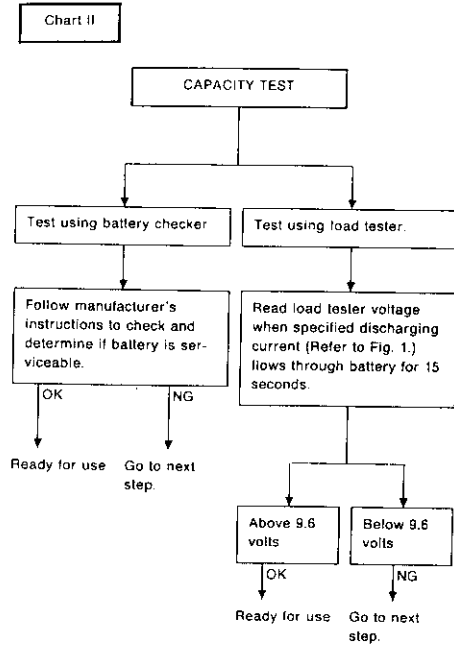

## BATTERY

### Battery Test and Charging Chart (Cont'd)

#### A. SLOW CHARGE

Determine initial charging current from specific gravity referring to Fig. 2.

- Charge battery.
- Check charging voltage 30 minutes after starting the battery charge.

12 to 15 volts

Below 12 volts or above 15 volts

Continue to charge for 12 hours.

Replace battery.

CHECKING SPECIFIC GRAVITY  
Refer to "Specific Gravity Check".

Conduct additional charge as per Fig. 3, if necessary.

Go to "CAPACITY TEST".

Fig. 2 INITIAL CHARGING CURRENT SETTING (Slow charge)

CONVERTED SPECIFIC GRAVITY	BATTERY TYPE												
	28B19R(L)	34B19R(L)	46B24R(L)	55B24R(L)	50D23R(L)	56D23R(L)	65D26R(L)	80D26R(L)	75D31R(L)	95D31R(L)	115D31R(L)	95E41R(L)	130E41R(L)
Below 1.100	4.0 (A)	5.0 (A)	7.0 (A)	8.0 (A)	9.0 (A)	10.0 (A)	10.0 (A)	10.0 (A)	10.0 (A)	10.0 (A)	10.0 (A)	10.0 (A)	14.0 (A)

- Check battery type and determine the specified current using the table shown above.
- After starting charging, adjustment of charging current is not necessary.

Fig 3 ADDITIONAL CHARGE (Slow charge)

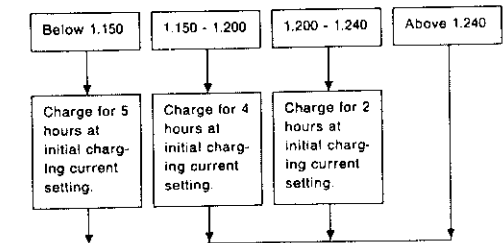

Go to "CAPACITY TEST"

#### CAUTION:

- Set charging current to value specified in Fig. 2. If charger is not capable of producing specified current value, set its charging current as close to that value as possible.
- Keep battery away from open flame while it is being charged.
- When connecting charger, connect leads first, then turn on charger. Do not turn on charger first, as this may cause a spark.
- If battery temperature rises above 60°C (140°F), stop charging. Always charge battery when its temperature is below 60°C (140°F).

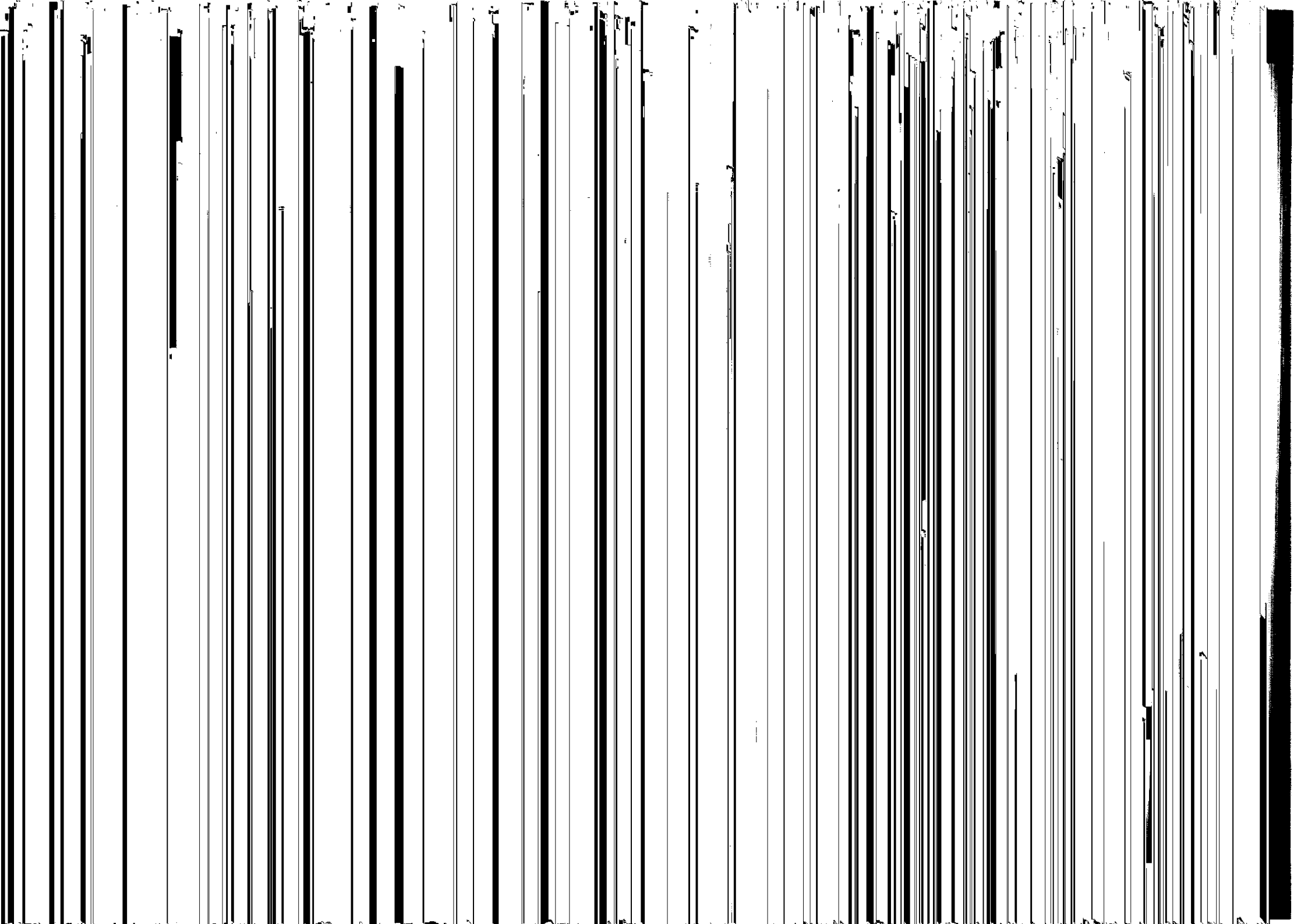

## STARTING SYSTEM

### System Description

①, located in the fusible link and fuse box).

②, located in the fuse block)

③, in the P or N position, power is supplied

④, terminal ② of the theft warning relay is grounded and power

⑤, when operating, power is supplied

⑥, terminal ④

⑦, for windings.

⑧, in the P or N position, power is supplied

⑨, after motor windings.

⑩, provides a closed circuit between the battery and the starter motor. When the engine block. With power and ground supplied, cranking occurs

⑪, located in the fusible link and fuse box).

⑫, located in the fuse block)

⑬, in the P or N position, power is supplied

⑭, terminal ② of the theft warning relay is grounded and power

⑮, when operating, power is supplied

⑯, terminal ④

⑰, ①, with the selector lever in the P or N position

⑱, for windings.

⑲, in the P or N position, power is supplied

⑳, ①, with the selector lever in the P or N position

㉑, provides a closed circuit between the battery and starter motor. When the engine block. With power and ground supplied, cranking occurs

## STARTING SYSTEM

### Wiring Diagram — START —

#### M/T MODELS

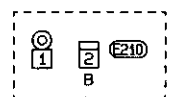
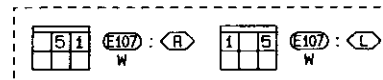
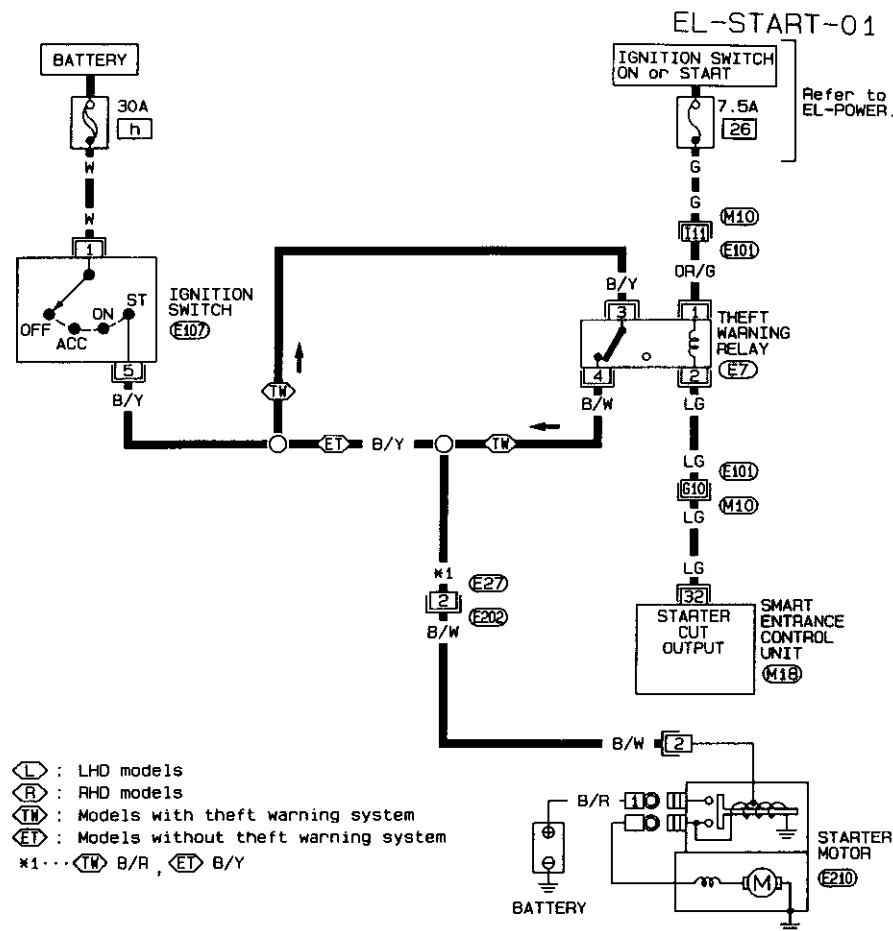

Refer to last page (foldout page):

- M10, E101
- M1B

# STARTING SYSTEM

## Wiring Diagram — START — (Cont'd)

A/T MODELS

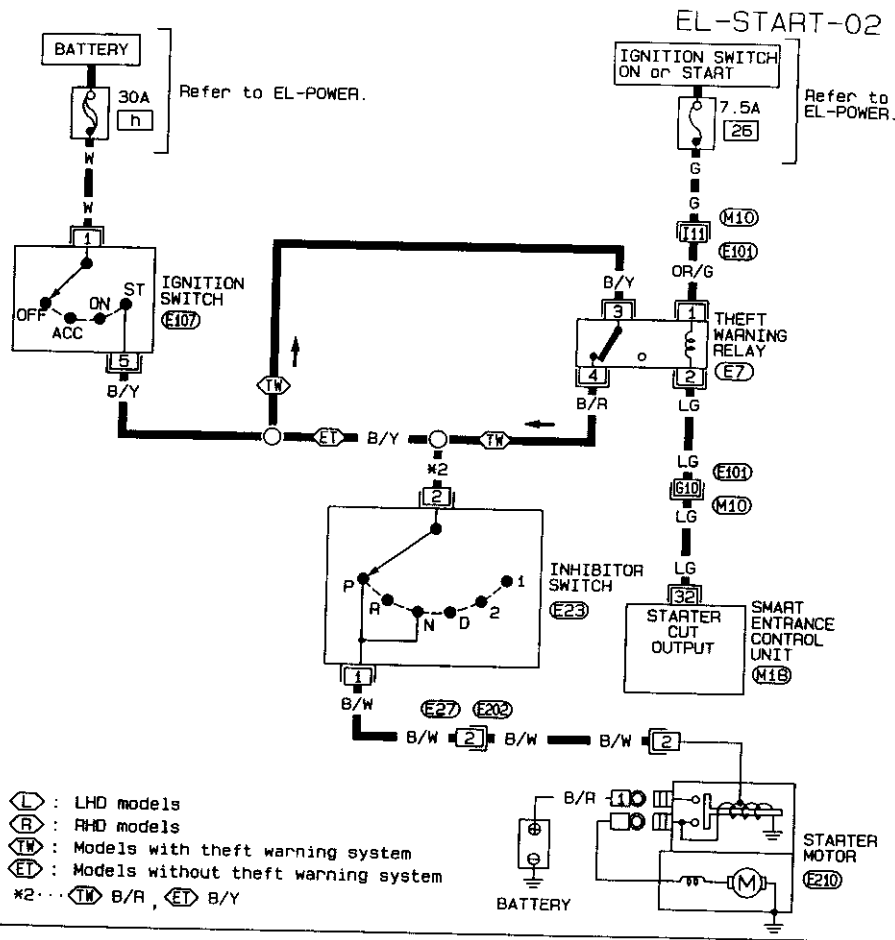

- Ⓛ : LHD models
- Ⓡ : RHD models
- ⓉⓂ : Models with theft warning system
- ⓔⓉ : Models without theft warning system
- \*2... ⓉⓂ B/R, ⓔⓉ B/Y

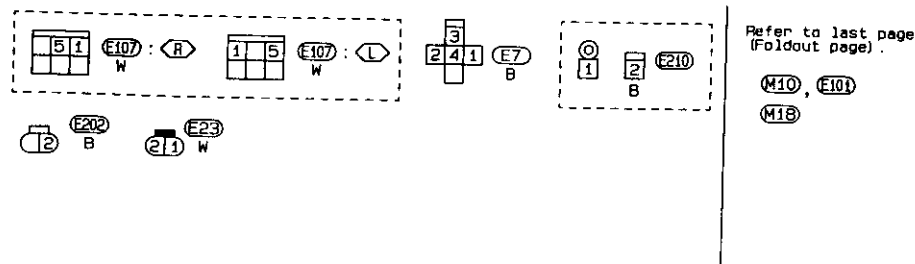

EL-30

SEL663T

# STARTING SYSTEM

## Trouble-shooting

If any abnormality is found, immediately disconnect battery negative terminal.

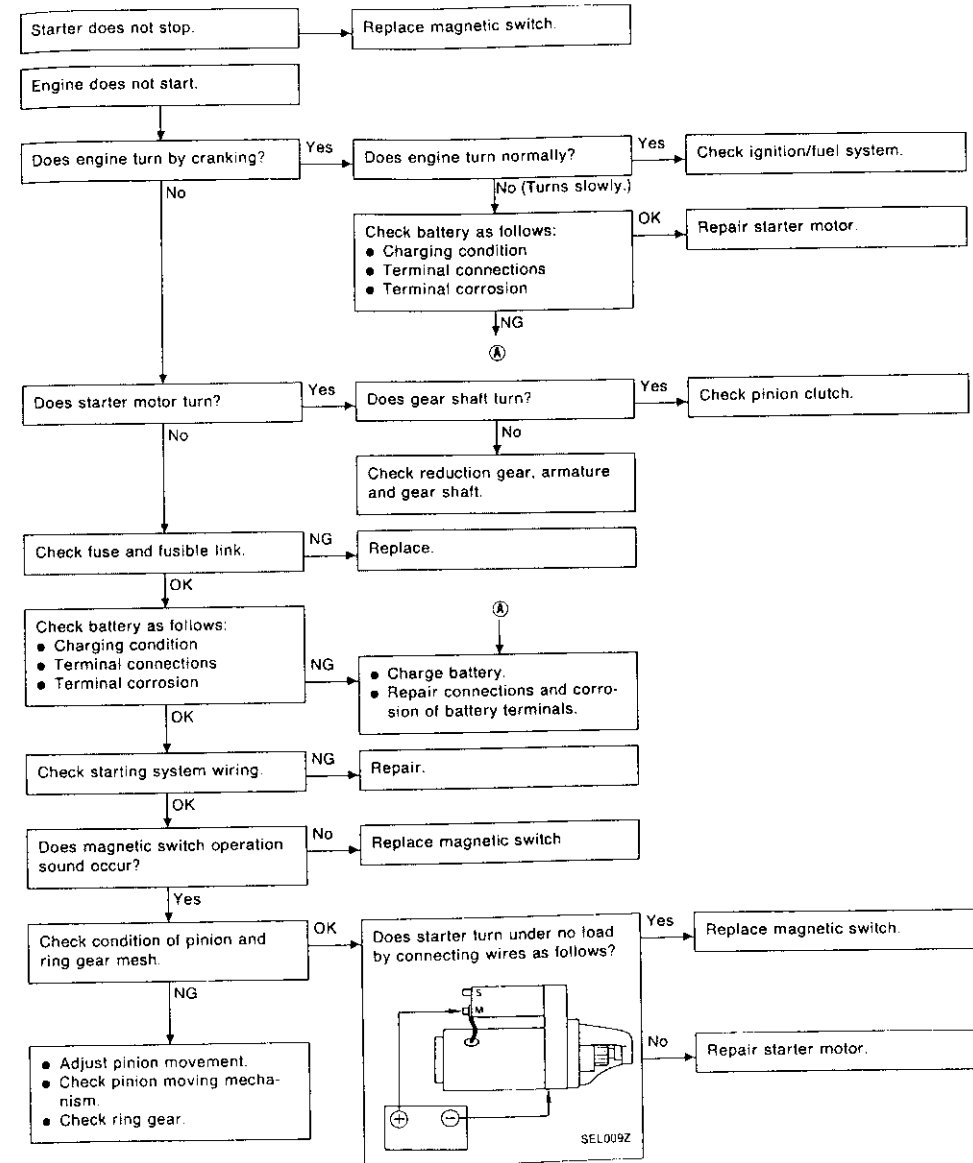

EL-31

EL

BOX





## 3 SYSTEM

### Check (Cont'd)

#### SPRING PRESSURE

Brush spring pressure with brush spring detached from

ing pressure (with new brush):

Refer to SDS. (EL-37)

Within the specified values ... Replace.

#### BRUSH HOLDER

Perform insulation test between brush holder (positive) and its base (negative side).

Continuity exists. ... Replace.

Move brush to see if it moves smoothly.

If holder is bent, replace it; if sliding surface is dirty,

#### Check

Secure magnet to yoke by bonding agent. Check magnet to

is secured to yoke and for any cracks. Replace

missing parts as an assembly.

It should move slightly as it is only inserted and not bonded.

Do not yoke in a vice or strike it with a hammer.

## STARTING SYSTEM

### Armature Check

1. Continuity test (between two segments side by side).
  - No continuity ... Replace.
2. Insulation test (between each commutator bar and shaft).
  - Continuity exists. ... Replace.

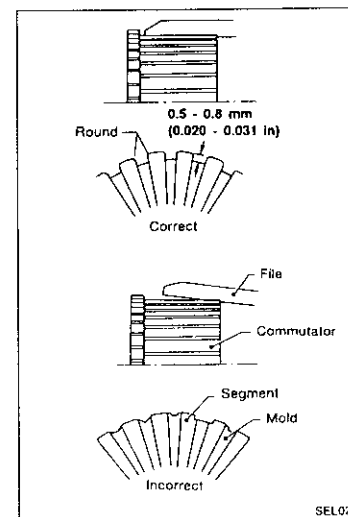
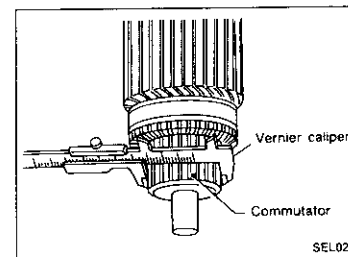
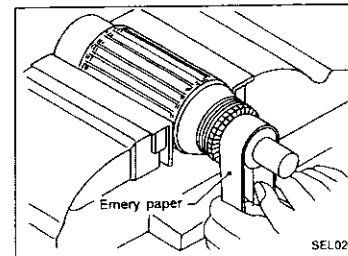
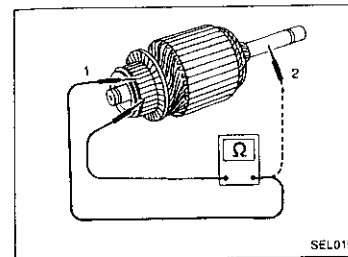

3. Check commutator surface.
  - Rough ... Sand lightly with No. 500 - 600 emery paper.

4. Check diameter of commutator.

**Commutator minimum diameter:**

**Refer to SDS. (EL-37)**

- Less than specified value ... Replace.

5. Check depth of insulating mold from commutator surface.

- Less than 0.2 mm (0.008 in) ... Undercut to 0.5 to 0.8 mm (0.020 to 0.031 in)

## STARTING SYSTEM

### Assembly

Apply high-temperature grease to lubricate the bearing, gears and frictional surface when assembling the starter. Carefully observe the following instructions.

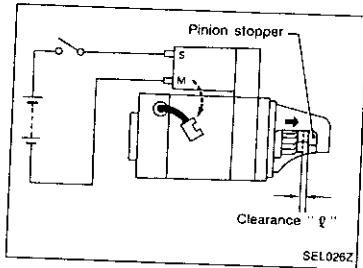

### PINION PROTRUSION LENGTH ADJUSTMENT

With pinion driven out by magnetic switch, push pinion back to remove slack and measure clearance "l" between the front edge of the pinion and the pinion stopper.

Clearance "l":

Refer to SDS. (EL-37)

- Not in the specified value ... Adjust by adjusting plate.

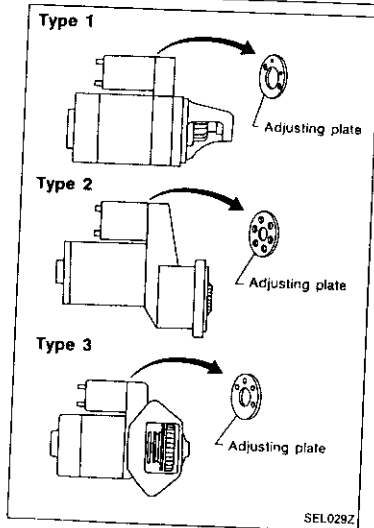

## STARTING SYSTEM

### Service Data and Specifications (SDS)

#### STARTER

Type	S114-705B		
	S114-705C		
	HITACHI make		
	Reduction gear		
System voltage	V	12	
No-load	Terminal voltage	V	11.0
	Current	A	Less than 90
	Revolution	rpm	More than 2,950
Minimum length of brush	mm (in)	11.0 (0.433)	
Brush spring tension (With new brush)	N (kg, lb)	17.6 - 21.6 (1.80 - 2.20, 3.96 - 4.86)	
Minimum diameter of commutator	mm (in)	32.0 (1.260)	
Clearance between pinion front edge and pinion stopper	mm (in)	0.3 - 1.5 (0.012 - 0.059)	
Clearance between bearing metal and armature shaft	mm (in)	Less than 0.2 (0.008)	

## CHARGING SYSTEM

### System Description

The alternator provides DC voltage to operate the vehicle's electrical system and to keep the battery charged. The voltage output is controlled by the IC regulator.

Power is supplied at all times to alternator terminal ⑤ through:

- 100A fusible link (letter **A**), located in the fusible link and fuse box), and
- 7.5A fuse (No. **41**), located in the fusible link and fuse box).

Terminal ⑥ supplies power to charge the battery and operate the vehicle's electrical system. Output voltage is controlled by the IC regulator at terminal ⑤ detecting the input voltage. The charging circuit is protected by the 100A fusible link.

Terminal ⑥ of the alternator supplies ground through body ground (E206).

With the ignition switch in the ON or START position, power is supplied

- through 7.5A fuse (No. **25**), located in the fuse block)
- to combination meter terminal ② for the charge warning lamp.

Ground is supplied to terminal ④ of the combination meter through terminal ① of the alternator. With power and ground supplied, the charge warning lamp will illuminate. When the alternator is providing sufficient voltage with the engine running, the ground is opened and the charge warning lamp will go off.

If the charge warning lamp illuminates with the engine running, a fault is indicated.

## CHARGING SYSTEM

### Wiring Diagram — CHARGE —

EL-CHARGE-01

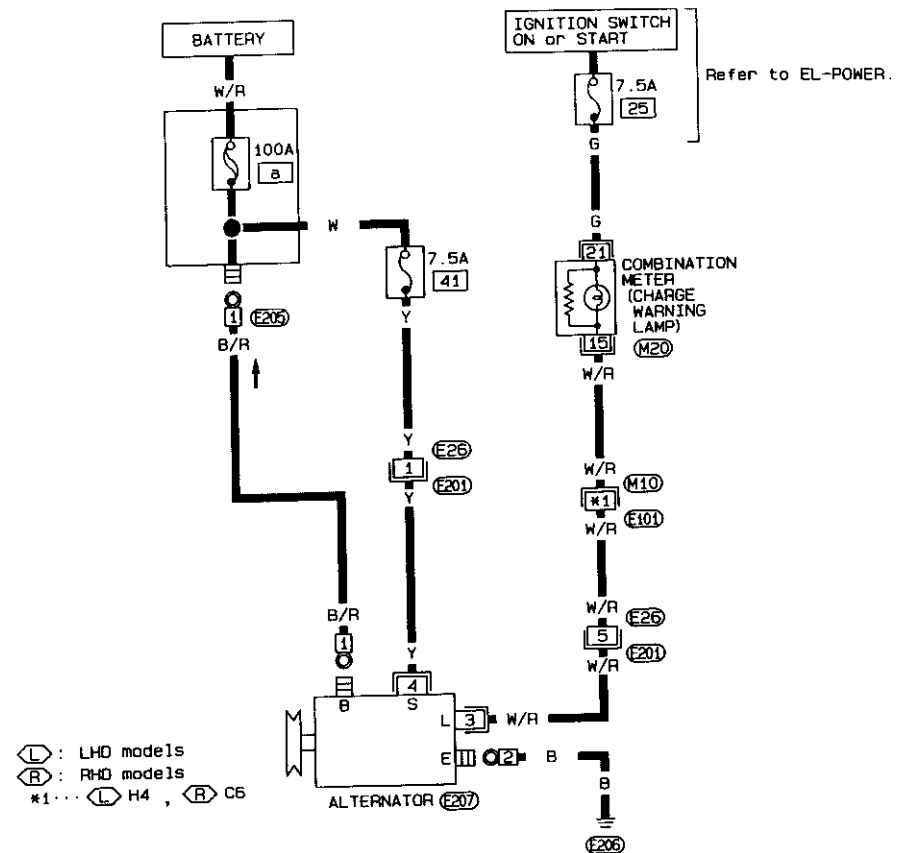

Ⓛ: LHD models  
 Ⓡ: RHD models  
 \*1... Ⓛ H4, Ⓡ C6

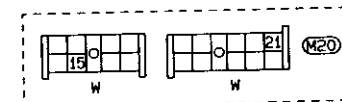
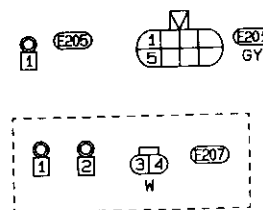

Refer to last page (Foldout page).

(M10, E101)

## CHARGING SYSTEM

### Trouble-shooting

Before conducting an alternator test, make sure that the battery is fully charged. A 30-volt voltmeter and suitable test probes are necessary for the test. The alternator can be checked easily by referring to the Inspection Table.

Before starting trouble-shooting, inspect the fusible link.

#### WITH IC REGULATOR

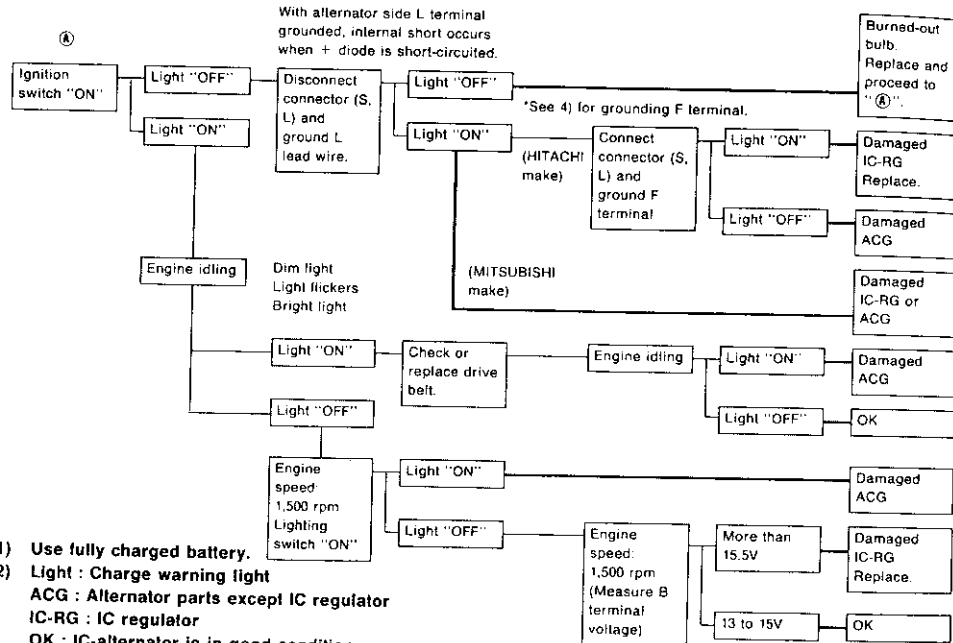

- 1) Use fully charged battery.
- 2) Light : Charge warning light  
ACG : Alternator parts except IC regulator  
IC-RG : IC regulator  
OK : IC-alternator is in good condition.
- 3) When reaching "Damaged ACG", remove alternator from vehicle and disassembly, inspect and correct or replace faulty parts.
- 4) \*Method of grounding F terminal (HITACHI make only)

#### Gasoline engine model

Contact tip of wire with brush and attach wire to alternator body.

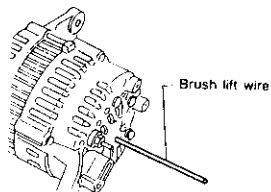

SEL030Z

- 5) Terminals "S", "L", "B" and "E" are marked on rear cover of alternator.

## CHARGING SYSTEM

### Construction

SEC. 231  
A2T82191

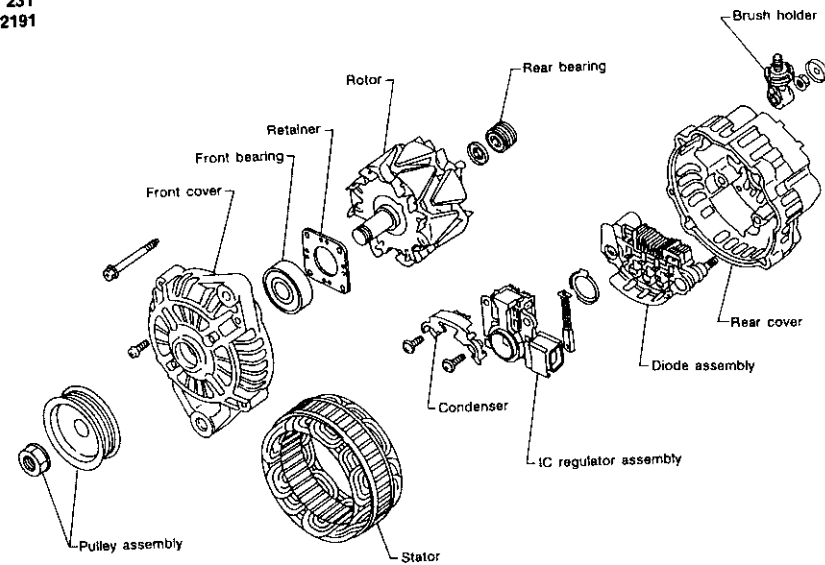

SEL666T

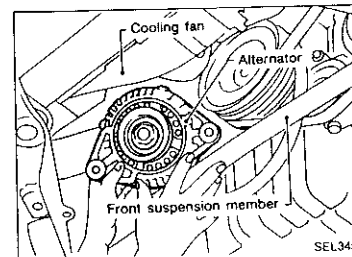

SEL345T

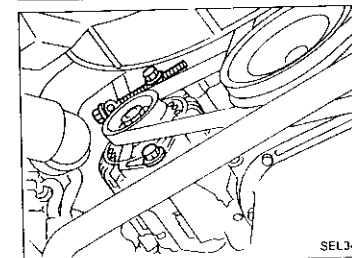

SEL346T

### Removal and Installation

#### REMOVAL

1. Remove engine undercover.
2. Remove stabilizer bracket.
3. Remove power steering tube mounting bracket.
4. Remove drive belt from alternator.
5. Disconnect harness connector.
6. Remove cooling fan lower shroud.
7. Remove alternator.

#### INSTALLATION

To install, reverse the removal procedure.

## CHARGING SYSTEM

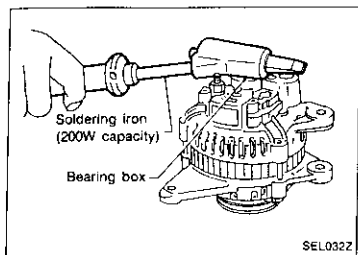

### Disassembly

#### REAR COVER REMOVAL

##### CAUTION:

Rear cover may be hard to remove because a ring is used to lock outer race of rear bearing. To facilitate removal of rear cover, heat just bearing box section with a 200W soldering iron.

Do not use a heat gun, as it can damage diode assembly.

#### REAR BEARING

##### CAUTION:

- Do not reuse rear bearing after removal. Replace with a new one.
- Do not lubricate rear bearing outer race.

### Rotor Check

#### 1. Resistance test

**Resistance: Refer to SDS. (EL-45)**

- Not within the specified values ... Replace rotor.

#### 2. Insulator test

- Continuity exists ... Replace rotor.

#### 3. Check slip ring for wear.

**Slip ring minimum outer diameter:**

**Refer to SDS. (EL-45)**

- Not within the specified values ... Replace rotor.

### Brush Check

#### 1. Check smooth movement of brush.

- Not smooth ... Check brush holder and clean.

#### 2. Check brush for wear.

- Replace brush if it is worn down to the limit line.

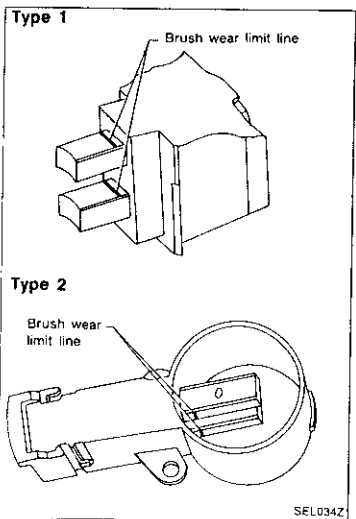
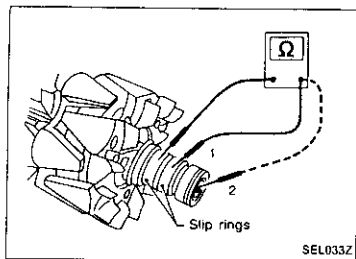

## CHARGING SYSTEM

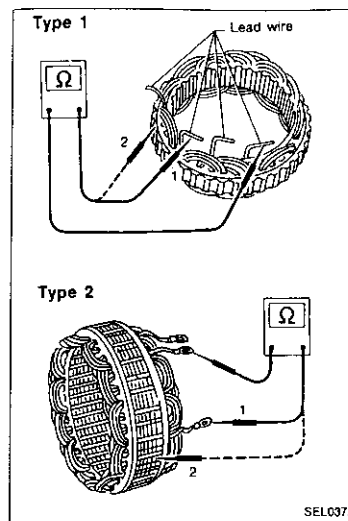

### Stator Check

#### 1. Continuity test

- No continuity ... Replace stator.

#### 2. Ground test

- Continuity exists ... Replace stator.

## CHARGING SYSTEM

### Diode Check

#### MAIN DIODES

- Use an ohmmeter to check condition of diodes as indicated in chart below.
- If any of the test results is not satisfactory, replace diode assembly.

	Ohmmeter probes		Judgement
	Positive ⊕	Negative ⊖	
Diodes check (Positive side)	Positive diode plate	Diode terminals	Diode conducts in only one direction.
	Diode terminals	Positive diode plate	
Diodes check (Negative side)	Negative diode plate	Diode terminals	Diode conducts in only one direction.
	Diode terminals	Negative diode plate	

Type 1

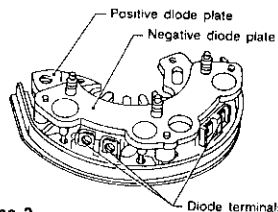

Type 2

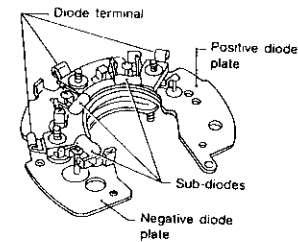

Type 3

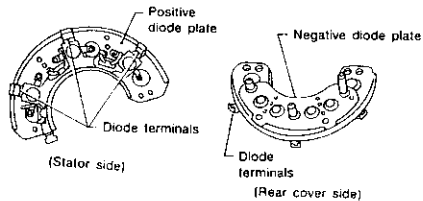

Type 4

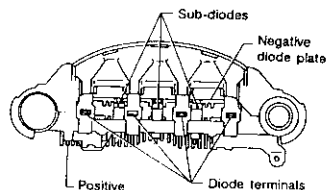

Type 5

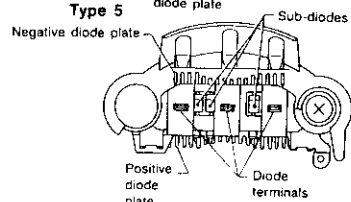

Type 6

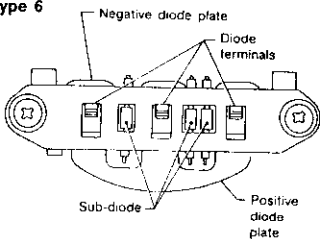

SEL039Z

## CHARGING SYSTEM

### Assembly

#### RING FITTING IN REAR BEARING

- Fix ring into groove in rear bearing so that it is as close to the adjacent area as possible.

#### CAUTION:

Do not reuse rear bearing after removal.

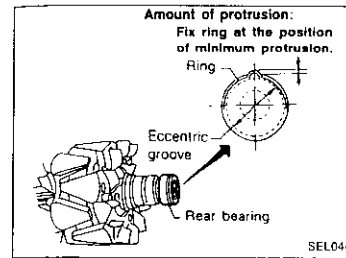

SEL044Z

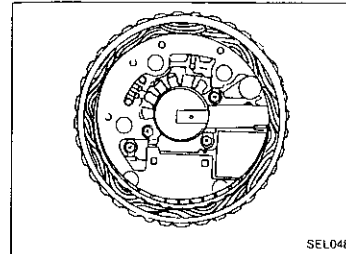

SEL048Z

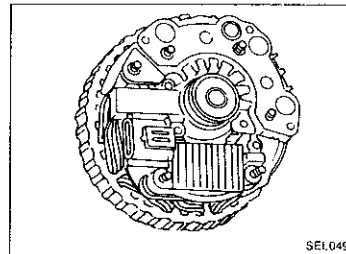

SEL049Z

#### REAR COVER INSTALLATION

- (1) Fit brush assembly, diode assembly, regulator assembly and stator.
- (2) Push brushes up with fingers and install them to rotor. Take care not to damage slip ring sliding surface.

### Service Data and Specifications (SDS)

#### ALTERNATOR

Type	A2T82191	
	MITSUBISHI make	
Nominal rating	V-A	12-90
Ground polarity	Negative	
Minimum revolution under no-load (when 13.5 volts is applied)	rpm	Less than 1,300
Hot output current	A/rpm	More than 22/1,300 More than 67/2,500 More than 90/5,000
Regulated output voltage	V	14.1 - 14.7
Minimum length of brush	mm (in)	More than 5 (0.20)
Slip ring minimum outer diameter	mm (in)	More than 22.1 (0.870)
Rotor (field coil) resistance	Ω	2.5

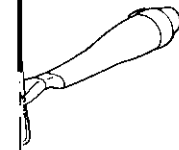
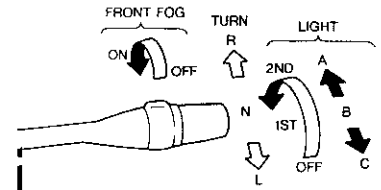

REAR WIPER AND WASHER SWITCH

	WASH	OFF	INT	ON	WASH
21			○		
22				○	
23	○				○
24	○		○	○	○

HORN SWITCH (Models without air bag system)

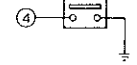

GI  
WA  
EM  
LC  
EC  
FE  
CL  
WT  
AT  
PD  
FA  
RA  
BR  
ST  
RS  
BT  
HA  
EL  
DX

## HEADLAMP

### Replacement

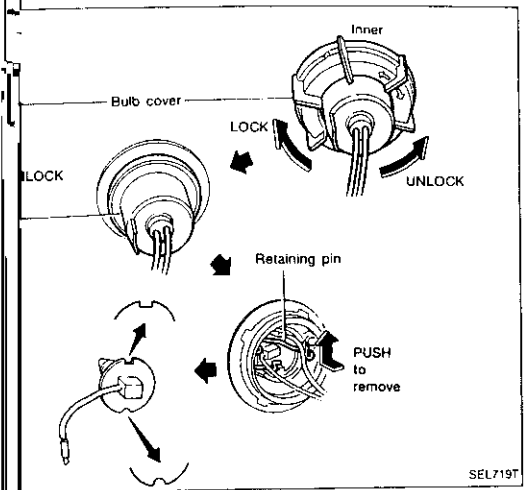

The headlamp is a semi-sealed beam type which uses a replaceable halogen bulb. The bulb can be replaced from the compartment side without removing the headlamp.

Replace only the plastic base when handling the bulb. Never touch the glass envelope.

1. Disconnect the battery cable.

2. Disconnect harness connector from rear end of bulb (outer).

3. Turn bulb cover counterclockwise, then remove it.

4. Remove rubber cap.

5. Turn and turn retaining pin to loosen it.

6. Remove headlamp bulb. Do not shake or rotate bulb when moving it.

7. Reconnect harness connector (Inner).

8. Install in the reverse order of removal.

JN:

Do not leave headlamp reflector without bulb for a long period of time. Dust, moisture, smoke, etc. entering headlamp body may affect the performance of the headlamp.

Remove headlamp bulb from the headlamp reflector just before a replacement bulb is installed.

### Specifications

Item	Wattage (W)
High/Low (H4 type)	60/55
Low (H3 type)	55



System Description

The headlamps are controlled by the lighting switch which is built into the combination switch.

MODELS FOR EUROPE

Power is supplied at all times

- to lighting switch terminal ⑤
- through 20A fuse (No. 37), located in the fusible link and fuse box), and
- to lighting switch terminal ⑧
- through 20A fuse (No. 38), located in the fusible link and fuse box).

Low beam operation

When the lighting switch is turned to the 2ND position and placed in LOW ("B") position, power is supplied

- from lighting switch terminal ⑩
- to terminal ③ of the LH headlamp, and
- from lighting switch terminal ⑦
- to terminal ③ of the RH headlamp.

Terminal ② of each headlamp supplies ground through body ground (E43) or (E57).  
With power and ground supplied, the low beam headlamps will illuminate.

High beam operation/flash-to-pass operation

When the lighting switch is turned to the 2ND position and placed in HIGH ("A") position or PASS ("C") position, power is supplied

- from lighting switch terminal ⑥
- to terminals ① (Outer) and ④ (Inner) of RH headlamp, and
- from lighting switch terminal ⑨
- to terminals ① (Outer) and ④ (Inner) of LH headlamp, and
- to combination meter terminal ⑦ for the high beam indicator.

Ground is supplied to terminal ③⑥ of the combination meter through body ground (M1).

Terminals ② (Outer) and ⑤ (Inner) of headlamp supply ground through body ground (E43) or (E57).  
With power and ground supplied, the high beams and the high beam indicator will illuminate.

MODELS EXCEPT FOR EUROPE

Power is supplied at all times

- to lighting switch terminal ⑤
- through 20A fuse (No. 38), located in the fusible link and fuse box), and
- to lighting switch terminal ⑧
- through 20A fuse (No. 37), located in the fusible link and fuse box).

Low beam operation

When the lighting switch is turned to the 2ND position and placed in LOW ("B") position, power is supplied

- from lighting switch terminal ⑦
- to terminal ③ of the LH headlamp, and
- from lighting switch terminal ⑩
- to terminal ③ of the RH headlamp.

Terminal ② of each headlamp supplies ground through body ground (E43) or (E57).  
With power and ground supplied, the low beam headlamps will illuminate.

High beam operation/flash-to-pass operation

When the lighting switch is turned to the 2ND position and placed in HIGH ("A") position or PASS ("C") position, power is supplied

- from lighting switch terminal ⑨
- to terminals ① (Outer) and ④ (Inner) of each RH headlamp, and
- from lighting switch terminal ⑥
- to terminals ① (Outer) and ④ (Inner) of each LH headlamp, and
- to combination meter terminal ⑦ for the high beam indicator.

Ground is supplied to terminal ③⑥ of the combination meter through body ground (M1).

Terminals ② (Outer) and ⑤ (Inner) of each headlamp supply ground through body ground (E43) or (E57).  
With power and ground supplied, the high beams and the high beam indicator will illuminate.

Schematic

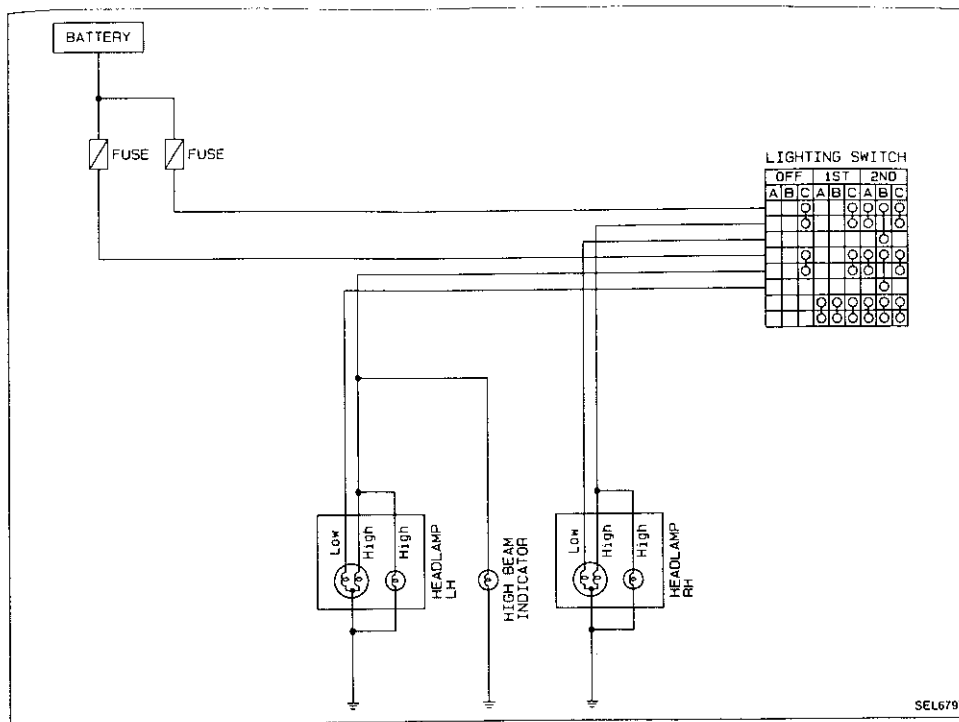

SEL679T

HEADLAMP — Without Daytime Light System —

Wiring Diagram — H/LAMP —

EL-H/LAMP-01

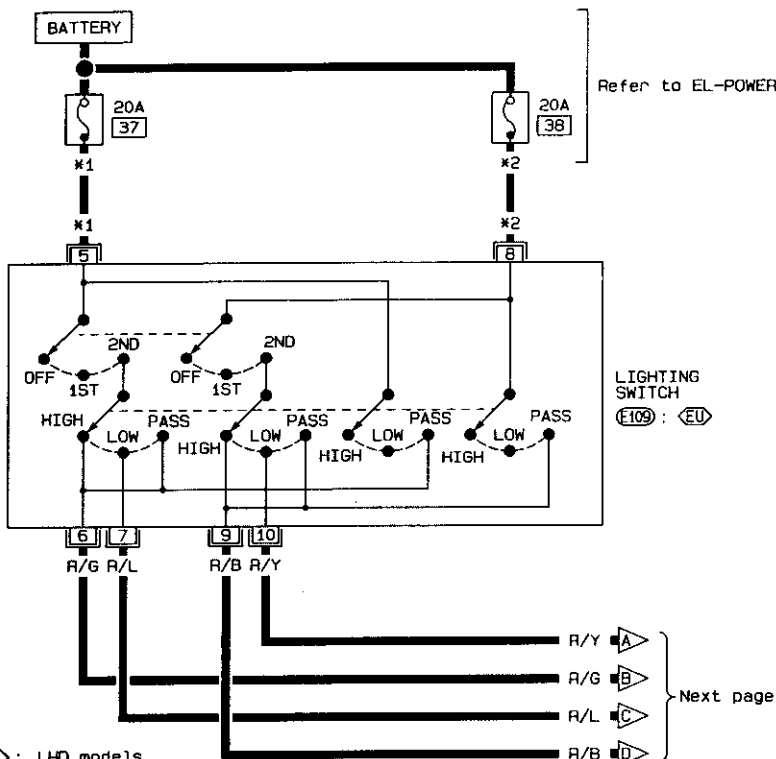

- <L> : LHD models
- <R> : RHD models
- <EU> : For Europe
- \*1... <L> R, <R> R/W
- \*2... <L> R/W, <R> R

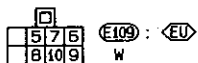

HEADLAMP — Without Daytime Light System —  
Wiring Diagram — H/LAMP — (Cont'd)

EL-H/LAMP-02

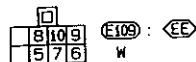
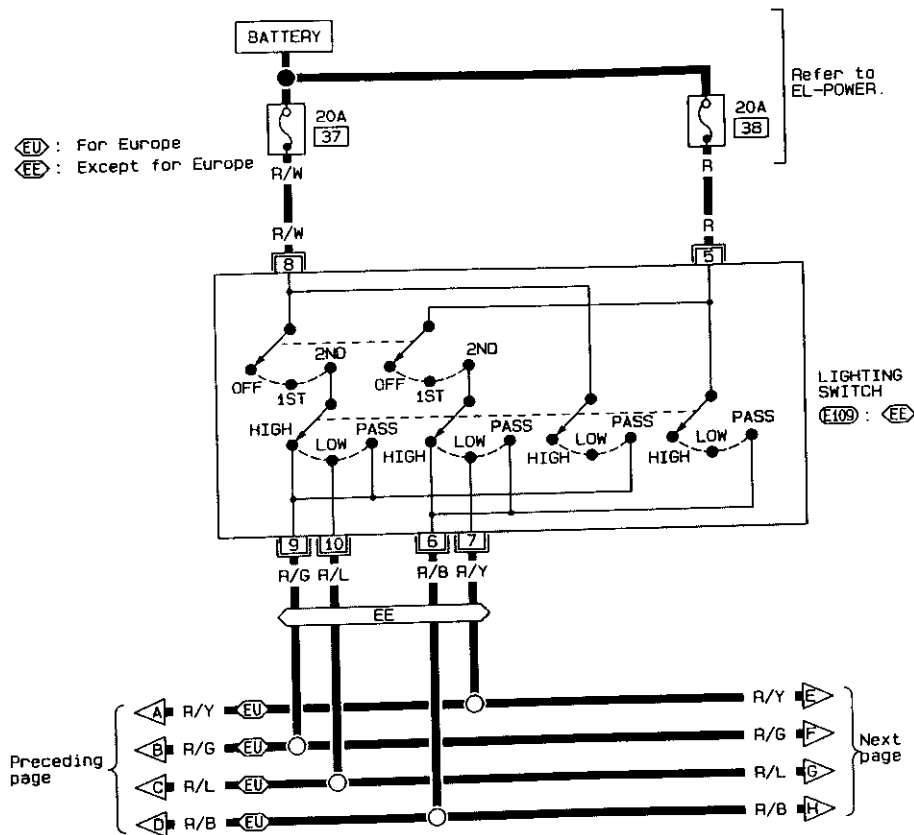

W  
V  
F  
L  
E  
P  
C  
R  
E  
C  
L  
W  
A  
T  
P  
F  
A  
R  
A  
B  
S  
T  
R  
A  
S  
B  
T  
H  
A  
E  
L  
C  
M

HEADLAMP — Without Daytime Light System —  
Wiring Diagram — H/LAMP — (Cont'd)

EL-H/LAMP-03

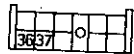
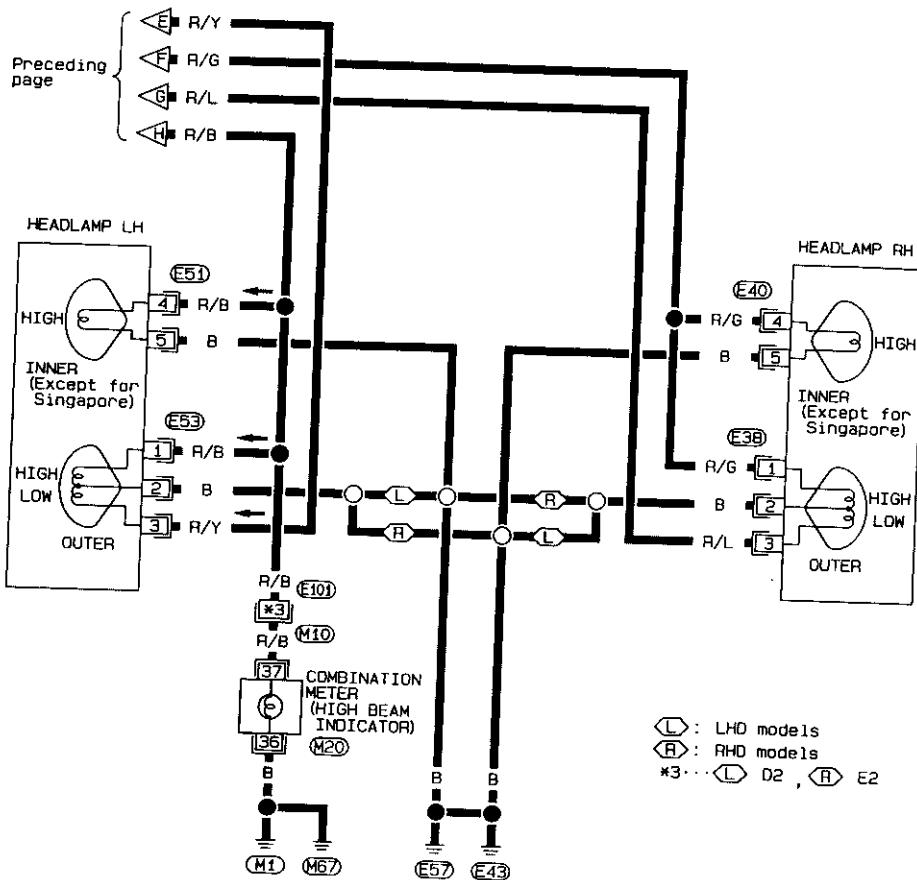

M20



E38

E53

B

E40

E51

GY

GY

Refer to last page (Foldout page).

(M10), (E10)

HEADLAMP — Without Daytime Light System —

Trouble Diagnoses

Symptom	Possible cause	Repair order
LH headlamps do not operate.	<ol style="list-style-type: none"> <li>1. Bulb</li> <li>2. Ground (E43) or (E57)</li> <li>3. 20A fuse</li> </ol>	<ol style="list-style-type: none"> <li>1. Check bulb.</li> <li>2. Check ground (E43) or (E57).</li> <li>3. Check 20A fuse (No. 38) . located in fusible link and fuse box). Verify battery positive voltage is present at terminal *1 of lighting switch.</li> <li>4. Check lighting switch.</li> </ol>
RH headlamps do not operate.	<ol style="list-style-type: none"> <li>1. Bulb</li> <li>2. Ground (E43) or (E57)</li> <li>3. 20A fuse</li> </ol>	<ol style="list-style-type: none"> <li>1. Check bulb.</li> <li>2. Check ground (E43) or (E57).</li> <li>3. Check 20A fuse (No. 37) . located in fusible link and fuse box). Verify battery positive voltage is present at terminal *2 of lighting switch.</li> <li>4. Check lighting switch.</li> </ol>
LH high beams do not operate, but LH low beam operates.	<ol style="list-style-type: none"> <li>1. Bulbs</li> <li>2. Open in LH high beams circuit</li> <li>3. Lighting switch</li> </ol>	<ol style="list-style-type: none"> <li>1. Check bulbs.</li> <li>2. Check R/B wire between lighting switch and LH headlamps for an open circuit.</li> <li>3. Check lighting switch.</li> </ol>
LH low beam does not operate, but LH high beam operates.	<ol style="list-style-type: none"> <li>1. Bulb</li> <li>2. Open in LH low beam circuit</li> <li>3. Lighting switch</li> </ol>	<ol style="list-style-type: none"> <li>1. Check bulb.</li> <li>2. Check R/Y wire between lighting switch and LH headlamp for an open circuit.</li> <li>3. Check lighting switch.</li> </ol>
RH high beams do not operate, but RH low beam operates.	<ol style="list-style-type: none"> <li>1. Bulbs</li> <li>2. Open in RH high beams circuit</li> <li>3. Lighting switch.</li> </ol>	<ol style="list-style-type: none"> <li>1. Check bulbs.</li> <li>2. Check R/G wire between lighting switch and RH headlamps for an open circuit.</li> <li>3. Check lighting switch.</li> </ol>
RH low beam does not operate, but RH high beam operates.	<ol style="list-style-type: none"> <li>1. Bulb</li> <li>2. Open in RH low beam circuit</li> <li>3. Lighting switch</li> </ol>	<ol style="list-style-type: none"> <li>1. Check bulb.</li> <li>2. Check R/L wire between lighting switch and RH headlamp for an open circuit.</li> <li>3. Check lighting switch.</li> </ol>
High beam indicator does not work.	<ol style="list-style-type: none"> <li>1. Bulb</li> <li>2. Ground (M1)</li> <li>3. Open in high beam circuit</li> </ol>	<ol style="list-style-type: none"> <li>1. Check bulb in combination meter.</li> <li>2. Check ground (M1).</li> <li>3. Check R/B wire between lighting switch and combination meter for an open circuit.</li> </ol>

\*1: (8) ... Models for Europe  
(5) ... Models except for Europe

\*2: (5) ... Models for Europe  
(8) ... Models except for Europe

**Daytime Light System —**

**System Description (Cont'd)**

Switch in the OFF position, power is supplied

Headlamp through body ground (E45) or (E87).  
Daytime light unit through body ground (E43).

**Operation (Daytime light system)**

The headlamps' low beam and clearance, license, tail and illumination lamps automatically turn on after starting the engine with lighting switch in "OFF" position. Lighting switch operations other than the above are the same as conventional light systems.

With engine stopped						With engine running								
1ST			2ND			OFF			1ST			2ND		
A	B	C	A	B	C	A	B	C	A	B	C	A	B	C
X	X	O	O	X	O	X	X	O	X	X	O	O	X	O
X	X	X	X	O	X	O	O	O	X	X	X	X	O	X
O	O	O	O	O	O	O	O	O	O	O	O	O	O	O
O	O	O	O	O	O	O	O	O	O	O	O	O	O	O

# HEADLAMP — Daytime Light System —

Schematic

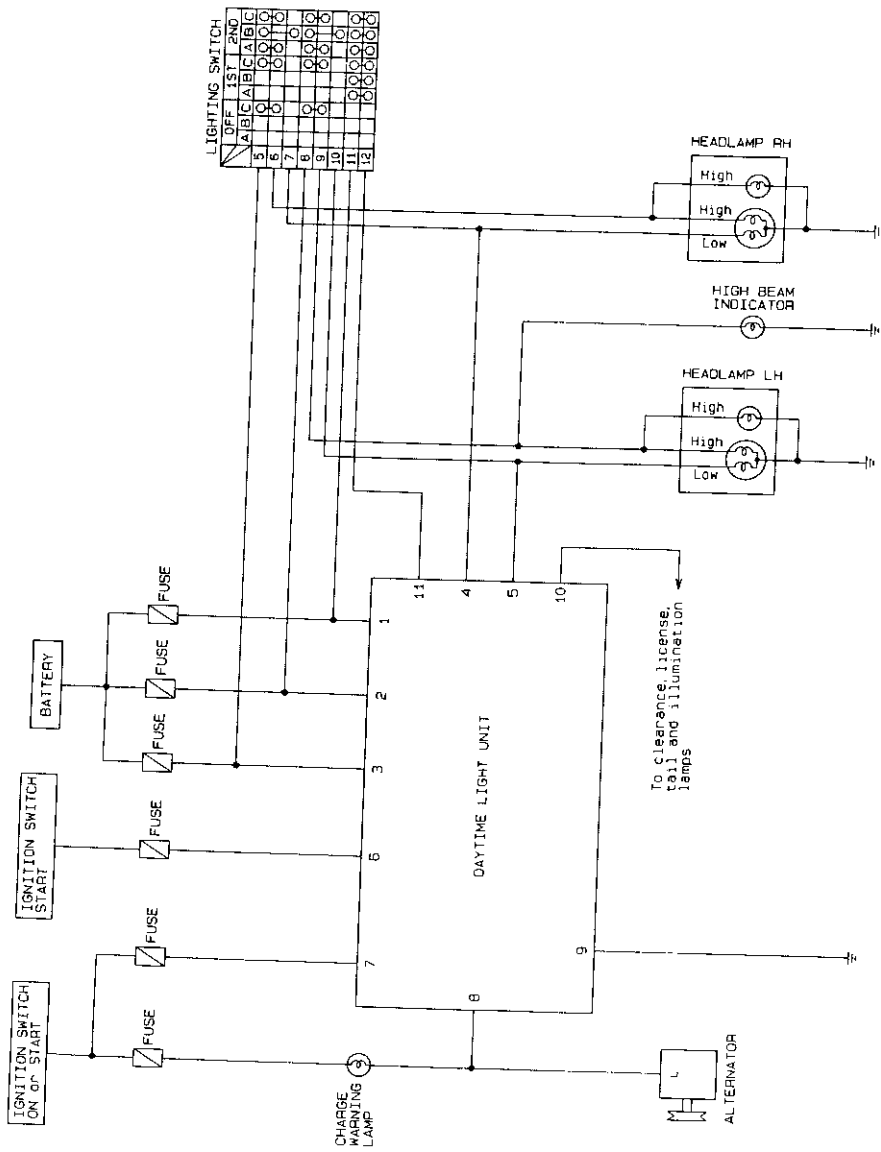

EL-58

SFI 683T

# HEADLAMP — Daytime Light System —

Wiring Diagram — DTRL —

EL-DTRL-01

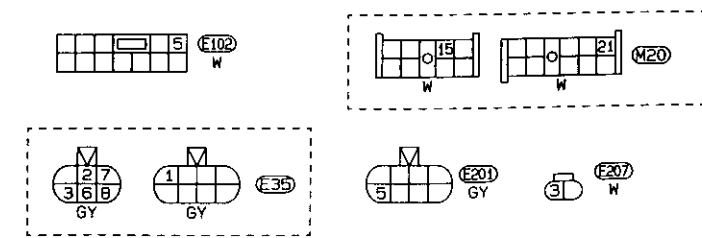
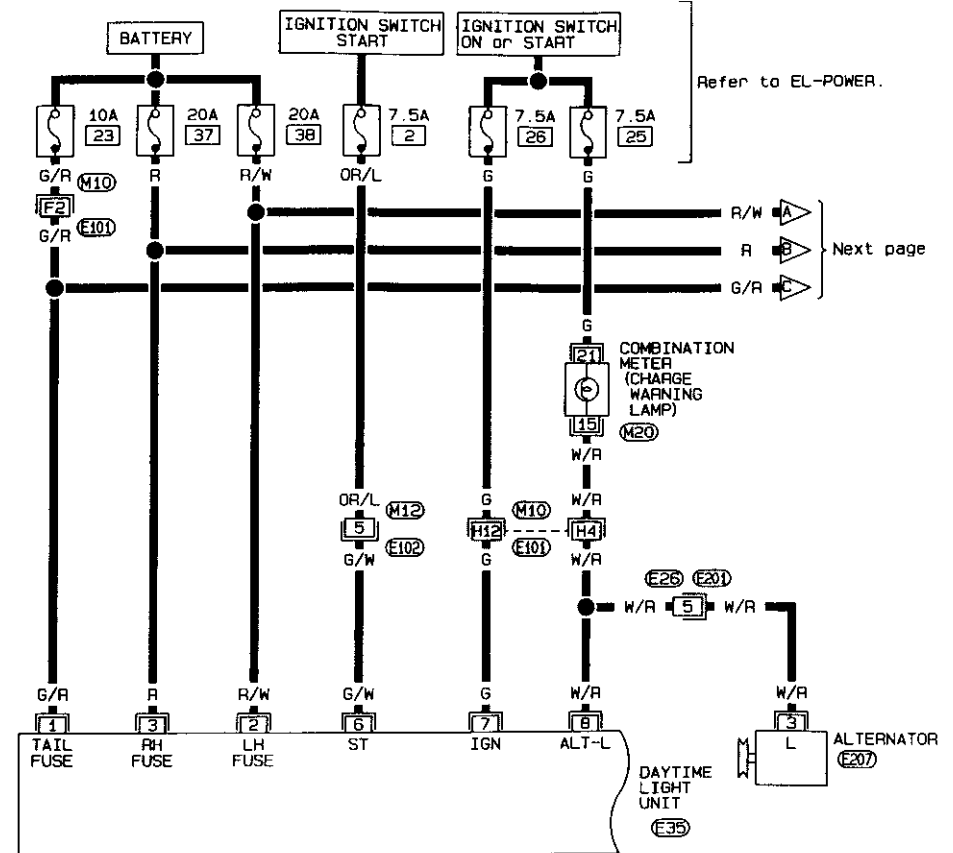

Refer to last page (Foldout page).

M10, E101

EL-59

SFI 684T

EL

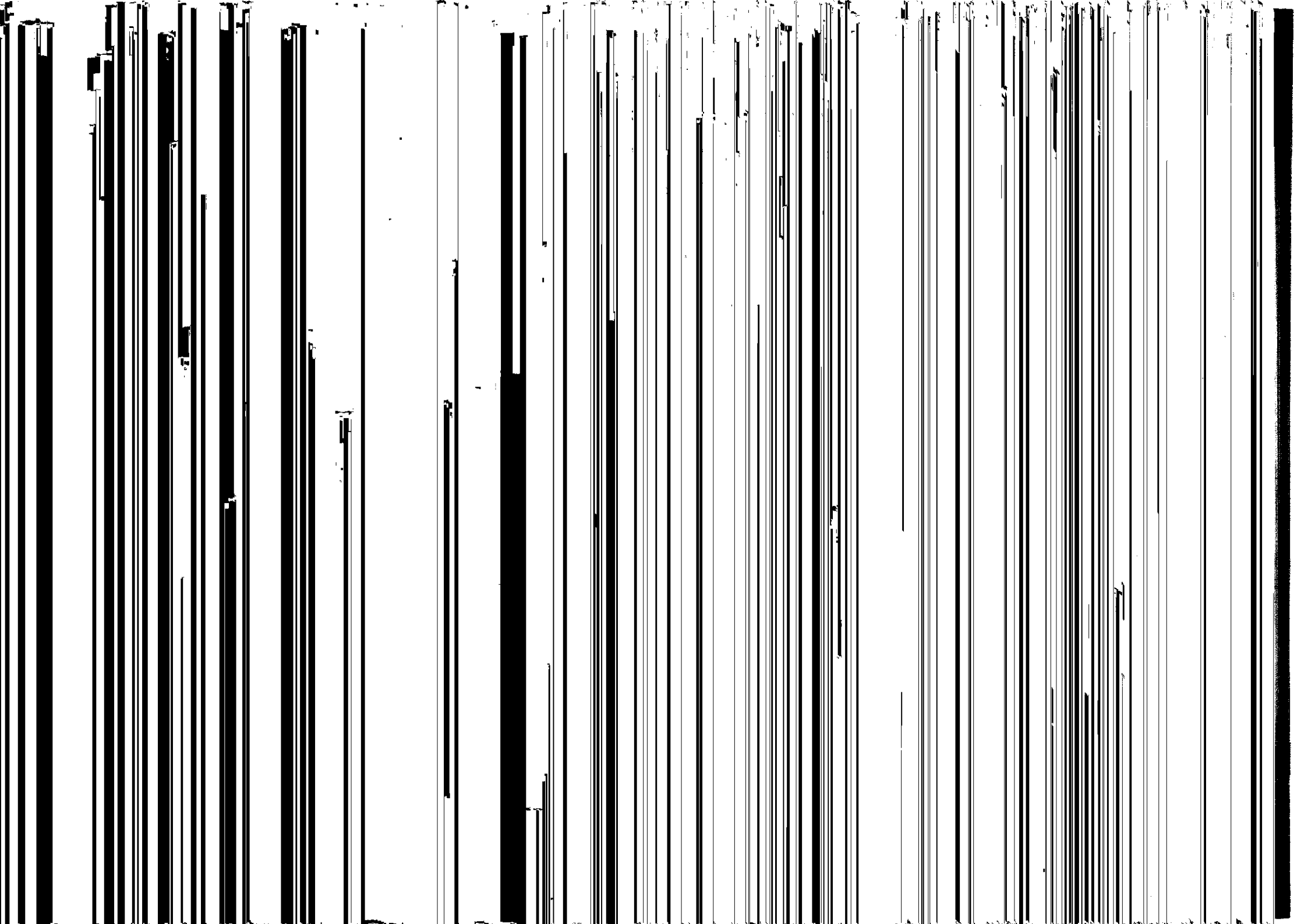

















HEADLAMP — Daytime Light System —

Trouble Diagnoses

DAYTIME LIGHT UNIT INSPECTION TABLE

(Data are reference values.)

Terminal No.	Item	Condition	Judgement standard
1	Power source (BAT)	 When turning ignition switch to "ON"	Battery positive voltage
		 When turning ignition switch to "OFF"	Battery positive voltage
2	Power source (BAT)	 When turning ignition switch to "ON"	Battery positive voltage
		 When turning ignition switch to "OFF"	Battery positive voltage
3	Power source (BAT)	 When turning ignition switch to "ON"	Battery positive voltage
		 When turning ignition switch to "OFF"	Battery positive voltage
4	RH to beam (Lighting switch)	When turning lighting switch to "HEAD" and 2ND positions	Battery positive voltage
		 When turning lighting switch to "OFF" with engine running (daytime light operation)	Battery positive voltage
5	LH to beam (Lighting switch)	When turning lighting switch to "HEAD" and 2ND positions	Battery positive voltage
		 When turning lighting switch to "OFF" with engine running (daytime light operation)	Battery positive voltage
6	Start signal	 When turning ignition switch to "ST"	Battery positive voltage
		 When turning ignition switch to "ON" from "ST"	1V or less
		 When turning ignition switch to "OFF"	1V or less
7	Power source (IGN)	 When turning ignition switch to "ON"	Battery positive voltage
		 When turning ignition switch to "ST"	Battery positive voltage
		 When turning ignition switch to "OFF"	1V or less
8	Alternator	 When turning ignition switch to "ON"	More than 5V
		 When engine is running	Battery positive voltage
		 When turning ignition switch to "OFF"	1V or less

HEADLAMP — Daytime Light System —

Trouble Diagnoses (Cont'd)

Terminal No.	Item	Condition	Judgement standard
9	Ground	—	—
10	Small lamps	When turning lighting switch to 1ST or 2ND position	Battery positive voltage
		 When turning lighting switch to "OFF" with engine running (daytime light operation)	Battery positive voltage
11	Lighting switch	When turning lighting switch to 1ST or 2ND position	Battery positive voltage
		When turning lighting switch to "OFF"	1V or less

GI  
MA  
EM  
LC  
EC  
BE  
CL  
MT  
AT  
FO  
EA  
BA  
RN  
ST  
ES  
RT  
HA  
EL  
HX

## Headlamp Aiming Control

### Description

Beam can be adjusted from inside the vehicle. This prevents forward due to changes in number of occupants and vehicle

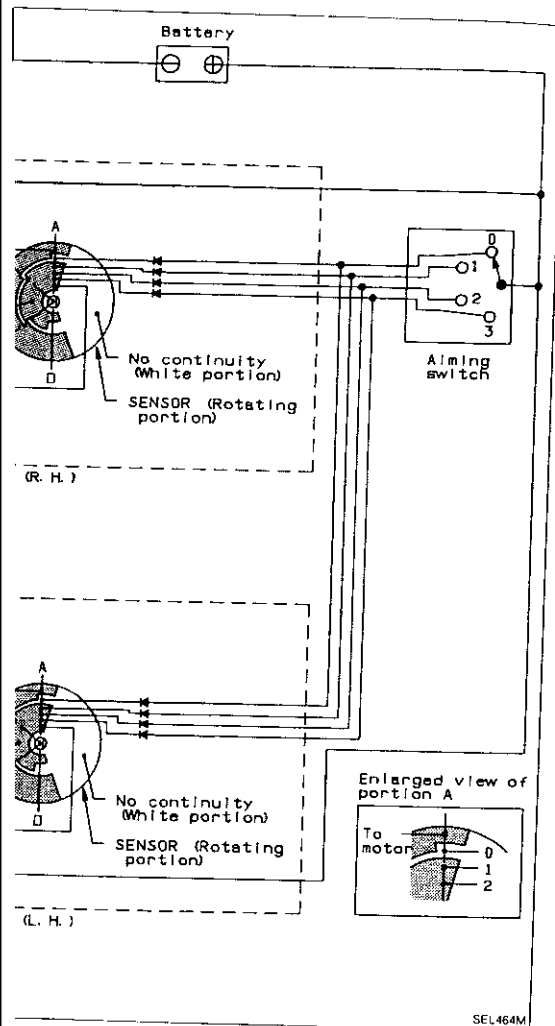

## HEADLAMP — Headlamp Aiming Control — Description (Cont'd)

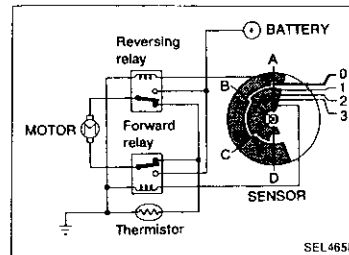
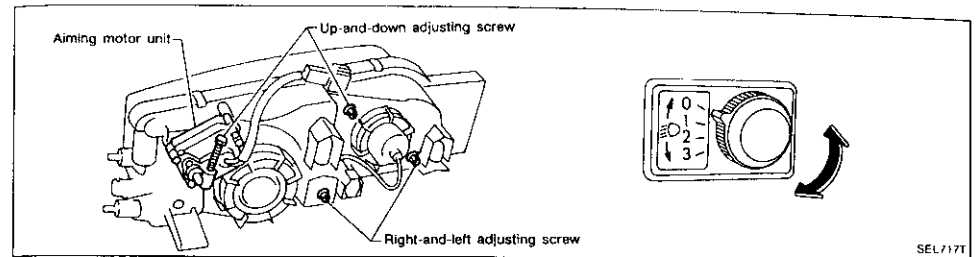

### CIRCUIT OPERATION

#### [Example]

#### Aiming switch "0"

- When the aiming switch is set to "0", the motor will not start. This is because the power terminals are positioned at the nonconductive section of the sensor's rotary unit.

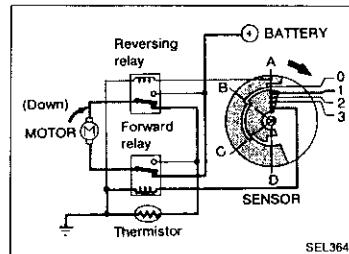

#### Aiming switch "0" → "1"

- When the aiming switch is moved from "0" to "1", the sensor's conductive section activates the relay. Power is supplied through the relay to the motor. The headlamps will then move in the "DOWN" direction.
- The motor continues to rotate while the rotary unit of the sensor moves from point A to point B.
- The power terminals will then be positioned at the nonconductive section, disconnecting the power to the motor. The motor will then stop.

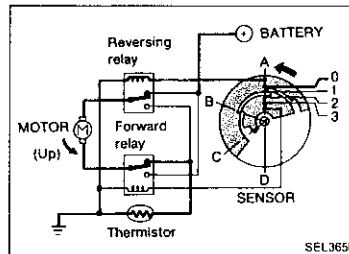

#### Aiming switch "1" → "0"

- When the aiming switch is moved from "1" to "0", the sensor's conductive section activates the relay. Power is supplied through the relay to the motor. The motor will rotate to move the headlamps in the "UP" direction.
- When the rotary unit of the sensor moves from point B to point A, the motor will stop.



# HEADLAMP — Headlamp Aiming Control —

## Wiring Diagram — AIM —

LHD MODELS

EL-AIM-01

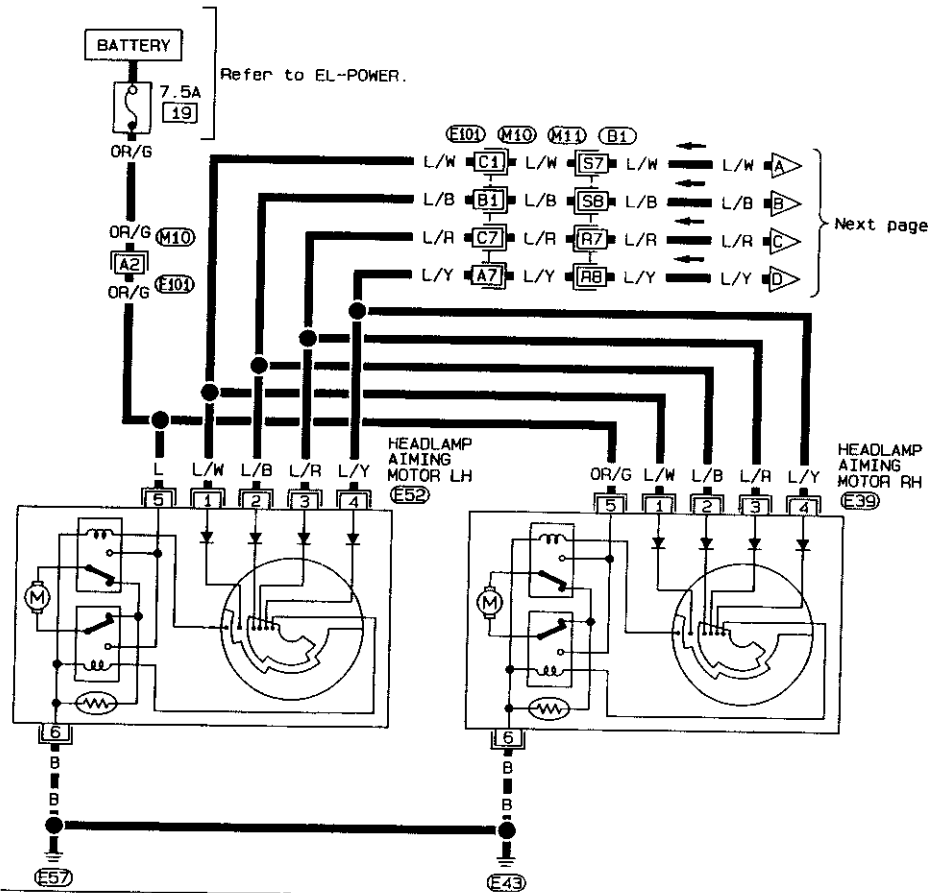

Refer to last page (Foldout page).

M10, E101  
M11, B1

EL-66

SEL687T

# HEADLAMP — Headlamp Aiming Control —

## Wiring Diagram — AIM — (Cont'd)

EL-AIM-02

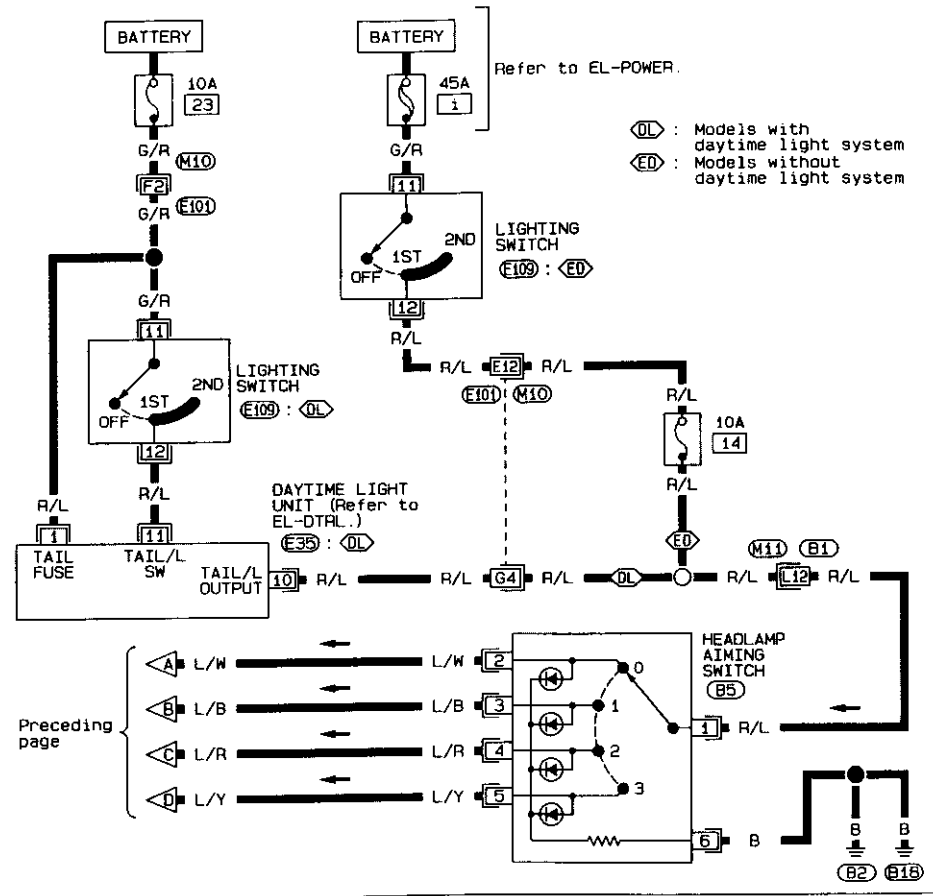

Refer to last page (Foldout page).

M10, E101  
M11, B1

EL-67

SEL688T

EL

MAX

HEADLAMP — Headlamp Aiming Control —  
Wiring Diagram — AIM — (Cont'd)

RHD MODELS

EL-AIM-03

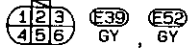
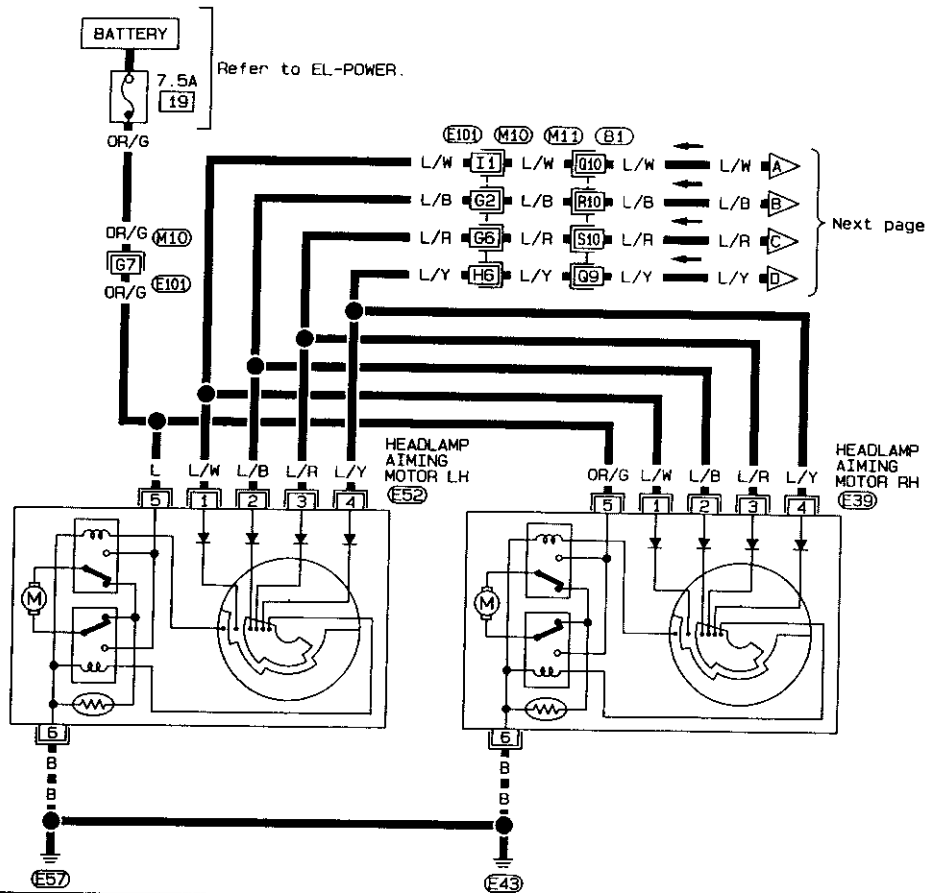

Refer to last page (Foldout page).

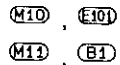

EL-68

SEL689T

HEADLAMP — Headlamp Aiming Control —  
Wiring Diagram — AIM — (Cont'd)

EL-AIM-04

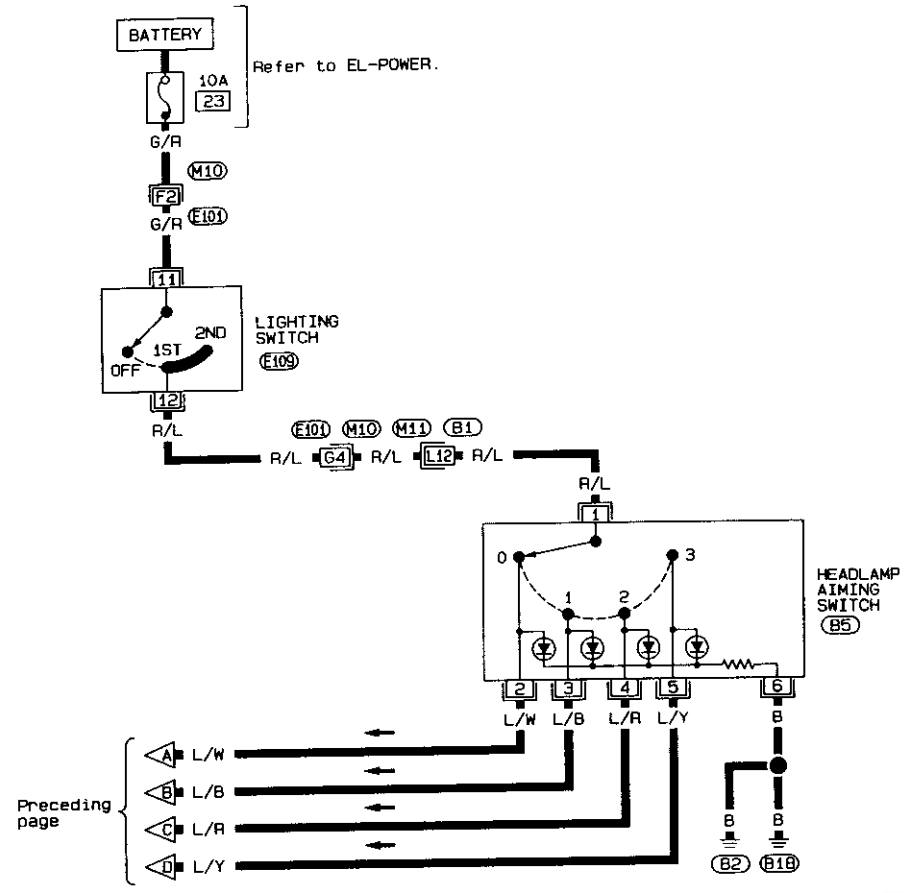

Preceding page

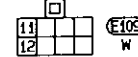
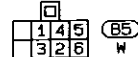

Refer to last page (Foldout page).

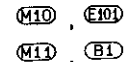

EL-69

SEL690T

GE  
MA  
EM  
IC  
PC  
FE  
GL  
MT  
AT  
PO  
EJ  
SE  
PE  
44  
42  
41  
40  
39  
38  
37  
36  
35  
34  
33  
32  
31  
30  
29  
28  
27  
26  
25  
24  
23  
22  
21  
20  
19  
18  
17  
16  
15  
14  
13  
12  
11  
10  
9  
8  
7  
6  
5  
4  
3  
2  
1

EL

10X

### Aiming Adjustment

When performing headlamp aiming adjustment, use an aiming machine, aiming wall screen or headlamp tester. Aimers should be in good repair, calibrated and operated according to their operation manuals.

If any aimer is not available, aiming adjustment can be done as follows:

For details, refer to the regulations in your own country.

#### CAUTION:

- Keep all tires inflated to correct pressures.
- Place vehicle and tester on one and same flat surface.
- See that there is no-load in vehicle (coolant, engine oil filled up to correct level and full fuel tank) other than the driver (or equivalent weight placed in driver's position).

#### CAUTION:

Be sure aiming switch is set to "0" when performing aiming adjustment on vehicles equipped with headlamp aiming control.

#### LOW BEAM

1. Turn headlamp low beam on.
  2. Use adjusting screws to perform aiming adjustment.
- First tighten the adjusting screw all the way and then make adjustment by loosening the screw.

- Adjust headlamps so that main axis of light is parallel to center line of body and is aligned with point P shown in illustration.

- Figure to the left shows headlamp aiming pattern for driving on right side of road; for driving on left side of road, aiming pattern is reversed.

- Dotted lines in illustration show center of headlamp.

- "H": Horizontal center line of headlamps
- "W<sub>L</sub>": Distance between each headlamp center
- "L": 5,000 mm (196.85 in)
- "C": 65 mm (2.56 in)

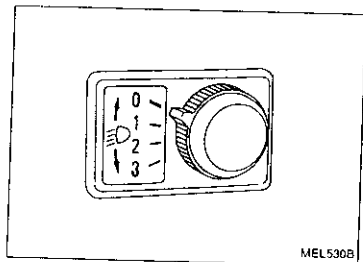

MEL530B

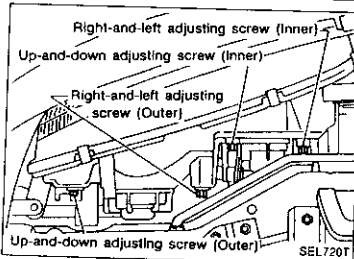

SEL720T

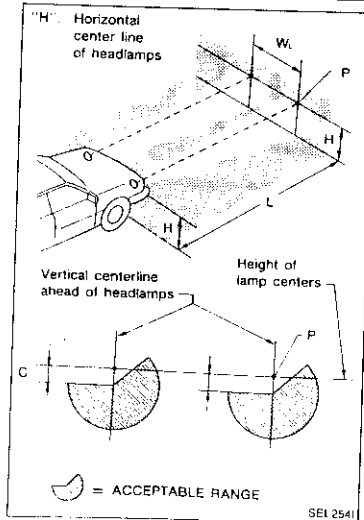

SEL1254I

### Trouble Diagnoses

SYMPTOM: Headlamp aiming does not operate.

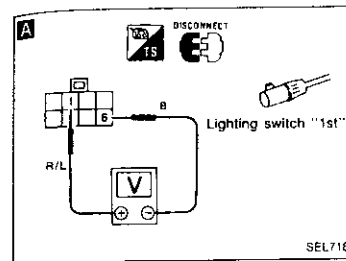

SEL718T

**A** POWER SUPPLY CIRCUIT CHECK (For aiming switch)  
Check if 12 volts exist between terminals ① and ⑥

Voltmeter terminals		Voltage [V]
(+)	(-)	
①	⑥	Approx. 12

NG → Check 10A fuse at fuse block. (Refer to "POWER SUPPLY ROUTING".)

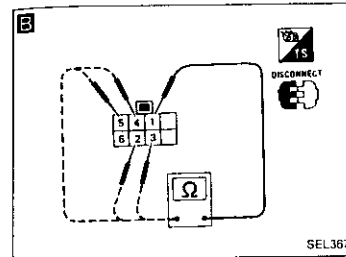

SEL387P

**B** AIMING SWITCH CHECK  
Check continuity between terminals at each switch position

Terminal	①	②	③	④	⑤
Switch position 0	○	○			
1	○	○	○		
2	○		○	○	
3	○			○	○

NG → Replace aiming switch.

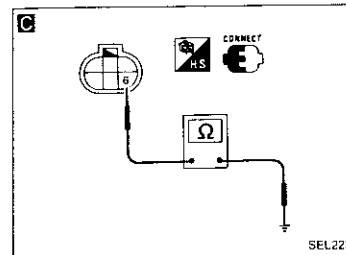

SEL223P

**C** GROUND CIRCUIT CHECK FOR AIMING MOTOR  
Check continuity between terminals ⑥ and body ground.  
Continuity exists ... OK

NG → Repair harness between aiming motor and body ground.

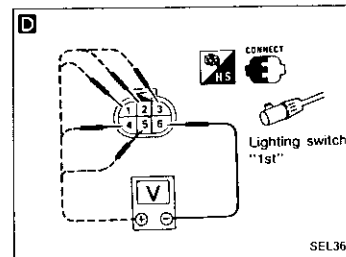

SEL368P

**D** POWER SUPPLY CIRCUIT CHECK (For aiming motor unit)  
Check if 12 volts exist between terminals ①, ②, ③, ④, ⑤ and ⑥.

Voltmeter terminals		Voltage [V]	Aiming switch position
(+)	(-)		
①	⑥	Approx. 12	"0"
		0	Except "0"
②	⑥	Approx. 12	"1"
		0	Except "1"
③	⑥	Approx. 12	"2"
		0	Except "2"
④	⑥	Approx. 12	"3"
		0	Except "3"
⑤	⑥	Approx. 12	---

NG → Check harness between aiming switch and aiming motor unit

OK → Replace aiming motor unit.

## EXTERIOR LAMP

### Clearance, License and Tail Lamps/System Description

#### LHD MODELS WITH DAYTIME LIGHT SYSTEM

The clearance, license and tail lamps on vehicles for Norway and Sweden contain a daytime light unit. The unit activates the small lamps whenever the engine and lighting switch are under the following conditions.

- Engine running
- Lighting switch in the OFF position

(For daytime light system, refer to "HEADLAMP — Daytime Light System —".)

#### Operation (when daytime light system is triggered.)

Power is supplied at all times

- through 10A fuse (No. 23), located in the fuse block
- to daytime light unit terminal ①.

With the engine running and the lighting switch in the OFF position, power is supplied

- through daytime light unit terminal ⑩
- to terminal ① of each lamp.

Ground is supplied to terminal ② of clearance lamps through body ground (E43) or (E57).

Ground is also supplied to terminal ② of license lamp and to terminal ④ of tail lamps through body ground (T19).

With power and ground supplied, the clearance, license and tail lamps illuminate.

#### Operation (when daytime light system is not triggered.)

Power is supplied at all times

- through 10A fuse (No. 23), located in the fuse block
- to lighting switch terminal ⑪.

With the lighting switch in the 1ST or 2ND position, power is supplied

- through lighting switch terminal ⑫
- to daytime light unit terminal ①
- through daytime light unit terminal ⑩
- to terminal ① of each lamp.

Ground is supplied to terminal ② of clearance lamps through body ground (E43) or (E57).

Ground is also supplied to terminal ② of license lamp and to terminal ④ of tail lamps through body ground (T19).

With power and ground supplied, the clearance, license and tail lamps illuminate.

#### LHD MODELS WITHOUT DAYTIME LIGHT SYSTEM

Power is supplied at all times

- through 45A fusible link (letter ①), located in the fusible link and fuse box
- to lighting switch terminal ⑪.

#### Operation

With the lighting switch in the 1ST or 2ND position, power is supplied

- from lighting switch terminal ⑫
- through 10A fuse (No. 14), located in the fuse block
- to terminal ① of clearance, license and RH tail lamps.

With the lighting switch in the 1ST or 2ND position, power is also supplied

- from lighting switch terminal ⑫
- through 7.5A fuse (No. 15), located in the fuse block
- to LH tail lamp terminal ①.

Ground is supplied to terminal ② of clearance lamps through body ground (E43) or (E57).

Ground is also supplied to terminal ② of license lamp and to terminal ④ of tail lamps through body ground (T19).

With power and ground supplied, the clearance, license and tail lamps illuminate.

## EXTERIOR LAMP

### Clearance, License and Tail Lamps/System Description (Cont'd)

#### RHD MODELS FOR EUROPE

Power is supplied at all times

- through 10A fuse (No. 23), located in the fuse block
- to lighting switch terminal ⑪.

#### Operation

With the lighting switch in the 1ST or 2ND position, power is supplied

- through the lighting switch terminal ⑫
- to terminal ① of each lamp.

Ground is supplied to terminal ② of clearance lamps through body ground (E43) or (E57).

Ground is also supplied to terminal ② of license lamp and to terminal ④ of tail lamps through body ground (T19).

With power and ground supplied, the clearance, license and tail lamps illuminate.

#### RHD MODELS EXCEPT FOR EUROPE

Power is supplied at all times

- through 10A fuse (No. 23), located in the fuse block
- to lighting switch terminal ⑫, and
- to front fog lamp relay terminal ⑥.

#### Operation (when front fog lamp system is not triggered.)

With the lighting switch in the 1ST or 2ND position, power is supplied

- through lighting switch terminal ⑪
- to terminal ① of each lamp.

Ground is supplied to terminal ② of clearance lamps through body ground (E43) or (E57).

Ground is also supplied to terminal ② of license lamp and to terminal ④ of tail lamps through body ground (T19).

#### Operation (when front fog lamp system is triggered.)

With the front fog lamp switch in the ON position:

- ground is supplied to front fog lamp relay terminal ② through the front fog lamp switch and body ground (E43).

The front fog lamp relay is energized and power is supplied

- through front fog lamp relay terminal ⑦
- to terminal ① of each lamp.

Ground is supplied to terminal ② of clearance lamps through body ground (E43) or (E57).

Ground is also supplied to terminal ② of license lamp and to terminal ④ of tail lamps through body ground (T19).

With power and ground supplied, the clearance, license and tail lamps illuminate.

GI

MA

EM

LC

EC

FP

CL

MT

AT

PD

FA

MA

RS

ST

RS

BT

FA

EL

EX

# EXTERIOR LAMP

## Clearance, License and Tail Lamps/ Wiring Diagram — TAIL/L —

LHD MODELS WITH DAYTIME LIGHT SYSTEM

EL-TAIL/L-01

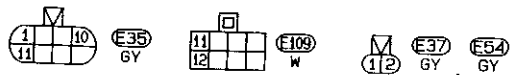
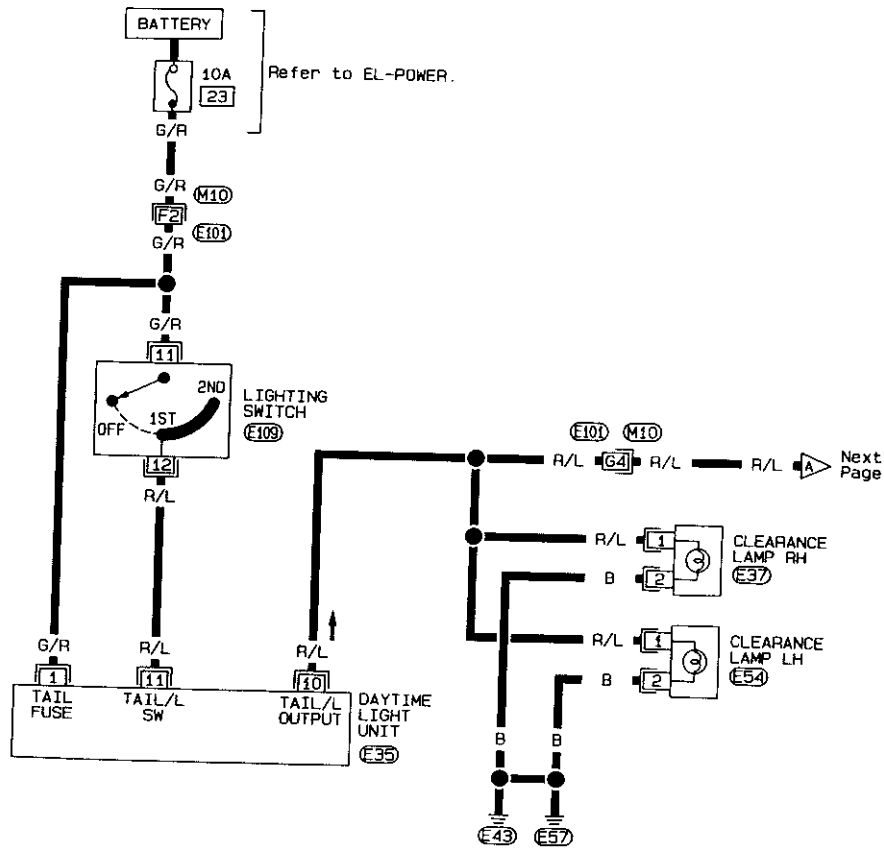

Refer to last page  
(Foldout page).

(M10), (E101)

# EXTERIOR LAMP

## Clearance, License and Tail Lamps/ Wiring Diagram — TAIL/L — (Cont'd)

EL-TAIL/L-02

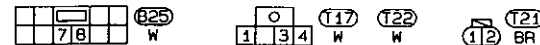
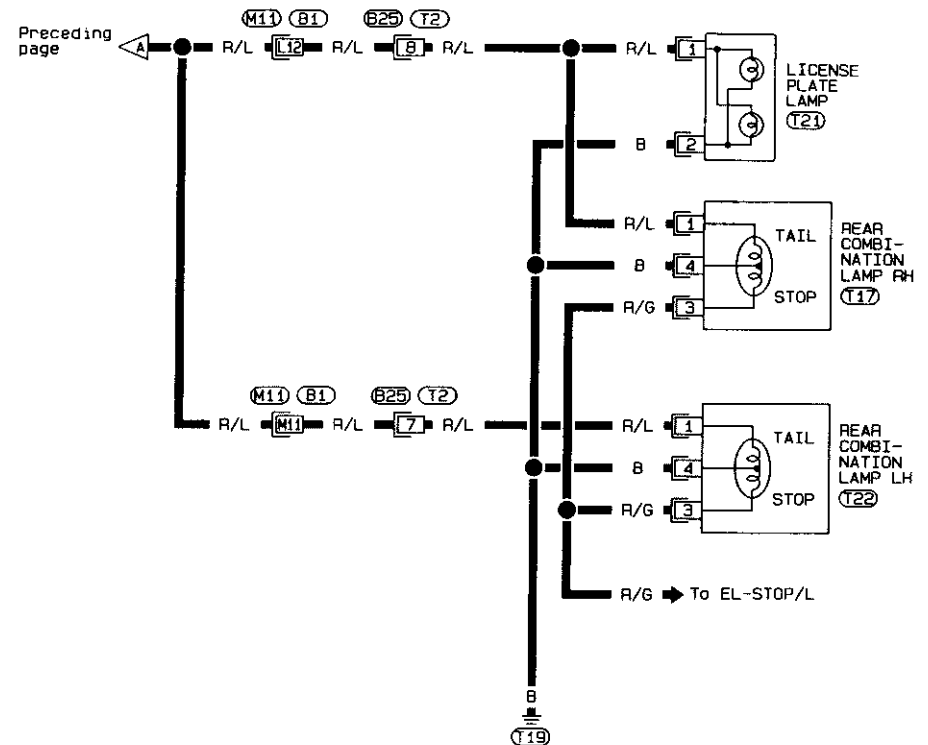

Refer to last page  
(Foldout page).

(M11), (B1)

se and Tail Lamps/  
TAIL/L — (Cont'd)

EL-TAIL/L-04

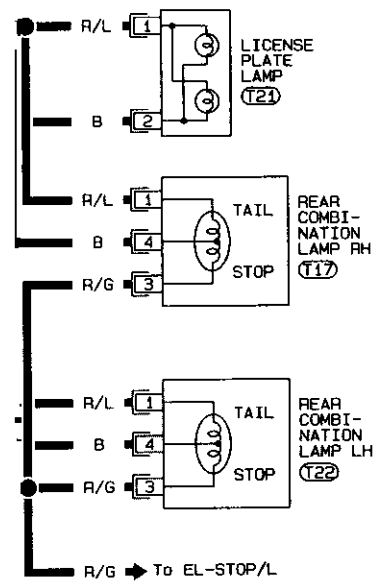

Refer to last page  
(Foldout page).

(M11), (B1)

- GI
- MA
- EM
- LC
- EC
- FE
- CL
- MT
- AT
- FD
- FA
- BA
- BR
- ST
- BS
- BT
- HA
- EL
- DA

### EXTERIOR LAMP

Clearance, License and Tail Lamps/  
Wiring Diagram — TAIL/L — (Cont'd)

RHD MODELS

EL-TAIL/L-05

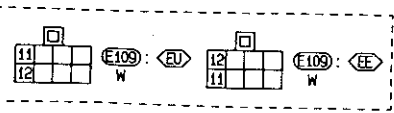
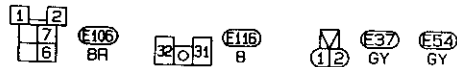
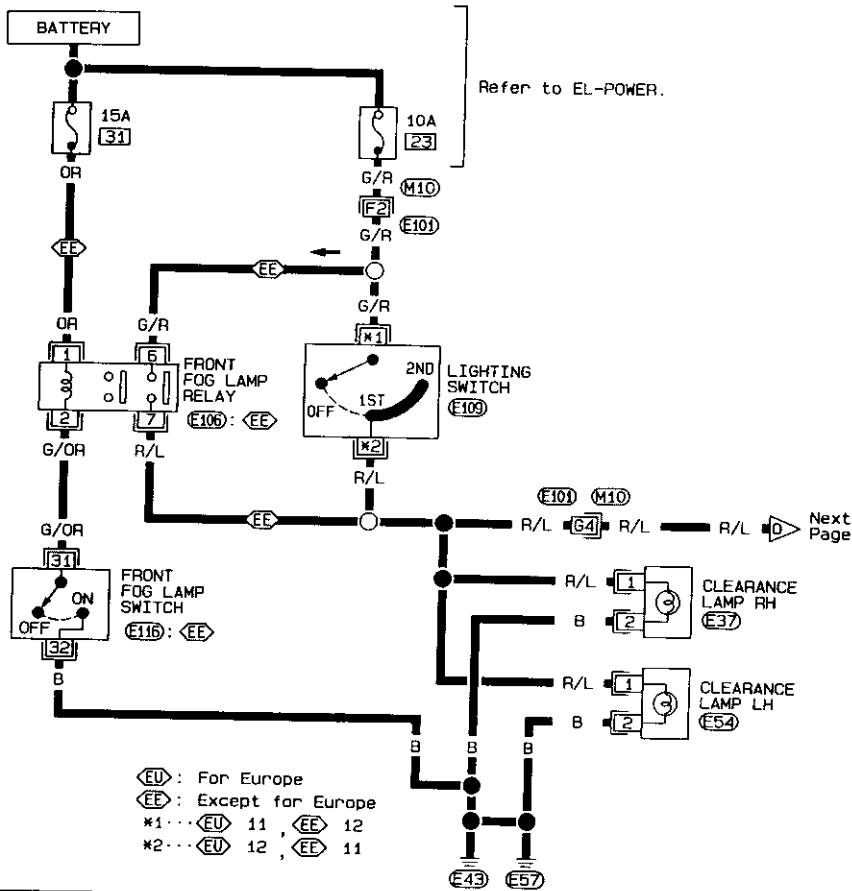

Refer to last page  
(Foldout page).  
M10, E101

EL-78

SEL 696T

### EXTERIOR LAMP

Clearance, License and Tail Lamps/  
Wiring Diagram — TAIL/L — (Cont'd)

EL-TAIL/L-06

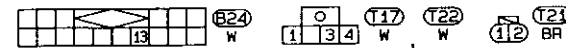
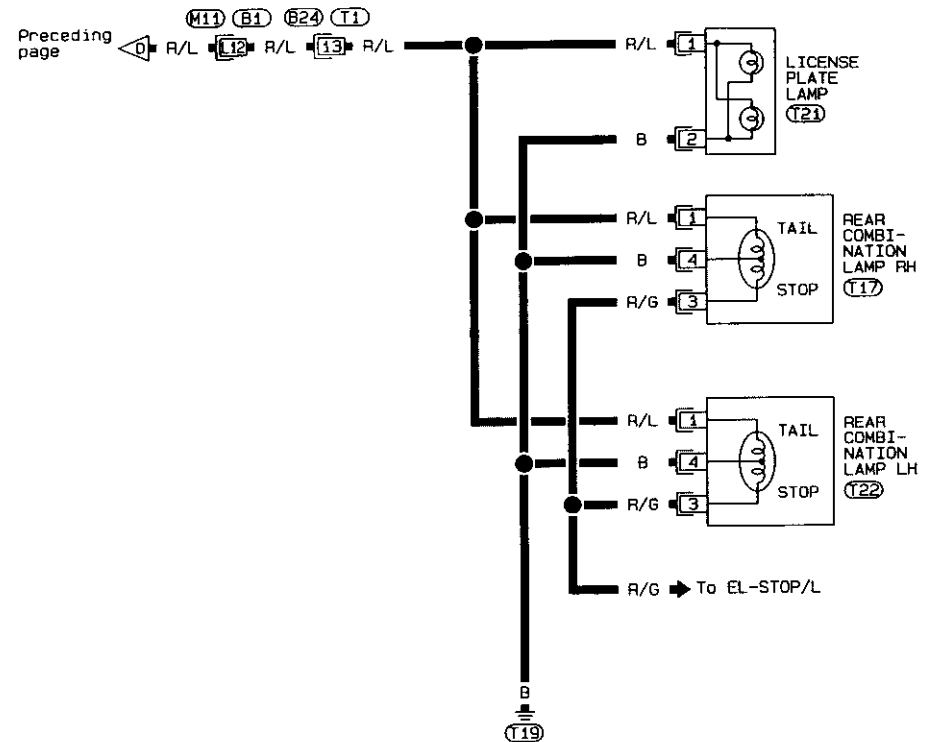

Refer to last page  
(Foldout page).  
M11, B1

EL-79

SEL 696T

GI  
MA  
EM  
LC  
EC  
FE  
CL  
MT  
AT  
PD  
FA  
RA  
BR  
ST  
RS  
BT  
MA  
EL  
OX

EXTERIOR LAMP

Stop Lamp/Wiring Diagram — STOP/L —

EL-STOP/L-01

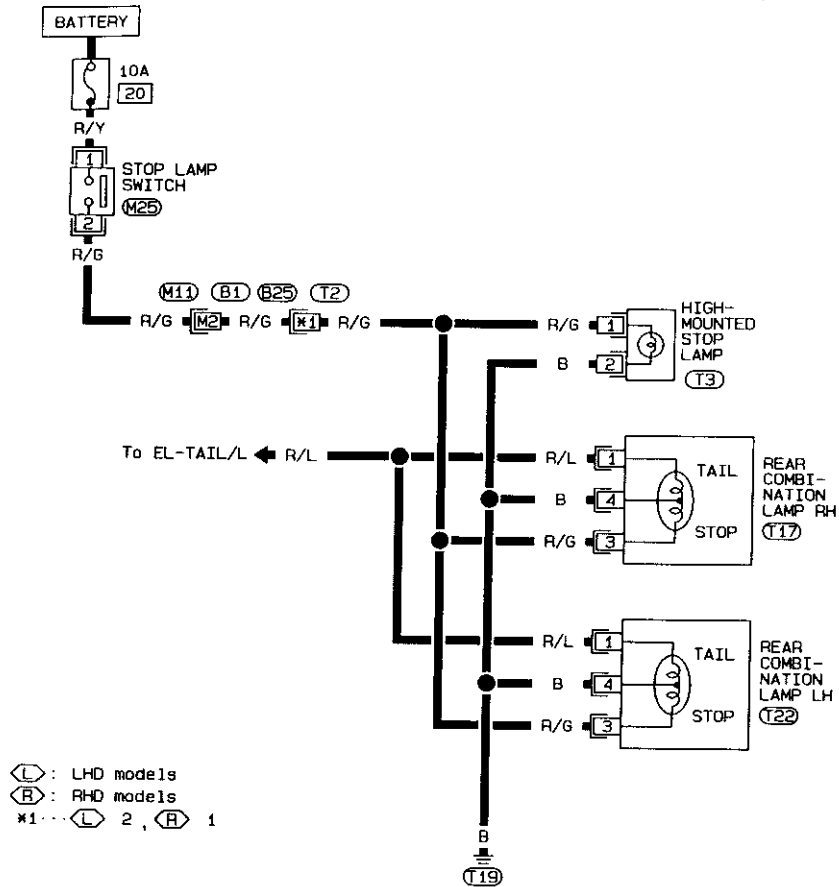

◁ L : LHD models  
 ▷ R : RHD models  
 \*1... ▷ 2, ▷ 1

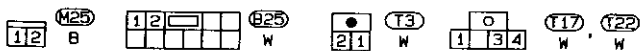

Refer to last page (Foldout page).

◁ M11, ▷ B1

EXTERIOR LAMP

Back-up Lamp/Wiring Diagram — BACK/L —

EL-BACK/L-01

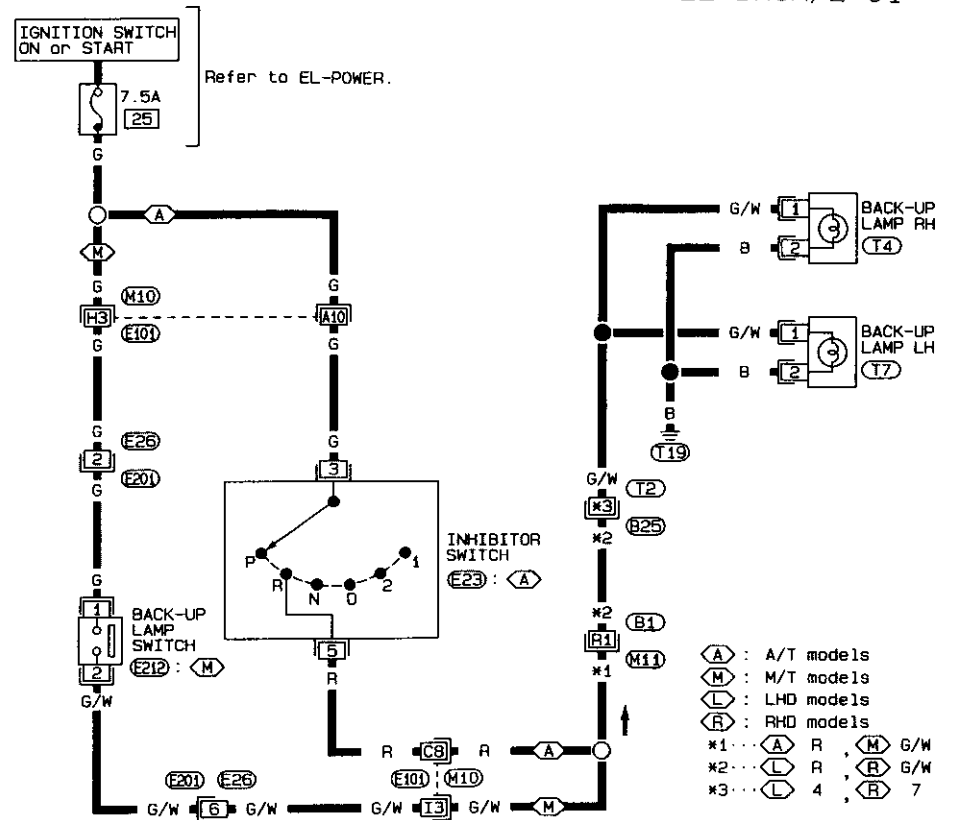

◁ A : A/T models  
 ▷ M : M/T models  
 ▷ L : LHD models  
 ▷ R : RHD models  
 \*1... ▷ A R, ▷ M G/W  
 \*2... ▷ L R, ▷ R G/W  
 \*3... ▷ L 4, ▷ R 7

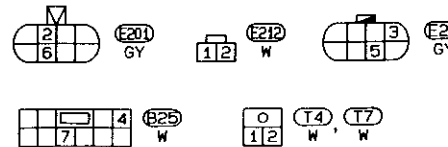

Refer to last page (Foldout page).

◁ M10, ▷ E101  
 ▷ M11, ▷ B1



GE  
WA  
EM  
LC  
ody  
EC  
FE  
CL  
WT  
AT  
und PD  
FA  
RA  
BR  
ST  
RS  
BT  
HA  
EL  
IDX

# EXTERIOR LAMP

## Front Fog Lamp/Wiring Diagram — F/FOG —

LHD MODELS WITH DAYTIME LIGHT SYSTEM

EL-F/FOG-01

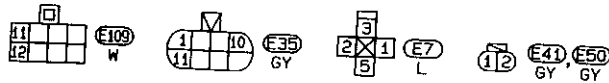
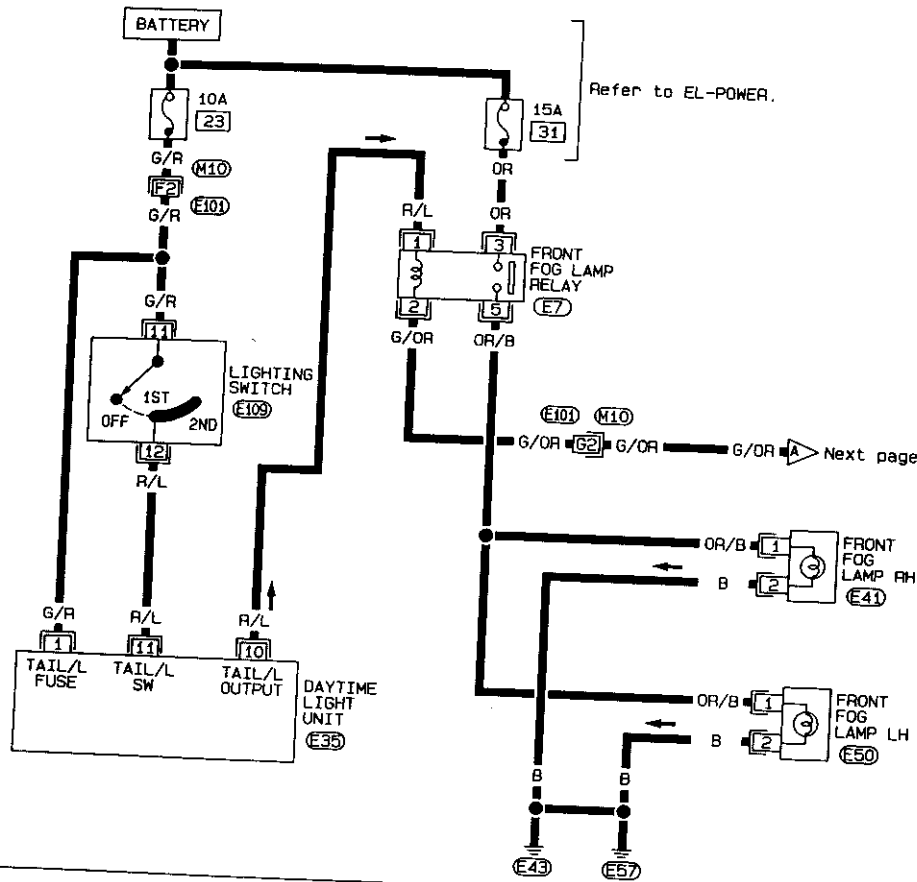

Refer to last page (Foldout page).

(M10, E10)

# EXTERIOR LAMP

## Front Fog Lamp/Wiring Diagram — F/FOG — (Cont'd)

EL-F/FOG-02

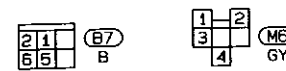
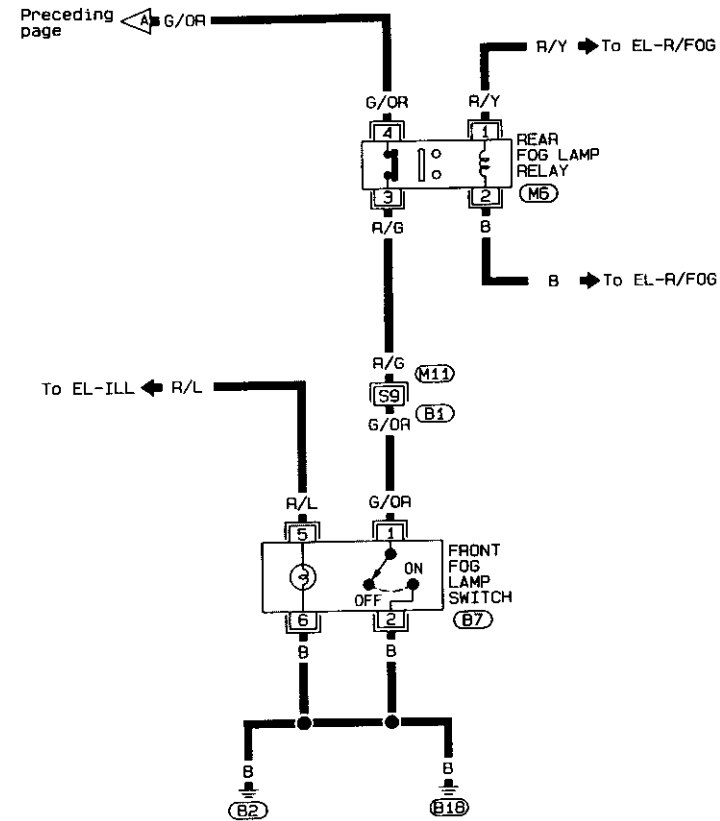

Refer to last page (Foldout page).

(M11, B1)

GI  
VA  
EW  
IC  
EC  
FE  
CL  
WT  
AT  
PD  
SA  
RA  
BH  
ST  
NS  
BT  
HA  
EL  
DX

EXTERIOR LAMP

Front Fog Lamp/Wiring Diagram — F/FOG —  
(Cont'd)

LHD MODELS WITHOUT DAYTIME LIGHT SYSTEM

EL-F/FOG-03

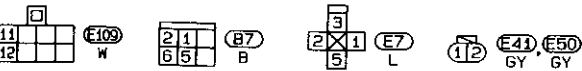
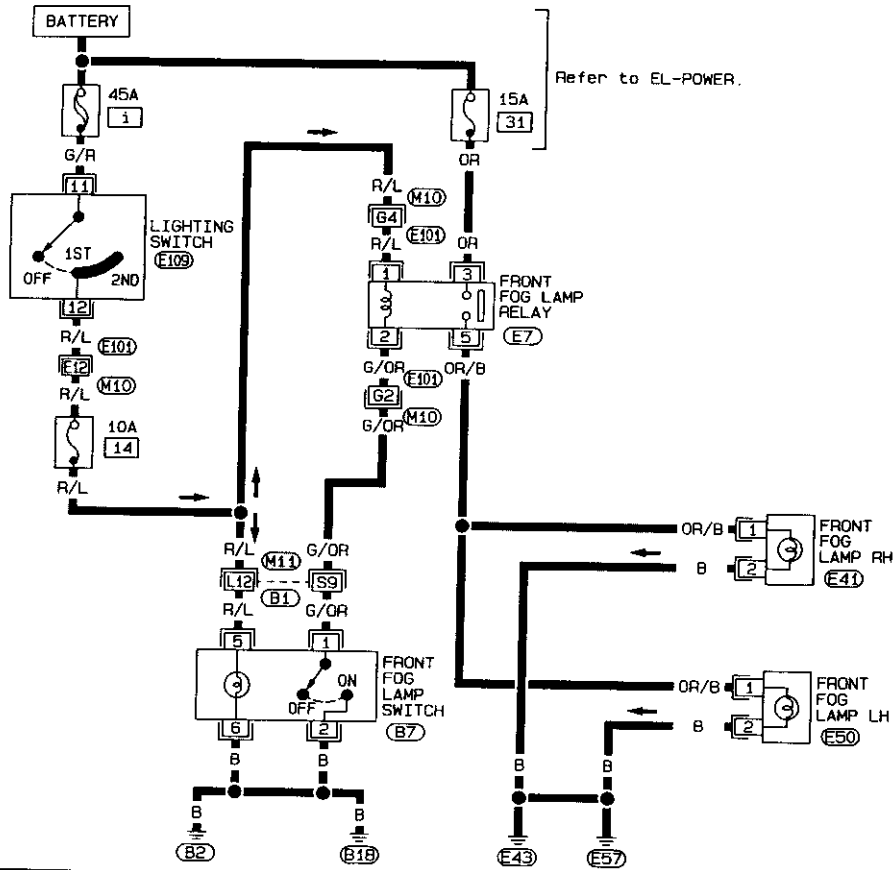

Refer to last page  
(Foldout page).

M10, E101  
M11, B1

SEL700T

EL-86

EXTERIOR LAMP

Front Fog Lamp/Wiring Diagram — F/FOG —  
(Cont'd)

RHD MODELS FOR EUROPE

EL-F/FOG-04

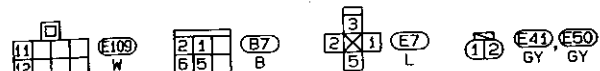
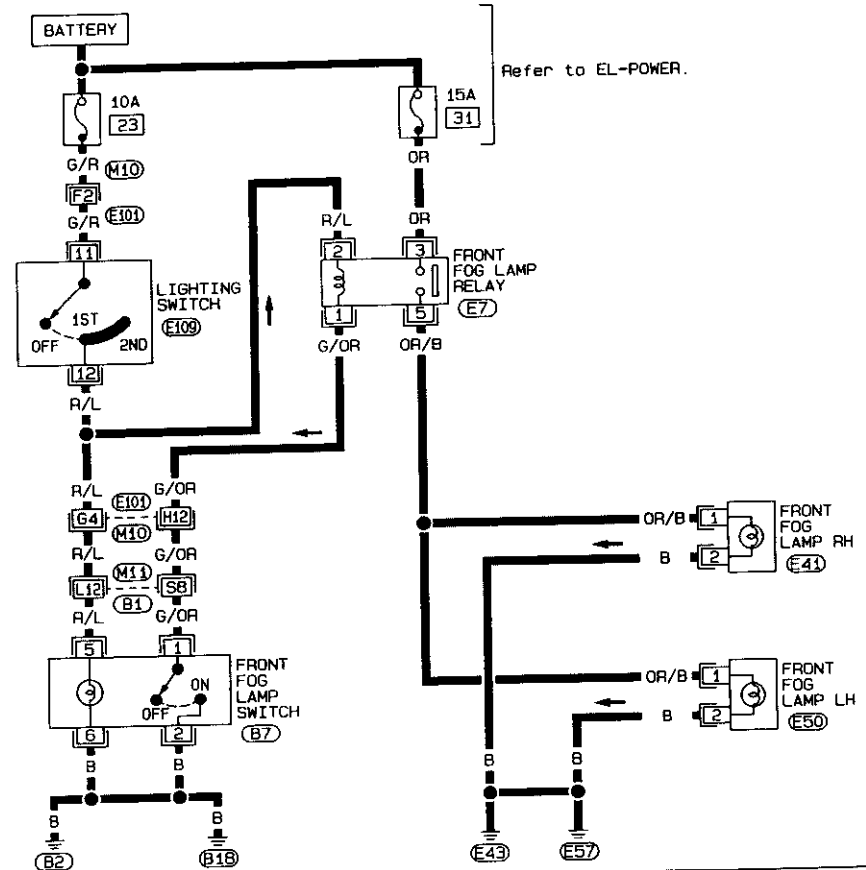

Refer to last page  
(Foldout page).

M10, E101  
M11, B1

SEL701T

EL-87

EL



## EXTERIOR LAMP

### Rear Fog Lamp/System Description

Power is supplied at all times

- through 7.5A fuse (No. 27 for LHD models, No. 29 for RHD models, located in the fuse block)
  - to rear fog lamp relay terminal 7 (with daytime light system) or 3 (without daytime light system)
- With the lighting switch in the 2ND position, power is supplied

- through 20A fuse (No. 37), located in the fusible link and fuse box)
- to lighting switch terminal 5
- through lighting switch terminal 25
- to rear fog lamp relay terminal 1.

### Rear fog lamp operation

The lighting switch must be in the 2ND position for rear fog lamp operation.

Ground is supplied to rear fog lamp relay terminal 2 through body ground (M1).

With the lighting switch in the 2nd position, the rear fog lamp relay is energized and power is supplied

- through rear fog lamp relay terminal 6 (with daytime light system) or 5 (without daytime light system)
- to rear fog lamp switch terminal 2.
- through rear fog lamp switch terminal 1
- to terminal 1 of rear fog lamp.

Ground is supplied to terminal 2 of rear fog lamp through body ground (T19).

With power and ground supplied, the rear fog lamp illuminates.

## EXTERIOR LAMP

### Rear Fog Lamp/Wiring Diagram — R/FOG —

#### WITH DAYTIME LIGHT SYSTEM

EL-R/FOG-01

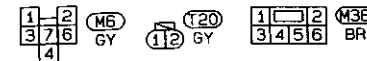
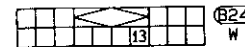
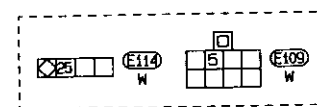
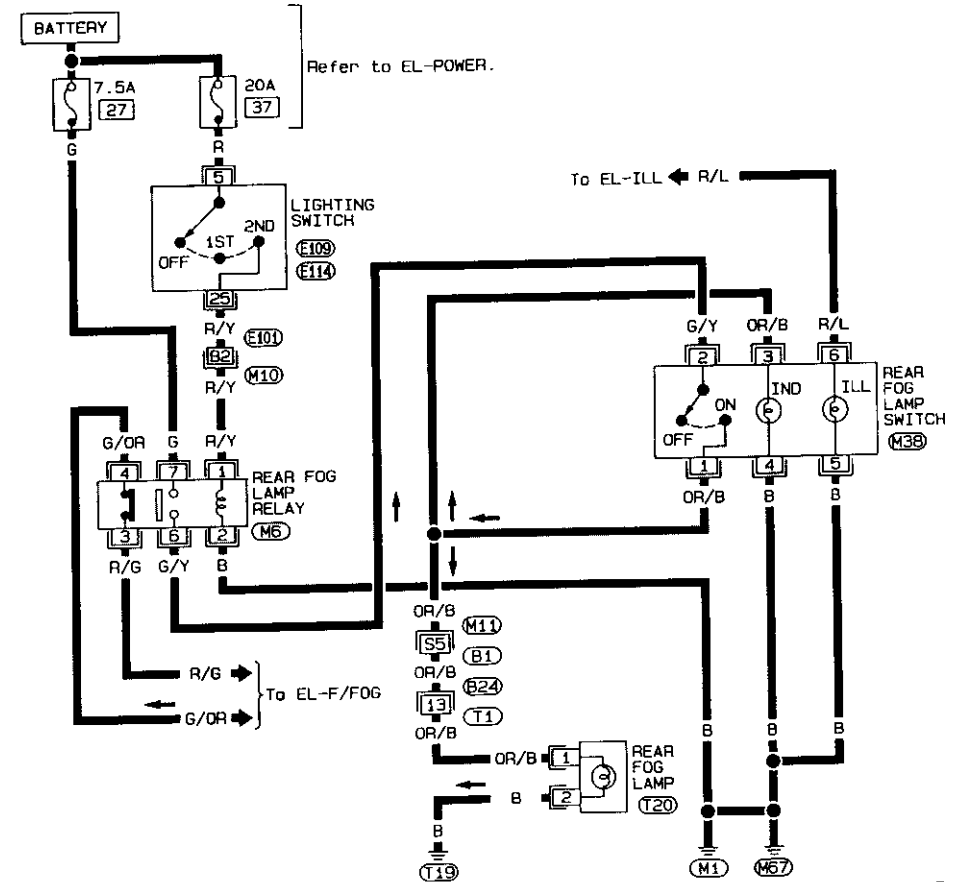

Refer to last page (Foldout page).

(M10), (E101)

(M11), (B1)

## EXTERIOR LAMP

### Rear Fog Lamp/Wiring Diagram — R/FOG — (Cont'd)

WITHOUT DAYTIME LIGHT SYSTEM

EL-R/FOG-02

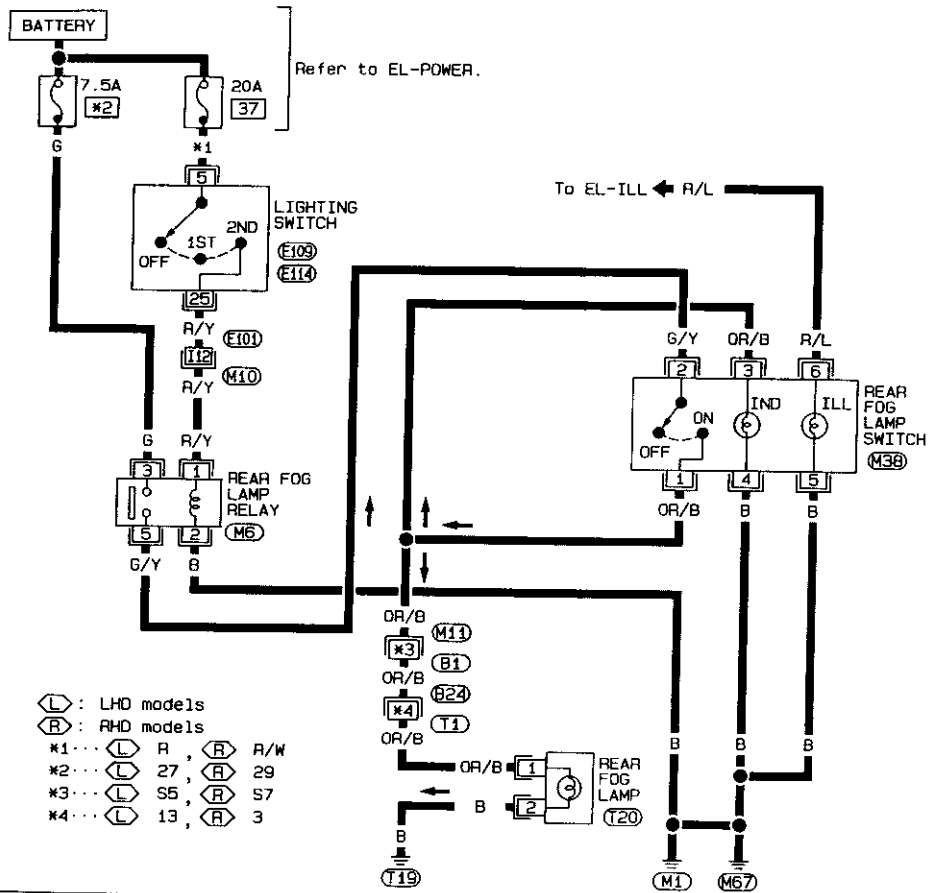

- ◁ : LHD models  
 ▷ : RHD models  
 \*1... ◁ R, ▷ R A/W  
 \*2... ◁ 27, ▷ 29  
 \*3... ◁ S5, ▷ S7  
 \*4... ◁ 13, ▷ 3

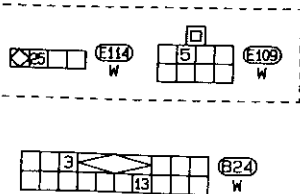

EL-92

SEL704T

## EXTERIOR LAMP

### Turn Signal and Hazard Warning Lamps/System Description

#### TURN SIGNAL OPERATION

With the hazard switch in the OFF position and the ignition switch in the ON or START position, power is supplied

- through 10A fuse (No. 24), located in the fuse block
- to hazard switch terminal ②
- through terminal ① of the hazard switch
- to combination flasher unit terminal ②
- through terminal ③ of the combination flasher unit
- to turn signal switch terminal ①

Ground is supplied to combination flasher unit terminal ① through body ground (M1) or (M67).

#### LH turn

When the turn signal switch is moved to the LH position, power is supplied from turn signal switch terminal ③ to

- front turn signal lamp LH terminal ①
- side turn signal lamp LH terminal ①
- rear combination lamp LH terminal ②
- combination meter terminal ⑱

Ground is supplied to the front turn signal lamp LH terminal ② through body ground (E57).

Ground is supplied to the side turn signal lamp LH terminal ② through body ground (E57) (LHD models) or (E31) (RHD models).

Ground is supplied to the rear combination lamp LH terminal ④ through body ground (T19).

Ground is supplied to combination meter terminal ⑱ through body ground (M1).

With power and ground supplied, the combination flasher unit controls the flashing of the LH turn signal lamps.

#### RH turn

When the turn signal switch is moved to the RH position, power is supplied from turn signal switch terminal ② to

- front turn signal lamp RH terminal ①
- side turn signal lamp RH terminal ①
- rear combination lamp RH terminal ②
- combination meter terminal ⑲

Ground is supplied to the front turn signal lamp RH terminal ② through body ground (E43).

Ground is supplied to the side turn signal lamp RH terminal ② through body ground (E26) (LHD models) or (E43) (RHD models).

Ground is supplied to the rear combination lamp RH terminal ④ through body ground (T19).

Ground is supplied to combination meter terminal ⑲ through body ground (M1).

With power and ground supplied, the combination flasher unit controls the flashing of the RH turn signal lamps.

#### HAZARD LAMP OPERATION

Power is supplied at all times to hazard switch terminal ③ through:

- 10A fuse (No. 22), located in the fuse block.
- With the hazard switch in the ON position, power is supplied
- through terminal ① of the hazard switch
- to combination flasher unit terminal ②
- through terminal ③ of the combination flasher unit
- to hazard switch terminal ④

Ground is supplied to combination flasher unit terminal ① through body ground (M1) or (M67).

Power is supplied through terminal ⑤ of the hazard switch to

- front turn signal lamp LH terminal ①
- side turn signal lamp LH terminal ①
- rear combination lamp LH terminal ②
- combination meter terminal ⑱

Power is supplied through terminal ⑥ of the hazard switch to

EL-93

GI  
 MA  
 EM  
 LC  
 EC  
 RE  
 CL  
 MT  
 AT  
 FT  
 E2  
 RE  
 BE  
 ST  
 HA  
 EL  
 FOX

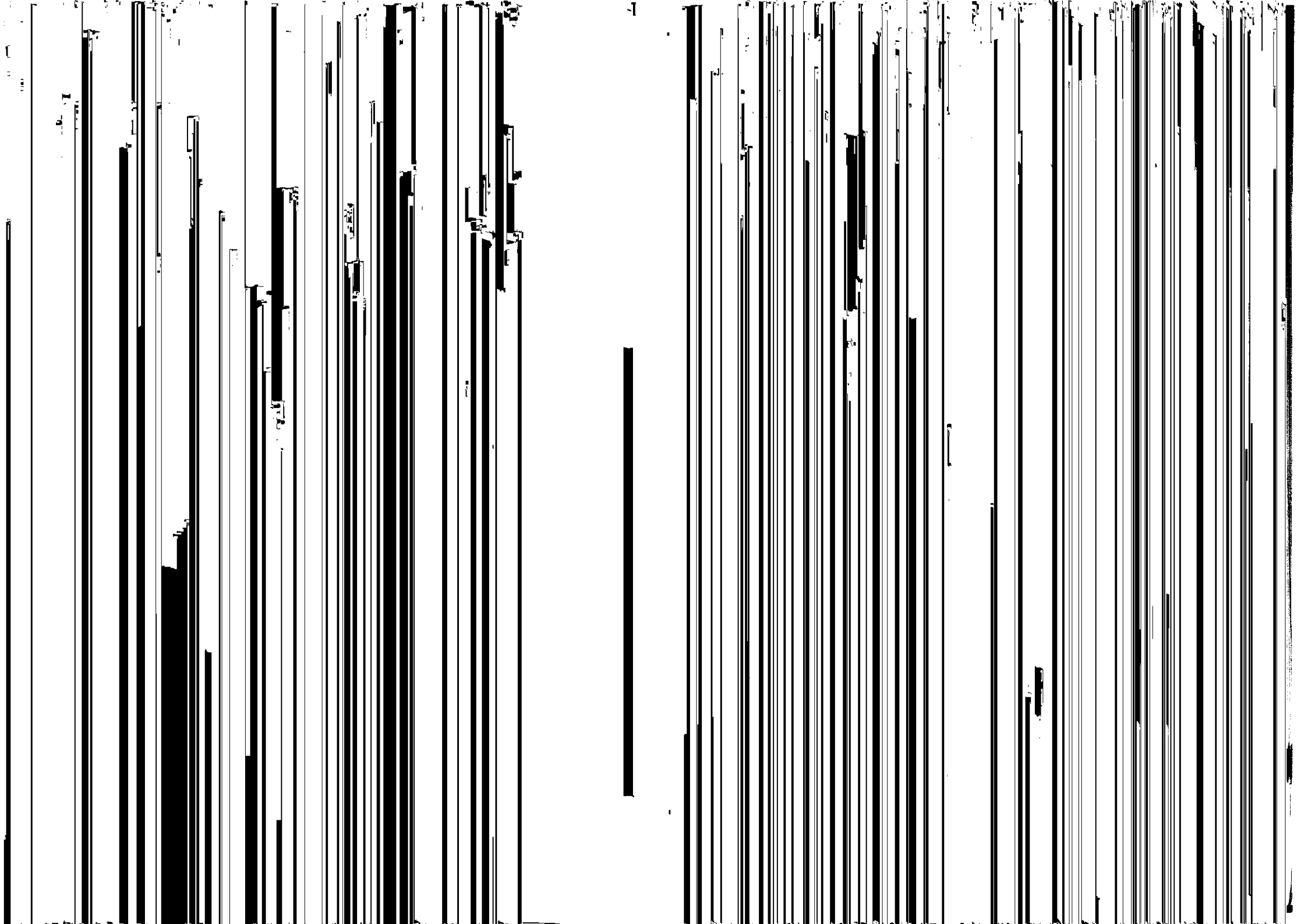

# EXTERIOR LAMP

## Turn Signal and Hazard Warning Lamps/Wiring Diagram — TURN —

LHD MODELS

EL-TURN-01

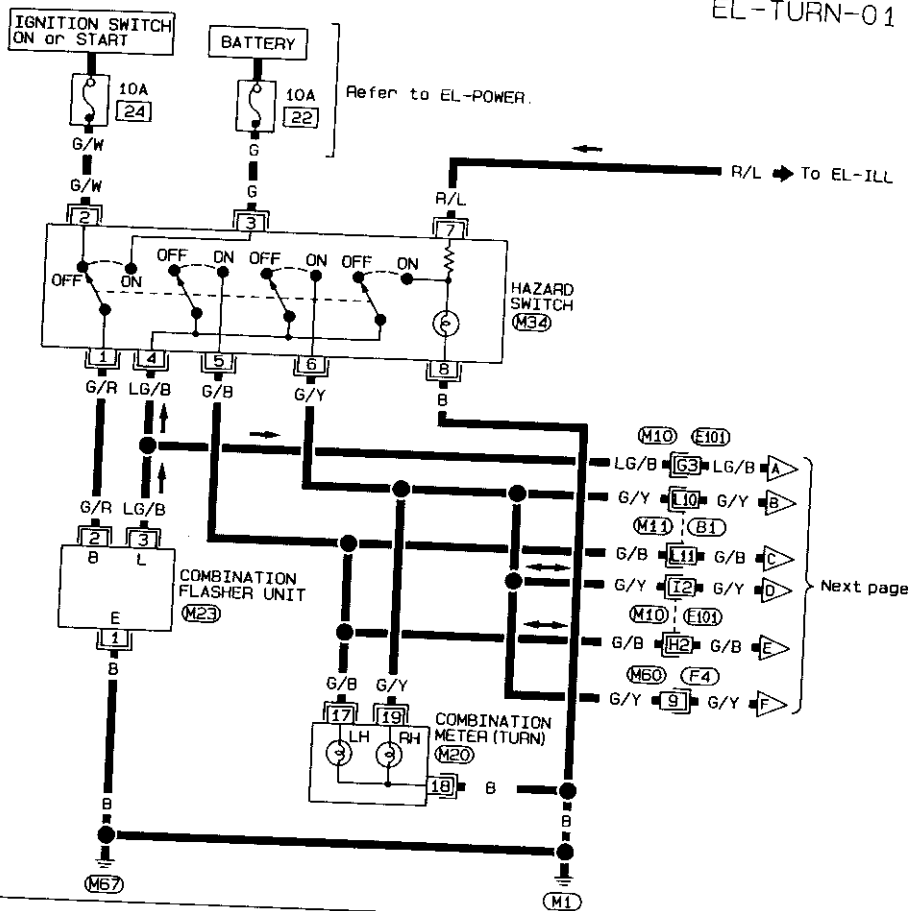

Next page

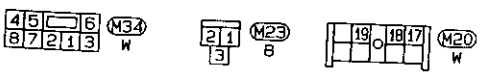

Refer to last page (Foldout page).

M10, E10  
M11, B1  
M50, F4

# EXTERIOR LAMP

## Turn Signal and Hazard Warning Lamps/Wiring Diagram — TURN — (Cont'd)

EL-TURN-02

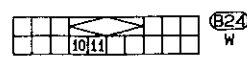
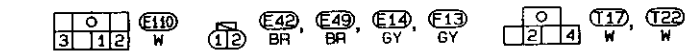
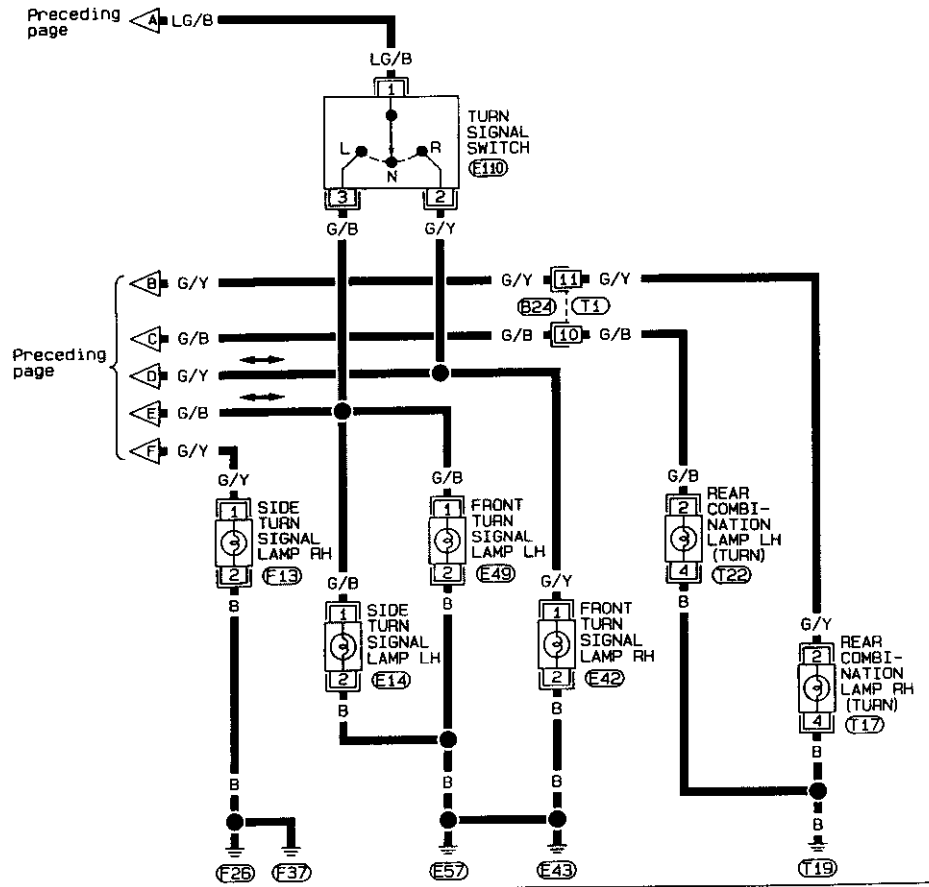



## EXTERIOR LAMP Turn Signal and Hazard Warning Lamps/Wiring Diagram — TURN — (Cont'd)

RHD MODELS

EL-TURN-03

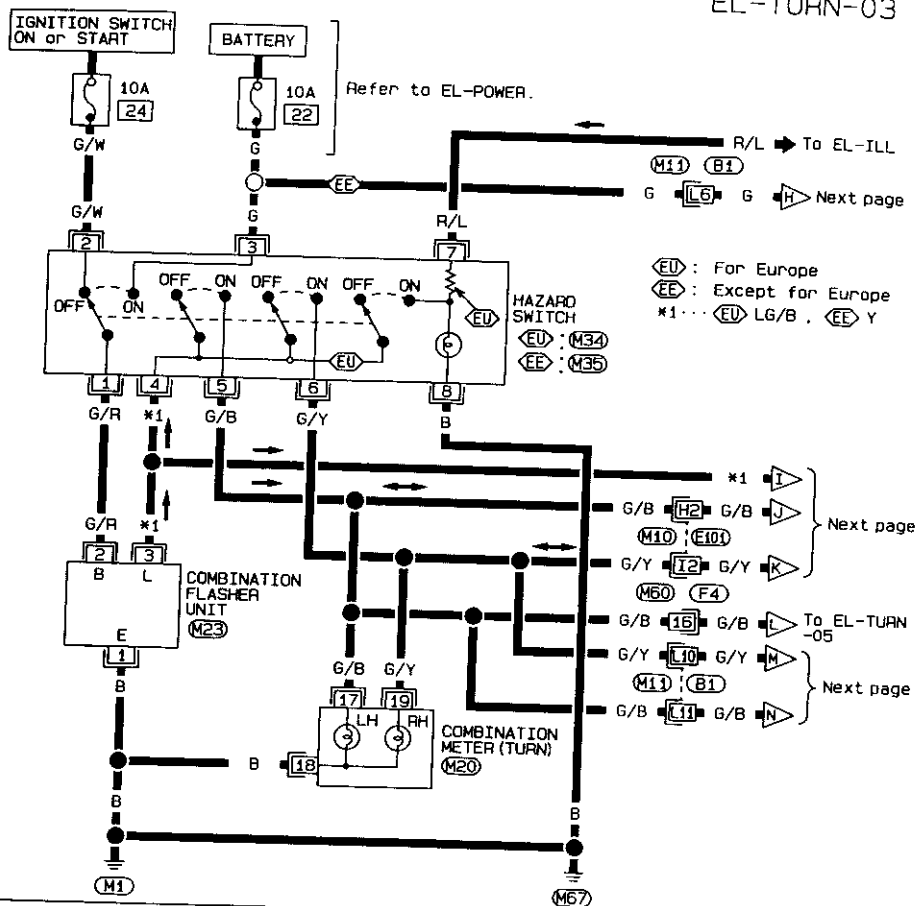

EU : For Europe  
 EE : Except for Europe  
 \*1... EU LG/B, EE Y

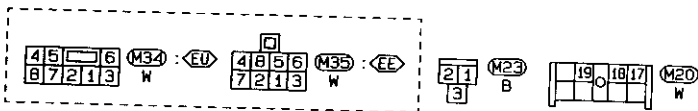

Refer to last page (Foldout page).  
 M10, E101  
 M11, B1  
 M60, F4

## EXTERIOR LAMP Turn Signal and Hazard Warning Lamps/Wiring Diagram — TURN — (Cont'd)

EL-TURN-04

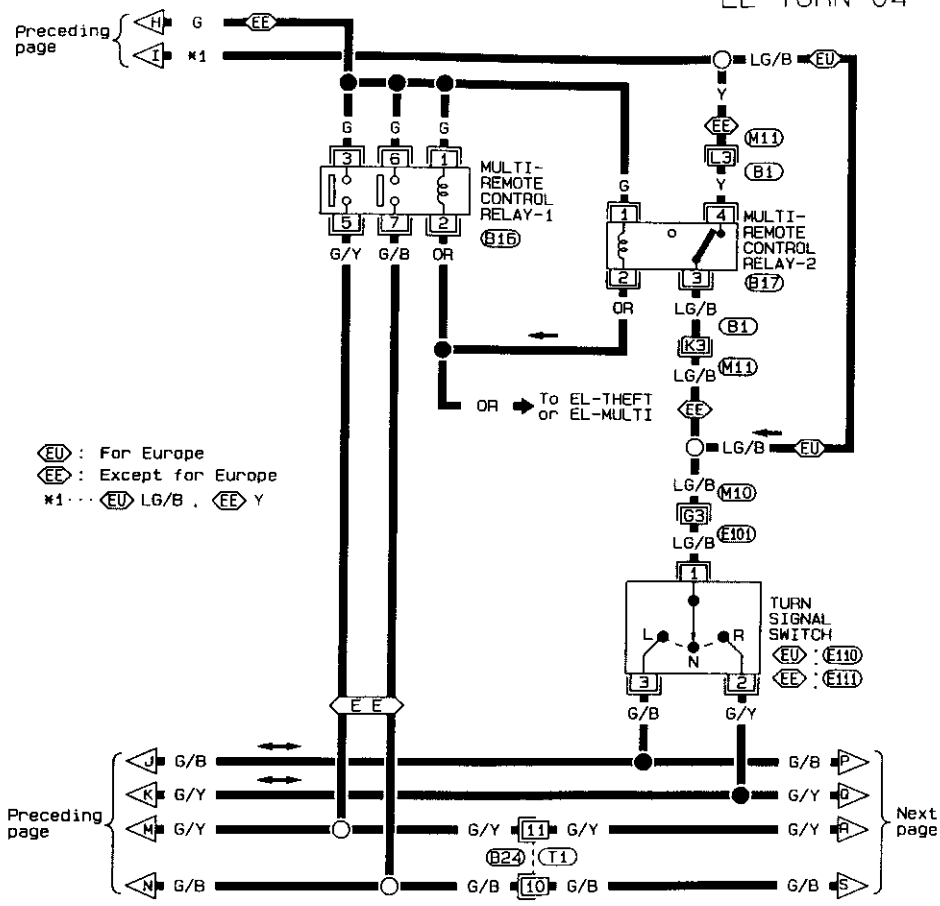

EU : For Europe  
 EE : Except for Europe  
 \*1... EU LG/B, EE Y

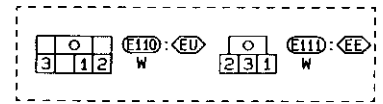

Refer to last page (Foldout page).  
 M10, E101  
 M11, B1

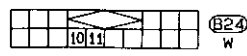



## EXTERIOR LAMP

### Bulb Specifications

Item	Wattage (W)
Front fog lamp	55
Front turn signal lamp	21
Clearance lamp	5
Side turn signal lamp	5
Rear combination lamp	
Turn signal lamp	21
Stop/Tail lamp	21/5
Back-up lamp	21
License plate lamp	5
Rear fog lamp	21
High-mounted stop lamp	5

## INTERIOR LAMP

### Illumination/System Description

Power supply routing for illumination lamps are the same as that of clearance, license and LH tail lamp. Refer to "Clearance, License and Tail Lamps".

On vehicles for Europe and Australia, illumination of combination meter and clock is controlled by illumination control switch.

The illumination control switch that controls the amount of current to the illumination system. As the amount of current increases, the illumination becomes brighter.

The following chart shows the power and ground connector terminals for the components included in the illumination system.

Component	Connector No.	Power terminal	Ground terminal	Ground
Audio	M40	8	— (Unit ground)	—
Push control unit	M32	15	16	(M1) or (M67)
Auto A/C unit	M31	13	14	(M1) or (M67)
A/T indicator	B8	7	6	(B2) or (B18)
Power window main switch	D9	15	16	(M1) or (M67)
Cigarette lighter	M42	3	1	(M1) or (M67)
Combination meter	M20	6	33	(*)
Clock	M20	8	33	(*)
Hazard switch (For Europe)	M34	7	8	(M1) or (M67)
Hazard switch (Except for Europe)	M35	7	8	(M1) or (M67)
Glove box lamp (switch)	M103	2	1	(M1) or (M67)
Front fog lamp switch	B7	5	6	(B2) or (B18)
Rear fog lamp switch	M38	6	5	(M1) or (M67)
Headlamp washer switch	M36	4	3	(M1) or (M67)
Rear window defogger switch	M37	5	6	(M1) or (M67)
Illumination control switch	M21	1	3	(M1) or (M67)

\*1: For Europe and Australia models ... Illumination control switch  
 Except for Europe and Australia models ... (M1) or (M67)

# INTERIOR LAMP

## Illumination/Schematic

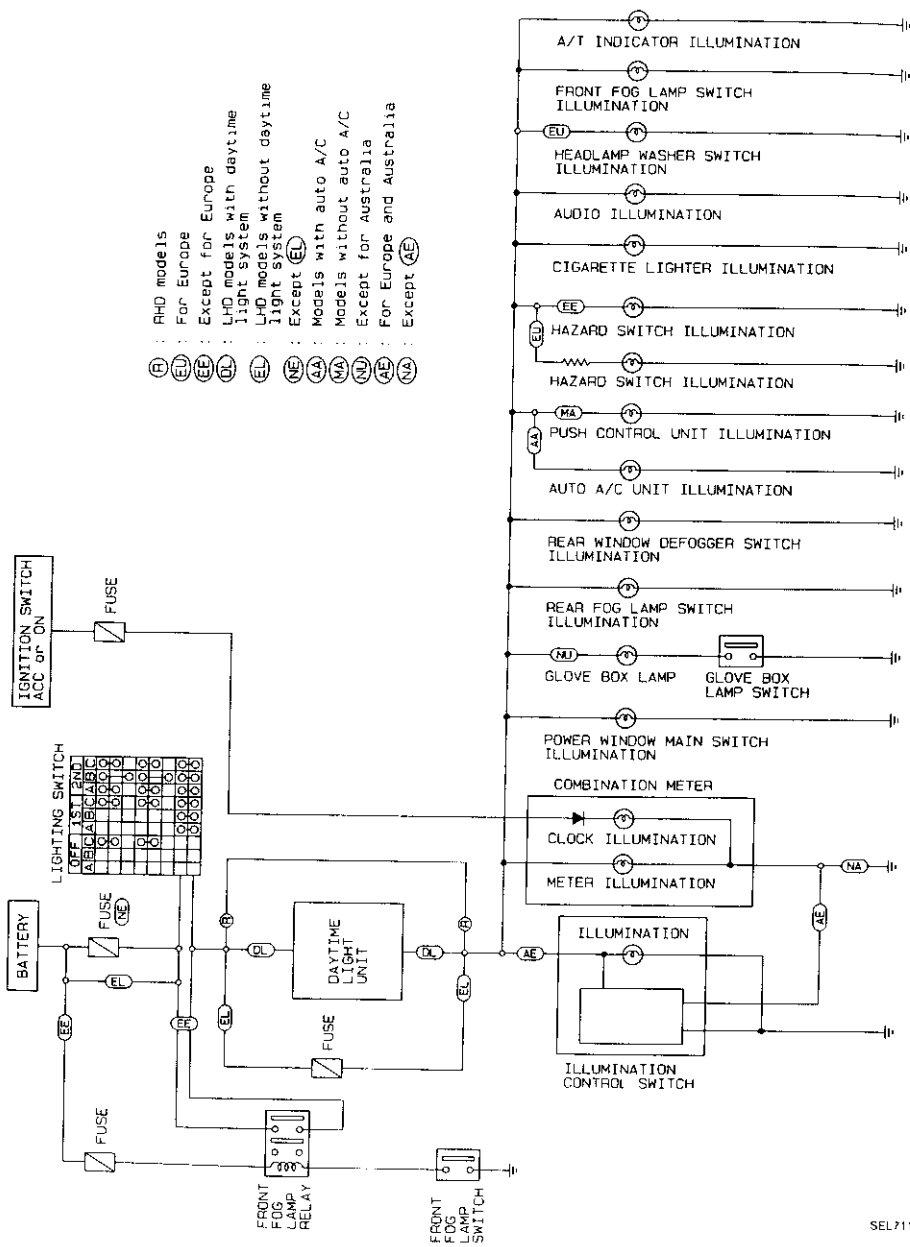

- (R) : RHD models
- (EU) : For Europe
- (EE) : Except for Europe
- (EL) : LHD models with daytime light system
- (NE) : LHD models without daytime light system
- (AE) : Except (EL)
- (AA) : Models with auto A/C
- (MA) : Models without auto A/C
- (NU) : Except for Australia
- (AF) : For Europe and Australia
- (NA) : Except (AE)

# INTERIOR LAMP

## Illumination/Wiring Diagram — ILL —

EL-ILL-01

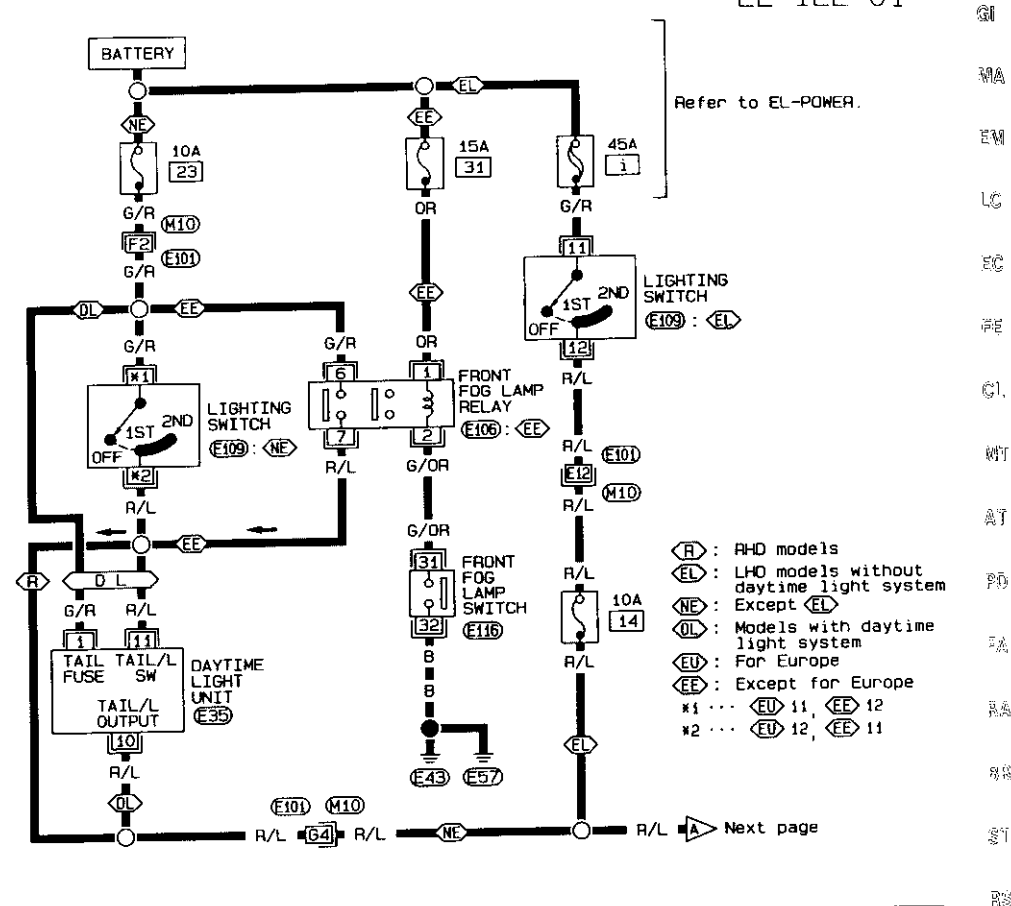

Refer to EL-POWER.

- (R) : RHD models
- (EL) : LHD models without daytime light system
- (NE) : Except (EL)
- (DL) : Models with daytime light system
- (EU) : For Europe
- (EE) : Except for Europe
- \*1 ... (EU) 11, (EE) 12
- \*2 ... (EU) 12, (EE) 11

Next page

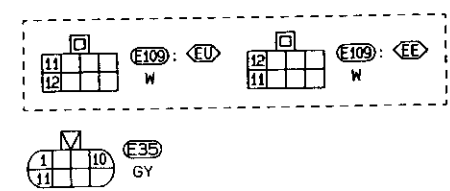

Refer to last page (Foldout page).

(M10), (E101)

**INTERIOR LAMP**  
Illumination/Wiring Diagram — ILL — (Cont'd)

EL-ILL-02

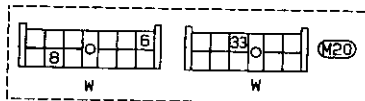
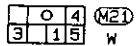
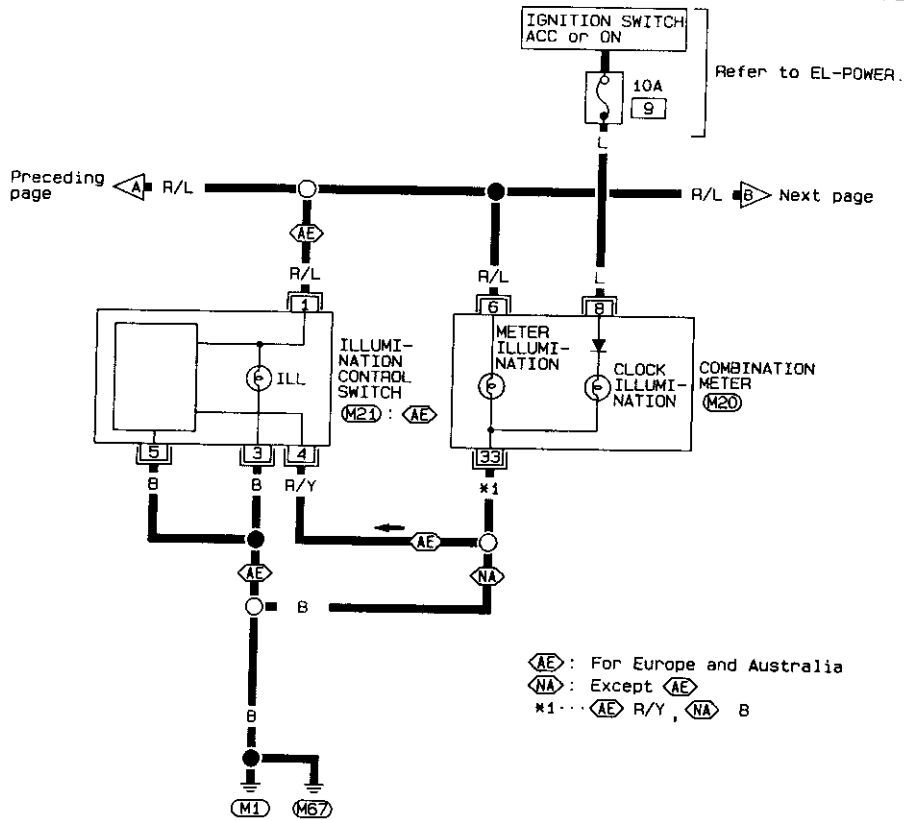

EL-106

SEL713T

**INTERIOR LAMP**  
Illumination/Wiring Diagram — ILL — (Cont'd)

EL-ILL-03

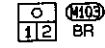
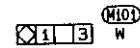
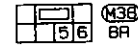
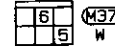
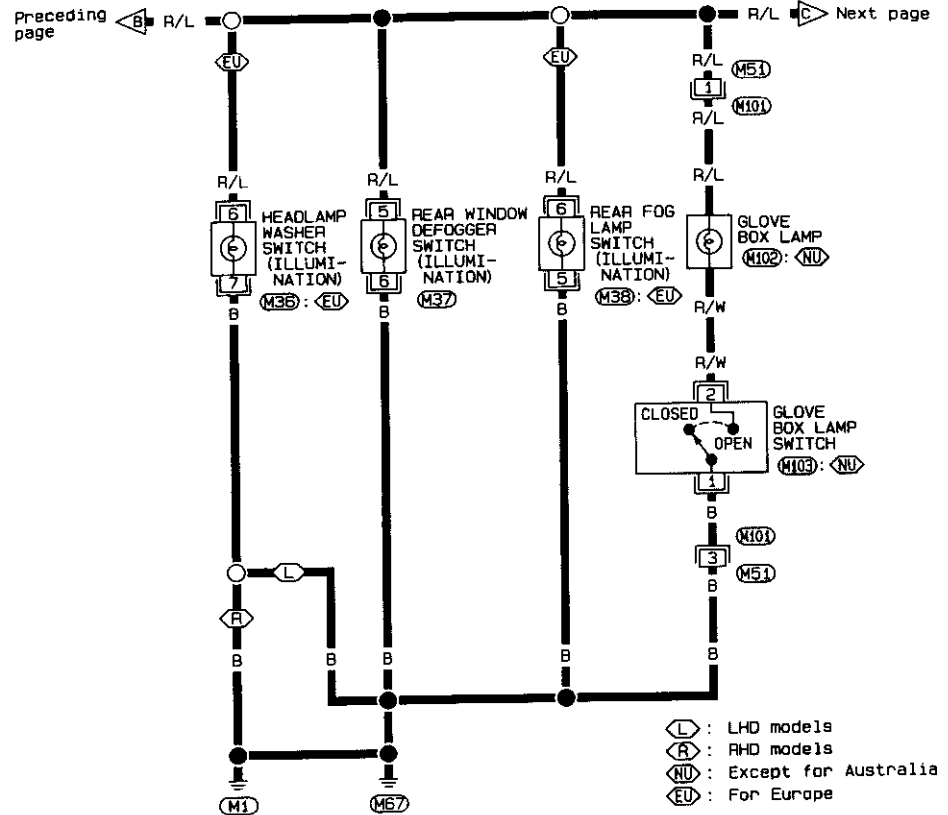

EL-107

SEL714T

EL

IOX

INTERIOR LAMP  
Illumination/Wiring Diagram — ILL — (Cont'd)

EL-ILL-04

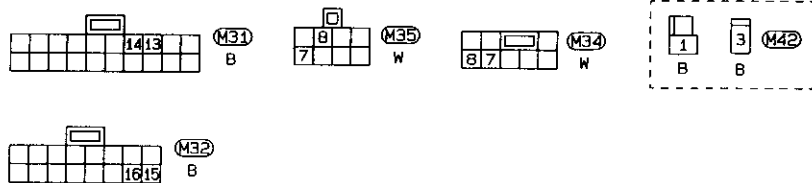
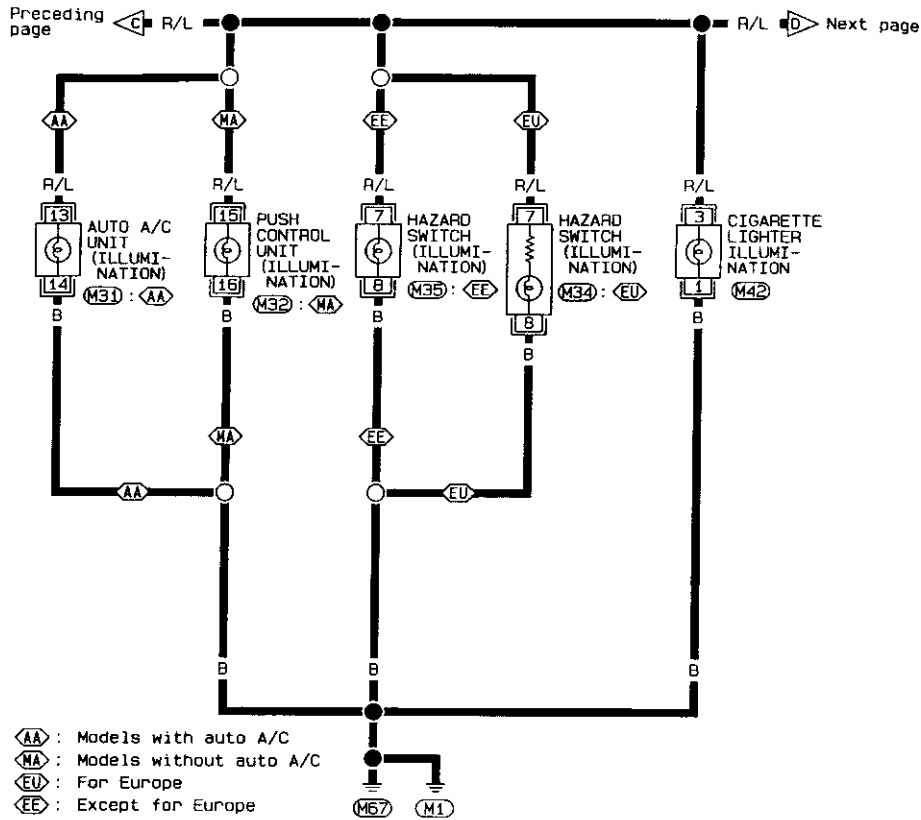

EL-108

SEL715T

INTERIOR LAMP  
Illumination/Wiring Diagram — ILL — (Cont'd)

EL-ILL-05

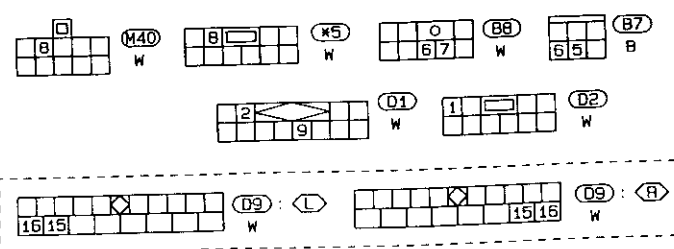
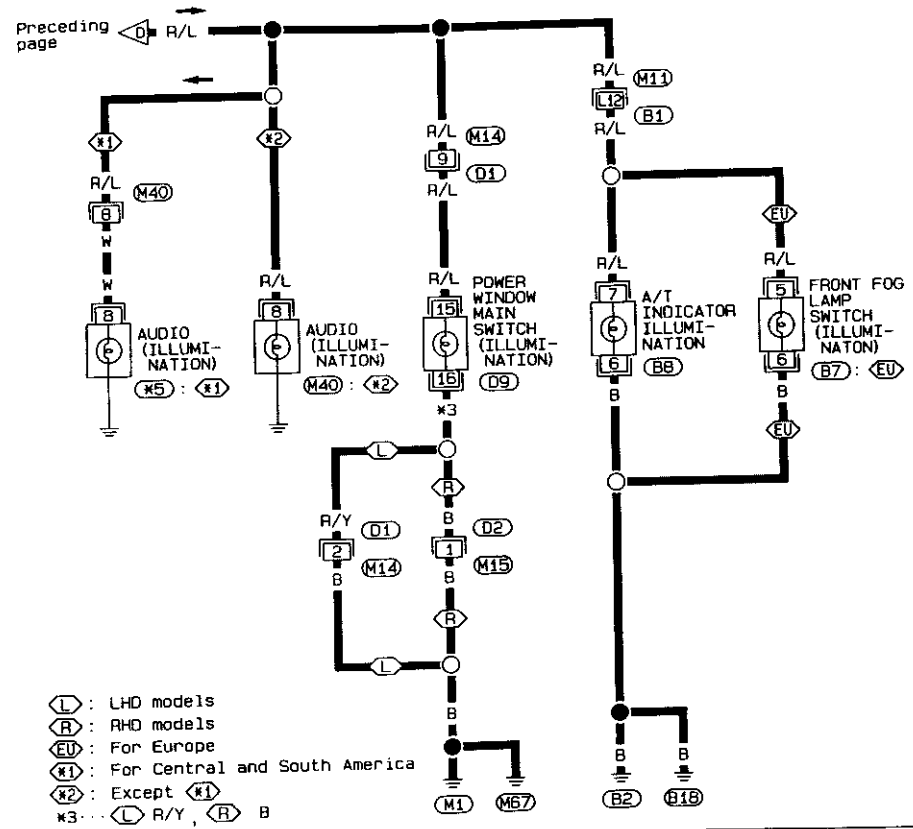

Refer to last page  
(Foldout page).

M11, B1

EL-109

SEL716T

## INTERIOR LAMP

### Interior, Spot and Trunk Room Lamps/System Description

Power is supplied at all times

- through 10A fuse (No. 21) located in the fuse block
- to interior lamp terminal ①.
- to spot lamp terminal ① and
- to trunk room lamp terminal ①.

## INTERIOR LAMP

### Switch operation

With interior lamp switch in the ON position, ground is supplied to turn interior lamp on.

When a door switch is set to OPEN with interior lamp switch in the DOOR position, ground is supplied

- to interior lamp terminal ②
- through diode (M43) terminal ① (Except for Europe models)
- to diode (M43) terminal ② (Except for Europe models)
- through diode (M44) terminal ① (Except for Europe models)
- to diode (M44) terminal ② (Except for Europe models)
- through door switch passenger side terminal ① or
- through door switch driver's side terminal ②,
- through door switch unit ground.

### Interior lamp control by multi-remote control system

When the smart entrance control unit receives a signal from multi-remote controller to unlock the door with interior lamp switch set in DOOR position, ground is supplied

- to interior lamp terminal ②
- through smart entrance control unit terminal ⑨,
- through smart entrance control unit terminal ⑩ and
- through body ground (M1).

With power and ground supplied, the interior lamp illuminates.

For smart entrance control unit, refer to "MULTI-REMOTE CONTROL SYSTEM".

## TRUNK ROOM LAMP

When the trunk room lamp switch is set to OPEN, ground is supplied

- to trunk room lamp terminal ②
- through trunk room switch terminal ①,
- through trunk room lamp switch terminal ② and
- through body ground (T19).

With power and ground supplied, the trunk room lamp illuminates.

## SPOT LAMP

With the spot lamp switch in the ON position, ground is supplied

- to spot lamp terminal ②
- through body ground (M1) or (M67).

With power and ground supplied, the spot lamp illuminates.

### Bulb Specifications

Item	Wattage (W)
Interior lamp	10
Spot lamp	10
Trunk room lamp	3.4

## INTERIOR LAMP

### Interior, Spot and Trunk Room Lamps/Wiring Diagram — INT/L —

#### LHD MODELS

EL-INT/L-01

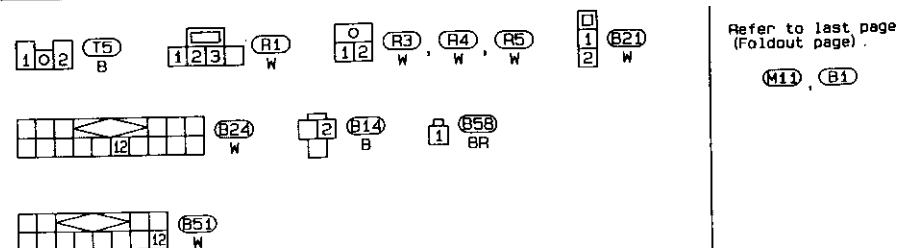
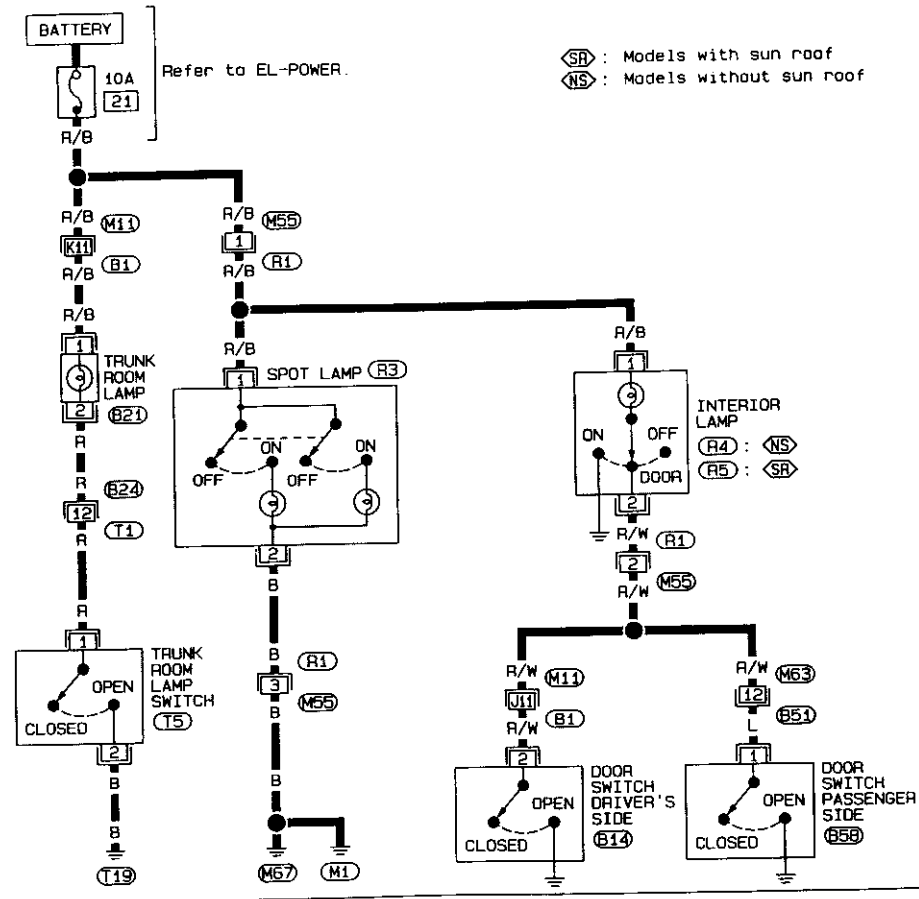

## INTERIOR LAMP

### Interior, Spot and Trunk Room Lamps/Wiring Diagram — INT/L — (Cont'd)

RHD MODELS

EL-INT/L-02

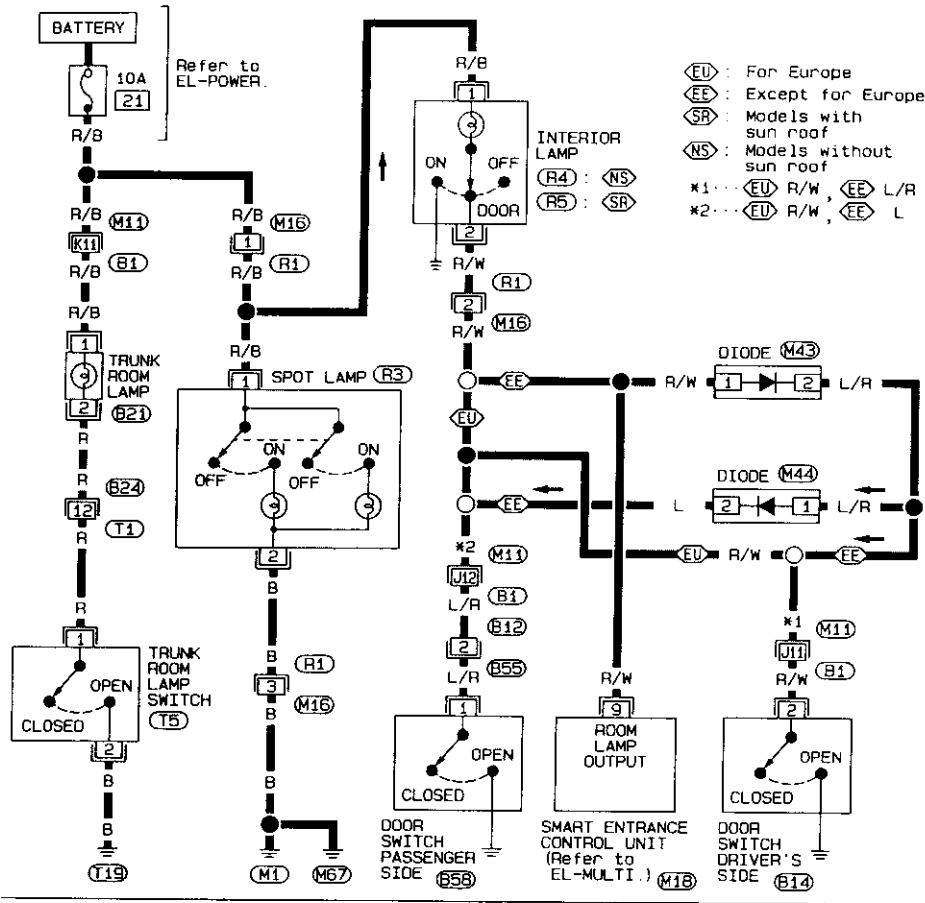

- ⓔⓤ : For Europe
- ⓔⓔ : Except for Europe
- ⓈⓇ : Models with sun roof
- ⓃⓈ : Models without sun roof
- \*1... ⓔⓤ R/W, ⓔⓔ L/R
- \*2... ⓔⓤ R/W, ⓔⓔ L
- ⓇⓇ : ⓃⓈ
- ⓇⓇ : ⓈⓇ

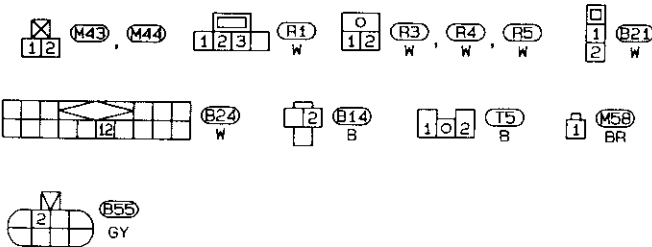

Refer to last page (Foldout page).

- ⓇⓇ, ⓇⓇ
- ⓇⓇ

SEL816T

## METER AND GAUGES

### System Description

With the ignition switch in the ON or START position, power is supplied

- through 7.5A fuse (No. 25) located in the fuse block
- to combination meter terminal ②.

Ground is supplied

- to combination meter terminal ②
- through body ground (MT).

### WATER TEMPERATURE GAUGE

The water temperature gauge indicates the engine coolant temperature. The reading on the gauge is based on the resistance of the thermal transmitter.

As the temperature of the coolant increases, the resistance of the thermal transmitter decreases. A variable ground is supplied to terminal ③ of the combination meter for the water temperature gauge. The needle on the gauge moves from "C" to "H".

### TACHOMETER

The tachometer indicates engine speed in revolutions per minute (rpm).

The tachometer is regulated by a signal

- from terminal ⑦ of the ECM (ECCS control module)
- to combination meter terminal ⑫ for the tachometer.

### FUEL GAUGE

The fuel gauge indicates the approximate fuel level in the fuel tank.

The fuel gauge is regulated by a variable ground signal supplied

- to combination meter terminal ⑩ for the fuel gauge
- from terminal ① of the fuel tank gauge unit
- through terminal ③ of the fuel tank gauge unit and
- through body grounds (T19, B2) and (B18).

### SPEEDOMETER

The vehicle speed sensor provides a voltage signal to the combination meter for the speedometer.

The voltage is supplied

- to combination meter terminals ④ and ⑤ for the speedometer
- from terminals ① and ② of the vehicle speed sensor.

The speedometer converts the voltage into the vehicle speed displayed.

EL



## METER AND GAUGES

### Inspection/Fuel Gauge and Water Temperature Gauge

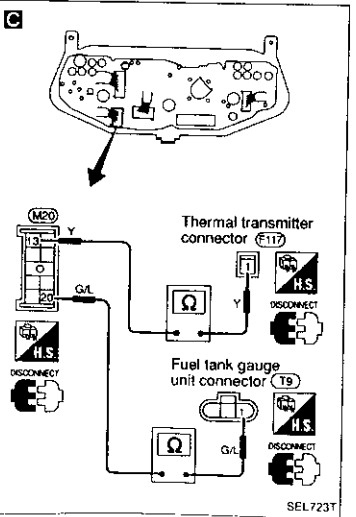
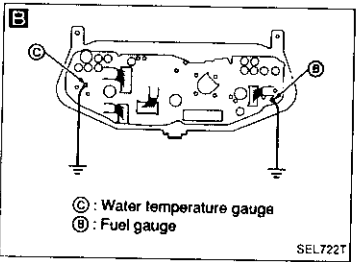
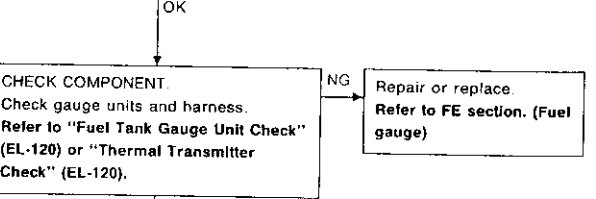
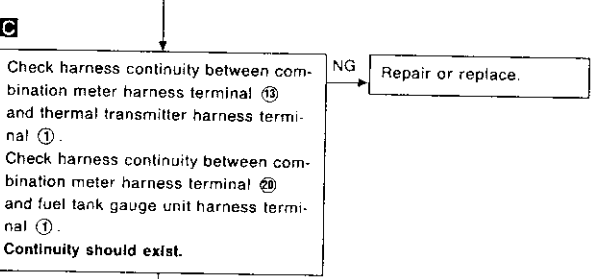
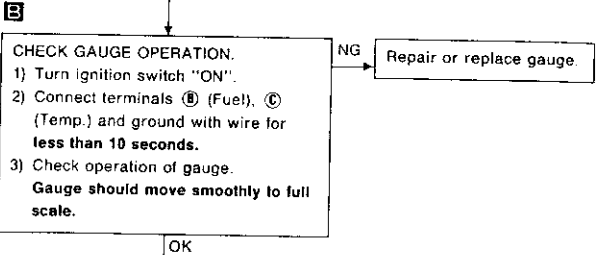
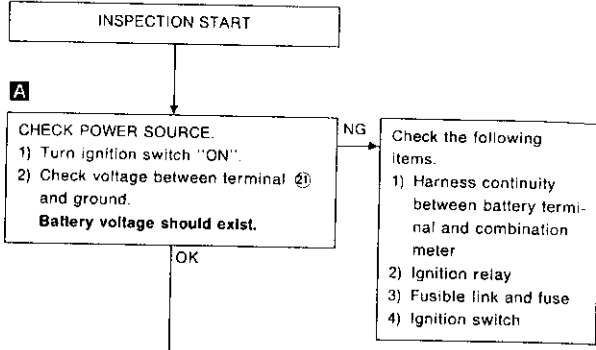
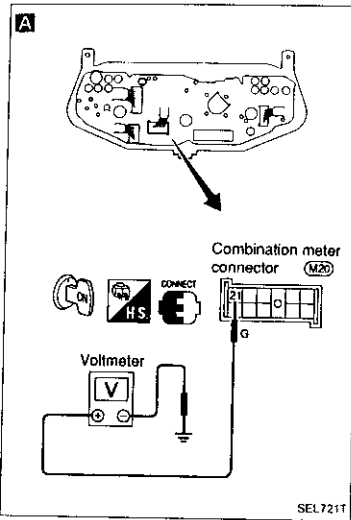

## METER AND GAUGES

### Inspection/Fuel Gauge and Water Temperature Gauge (Cont'd)

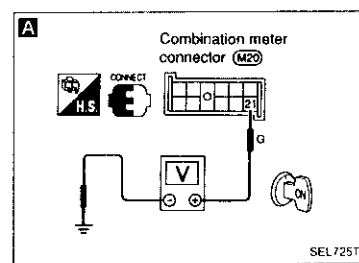
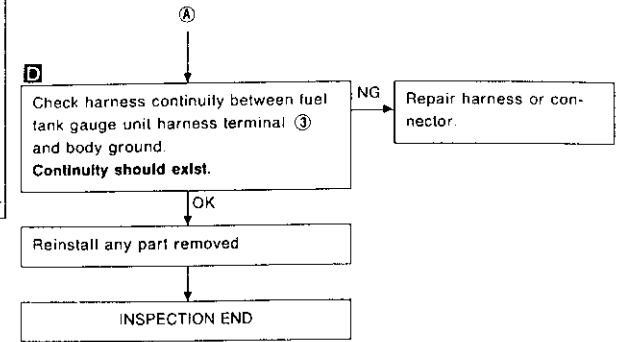
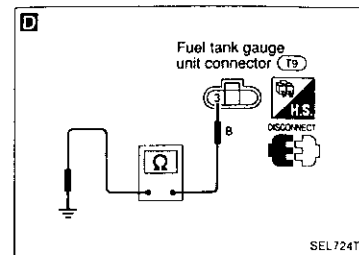

### Inspection/Tachometer

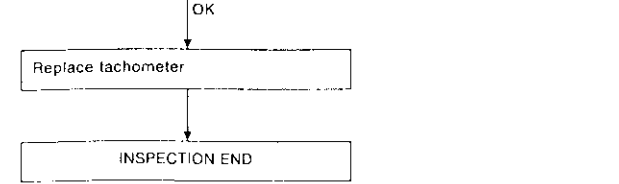
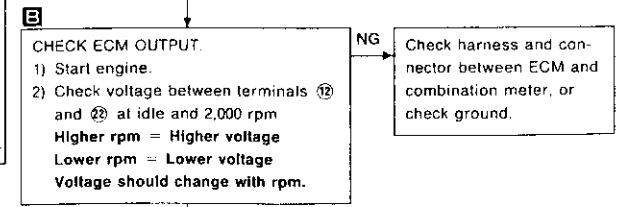
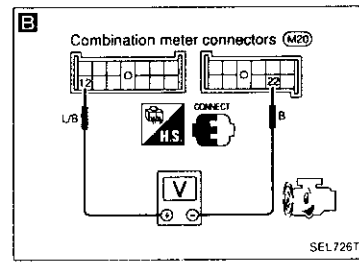
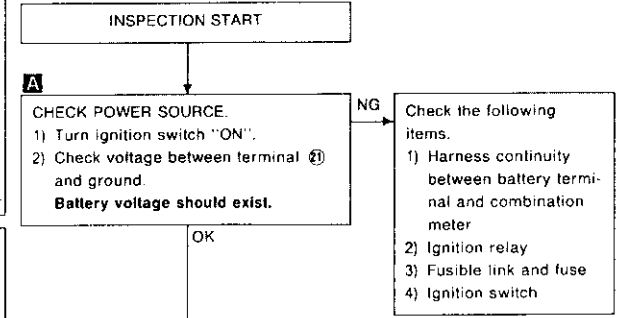

## METER AND GAUGES

### Inspection/Speedometer and Vehicle Speed Sensor

**SYMPTOM:** Speedometer stays at 0 km/h (0 MPH).

INSPECTION START

**A** CHECK GROUND CIRCUIT OF SPEEDOMETER.  
Check continuity between terminal ② and body ground.  
**Continuity should exist.**

NG → Repair harness or connector.

**B** CHECK SPEEDOMETER CIRCUIT.  
1) Turn ignition switch "ON".  
2) Check voltage between terminal ① and body ground.  
**Battery voltage should exist.**

NG → Repair harness or connector.

**C** CHECK VEHICLE SPEED SENSOR OUTPUT.  
1) Remove vehicle speed sensor from transaxle.  
2) Check voltage between terminal ② and ③ while quickly turning speed sensor pinion.  
**Voltage: Approx. 0.5V**

OK → Replace speedometer.

**D** CHECK VEHICLE SPEED SENSOR.  
Check resistance between terminals ① and ②.  
**Resistance: Approx. 250Ω.**

NG → Replace vehicle speed sensor.

OK → Repair harness or connector between speedometer and vehicle speed sensor.

INSPECTION END

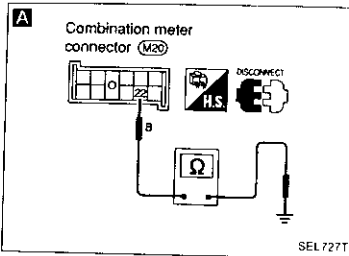

SEL727T

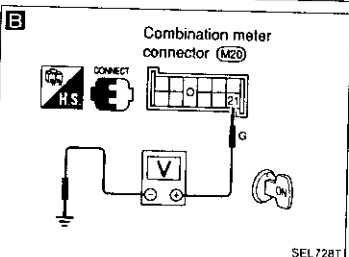

SEL728T

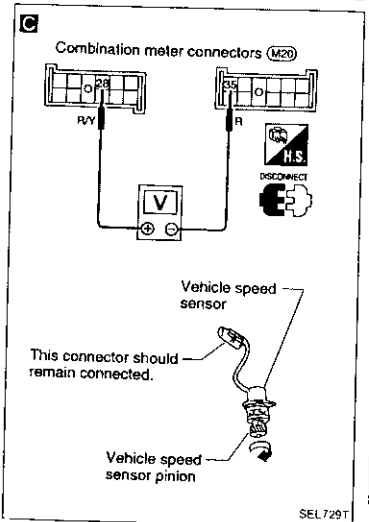

SEL729T

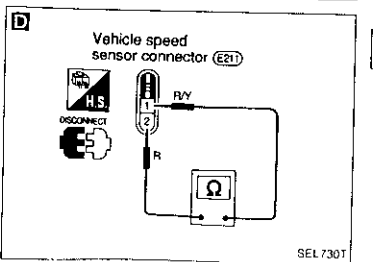

SEL730T

## METER AND GAUGES

### Inspection/Speedometer and Vehicle Speed Sensor (Cont'd)

**SYMPTOM:** Speedometer indication flutters.

INSPECTION START

Is vehicle speed sensor installed properly? Check looseness and so on.

NG → Install vehicle speed sensor properly.

**A** Do you feel resistance when turning vehicle speed sensor pinion?

No → Replace vehicle speed sensor.

**B** Check continuity between speedometer terminal ② and vehicle speed sensor terminal ①, and between ③ and ②.  
**Continuity should exist.**

NG → Repair harness and connector.

OK → Replace speedometer.

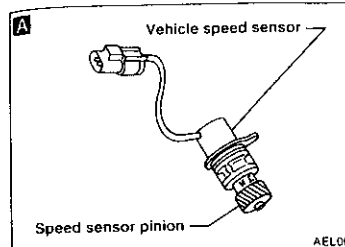

AEL061

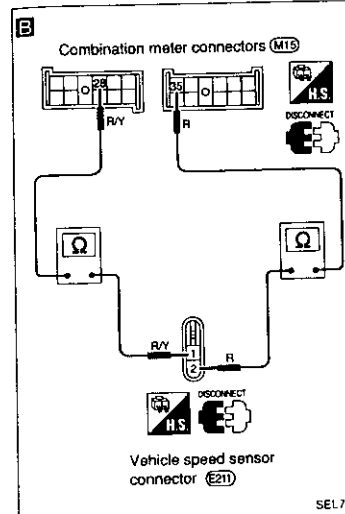

SEL731T

## METER AND GAUGES

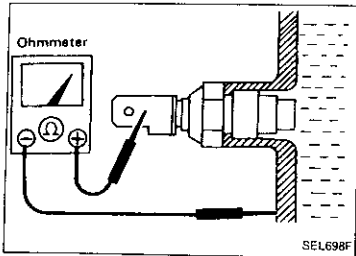

### Thermal Transmitter Check

Check the resistance between the terminals of thermal transmitter and body ground.

Water temperature	Resistance
60°C (140°F)	Approx. 70 - 90Ω
100°C (212°F)	Approx. 21 - 24Ω

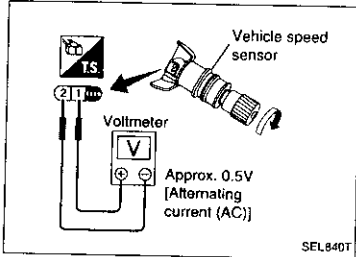

### Vehicle Speed Sensor Signal Check

1. Remove vehicle speed sensor from transmission.
2. Turn vehicle speed sensor pinion quickly and measure voltage across ① and ②.

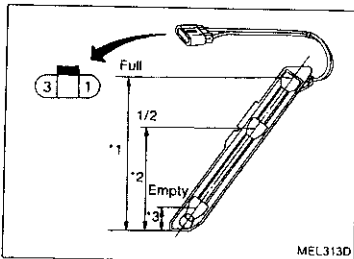

### Fuel Tank Gauge Unit Check

#### Sending unit

- For removal, refer to FE section.

Check the resistance between terminals ① and ③.

Ohmmeter (+)	Ohmmeter (-)	Float position mm (in)		Resistance value (Ω)
		*1	*2	
①	③	*1	Full	358 (14.09)
		*2	1/2	245 (9.65)
		*3	Empty	42 (1.65)

\*1 and \*3: When float is in contact with stopper.

## METER AND GAUGES

### Lead Switch

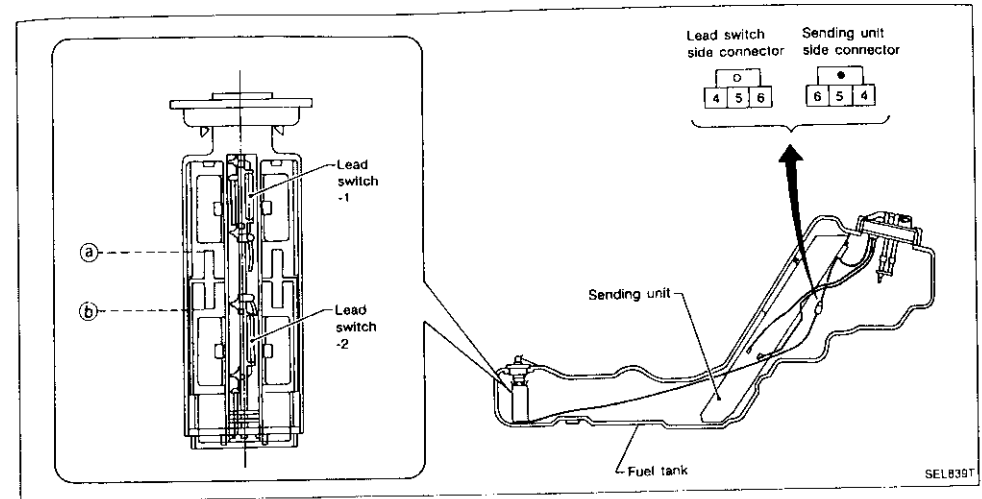

Lead switch is built into the fuel tank.

Check the continuity between terminals ④ and ⑤ or ④ and ⑥.

Terminals			Lead switch condition		Fuel level line	Fuel capacity (Approximate values) ? (Imp qt)
④	⑤	⑥	SW1	SW2		
○	○	○	ON	ON	Above ①	More than 6.8 (6)
○	○	○	OFF	ON	③ - ⑥	2.5 - 6.8 (2-1/4 - 6)
○	○	○	OFF	OFF	Below ⑥	Less than 2.5 (2-1/4)



# WARNING LAMPS AND BUZZER

## Warning Lamps/Wiring Diagram — WARN — (Cont'd)

EL-WARN-03

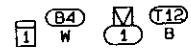
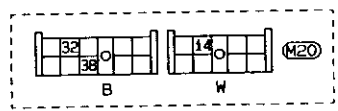
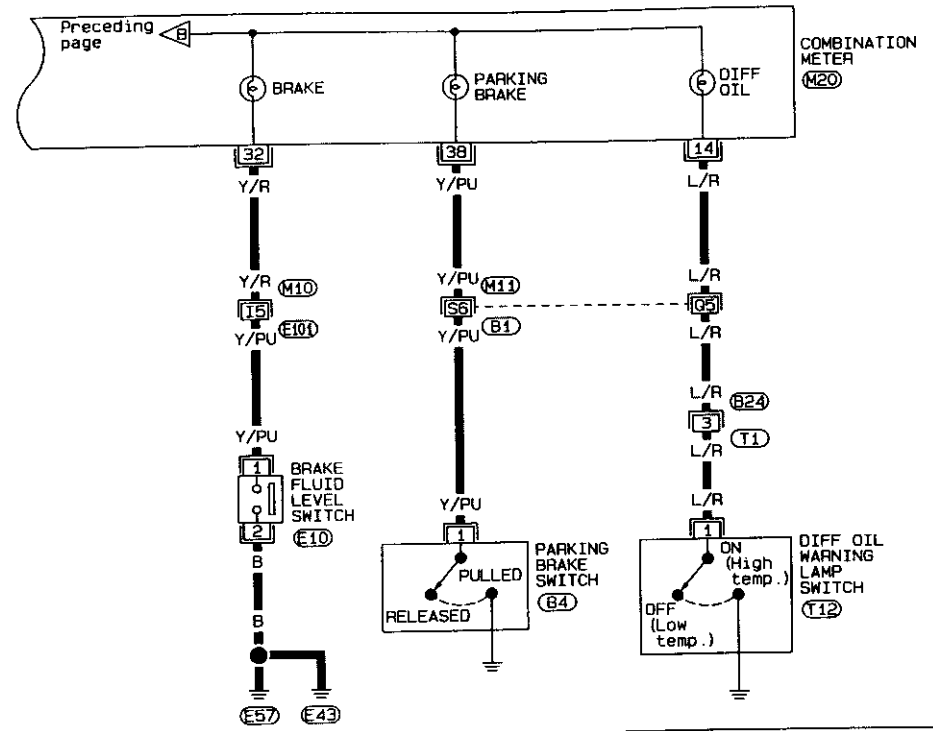

Refer to last page  
(Foldout page).

- M10, E10
- M11, B1

QI  
NA  
EM  
LC  
EC  
FE  
CL  
MT  
AT  
PD  
FA  
RA  
RR  
ST  
RS  
BT  
MA  
EL  
FBX



TESTER

**Sensor Check**

Check for the bulb to light.

81  
82  
83  
84  
85  
86  
87  
88  
89  
90  
91  
92

**Oil Pressure Check**

Oil pressure (bar, kg/cm <sup>2</sup> , psi)	Continuity
More than 10 - 20 0.20, 0.1 - 0.2, 1 - 3)	NO
Less than 10 - 20 0.20, 0.1 - 0.2, 1 - 3)	YES

93  
94  
95  
96  
97  
98  
99  
100

Check between the terminals of oil pressure

Use an ohmmeter.  
Verify properly if test results are as shown

Results may vary depending on the type of tester.  
During this inspection, be sure to refer to the manual for the tester to be used.

These lamps are built into the combination

101  
102  
103  
104  
105  
106  
107  
108  
109  
110

EL

Warning Buzzer/System Description

The warning buzzer is controlled by the smart entrance control unit.

Power is supplied at all times

- through 10A fuse (No. 21), located in the fuse block
- to warning buzzer terminal ③
- to key switch terminal ①.

Power is supplied at all times

(LHD models without daytime light system)

- through 45A fusible link (letter I), located in the fusible link and fuse box.
- to lighting switch terminal ⑪.

(LHD models with daytime light system and RHD models)

- through 10A fuse (No. 22), located in the fuse block
- to lighting switch terminal ⑪ (For Europe) or ⑫ (Except for Europe)

Power is supplied at all times

- through 25A fusible link (letter L), located in the fusible link and fuse box
- to circuit breaker terminal ①

- through circuit breaker terminal ②
- to smart entrance control unit terminal ①.

With the ignition switch in the ON or START position, power is supplied

- through 7.5A fuse (No. 26), located in the fuse block
- to smart entrance control unit terminal ①.

Ground is supplied to smart entrance control unit terminal ⑩ through body ground (M1).

When a signal, or combination of signals, is received by the smart entrance control unit, ground is supplied

- through smart entrance control unit terminal ②③
- to warning buzzer terminal ①.

With power and ground supplied, the warning buzzer will sound.

Ignition key warning buzzer (Except for Europe models)

With the key in the ignition switch in the OFF position, and the driver's door open, the warning buzzer will sound. A battery positive voltage is supplied

- from key switch terminal ②
- to smart entrance control unit terminal ②④.

Ground is supplied

- from driver side door switch terminal ①
- to smart entrance control unit terminal ①⑤.

Driver side door switch terminal ③ is grounded through body grounds (B2) and (B18).

Light warning buzzer

With ignition switch OFF, driver's door open, and lighting switch in 1ST or 2ND position, warning buzzer will sound. A battery positive voltage is supplied

(LHD models without daytime light system)

- from lighting switch terminal ⑫
- through 10A fuse (No. 14), located in the fuse block
- to smart entrance control unit terminal ②⑤.

(LHD models with daytime light system)

- from lighting switch terminal ⑫
- to daytime light unit terminal ①①
- through daytime light unit terminal ⑩⑩
- to smart entrance control unit terminal ②⑤.

- to smart entrance control unit terminal ②⑤.

(RHD models)

- from lighting switch terminal ⑫ (For Europe) or ①① (Except for Europe)
- to smart entrance control unit terminal ②⑤.

Ground is supplied

- from driver side door switch terminal ①
- to smart entrance control unit terminal ①⑤.

Driver side door switch terminal ③ is grounded through body grounds (B2) and (B18).

Warning Buzzer/Wiring Diagram — CHIME —

EL-CHIME-01

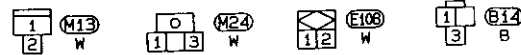
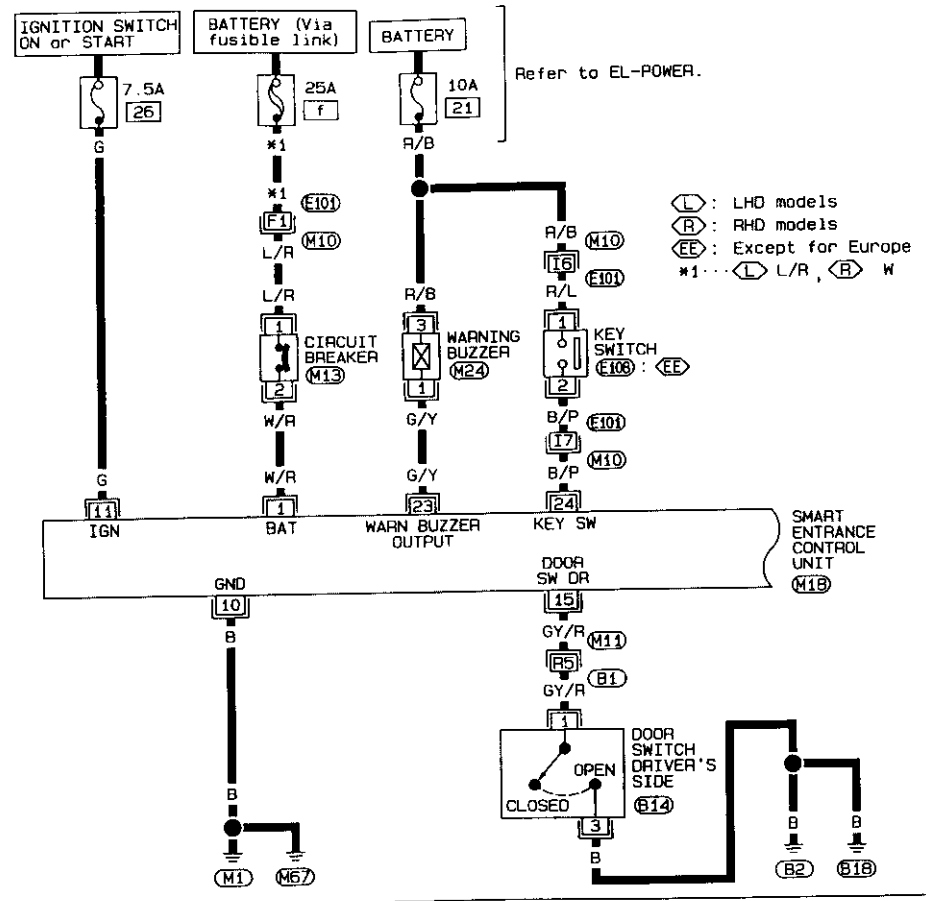

Refer to last page (Foldout page).

- (M10), (E101)
- (M11), (B1)
- (M18)

EL





## WARNING LAMPS AND BUZZER

### Trouble Diagnoses — Warning Buzzer (Cont'd) MAIN POWER SUPPLY AND GROUND CHECK

#### Main power supply

Terminals	Battery voltage existence condition		
	Ignition switch position		
	OFF	ACC	ON
① - ⑩	No	No	Yes
① - ⑩	Yes	Yes	Yes

#### Ground circuit

Terminals	Continuity
⑩ - Ground	Yes

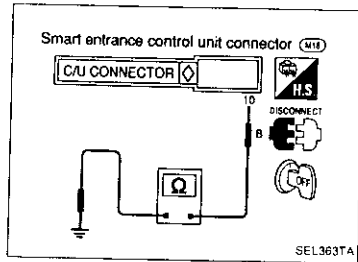
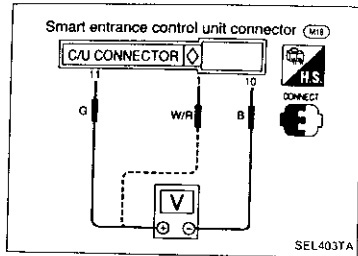

## WARNING LAMPS AND BUZZER

### Trouble Diagnoses — Warning Buzzer (Cont'd) DIAGNOSTIC PROCEDURE 1

**SYMPTOM:** Light warning buzzer does not activate.

- Perform "Preliminary check 1" before referring to the following flow chart.

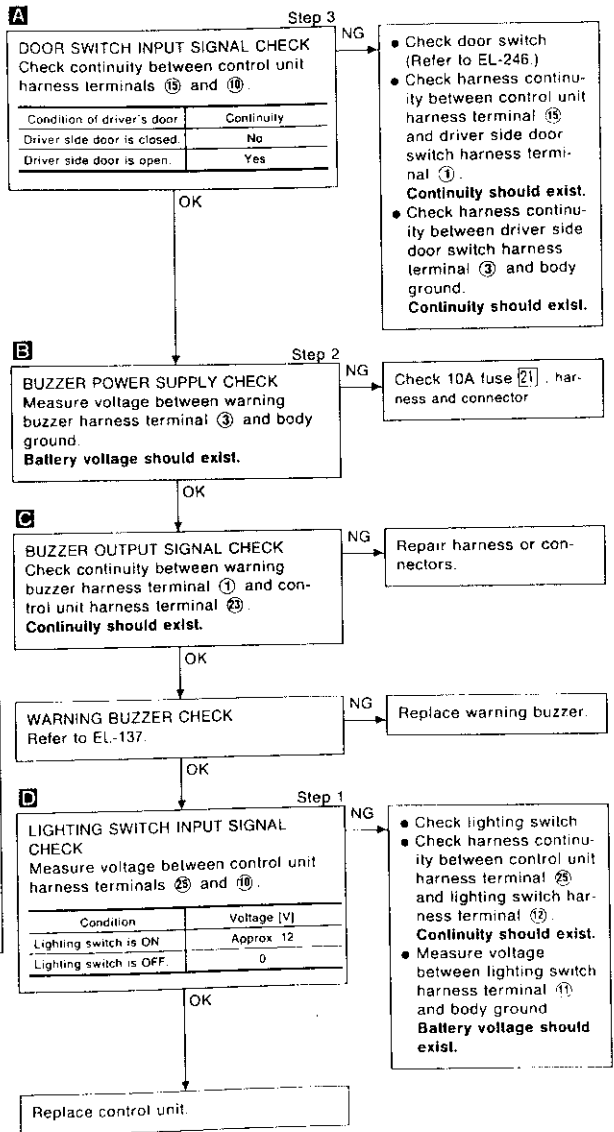
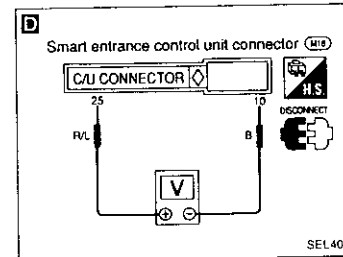
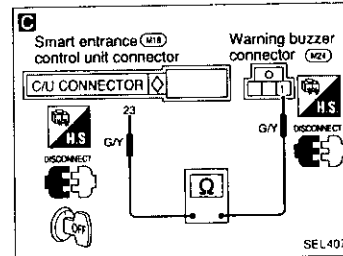
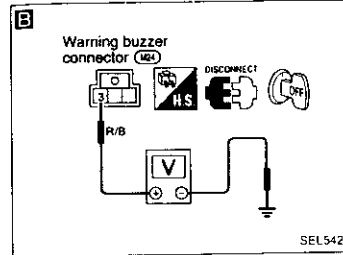
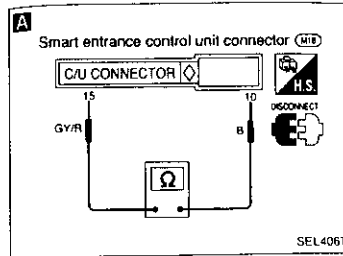

Trouble Diagnoses — Warning Buzzer (Cont'd)  
DIAGNOSTIC PROCEDURE 2

**SYMPTOM:** Ignition key warning buzzer does not activate.  
(Except Europe model)

- Perform "Preliminary check 2" before referring to the following flow chart.

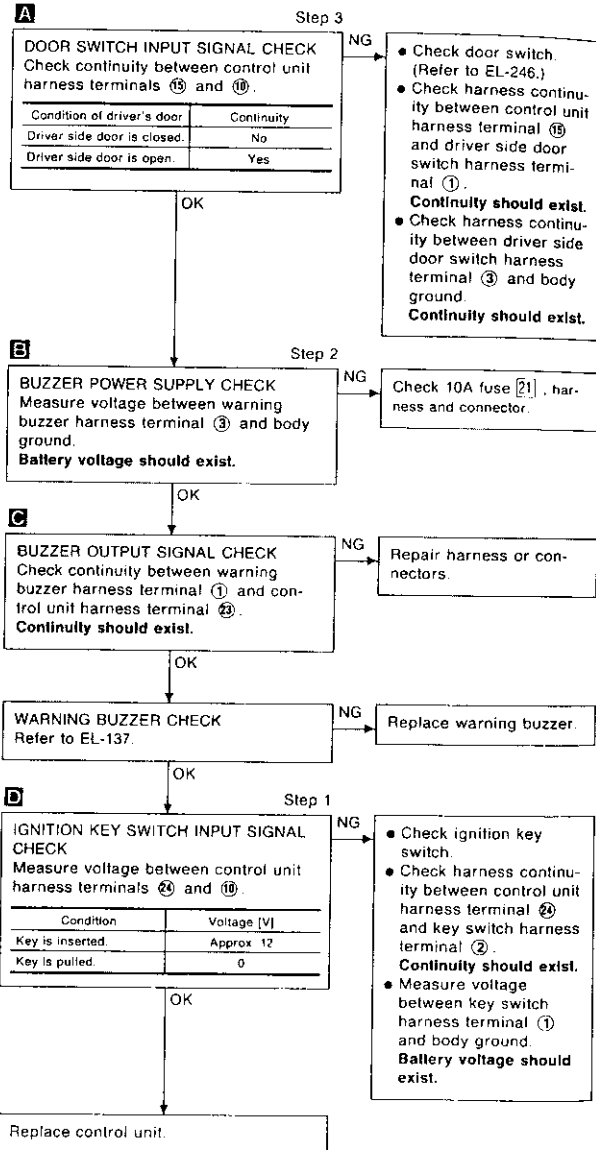
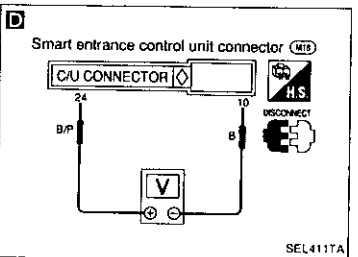
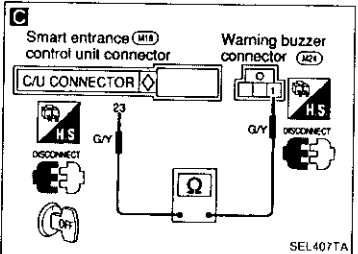
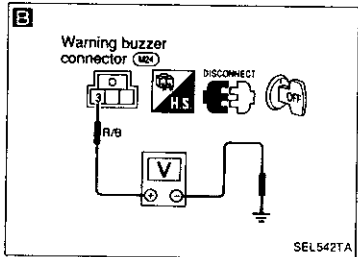
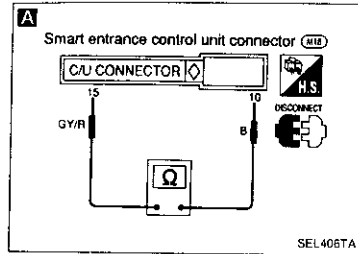

Warning Buzzer Check

Supply battery voltage to warning buzzer as shown in the illustration.

Warning buzzer should operate.

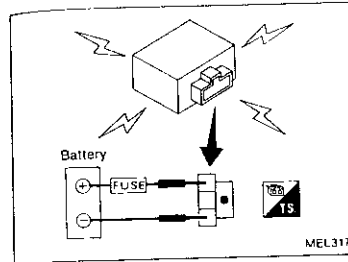

## WIPER AND WASHER

### Front Wiper and Washer/System Description (Cont'd)

#### WASHER OPERATION

When the ignition switch is in the ACC or ON position, power is supplied through 20A fuse (No. 11), located in the fuse block to washer motor terminal ①. When the lever is pulled to the WASH position, ground is supplied to washer motor terminal ②, and to wiper amplifier terminal ⑥ from terminal ⑩ of the wiper switch through terminal ⑦ of the wiper switch, and through body ground (E4) or (E7).

When power and ground are supplied, the washer motor operates.

The wiper motor operates when the lever is pulled to the WASH position for one second or more and approximately 3 seconds after the lever is released. This feature is controlled by the wiper amplifier in the same manner as the intermittent operation.

91  
92  
93  
94  
95  
96  
97  
98  
99  
100  
101  
102  
103  
104  
105  
106  
107  
108  
109  
110  
111  
112  
113  
114  
115  
116  
117  
118  
119  
120  
121  
122  
123  
124  
125  
126  
127  
128  
129  
130  
131  
132  
133  
134  
135  
136  
137  
138  
139  
140  
141  
142  
143  
144  
145  
146  
147  
148  
149  
150  
151  
152  
153  
154  
155  
156  
157  
158  
159  
160  
161  
162  
163  
164  
165  
166  
167  
168  
169  
170  
171  
172  
173  
174  
175  
176  
177  
178  
179  
180  
181  
182  
183  
184  
185  
186  
187  
188  
189  
190  
191  
192  
193  
194  
195  
196  
197  
198  
199  
200

EL

# WIPER AND WASHER

## Front Wiper and Washer/Wiring Diagram — WIPER — (Cont'd)

EL-WIPER-02

EU : For Europe  
EE : Except for Europe

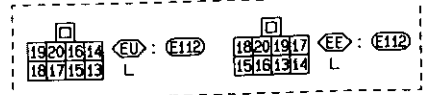
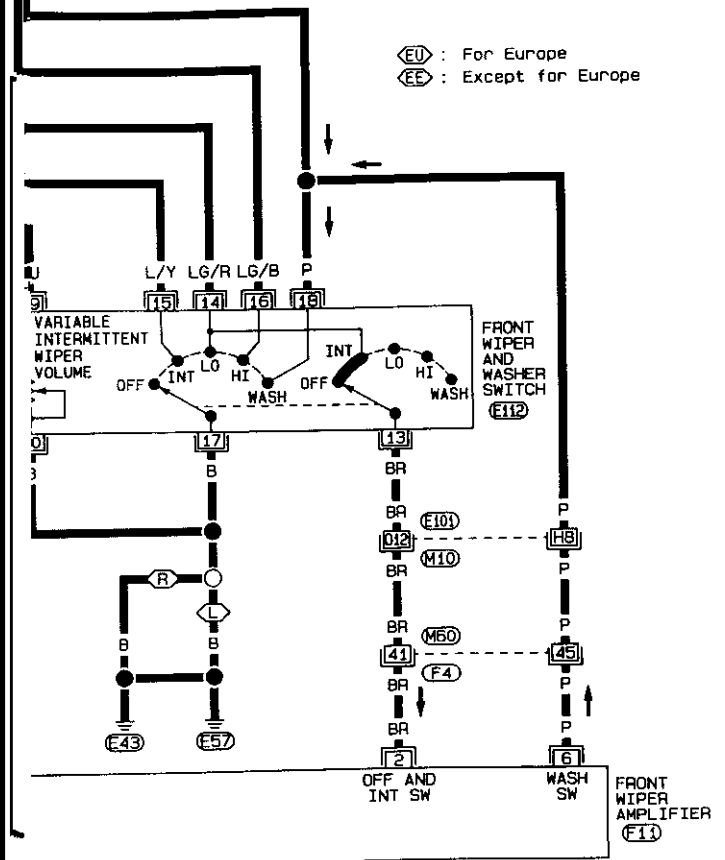

Refer to last page (Foldout page).

M10, E101  
M60, F4

GI  
MA  
EM  
LC  
EC  
FE  
CL  
MT  
AT  
PD  
FA  
RA  
BR  
ST  
RS  
BT  
HA  
EL  
DX

## WIPER AND WASHER

### Trouble Diagnoses (Cont'd)

#### DIAGNOSTIC PROCEDURE 2

SYMPTOM: Intermittent time of wiper cannot be adjusted.

**A**

**INTERMITTENT WIPER VOLUME INPUT SIGNAL CHECK**  
Measure resistance between wiper amp. harness terminals ⑥ and ③ while turning intermittent wiper volume.

Position of wiper knob	Resistance [Ω]
S	0
L	Approx. 1 k

OK

Replace wiper amp.

NG

Check intermittent wiper volume. Check harness continuity between wiper amp. harness terminal ⑥ and wiper switch harness terminal ⑩. Check harness continuity between wiper switch harness terminal ⑩ and body ground.

#### DIAGNOSTIC PROCEDURE 3

SYMPTOM: Wiper and washer activate individually but not in combination.

**A**

**WASHER SWITCH INPUT SIGNAL CHECK**  
1) Turn ignition switch to "ACC".  
2) Measure voltage between wiper amp. harness terminals ⑥ and ③.

Condition of washer switch	Voltage [V]
OFF	Approx. 12
ON	0

NG

Check harness continuity between wiper amp. harness terminal ⑥ and wiper switch harness terminal ⑩.

OK

**B**

**WIPER AMP. OUTPUT SIGNAL CHECK**  
Measure voltage between wiper amp. harness terminals ② and ③ after operating washer switch.  
0V for approx. 3 seconds after washer has operated.

NG

Check wiper switch.

OK

Replace wiper amp.



SEL823T



SEL825T

GI  
MA  
EM  
LC  
EC  
FE  
CI  
MT  
AT  
PD  
FA  
RA  
BR  
ST  
RS  
BT  
HA  
EL  
FDX

## WIPER AND WASHER

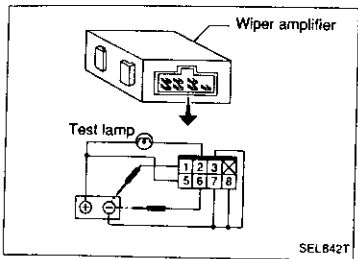

### Front Wiper Amplifier Check

1. Connect as shown in the figure at left.
2. If test lamp comes on when connected to terminal ① or ⑥ and battery ground, wiper amplifier is normal.

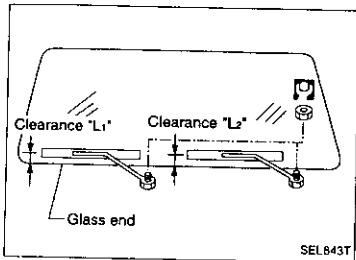

### Front Wiper Installation and Adjustment

1. Prior to wiper arm installation, turn on wiper switch to operate wiper motor and then turn it "OFF" (Auto Stop).
2. Lift the blade up and then set it down onto glass surface to set the blade center to clearance "L<sub>1</sub>" & "L<sub>2</sub>" immediately before tightening nut.
3. Eject washer fluid. Turn on wiper switch to operate wiper motor and then turn it "OFF".
4. Ensure that wiper blades stop within clearance "L<sub>1</sub>" & "L<sub>2</sub>".

Clearance "L<sub>1</sub>": 18 - 33 mm (0.71 - 1.30 in)

Clearance "L<sub>2</sub>": 17 - 32 mm (0.67 - 1.26 in)

- Tighten wiper arm nuts to specified torque.

Front wiper:

16.7 - 22.6 N·m (1.70 - 2.31 kg·m, 12.32 - 16.67 ft·lb)

- Before reinstalling wiper arm, clean up the pivot area as illustrated. This will reduce possibility of wiper arm looseness.

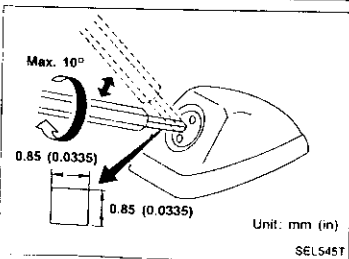
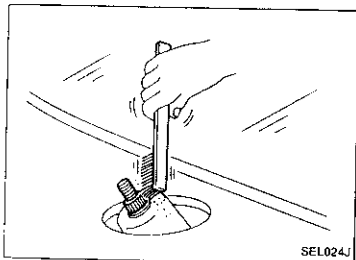

### Front Washer Nozzle Adjustment

- Using a suitable tool, adjust windshield washer nozzle to correct its spray pattern.

Adjustable range: ± 10° (in any direction)

Before attempting to turn the nozzle, gently tap the end of the tool to free the nozzle.

This will prevent "rounding out" the small female square in the center of the nozzle.

## WIPER AND WASHER

### Front Washer Nozzle Adjustment (Cont'd)

Unit: mm (in)

*1	358 (14.09)	*5	70 (2.76)
*2	245 (9.65)	*6	245 (9.65)
*3	300 (11.81)	*7	378 (14.88)
*4	203 (7.99)	*8	503 (19.80)

\*: The diameters of these circles are less than 80 mm (3.15 in).

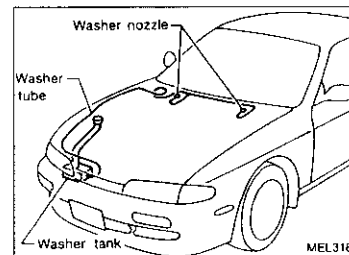
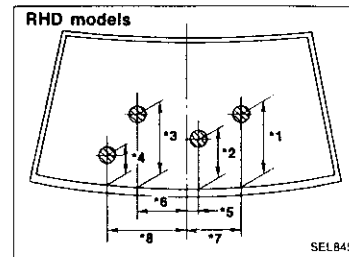
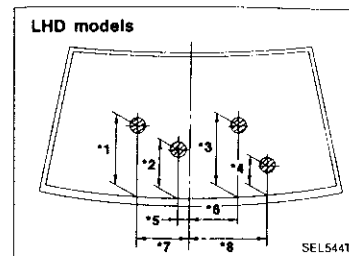

### Front Washer Tube Layout

## WIPER AND WASHER

### Front Wiper Linkage

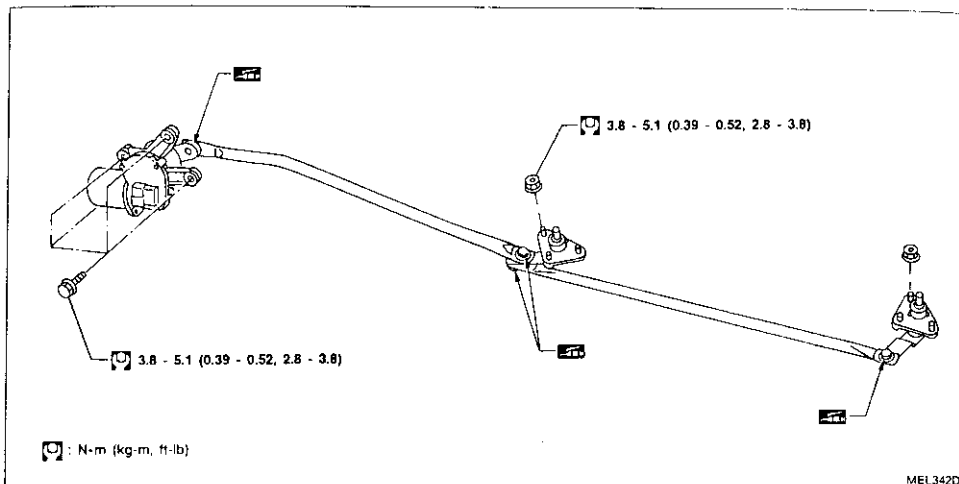

This illustration is for LHD models. For RHD models, these units are installed on the opposite side.

#### REMOVAL

1. Remove 4 bolts that secure wiper motor.
2. Detach wiper motor from wiper linkage at ball joint.
3. Remove wiper linkage.

**Be careful not to break ball joint rubber boot.**

#### INSTALLATION

- Grease ball joint portion before installation.
1. Installation is the reverse order of removal.

## WIPER AND WASHER

### Rear Wiper and Washer/System Description

#### WIPER OPERATION

The rear wiper switch is controlled by a ring built into the combination switch. There are two wiper switch positions:

- ON (LO speed)
- INT (Intermittent)

With the ignition switch in the ACC or ON position, power is supplied

- through 10A (LHD models) or 15A (RHD models) fuse (No. 16) (LHD models) or 14) (RHD models), located in the fuse block
- to rear wiper motor terminal ④, and
- to rear wiper relay terminal ①.

#### Low speed wiper operation

Ground is supplied to rear wiper switch terminal ② through body ground (E43) or (E57). When the rear wiper is placed in the ON position, ground is supplied

- through rear wiper switch terminal ②
- to rear wiper relay terminal ②.

The rear wiper relay is energized and ground is supplied

- to rear wiper motor terminal ①
- through rear wiper relay terminal ③
- to rear wiper relay terminal ⑤
- through body ground (T19).

#### Auto stop operation

With the rear wiper switch turned OFF, rear wiper motor will continue to operate until wiper arm reaches rear window base.

When wiper arm is not located at base of rear window with rear wiper switch OFF, rear wiper relay is not energized and ground is supplied

- to rear wiper motor terminal ①
- through rear wiper relay terminal ③
- to rear wiper relay terminal ④
- through rear wiper motor terminal ③, in order to continue rear wiper motor operation at low speed.

Ground is also supplied

- to rear wiper motor terminal ②
- through body ground (B2) or (B19).

When wiper arm reaches base of rear window, rear wiper motor terminals ① and ④ are connected instead of terminals ① and ③. Rear wiper motor will then stop wiper arm at the PARK position.

#### Intermittent operation

The rear wiper motor operates the wiper arm one time at low speed at an interval of approximately 7 seconds. This feature is controlled by rear wiper amplifier.

With the ignition switch in the ACC or ON position, power is supplied

- through 10A (LHD models) or 15A (RHD models) fuse (No. 16) (LHD models) or 14) (RHD models), located in the fuse block
- to rear wiper relay terminal ①.

When the rear wiper switch is placed in the INT position, ground is supplied

- to rear wiper amplifier terminal ②
- from rear wiper switch terminal ②
- through body ground (E43) or (E57).

Ground is also supplied

- to rear wiper relay terminal ②
- through rear wiper amplifier terminal ⑥
- to rear wiper amplifier terminal ⑤
- through body ground (M1).

Then the rear wiper relay is energized and ground is supplied

- to rear wiper motor terminal ①
- through rear wiper relay terminal ③
- to rear wiper relay terminal ⑤
- through body ground (T19).



## WIPER AND WASHER

### Rear Wiper and Washer/System Description (Cont'd)

With power and ground supplied, the rear wiper motor operates intermittently.

#### WASHER OPERATION

With the ignition switch in the ACC or ON position, power is supplied

- through 10A (LHD models) or 15A (RHD models) fuse (No. 16 (LHD models) or 14 (RHD models), located in the fuse block)

- to rear washer motor terminal ①.

When the ring is turned WASH position, ground is supplied

- to rear washer motor terminal ②, and
- to rear wiper amplifier terminal ①
- from terminal ③ of rear wiper switch
- through terminal ④ of rear wiper switch, and
- through body ground (E43) or (E57).

With power and ground is supplied, the rear washer motor operates.

The rear wiper motor operates when the ring is turned to WASH position for one second or more and for approximately 3 seconds after the ring is released. This feature is controlled by the rear wiper amplifier in the same manner as the intermittent operation.

## WIPER AND WASHER

### Rear Wiper and Washer/Wiring Diagram — WIP/R —

EL-WIP/R-01

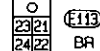
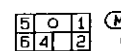
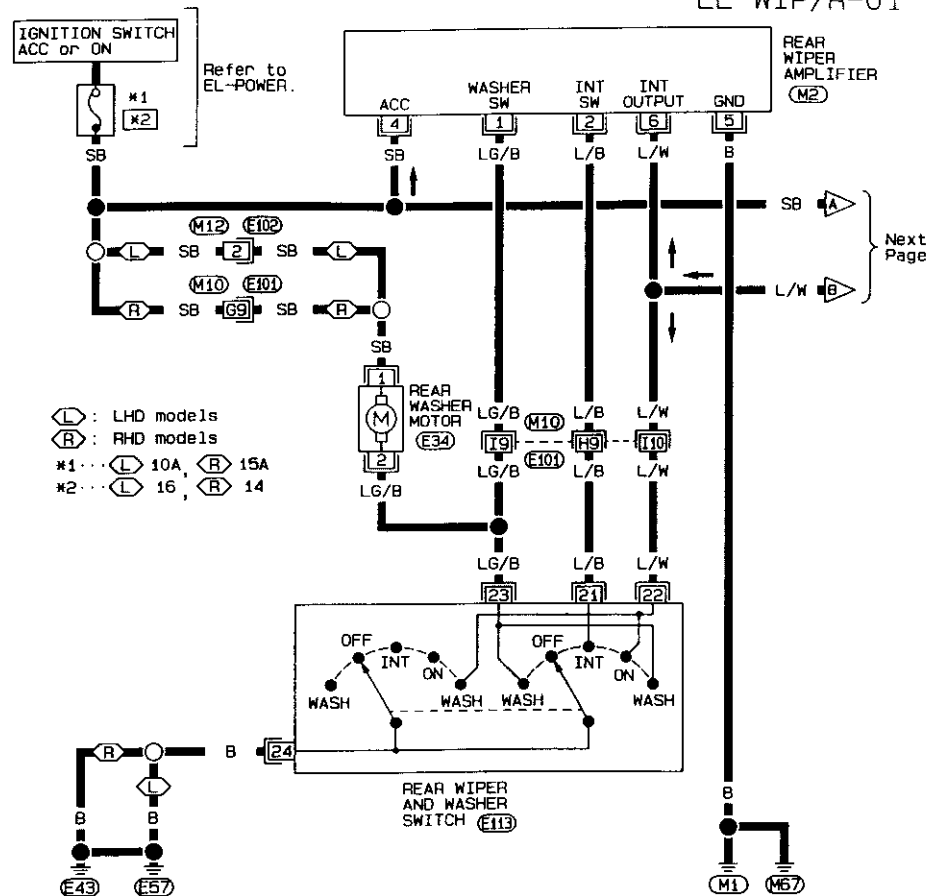

Refer to last page  
(Foldout page).

M10, E101

## WIPER AND WASHER

### Rear Wiper and Washer/Wiring Diagram — WIP/R — (Cont'd)

EL-WIP/R-02

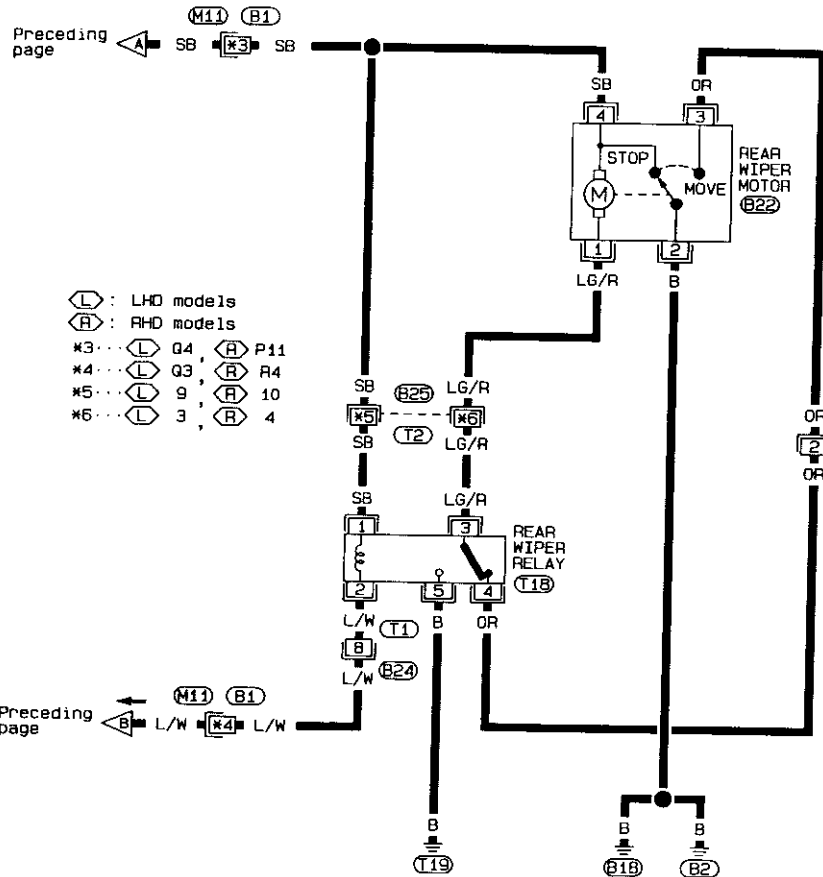

- L : LHD models
- R : RHD models
- \*3 : L Q4, R P11
- \*4 : L Q3, R R4
- \*5 : L 9, R 10
- \*6 : L 3, R 4

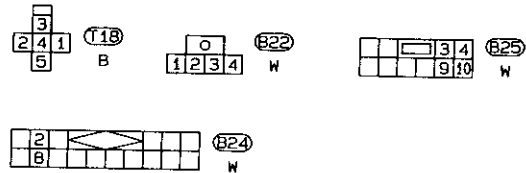

Refer to last page  
(Foldout page).

M11 (B1)

SEL744T

EL-150

## WIPER AND WASHER

### Rear Wiper Amplifier Check

1. Connect as shown in the figure at left.
2. If test lamp comes on when connected to terminal ① or ② and battery ground, wiper amplifier is normal.

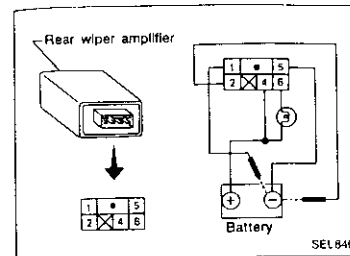

### Rear Wiper Installation and Adjustment

1. Prior to wiper arm installation, turn on wiper switch to operate wiper motor and then turn it "OFF" (Auto Stop).
2. Lift the blade up and then set it down onto glass surface to set the blade center to clearance "L<sub>3</sub>" immediately before tightening nut.
3. Eject washer fluid. Turn on wiper switch to operate wiper motor and then turn it "OFF".
4. Ensure that wiper blades stop within clearance "L<sub>3</sub>".

Clearance "L<sub>3</sub>": 26 - 42 mm (1.02 - 1.65 in)

- Tighten wiper arm nuts to specified torque.

Rear wiper:

12.7 - 17.7 N·m (1.30 - 1.81 kg·m, 9.37 - 13.06 ft·lb)

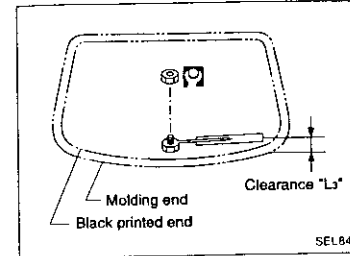

- Before reinstalling wiper arm, clean up the pivot area as illustrated. This will reduce possibility of wiper arm looseness.

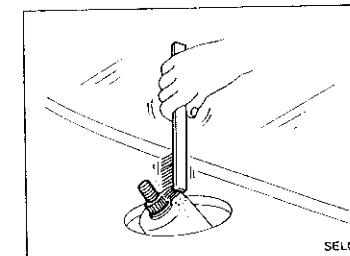

### Rear Washer Nozzle Adjustment

- Using a suitable tool, adjust rear window washer nozzle to correct its spray pattern.  
Adjustable range: ±15° (in any direction)

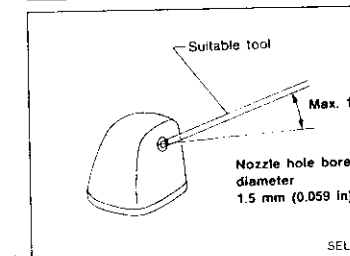

EL-151

EL

## WIPER AND WASHER

### Rear Washer Nozzle Adjustment (Cont'd)

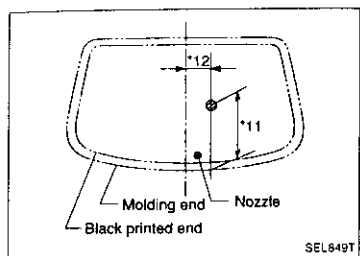

Unit: mm (in)

*11	219 (8.62)	*12	45 (1.77)
-----	------------	-----	-----------

\*: The diameters of these circles are less than 90 mm (3.54 in).

### Rear Washer Tube Layout

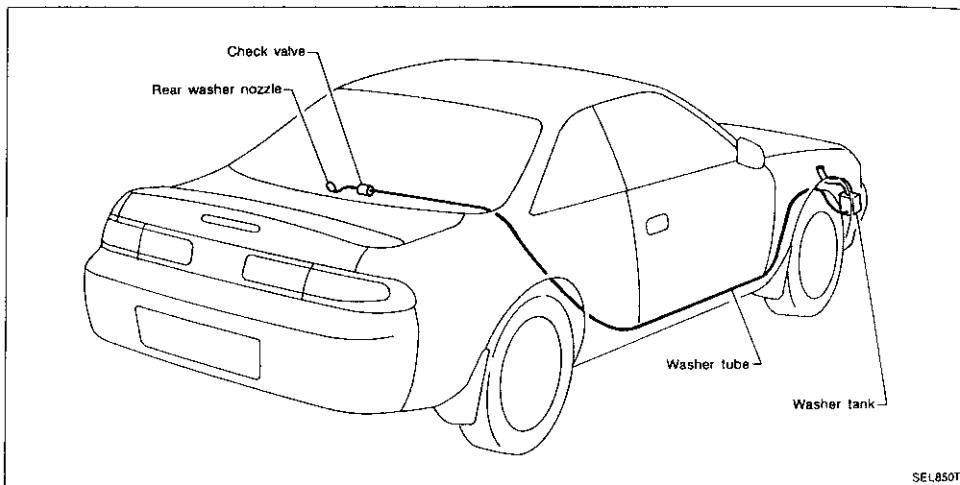

### Check Valve (For rear washer)

- A check valve is provided in the rear washer fluid line. Be careful not to connect check valve to washer tube in the wrong direction.

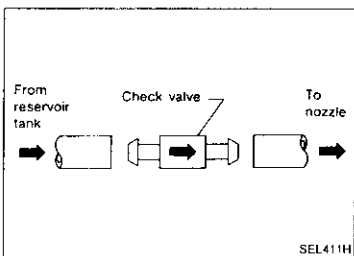

## WIPER AND WASHER

### Headlamp Washer/System Description

Power is supplied at all times

- through 25A fusible link (letter **L**), located in the fusible link and fuse box
- to headlamp washer motor terminal **①**.

Power is also supplied at all times

- through 20A fuse (No. **38**), located in the fusible link and fuse box
- to lighting switch terminal **⑧**.

### Headlamp washer operation

The headlamp washer operates for approximately 1 second at one time. This feature is controlled by headlamp washer amplifier.

For headlamp washer operation, the lighting switch must be in the 2ND position and ignition switch in the ON or START position.

With the headlamp washer switch in the ON position, ground is supplied

- to headlamp washer amplifier terminal **②**
- through headlamp washer switch terminal **①**
- to headlamp washer switch terminal **⑤**
- through body ground (**M1**) or (**M57**).

Ground is also supplied

- to headlamp washer motor terminal **②**
- through headlamp washer amplifier terminal **④**
- to headlamp washer amplifier terminal **⑤**
- through body ground (**E43**).

With power and ground supplied, headlamp washer will operate.

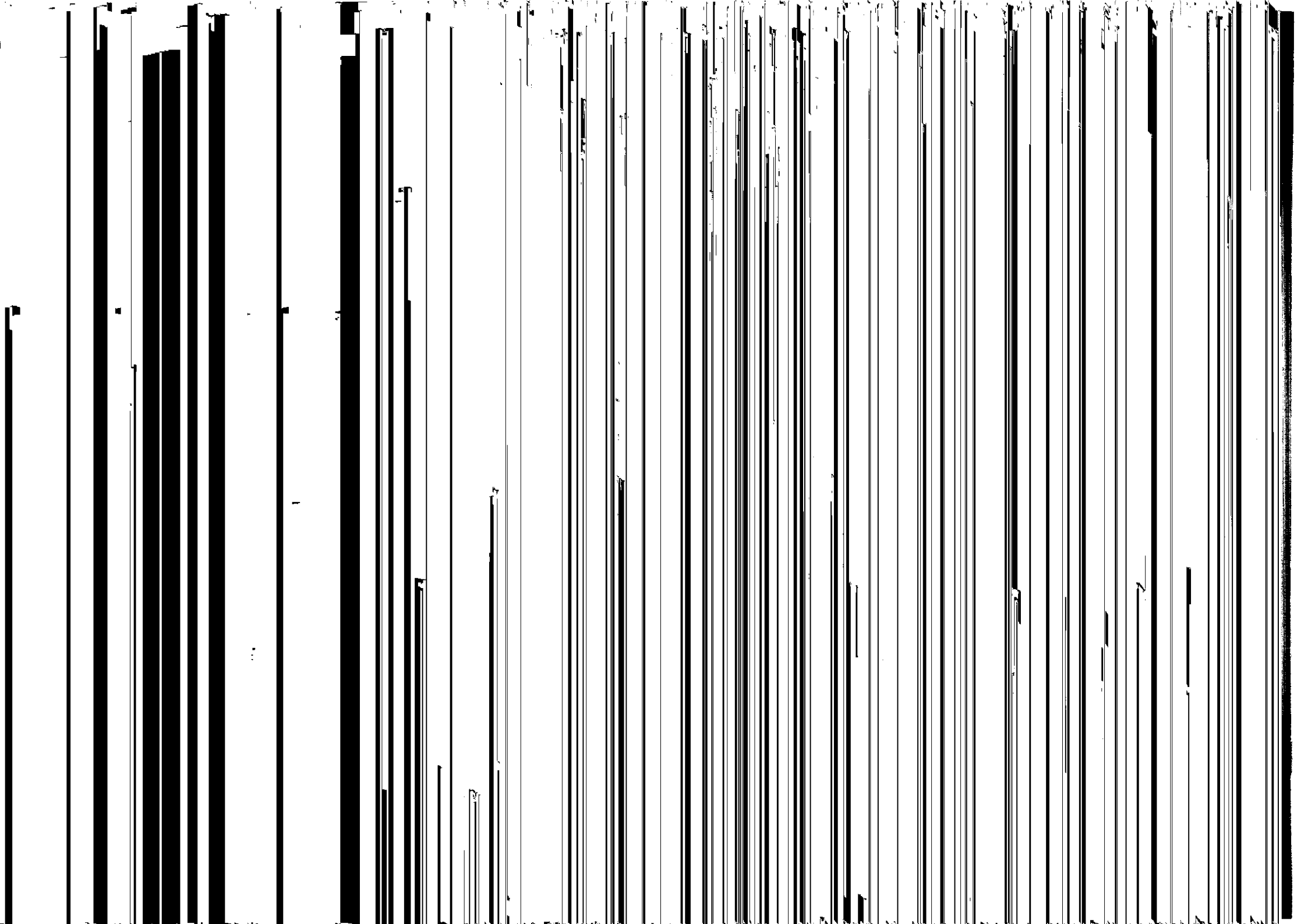

**Headlamp Washer Amplifier Check**

1. Connect as shown in the figure at left.
2. If test lamp comes on when connected to the terminal ② and battery ground, headlamp washer amplifier is normal.

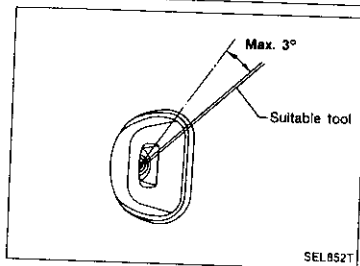
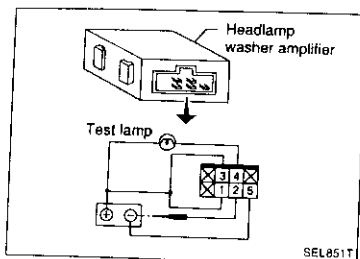

**Headlamp Washer Nozzle Adjustment**

- Using a suitable tool, adjust headlamp washer nozzle to correct its spray pattern.  
**Adjustable range: ± 3° (Up and down)**

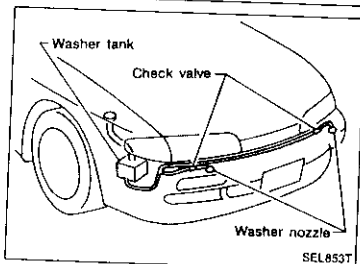

**Headlamp Washer Tube Layout**

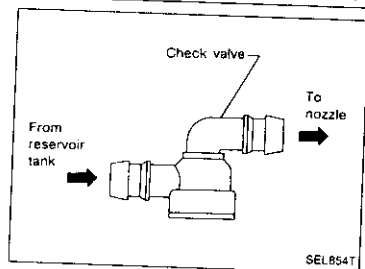

**Check Valve (For headlamp washer)**

**System Description**

Power is supplied at all times

- from 25A fusible link (Letter **T** located in the fuse and fusible link box)
- to circuit breaker terminal ①
- through circuit breaker terminal ②
- to power window relay terminal ③.

With ignition switch in ON or START position, power is supplied

- through 7.5A fuse (No. **26** located in the fuse block)
  - to power window relay terminal ①.
- Ground is supplied to power window relay terminal ②
- through body ground (**MT**).

The power window relay is energized and power is supplied

- through power window relay terminal ⑤
- to power window main switch terminal ⑤.
- to power window sub-switch terminal ④.
- to power window amplifier terminal ③ and
- to power window amplifier terminal ④.

**MANUAL OPERATION**

**Driver side door**

Ground is supplied

- to power window main switch terminal ④ and
- to power window amplifier terminal ⑦
- through body ground (**MT**).

**WINDOW UP**

When the driver side switch in the power window main switch is pressed in the up position, ground signal is supplied

- to power window amplifier terminal ①
- from power window main switch terminal ③.

Power is supplied

- to driver side power window regulator terminal ①
- through power window amplifier terminal ⑤.

Ground is supplied

- to driver side power window regulator terminal ②
- through power window amplifier terminal ⑥.

Then, the motor raises the window until the switch is released.

**WINDOW DOWN**

When the driver side switch in the power window main switch is pressed in the down position, ground signal is supplied

- to power window amplifier terminal ②
- from power window main switch terminal ②.

Power is supplied

- to driver side power window regulator terminal ②
- through power window amplifier terminal ⑥.

Ground is supplied

- to driver side power window regulator terminal ①
- through power window amplifier terminal ⑤.

Then, the motor lowers the window until the switch is released.

**Passenger side door**

Ground is supplied

- to power window main switch terminal ④
- through body ground (**MT**).

GI  
MA  
EM  
LC  
EC  
FE  
CL  
MT  
AT  
PD  
FA  
RA  
BR  
ST  
RS  
BT  
HA  
EL  
DX

## POWER WINDOW System Description (Cont'd)

### NOTE:

Numbers in parentheses are terminal numbers, when power window switch is pressed in the UP and DOWN positions respectively.

### MAIN SWITCH OPERATION

Power is supplied

- through power window main switch (⑥, ⑦)
- to power window sub-switch (①, ⑤).

The subsequent operation is the same as the sub-switch operation.

### SUB-SWITCH OPERATION

Power is supplied

- through power window sub-switch (②, ③)
- to passenger side power window regulator (①, ②).

Ground is supplied

- to passenger side power window regulator (②, ①)
- through power window sub-switch (③, ②)
- to power window sub-switch (⑤, ①)
- through power window main switch (⑦, ⑥).

Then, the motor raises or lowers the window until the switch is released.

### AUTO OPERATION

The power window AUTO feature enables the driver to raise or lower the driver's window without holding the window switch.

The AUTO feature only operates on the driver's window.

When a power window main switch is pressed and released the AUTO position, ground signal is supplied

- to power window amplifier terminal ⑧
- from power window main switch terminal ①.

The subsequent operation is the same as the manual operation of driver side door.

Then, the driver side door window will fully close or fully open.

### POWER WINDOW LOCK

The power window lock is designed to lock-out window operation to passenger side door window.

When the lock switch is pressed to lock position, ground of the passenger side switch in the power window main switch is disconnected. This prevents the power window motors from operating.

## POWER WINDOW

### Schematic

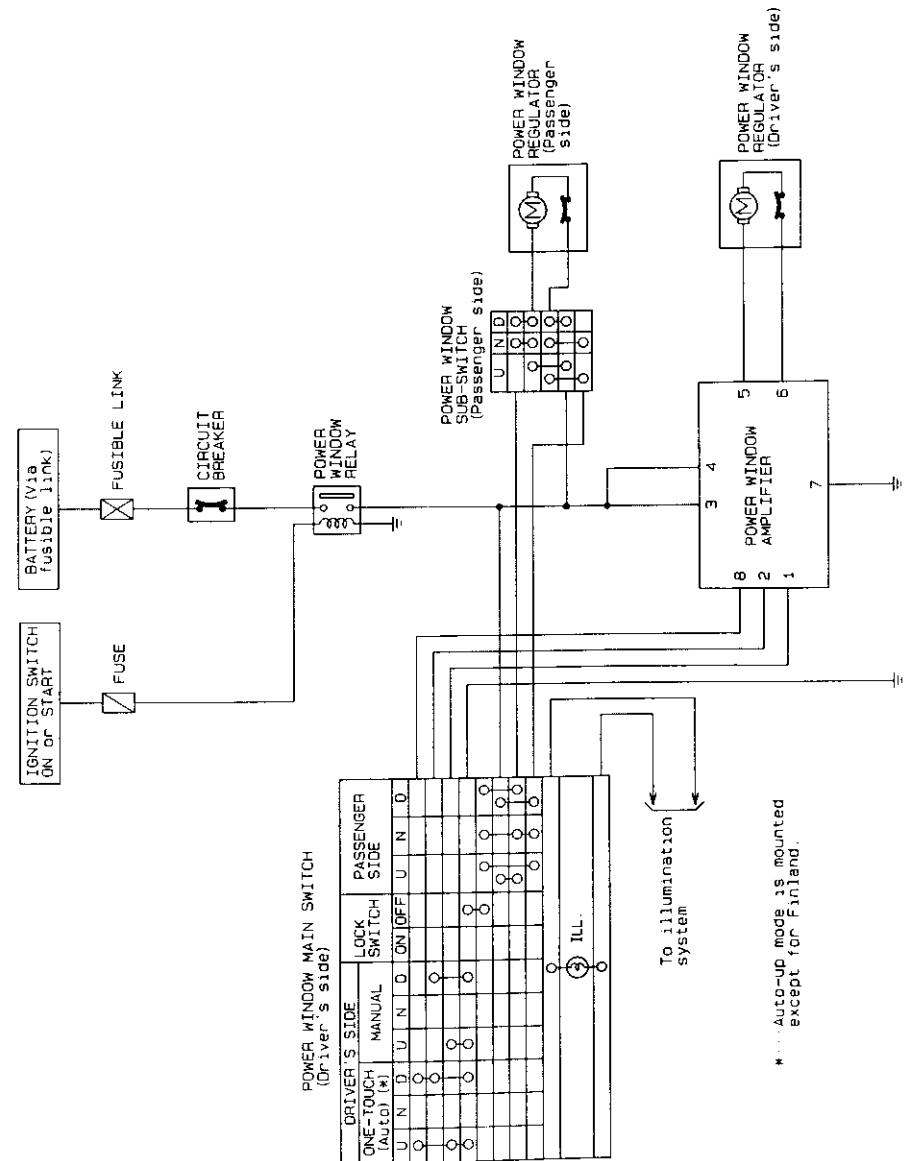

GI  
MA  
EM  
LC  
EC  
BE  
CL  
MT  
AT  
PD  
FA  
BA  
BR  
ST  
BS  
BT  
HA  
EL  
DX

POWER WINDOW

Wiring Diagram — WINDOW —

EL-WINDOW-01

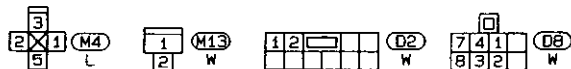
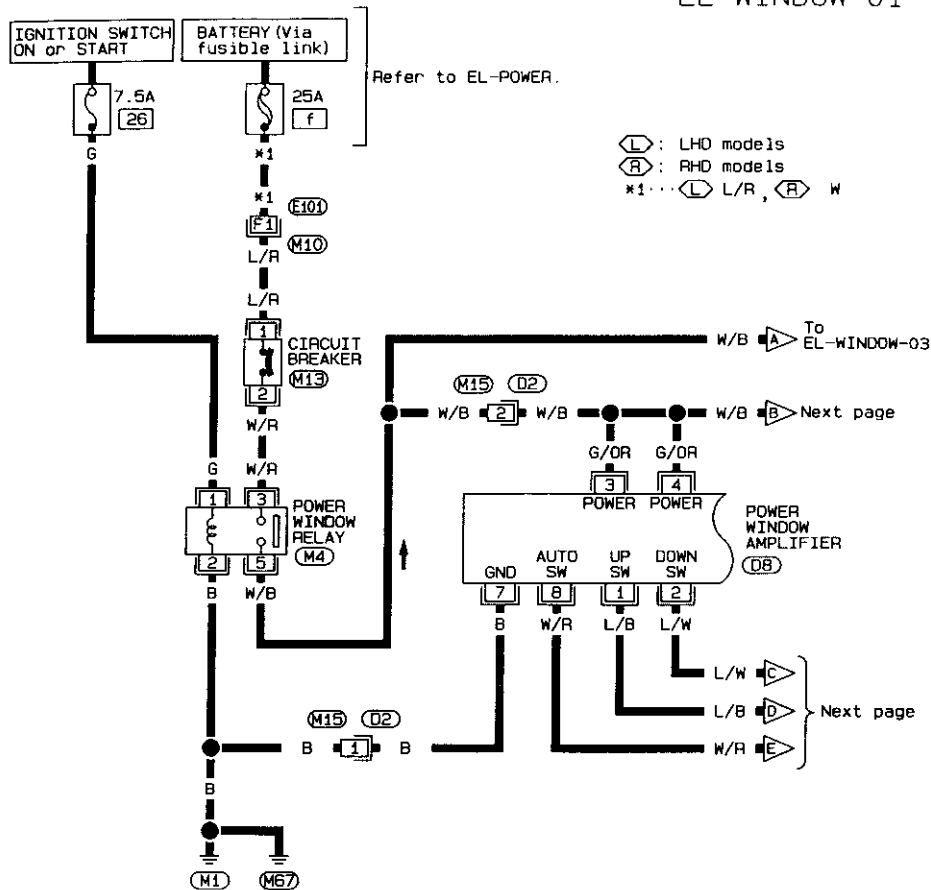

Refer to last page (Foldout page).

(M10, E10)

POWER WINDOW

Wiring Diagram — WINDOW — (Cont'd)

EL-WINDOW-02

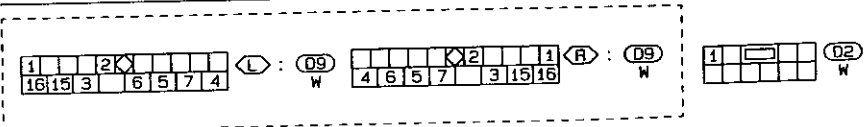
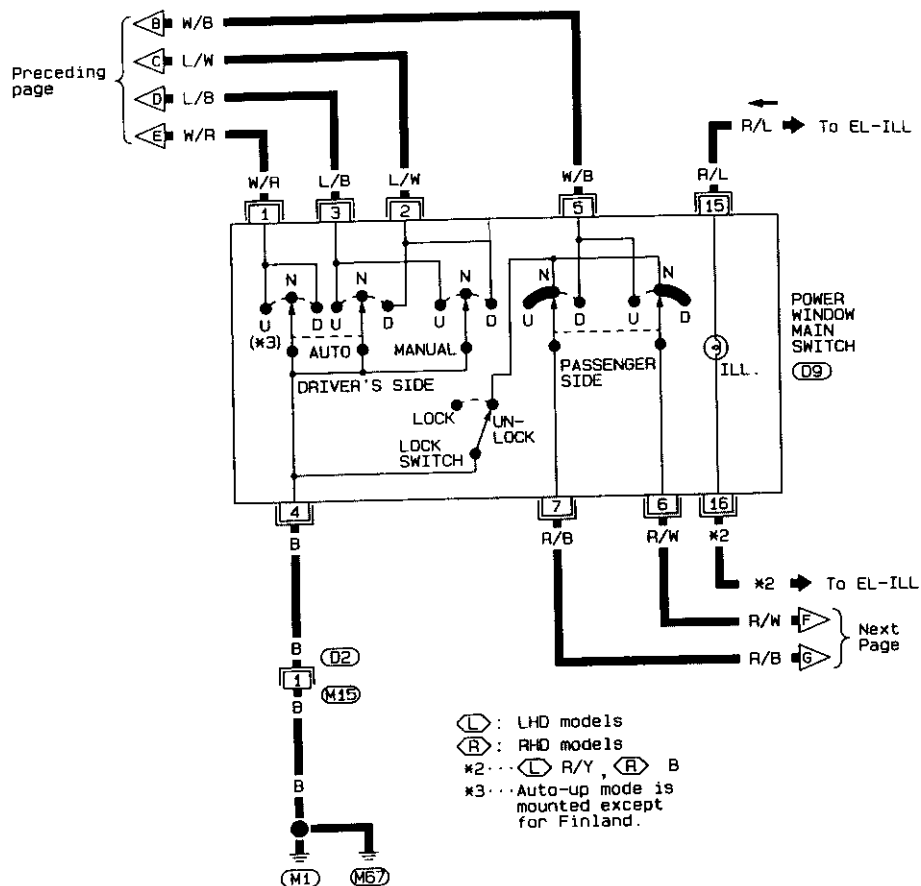

**POWER WINDOW**  
Wiring Diagram — WINDOW — (Cont'd)

EL-WINDOW-03

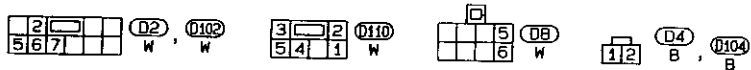
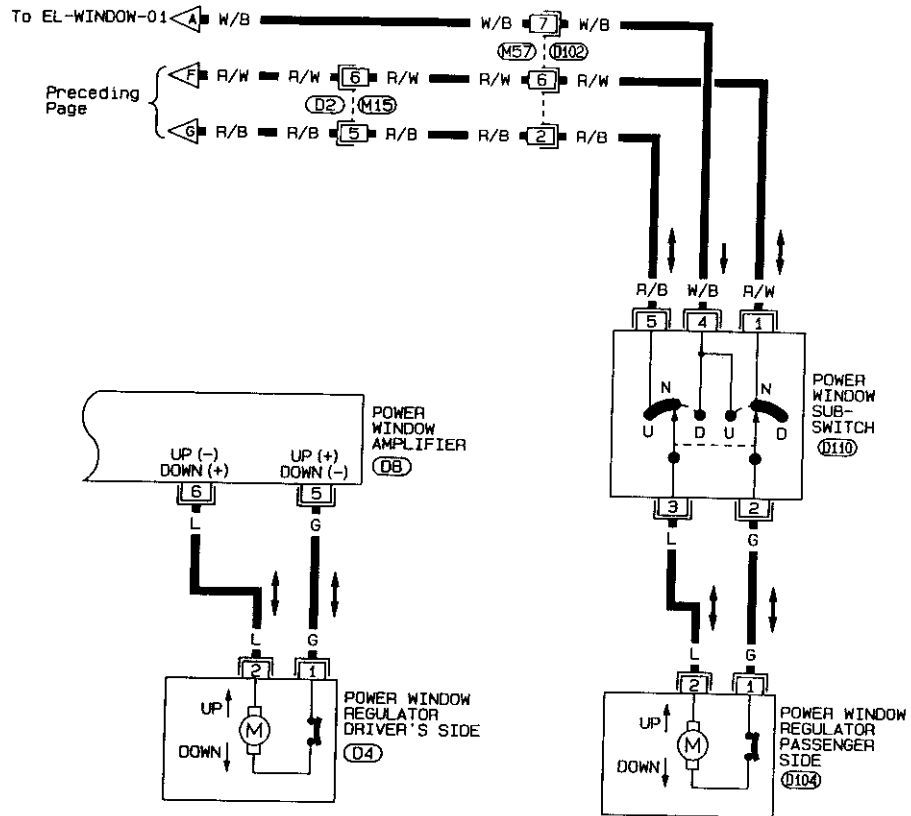

**POWER WINDOW**

**Trouble Diagnosis**

**DIAGNOSTIC PROCEDURE 1**

**SYMPTOM:** Driver and passenger power window cannot be operated.

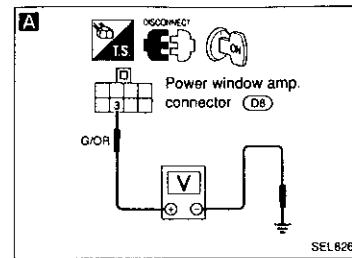

**A**  
**CHECK MAIN POWER SUPPLY AND GROUND CIRCUIT.**  
1) Disconnect power window amp. connector.  
2) Check voltage while ignition switch is "ON".

- NG → Check the following
- Fuse
  - Power window relay
  - Power supply harness

Terminals	Voltage (V)
⑦ - GND	Approx. 12

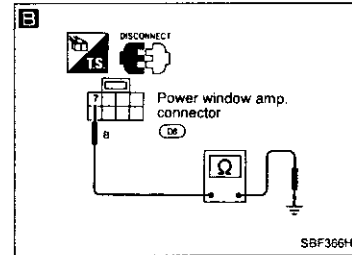

**B**  
Check continuity between power window amp. terminal ⑦ and GND.  
**Does continuity exist?**

No → Repair harness.

Yes → Go to DIAGNOSTIC PROCEDURE 2 and 3.



## POWER WINDOW

### Trouble Diagnosis (Cont'd) DIAGNOSTIC PROCEDURE 2

**SYMPTOM:** Driver's power window cannot be operated but passenger power window can be operated.

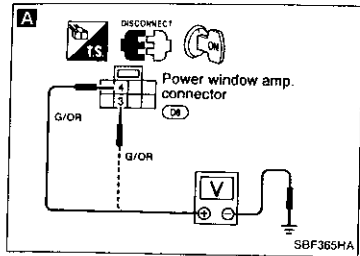

**A**

#### CHECK POWER SUPPLY FOR POWER WINDOW AMP.

- 1) Disconnect connector from power window amp.
- 2) Check voltage across power window amp. terminal ③ and GND, ④ and GND while ignition switch is "ON".

Terminals	Battery voltage existence
③ - GND	Yes
④ - GND	Yes

NG → Repair harness between power window relay and power window amp

OK

**B**

#### CHECK POWER WINDOW MAIN SWITCH CIRCUIT.

- 1) Disconnect connector from power window main switch.
- 2) Check continuity.

Power window main switch operation	Terminals
Auto (Down)	① - ④
Up	③ - ④
Down	② - ④

Does continuity exist?

Yes

No → Replace power window main switch.

**C**

- 1) Disconnect connector from power window amp. connector
- 2) Check continuity.

	Terminals
Auto	① - ⑧
Up	③ - ①
Down	② - ②

Does continuity exist?

Yes

No → Repair harness.

(Go to next page)

## POWER WINDOW

### Trouble Diagnosis (Cont'd)

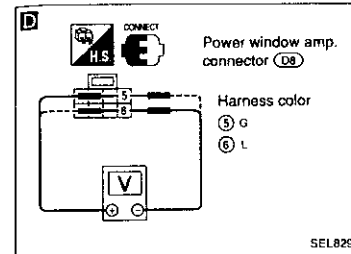

**D**

#### CHECK POWER WINDOW MOTOR CIRCUIT.

- 1) Connect power window amp. connector.
- 2) Check voltage for power window motor.

Terminals	Power window main switch operation	
④	⑤	Up
⑤	⑥	Down
⑥	⑤	

Does battery voltage exist?

Yes

No → Replace power window amp.

**E**

- 1) Disconnect driver side power window regulator connector.
- 2) Check continuity.

Terminals
⑤ - ①
⑥ - ②

Does continuity exist?

Yes

No → Repair harness.

Check driver side power window motor. Refer to "ELECTRICAL COMPONENTS INSPECTION" (EL-168).

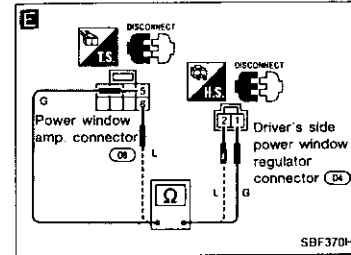

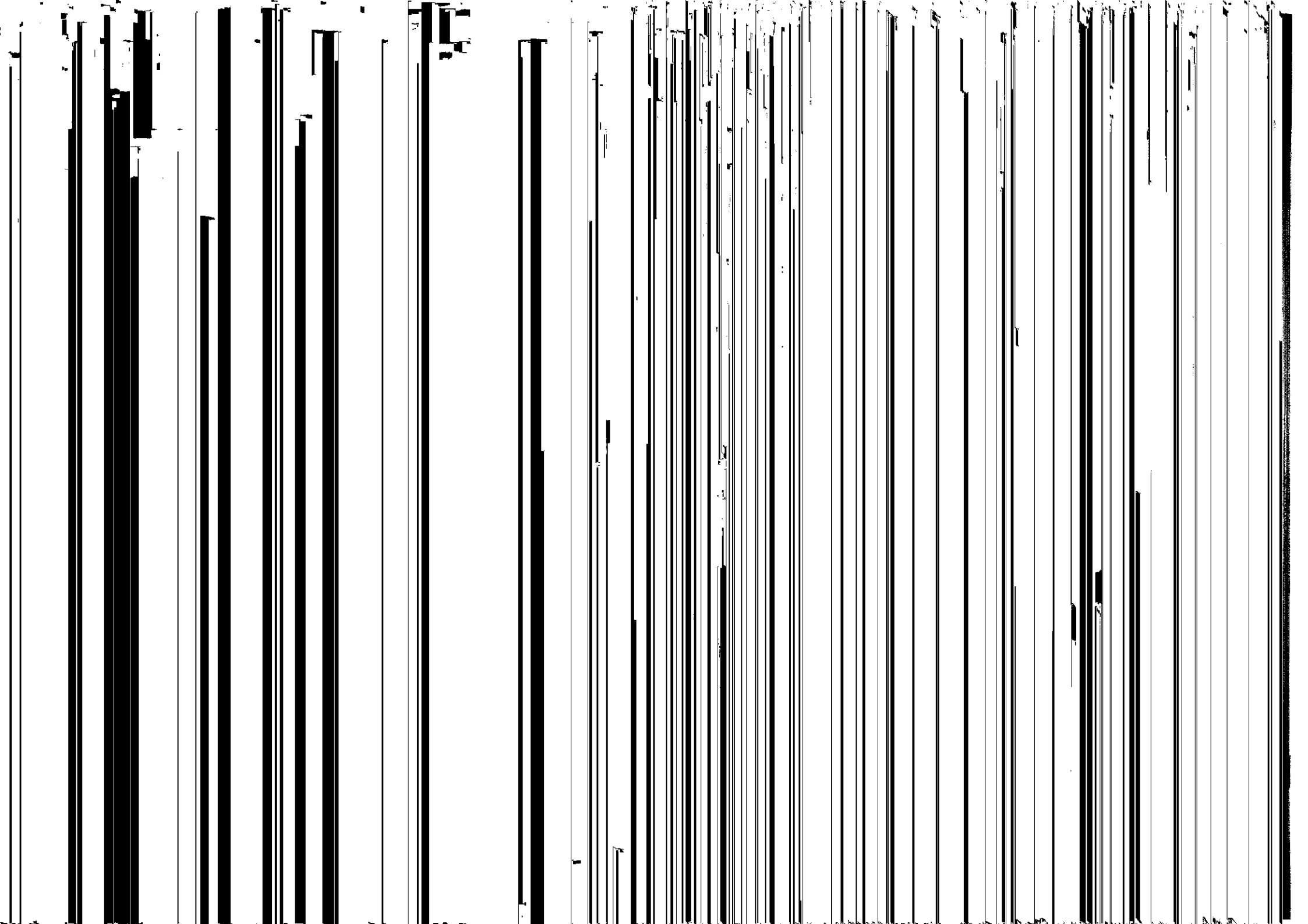

## POWER WINDOW

### Trouble Diagnosis (Cont'd)

#### DIAGNOSTIC PROCEDURE 3-3

**SYMPTOM:** Passenger power window cannot be operated using sub-switch. But driver side and passenger side (using main switch) can be operated.

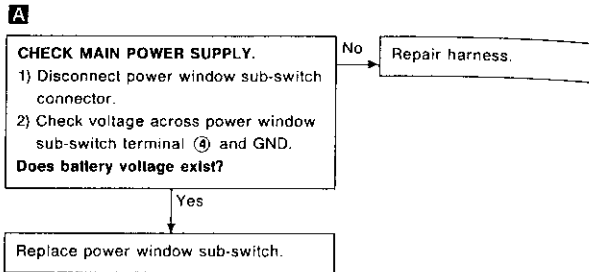
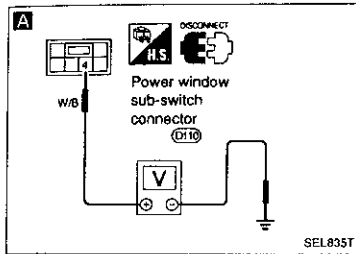

**Note:** If passenger power window does not lock using lock button of main switch, replace main switch.

## ELECTRICAL COMPONENTS INSPECTION

### POWER WINDOW MOTOR

Terminals		Operation
⊕	⊖	
①	②	Upward
②	①	Downward

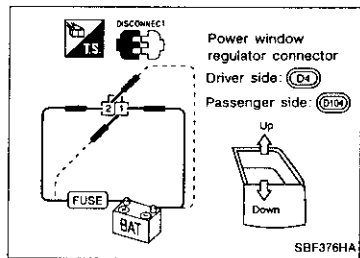

## POWER DOOR LOCK

### System Description

Power is supplied at all times

- through 25A fusible link (No. ① located in the fuse and fusible link box)
- to circuit breaker terminal ①
- through circuit breaker terminal ②
- to smart entrance control unit terminal ①.

Ground is supplied to smart entrance control unit terminal ⑩ through body ground (MT).

### POWER DOOR LOCK OPERATION

When one of the following input signals is supplied:

- driver side door is locked/unlocked using key or lock knob,
- passenger side door is locked/unlocked using key or lock knob (Only for models with multi-remote control system);

Smart entrance control unit locks/unlocks driver side door (Only for models with multi-remote control system) and passenger side door.

For operation by the remote controller, refer to "MULTI-REMOTE CONTROL SYSTEM".

#### Input (Unlock signal)

##### Models with multi-remote control system

When the driver side door is unlocked using key or lock knob, ground is supplied

- to smart entrance control unit terminal ⑫
- through driver side door lock actuator (door unlock sensor) terminal ④
- to driver side door lock actuator (door unlock sensor) terminal ②
- through body ground (MT).

When the passenger side door is unlocked using key or lock knob, ground is supplied

- to smart entrance control unit terminal ⑬
- through passenger side door lock actuator (door unlock sensor) terminal ④
- to passenger side door lock actuator (door unlock sensor) terminal ②
- through body ground (MT).

##### Models without multi-remote control system

When the driver side door is unlocked using key or lock knob, ground is supplied

- to smart entrance control unit terminal ⑫
- through lock knob switch terminal ②
- to lock knob switch terminal ①
- through body ground (MT).

#### Input (Lock signal)

The smart entrance control unit terminal ⑫ or ⑬ receives lock signal when the unlock signal is shut off.

#### Output (Unlock)

##### Driver side door (Models with multi-remote control system)

Power is supplied

- to driver side door lock actuator terminal ①
- through smart entrance control unit terminal ③.

Then, the door is unlocked.

Ground is supplied

- to driver side door lock actuator terminal ③
- through smart entrance control unit terminal ⑤.

##### Passenger side door

Power is supplied

- to passenger side door lock actuator terminal ①
- through smart entrance control unit terminal ②.

Ground is supplied

- to passenger side door lock actuator terminal ③
- through smart entrance control unit terminal ④.

Then, the door is unlocked.

## POWER DOOR LOCK

### System Description (Cont'd)

(Lock)

Driver side door (Models with multi-remote control system)

is supplied

Driver side door lock actuator terminal ③

High smart entrance control unit terminal ⑤.

The door is locked.

is supplied

Driver side door lock actuator terminal ①

High smart entrance control unit terminal ③.

Passenger side door

is supplied

Passenger side door lock actuator terminal ③

High smart entrance control unit terminal ④.

is supplied

Passenger side door lock actuator terminal ①

High smart entrance control unit terminal ②.

The door is locked.

## POWER DOOR LOCK

### Wiring Diagram — D/LOCK —

EL-D/LOCK-01

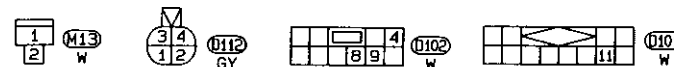
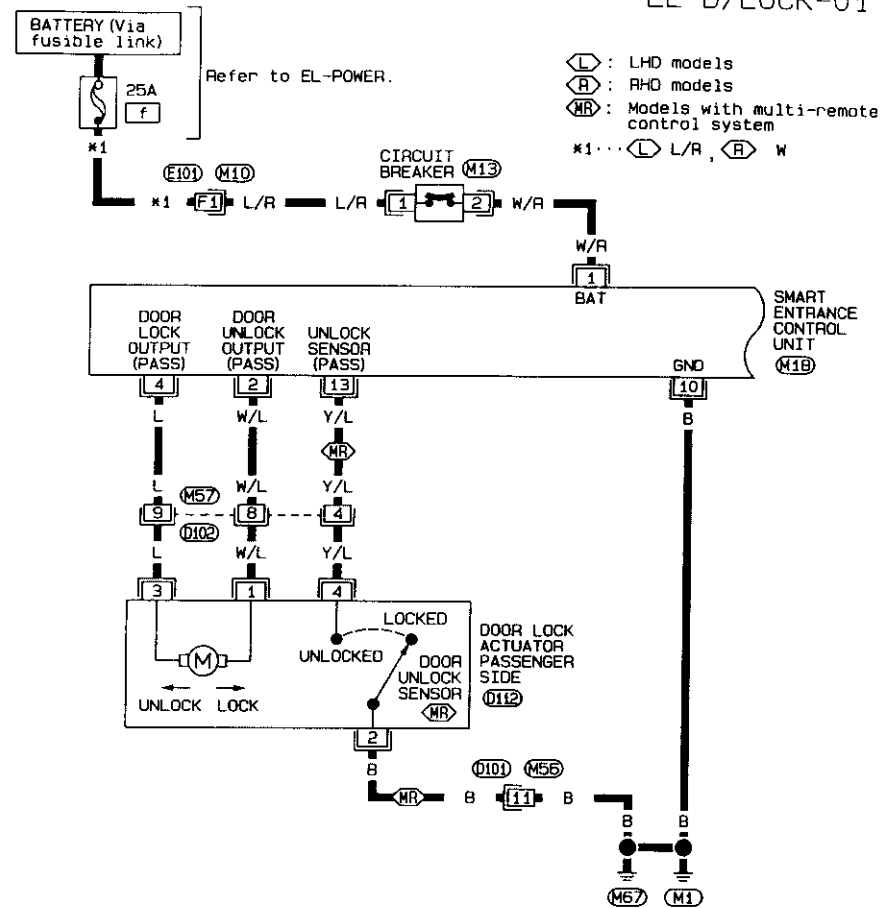

Refer to last page (Foldout page).

M10, E101  
M18

# POWER DOOR LOCK

## Wiring Diagram — D/LOCK — (Cont'd)

EL-D/LOCK-02

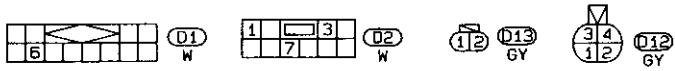
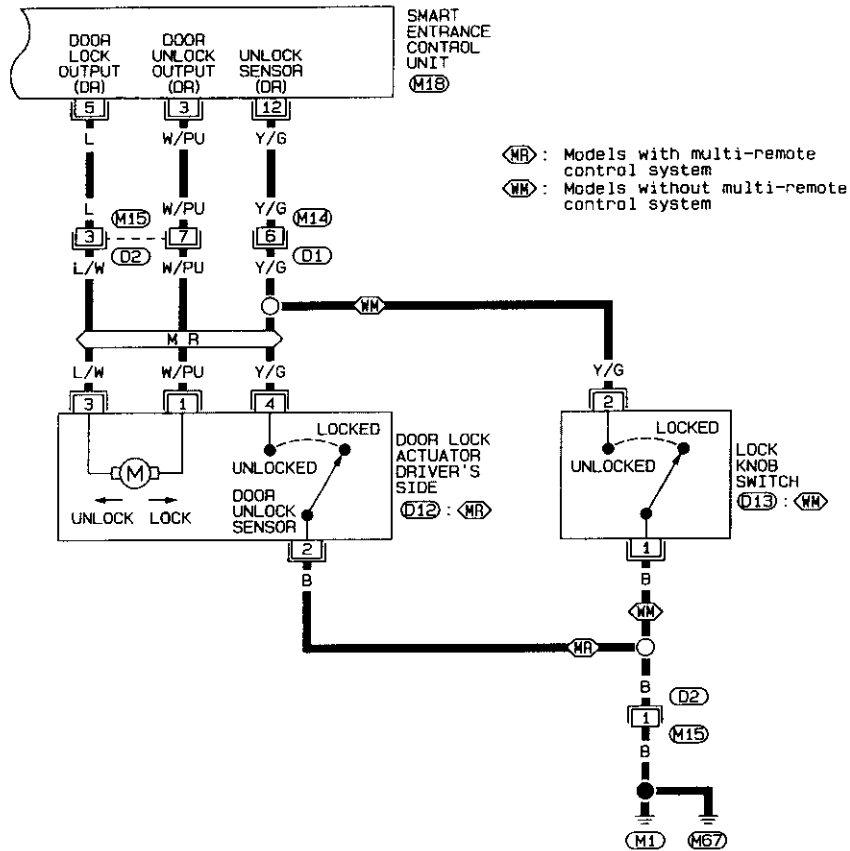

Refer to last page (Foldout page).

# POWER DOOR LOCK

## Trouble Diagnoses

### DIAGNOSTIC PROCEDURE

**SYMPTOM: Power door lock cannot be operated.**

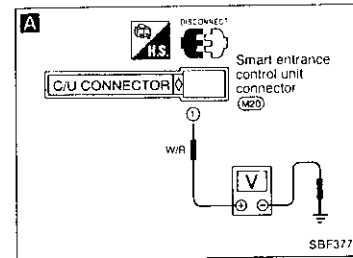

**A**

**CHECK MAIN POWER SUPPLY AND GROUND CIRCUIT.**

- 1) Disconnect connector from control unit.
- 2) Check voltage across control unit terminal ① and GND.

Does battery voltage exist?

No → Check the following.  
 • Fuse  
 • Circuit breaker  
 • Power supply harness

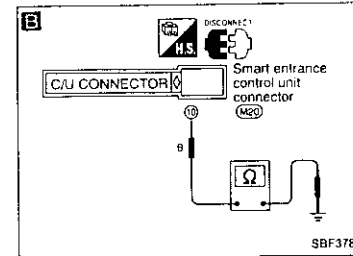

**B**

Check continuity between terminal ⑩ and GND.

Does continuity exist?

No → Check GND harness.

Yes →

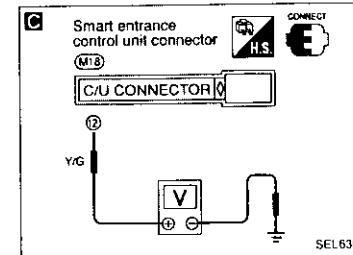

**C**

**CHECK UNLOCK SENSOR CIRCUIT.**

- 1) Connect control unit connector.
- 2) Check voltage across control unit terminal ⑫ and GND.

Driver side door lock knob condition	Terminals	Voltage (V)
Locked → Unlocked	⑫ - GND	12 → 0
→ Locked		→ 12

OK →

NG →

**D**

- 1) Disconnect connector from control unit.
- 2) Check continuity between ⑫ and GND.

Driver side door lock knob condition	Terminals
Unlocked	⑫ - GND

Does continuity exist?

No →

Yes → Replace smart entrance control unit.

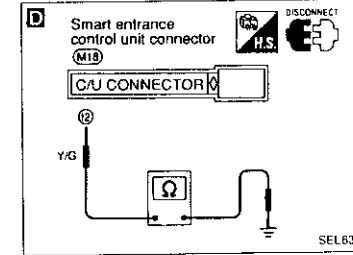

**E**

**CHECK DOOR LOCK ACTUATOR CIRCUIT.**

Check voltage for door lock motor.

Driver side door lock knob condition	Terminals
Locked	④ ②
Unlocked	② ④

Does battery voltage exist?

No →

Yes → Replace smart entrance control unit.

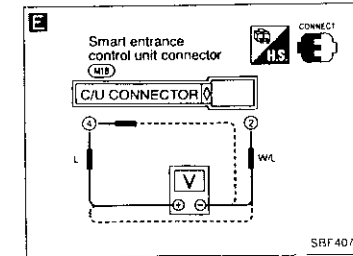

**E**

**CHECK DOOR LOCK ACTUATOR CIRCUIT.**

Check voltage for door lock motor.

Driver side door lock knob condition	Terminals
Locked	④ ②
Unlocked	② ④

Does battery voltage exist?

No →

Yes → Replace smart entrance control unit.

(Go to next page)

## POWER DOOR LOCK

### Trouble Diagnoses (Cont'd)

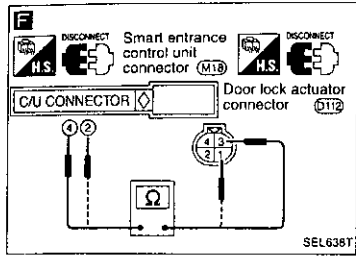

SEL638T

**F**

- 1) Disconnect control unit connector and door lock actuator connector.
- 2) Check continuity.

Terminals	Continuity
④ - ③	Yes
② - ①	

Does continuity exist?

Yes

Check power door lock motor.  
Refer to "ELECTRICAL COMPONENTS INSPECTION".

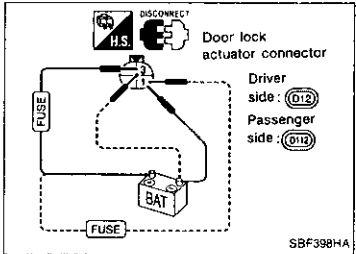

SBF398HA

### ELECTRICAL COMPONENTS INSPECTION

#### Power door lock motor

Door lock condition	Terminals	
	+	-
Unlocked → Locked	③	①
Locked → Unlocked	①	③

EL-174

## POWER DOOR MIRROR

★ For removal of door mirror, refer to "DOOR MIRROR" in BT section.

### Wiring Diagram — MIRROR —

LHD MODELS

EL-MIRROR-01

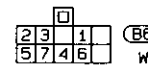
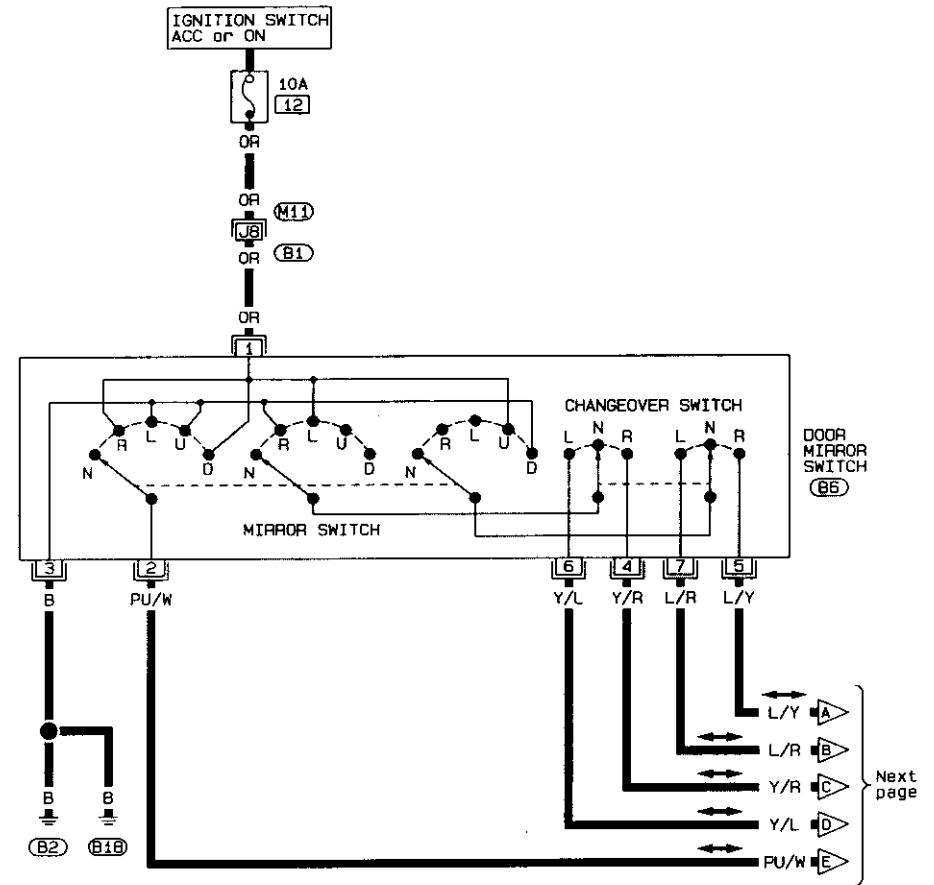

Refer to last page (Foldout page).

(M11) (B1)

EL-175

SEL753T

GI  
MA  
EM  
LC  
EC  
FE  
CL  
MT  
AT  
PD  
FA  
RA  
BR  
ST  
RS  
BT  
HA  
EL  
DX

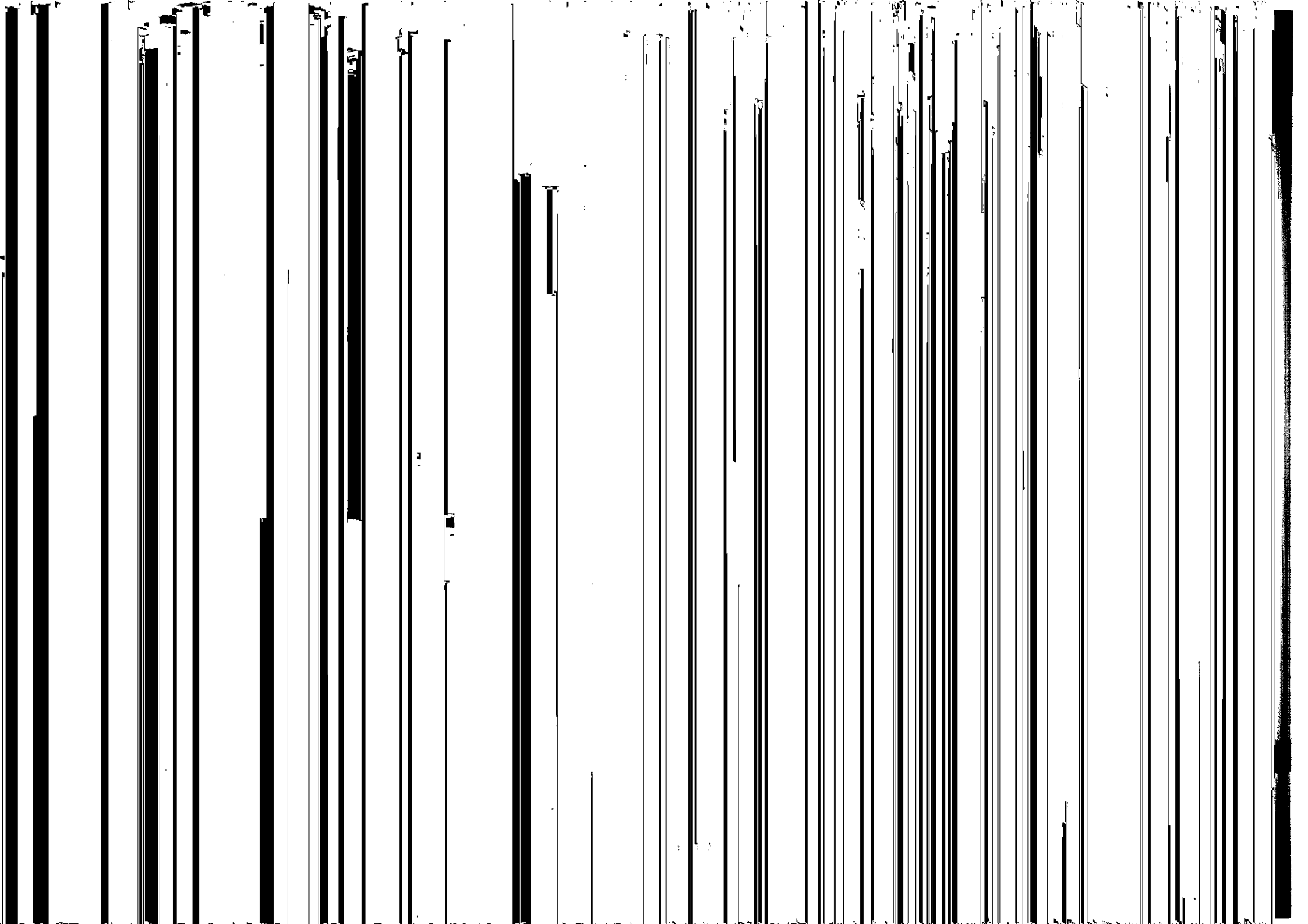





**ELECTRIC SUN ROOF**  
Wiring Diagram — SROOF — (Cont'd)

EL-SROOF-02

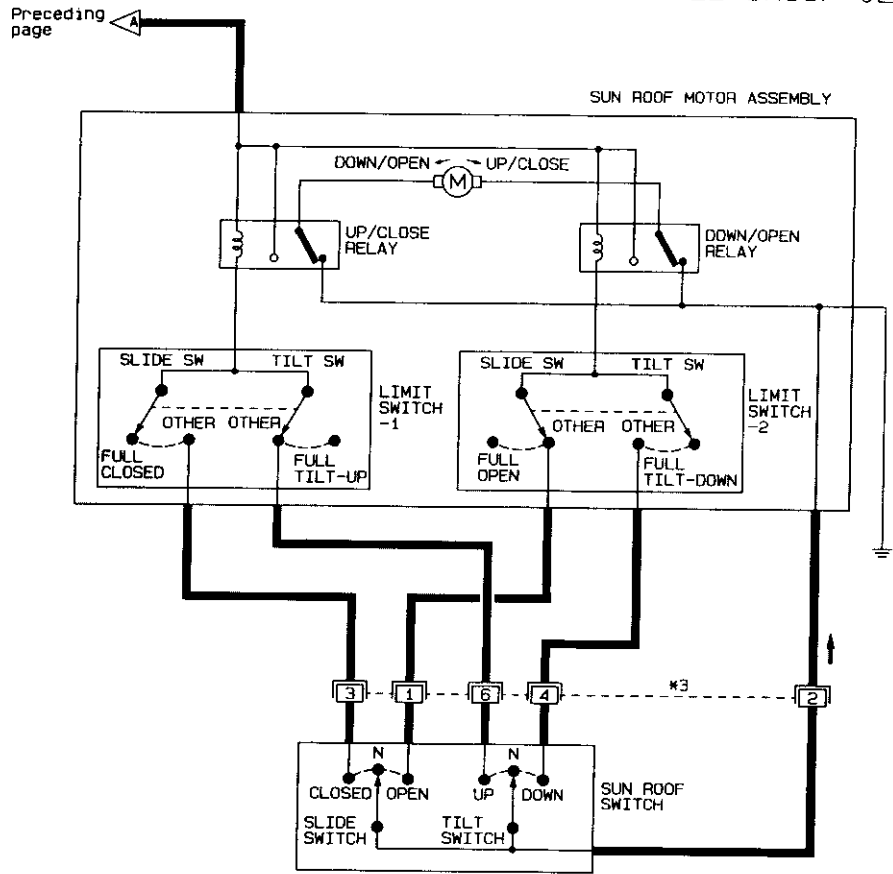

4	0	1
2	6	3

\*3 BR

EL-180

SEL 756T

**HORN, CIGARETTE LIGHTER AND CLOCK**

Wiring Diagram — HORN —

LHD MODELS

EL-HORN-01

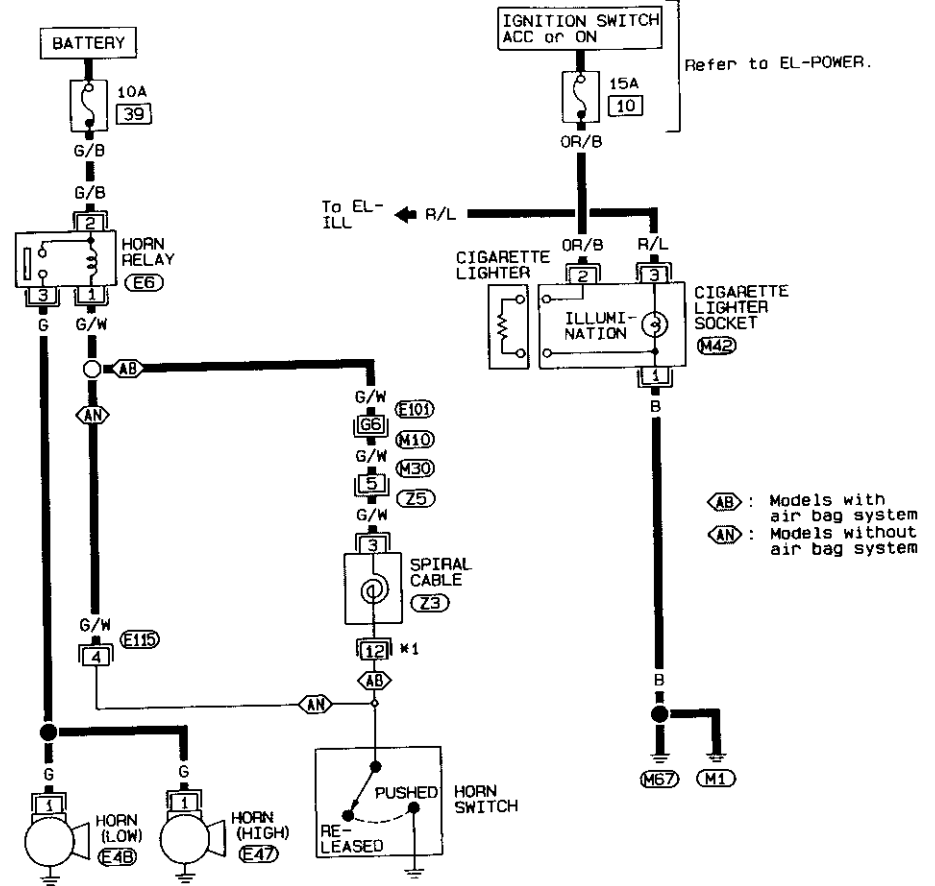

Refer to EL-POWER.

AB: Models with air bag system  
AN: Models without air bag system

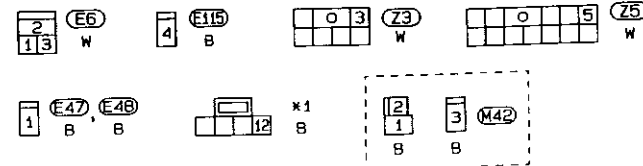

Refer to last page (Foldout page).

M10, E101

EL

EL-181

SEL 757T

# HORN, CIGARETTE LIGHTER AND CLOCK

## Wiring Diagram — HORN — (Cont'd)

EL-HORN-02

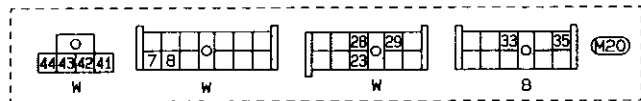
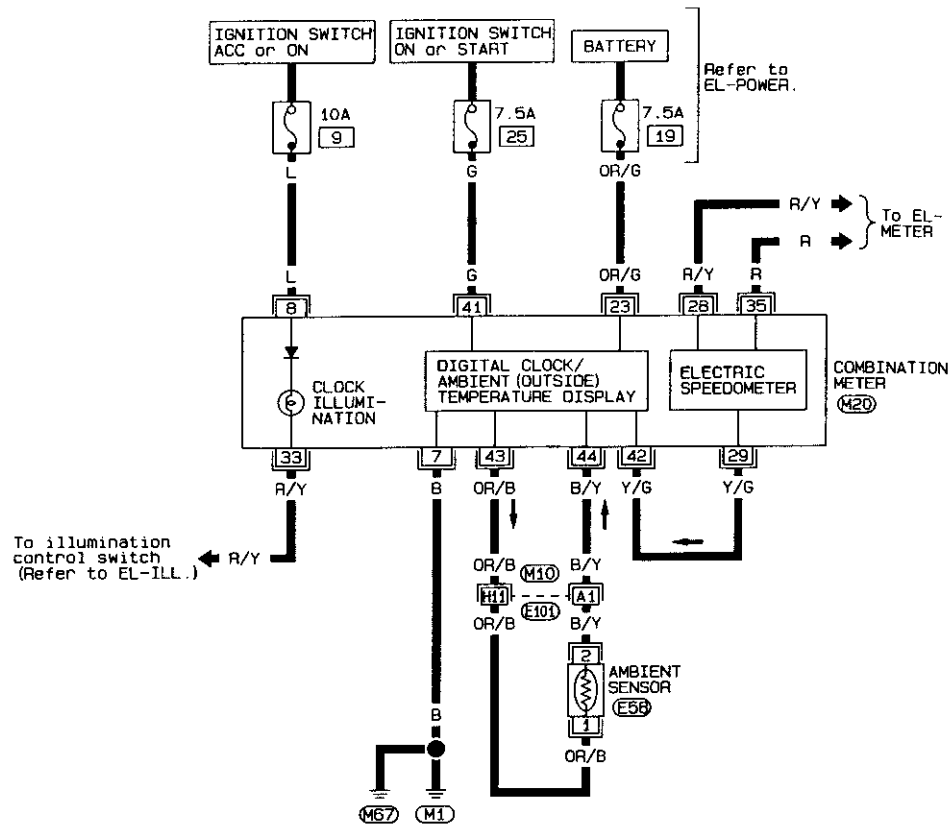

Refer to last page (Foldout page).

M10, E101

# HORN, CIGARETTE LIGHTER AND CLOCK

## Wiring Diagram — HORN — (Cont'd)

RHD MODELS

EL-HORN-03

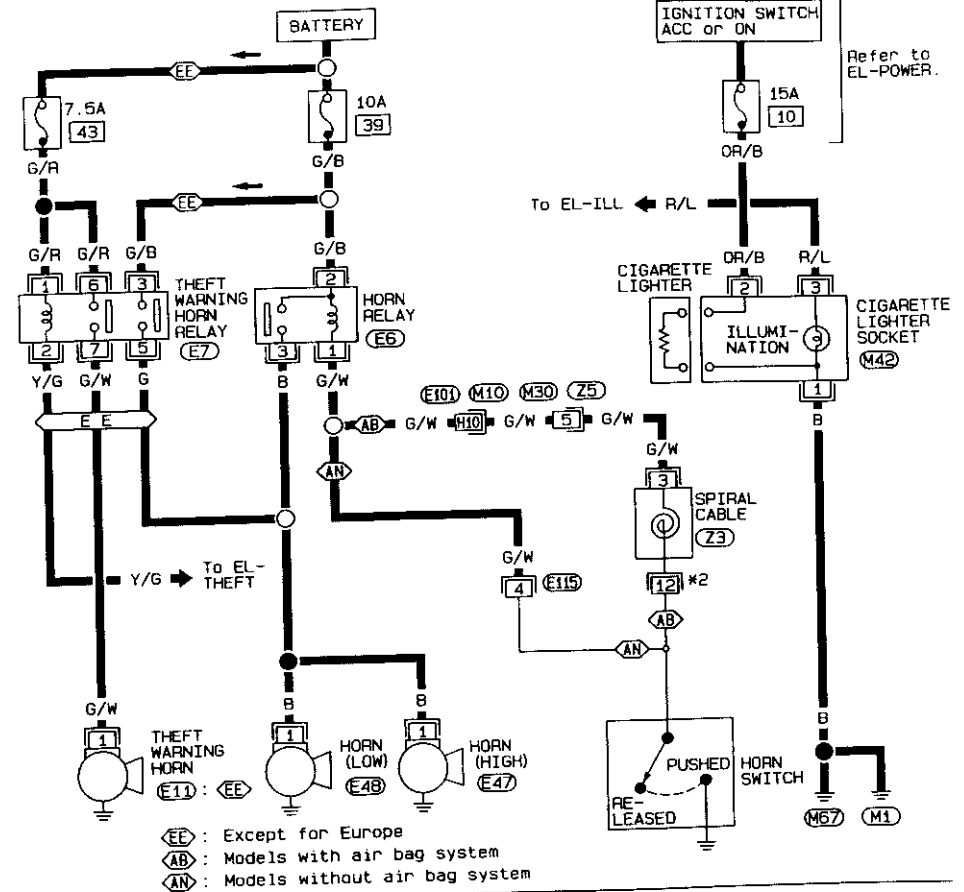

- EE: Except for Europe
- AB: Models with air bag system
- AN: Models without air bag system

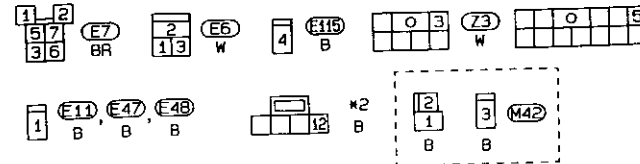

Refer to last page (Foldout page).

M10, E101



# REAR WINDOW DEFOGGER AND DOOR MIRROR DEFOGGER

Wiring Diagram — DEF —

EL-DEF-01

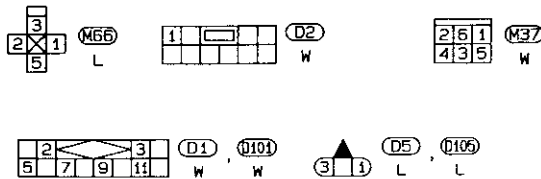
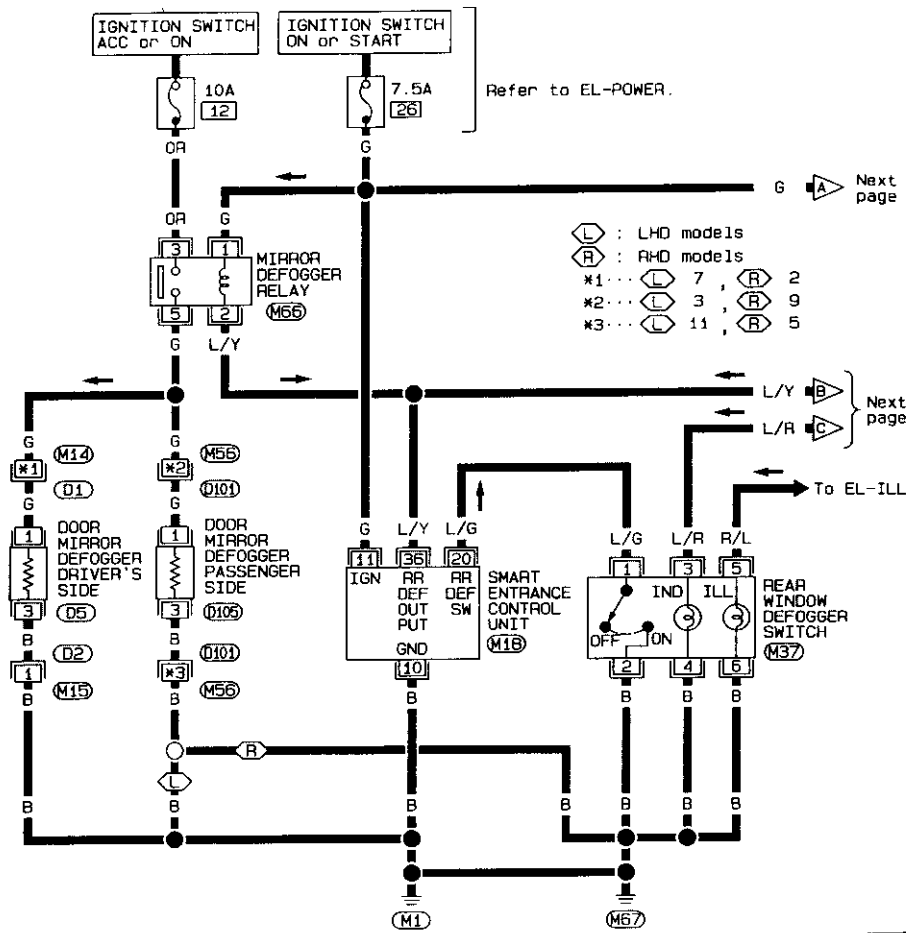

EL-186

SEL7611

# REAR WINDOW DEFOGGER AND DOOR MIRROR DEFOGGER

Wiring Diagram — DEF — (Cont'd)

EL-DEF-02

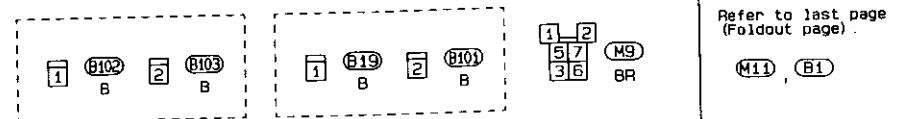
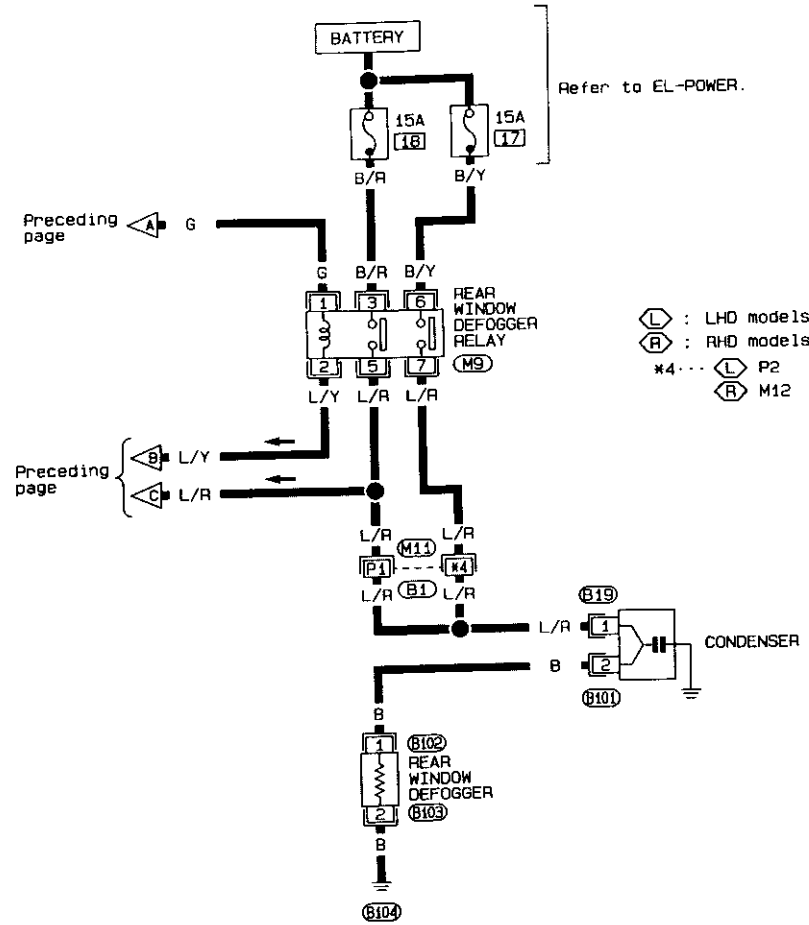

EL-187

SEL762T

EL

Trouble Diagnoses

DIAGNOSTIC PROCEDURE 1

**SYMPTOM:** Rear defogger does not activate, or does not go off after activating.

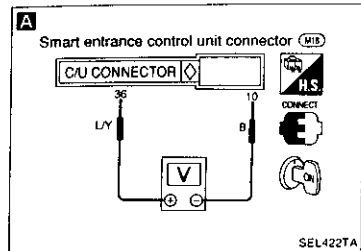

SEL422TA

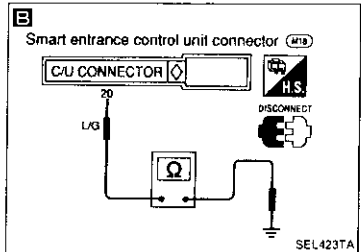

SEL423TA

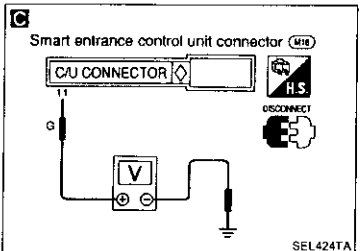

SEL424TA

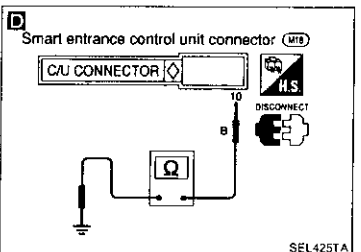

SEL425TA

**REAR WINDOW DEFOGGER OUTPUT SIGNAL CHECK**  
Measure voltage between control unit harness terminals ③ and ⑩.

Condition	Voltage [V]
Rear defogger switch is "OFF"	Approx. 12
Rear defogger switch is "ON"	0

- OK →
- Check rear window defogger relay. (Refer to EL-189.)
  - Check rear window defogger circuit.
  - Check rear window defogger filament. (Refer to EL-189.)

**REAR WINDOW DEFOGGER SWITCH INPUT SIGNAL CHECK**  
Check continuity between control unit harness terminal ② and body ground.

Condition of defogger switch	Continuity
Rear defogger switch is pushed.	Yes
Rear defogger switch is released.	No

- NG →
- Check rear window defogger switch. (Refer to EL-189.)
  - Check continuity between control unit harness terminal ② and rear window defogger switch harness terminal ①. **Continuity should exist.**
  - Check continuity between rear window defogger switch harness terminal ② and body ground. **Continuity should exist.**

**IGNITION INPUT SIGNAL CHECK**  
Check voltage between control unit harness terminal ⑪ and body ground.

Condition	Voltage [V]
Ignition switch is "ON"	Approx. 12
Ignition switch is "OFF"	0

- NG → Repair harness or connectors.

**CONTROL UNIT GROUND CIRCUIT CHECK**  
Check continuity between control unit harness terminal ⑩ and body ground. **Continuity should exist.**

- NG → Repair harness or connectors.

OK → Replace control unit

Trouble Diagnoses (Cont'd)

ELECTRICAL COMPONENTS INSPECTION

Rear window defogger relay

Check continuity between terminals ③ and ⑤, ⑥ and ⑦.

Condition	Continuity
12V direct current supply between terminals ① and ②	Yes
No current supply	No

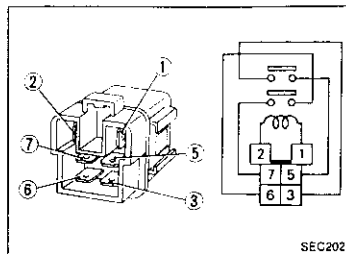

SEC202B

Rear window defogger switch

Check continuity between terminals when rear window defogger switch is pushed and released.

Terminals	Condition	Continuity
① - ②	Rear window defogger switch is pushed	Yes
	Rear window defogger switch is released	No

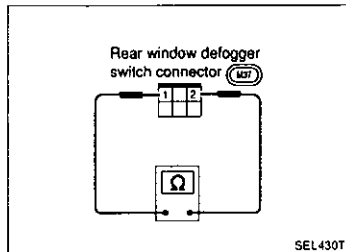

SEL430TA

Filament Check

1. Attach probe circuit tester (in volt range) to middle portion of each filament.

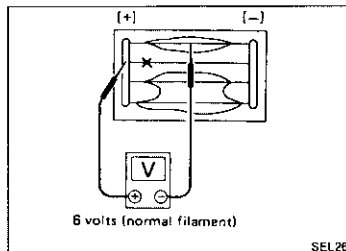

SEL263

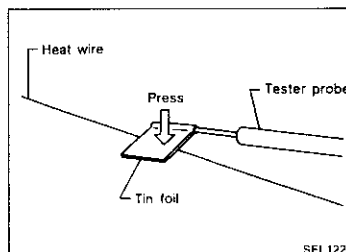

SEL122R

- When measuring voltage, wrap tin foil around the top of the negative probe. Then press the foil against the wire with your finger.



# AUDIO AND POWER ANTENNA

Audio/Wiring Diagram — AUDIO — (Cont'd)

EL-AUDIO-02

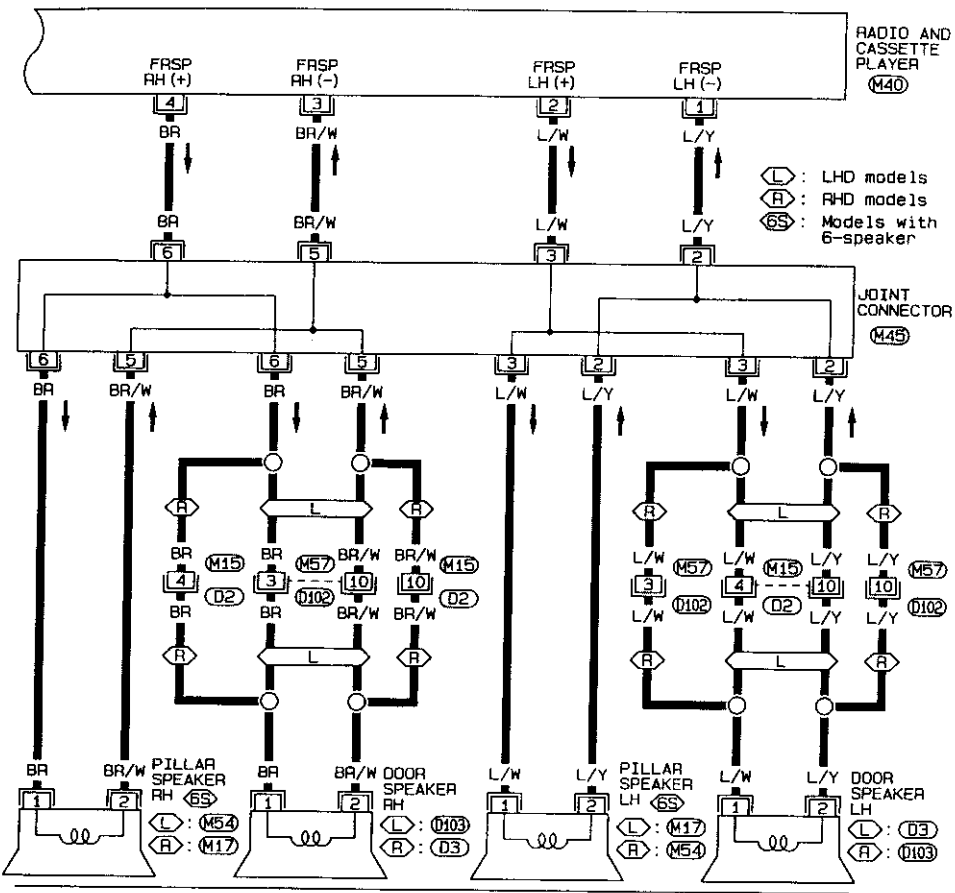

(L) : LHD models  
 (R) : RHD models  
 (6S) : Models with 6-speaker

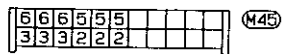
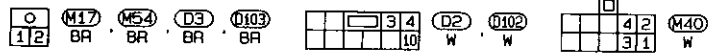

# AUDIO AND POWER ANTENNA

Audio/Wiring Diagram — AUDIO — (Cont'd)

FOR CENTRAL AND SOUTH AMERICA

EL-AUDIO-03

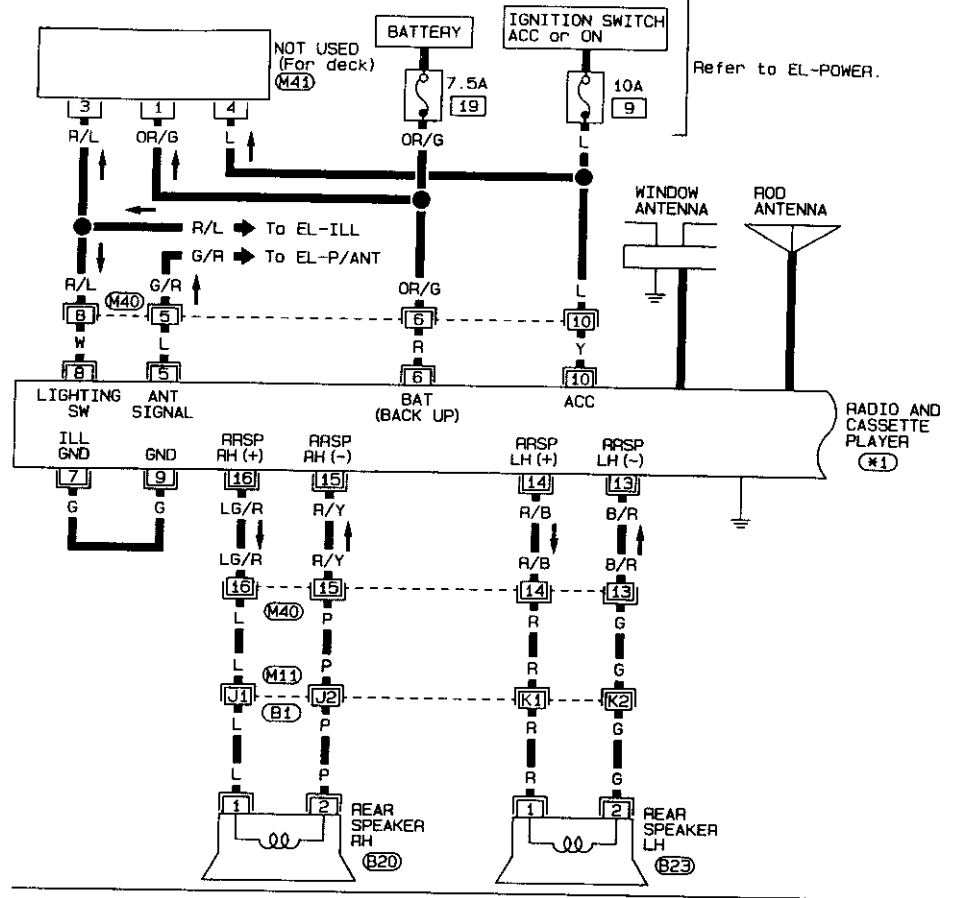

Refer to EL-POWER.

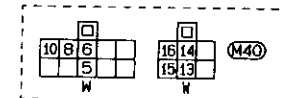
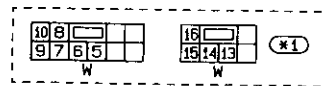

Refer to last page (Foldout page).

(M1), (B1)

# AUDIO AND POWER ANTENNA

## Audio/Wiring Diagram — AUDIO — (Cont'd)

EL-AUDIO-04

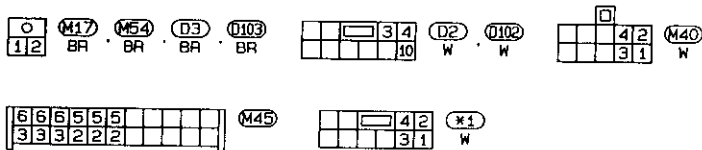
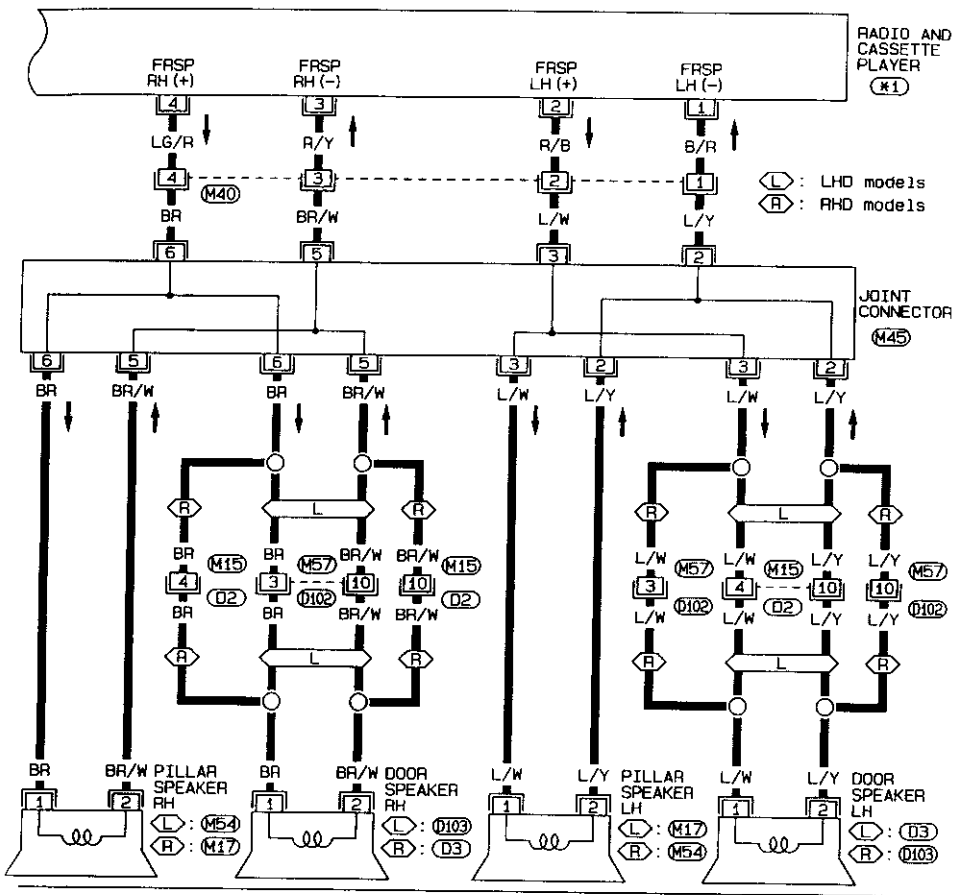

# AUDIO AND POWER ANTENNA

## Audio

### ANTI-THEFT SYSTEM

By using a personal 4-digit code known only to the vehicle owner, the possibility of the audio unit being stolen is effectively reduced, because without the code the unit can not be activated. When in normal use, the unit is unlocked and accessible in the usual way.

If however, someone attempts to remove the unit or the ground cable is disconnected from the battery, the Anti-theft system activates and the unit "locks". The only way it can be unlocked is by entering a personal code number known only by the owner.

### UNLOCKING THE UNIT (How to enter a personal code number)

Use the following procedures to enter a personal code number into the radio.

1. Turn ignition switch to "ACC" or "ON".
2. Turn SW. VOL knob to "ON" and "0000" will appear on the display.
3. Press any button (except "eject") and "0000" will appear on the display.
4. Enter a personal code number by pressing station select buttons 1, 2, 3, 4 the required number of times to display the code.
5. Press to enter the code.

Unit is unlocked and the radio/cassette will operate.

If the wrong code number is entered, the display shows "----". Wait ten seconds then enter the correct code.

### CAUTION:

There is a theft prevention mechanism restricting the number of times a wrong code number can be entered into the radio unit. If a wrong code number is entered 1 to 2 times, you will have to wait for 10 seconds before the radio will receive further input. If a wrong code number is entered 3 to 20 times, you will have to wait a duration of 15 minutes. The radio unit will lock permanently if any further attempts are made.

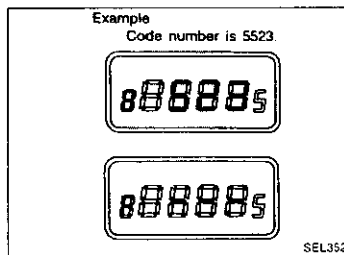
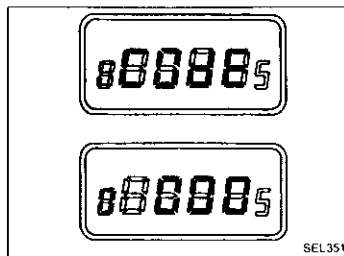
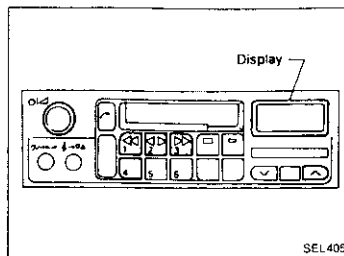

### Radio Fuse Check

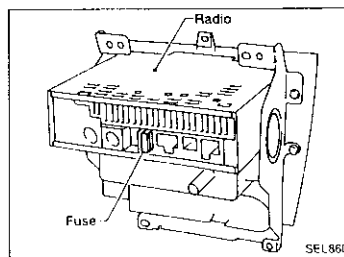



Power Antenna/Wiring Diagram — P/ANT —

EL-P/ANT-01

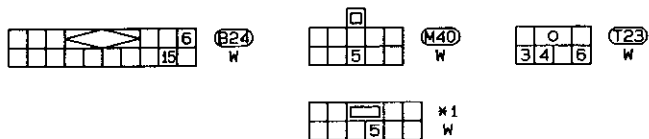
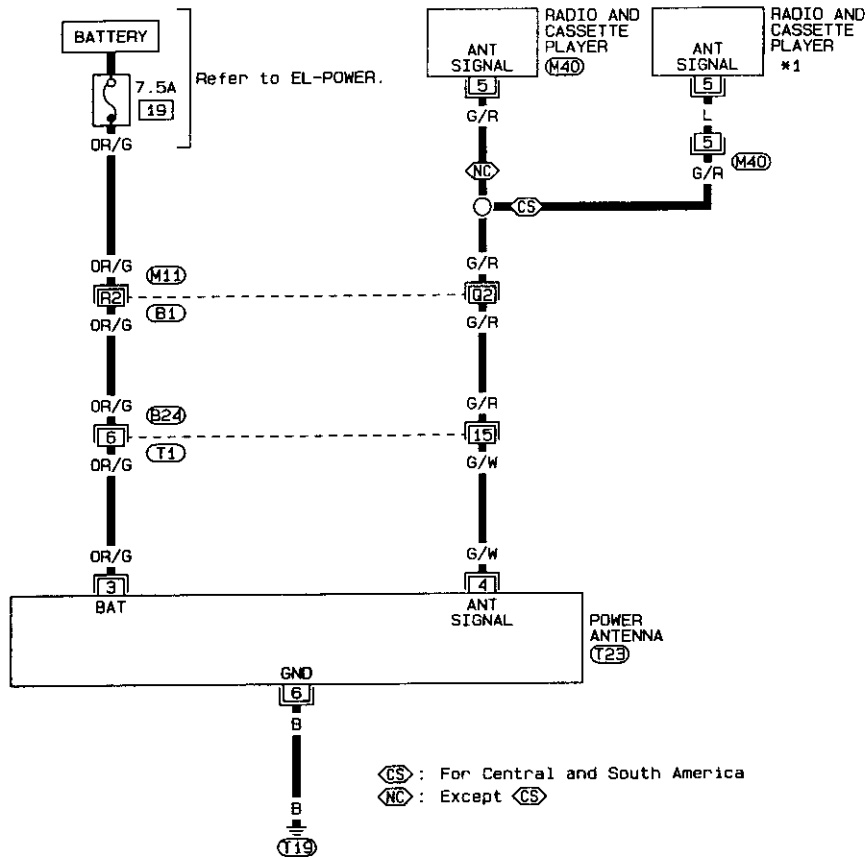

Refer to last page (foldout page).

(M11), (B1)

Location of Antenna

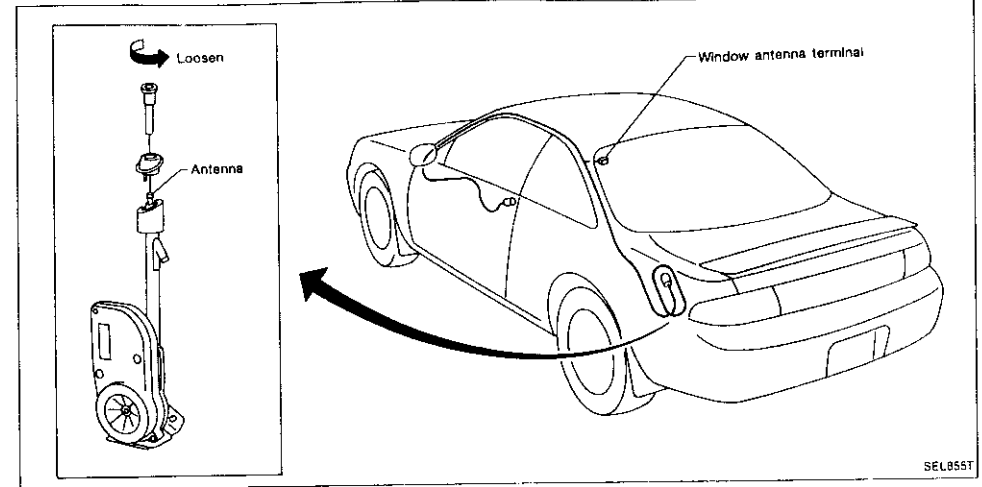

Antenna Rod Replacement

REMOVAL

1. Remove antenna nut and antenna base.

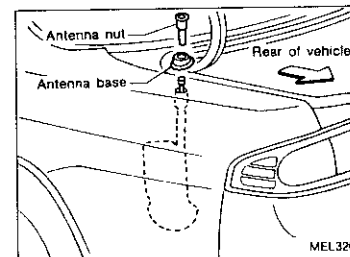

2. Withdraw antenna rod while raising it by operating antenna motor.

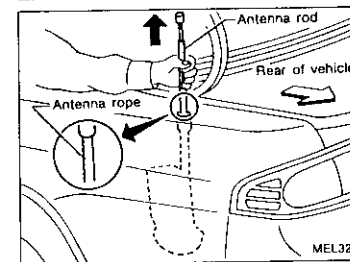

## AUDIO AND POWER ANTENNA

### Antenna Rod Replacement (Cont'd)

#### INSTALLATION

1. Lower antenna rod by operating antenna motor.
2. Insert gear section of antenna rope into place with it facing toward antenna motor.
3. As soon as antenna rope is wound on antenna motor, stop antenna motor. Insert antenna rod lower end into antenna motor pipe.
4. Retract antenna rod completely by operating antenna motor.
5. Install antenna nut and base.

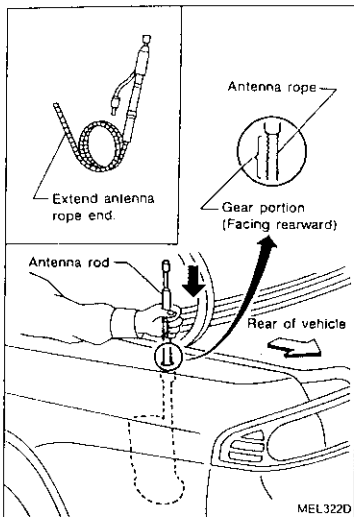

### Window Antenna Repair

#### ELEMENT CHECK

1. Attach probe circuit tester (in ohm range) to antenna terminal on each side.
2. If an element is broken, no continuity will exist.

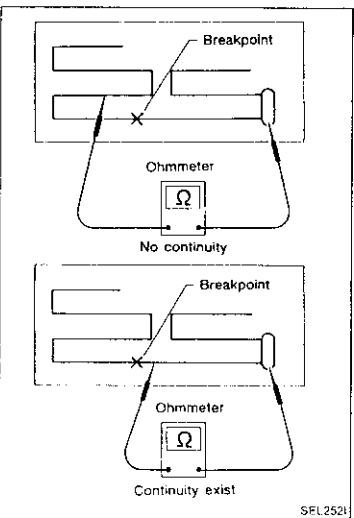
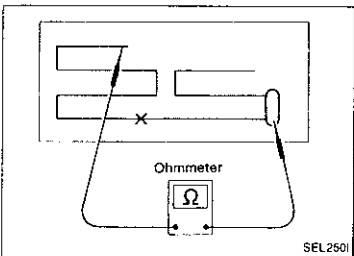

## AUDIO AND POWER ANTENNA

### Window Antenna Repair (Cont'd)

3. To locate broken point, move probe to left and right along element. Tester needle will swing abruptly when probe passes the point.
- Refer to REAR WINDOW DEFOGGER "Filament Repair" for Element Repair.

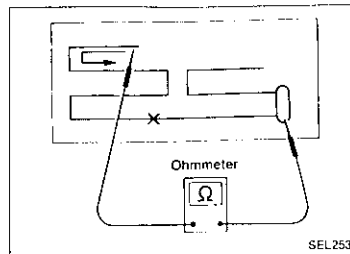

# HEATED SEAT

★ For location of heating unit, refer to "SEAT" in BT section.

## Wiring Diagram — H/SEAT —

EL-H/SEAT-01

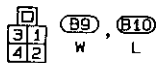
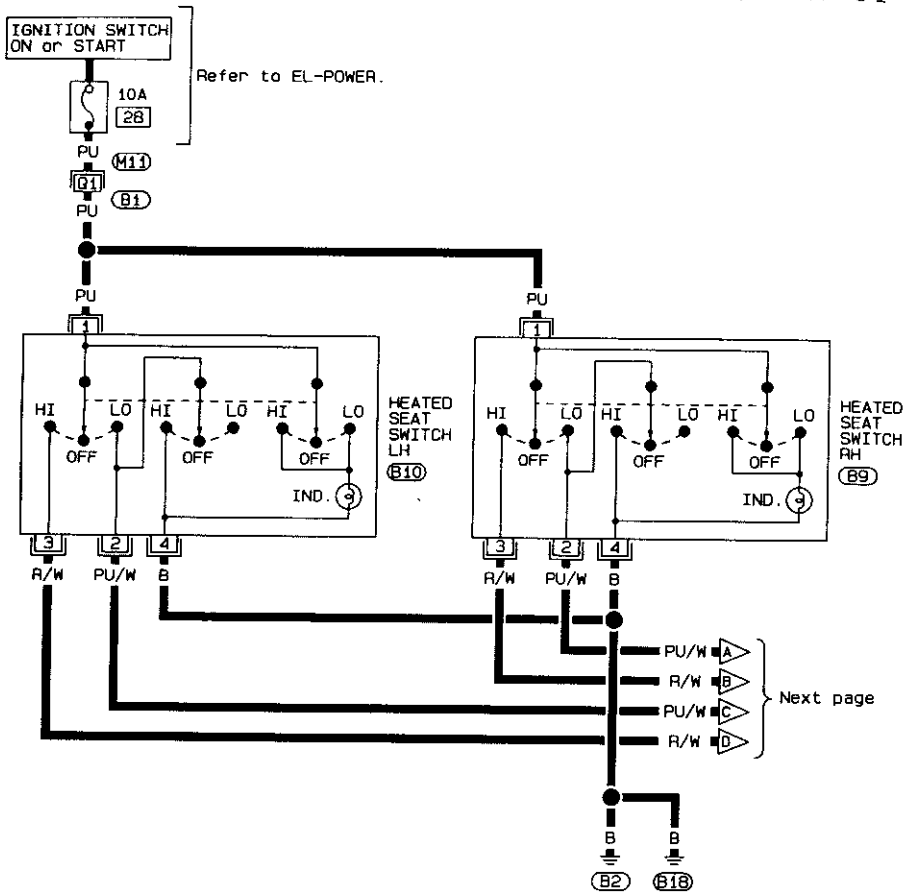

Refer to last page (Foldout page).

M11, B1

# HEATED SEAT

## Wiring Diagram — H/SEAT — (Cont'd)

EL-H/SEAT-02

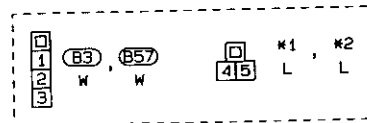
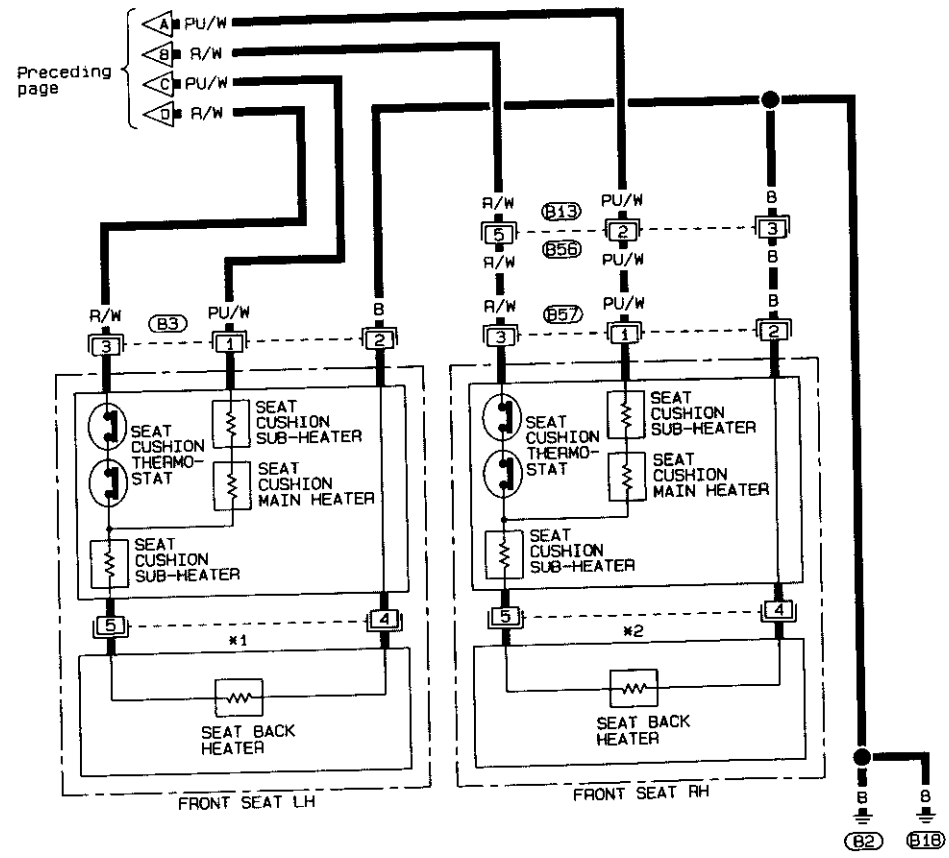

at  
rom  
42  
EM  
tem  
rom  
10  
EG  
-E  
gnal  
GL  
Vtr  
LING  
AT  
PR  
14  
RA  
RH  
ST  
14  
ST  
14  
EL  
100

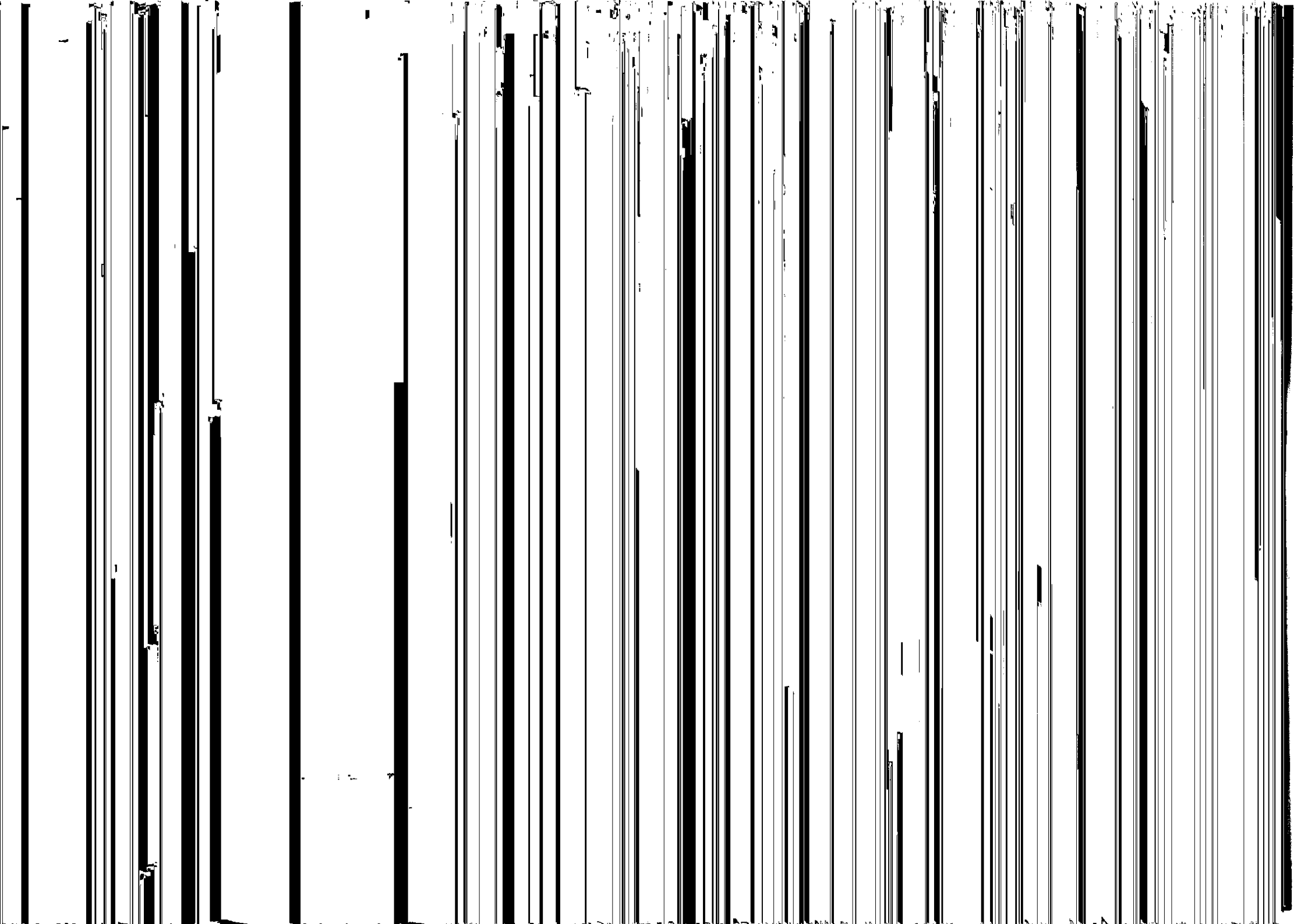

# MULTI-REMOTE CONTROL SYSTEM

## Wiring Diagram — MULTI —

EL-MULTI-01

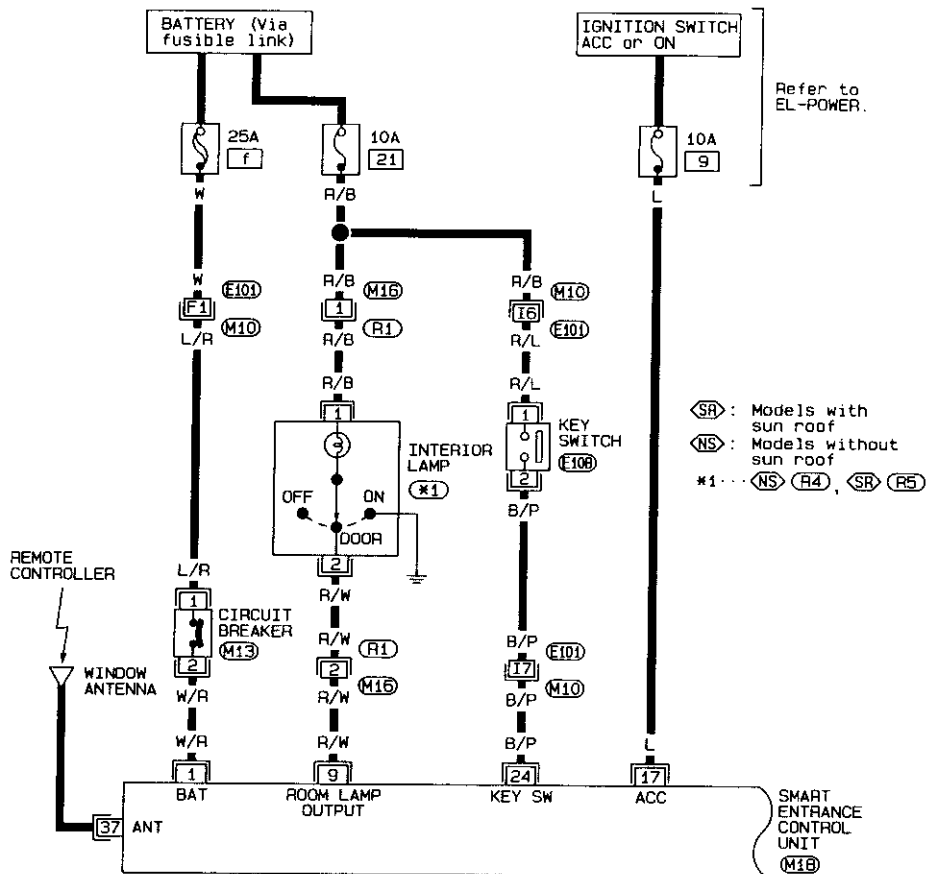

Refer to EL-POWER.

- ⊖SR: Models with sun roof
- ⊖NS: Models without sun roof
- \*1...⊖NS ⊖R4, ⊖SR ⊖R5

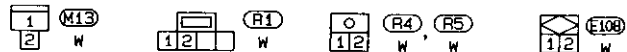

Refer to last page (Foldout page).

- ⊖M10, ⊖E101
- ⊖M18

# MULTI-REMOTE CONTROL SYSTEM

## Wiring Diagram — MULTI — (Cont'd)

EL-MULTI-02

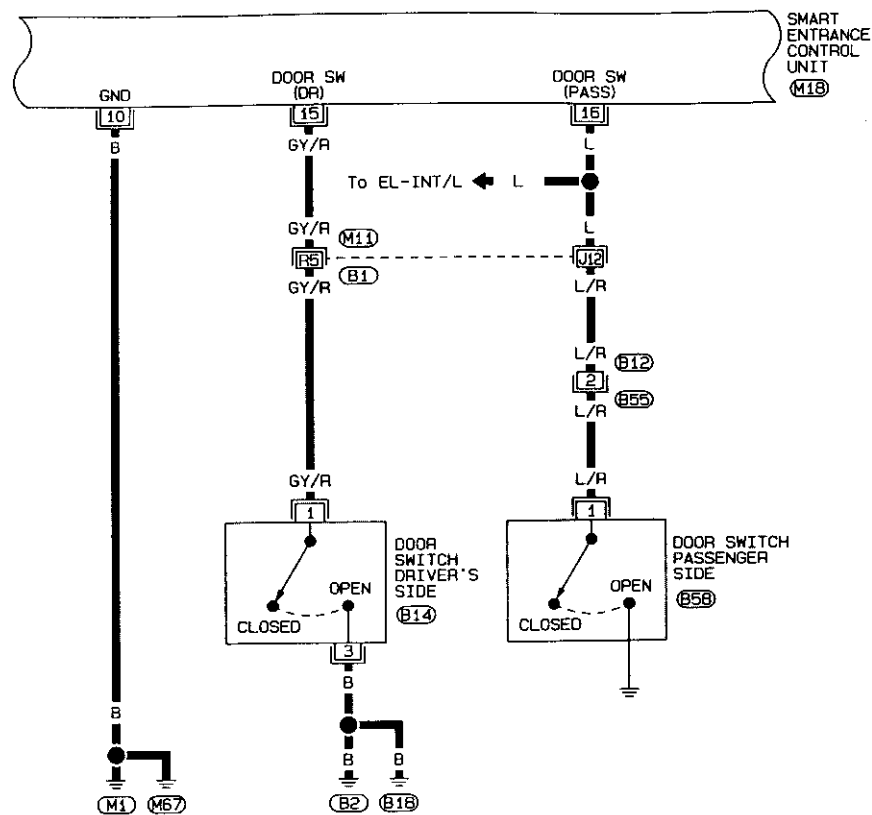

Refer to last page (Foldout page).

- ⊖M11, ⊖B1
- ⊖M18

# MULTI-REMOTE CONTROL SYSTEM

## Wiring Diagram — MULTI — (Cont'd)

EL-MULTI-03

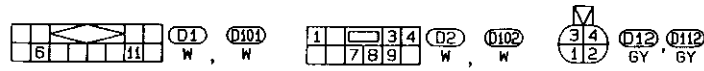
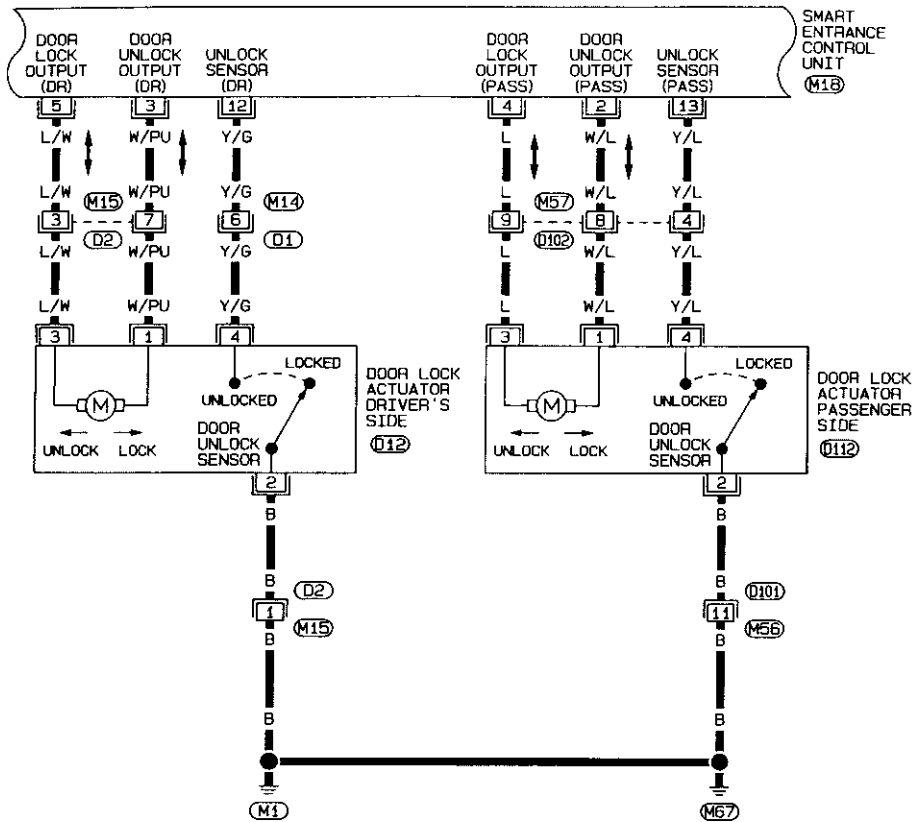

Refer to last page (Foldout page).

(M18)

# MULTI-REMOTE CONTROL SYSTEM

## Wiring Diagram — MULTI — (Cont'd)

EL-MULTI-04

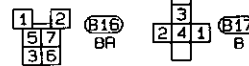
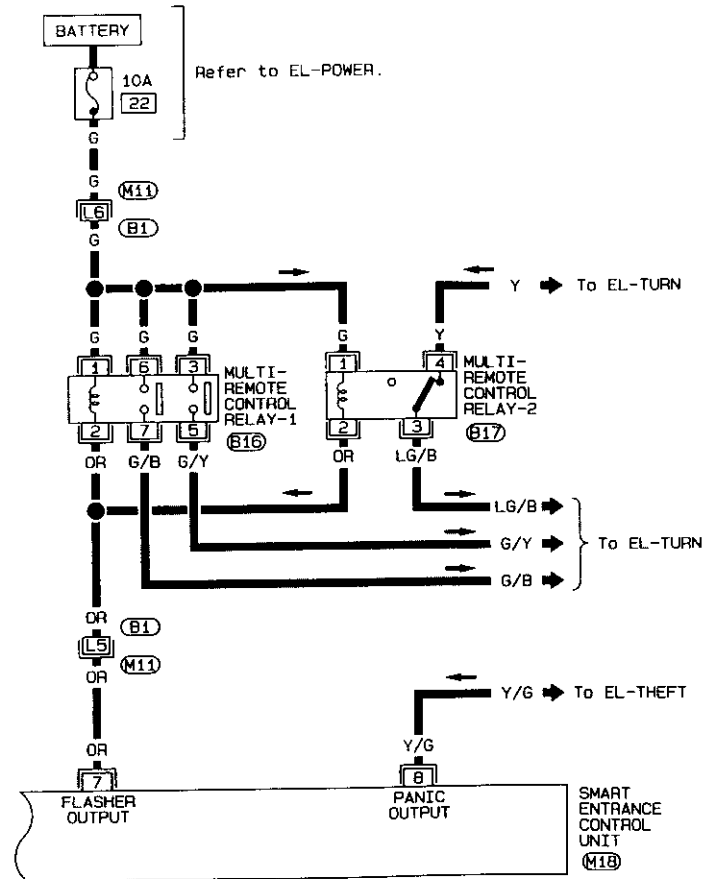

Refer to last page (Foldout page).

(M11), (B1)

(M18)

## MULTI-REMOTE CONTROL SYSTEM

### Input/Output Operation Signal

#### SMART ENTRANCE CONTROL UNIT

Terminal No.	Connections	Operated condition	Voltage (V) (Approximate values)
1	Power source (C/B)	—	12V
2	Passenger door lock motor	When door unlock signal is received from remote controller or unlock sensor	Unlocked
3	Driver door lock motor		Free
4	Passenger door lock motor	When door lock signal is received from remote controller or unlock sensor	Locked
5	Driver's door lock motor		Free
7	Multi-remote control relay 1	When doors are locked using remote controller or panic alarm is operated using remote controller	12V → 1V or less
8	Theft warning horn relay	When panic alarm is operated using remote controller	12V → 1V or less
9	Interior lamp	When doors are unlocked using remote controller. (Lamp switch in "DOOR" position)	12V → 1V or less
10	Ground	—	—
11	Ignition switch (ON)	"ON" or "START" position	12V
12	Driver door unlock sensor	Driver door: Locked → Unlocked	12V → 4.5V or less
13	Passenger door unlock sensor	Passenger door: Locked → Unlocked	12V → 4.5V or less
15	Driver door switch	OFF (Closed) → ON (Open)	12V → 4.5V or less
16	Passenger door switch	OFF (Closed) → ON (Open)	12V → 1.5V or less
17	Ignition switch (ACC)	"ACC" or "ON" position	12V
24	Ignition key switch (Insert)	IGN key inserted → IGN key removed from IGN key cylinder	12V → 4.5V or less
37	Multi-remote antenna	—	—

## MULTI-REMOTE CONTROL SYSTEM

### Trouble Diagnoses

#### TROUBLE SYMPTOM

- All functions of remote control system do not operate.

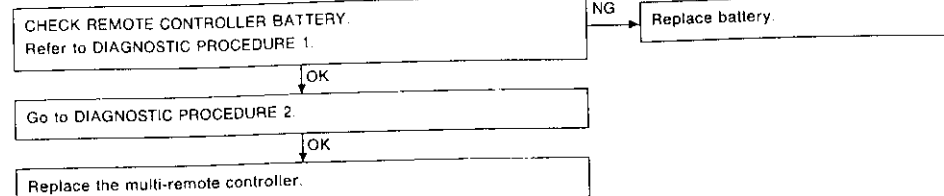

- Some functions of multi-remote controller do not operate.

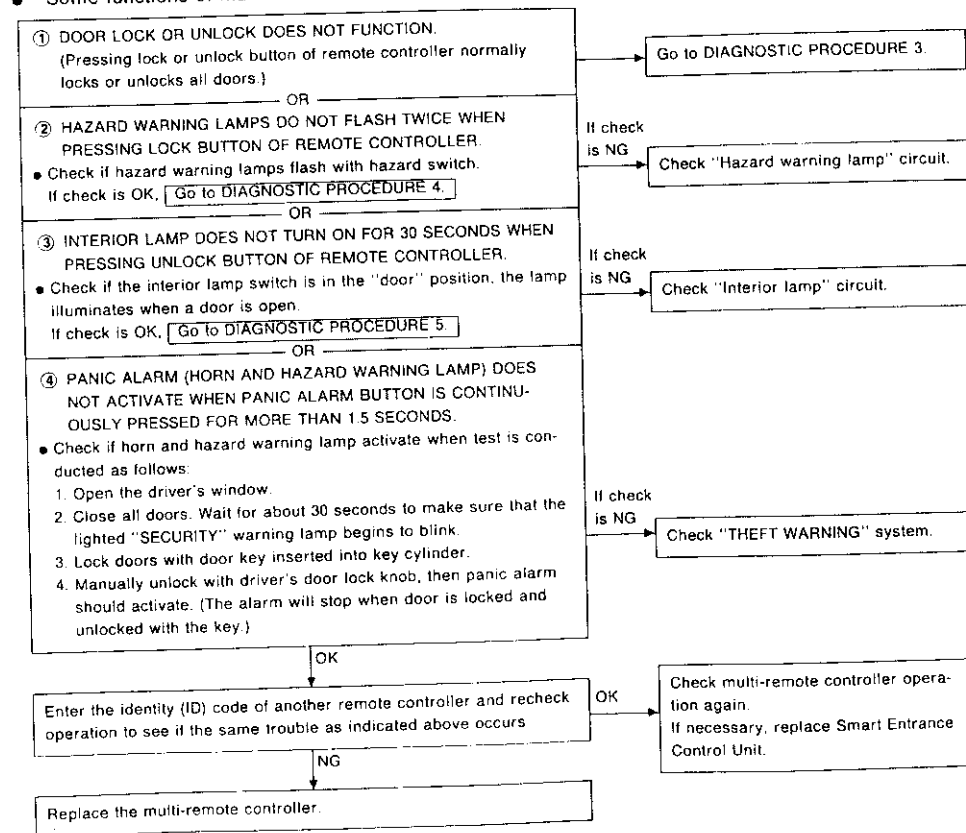

Note: The multi-remote control system does not activate with the ignition key inserted in the Ignition key cylinder.



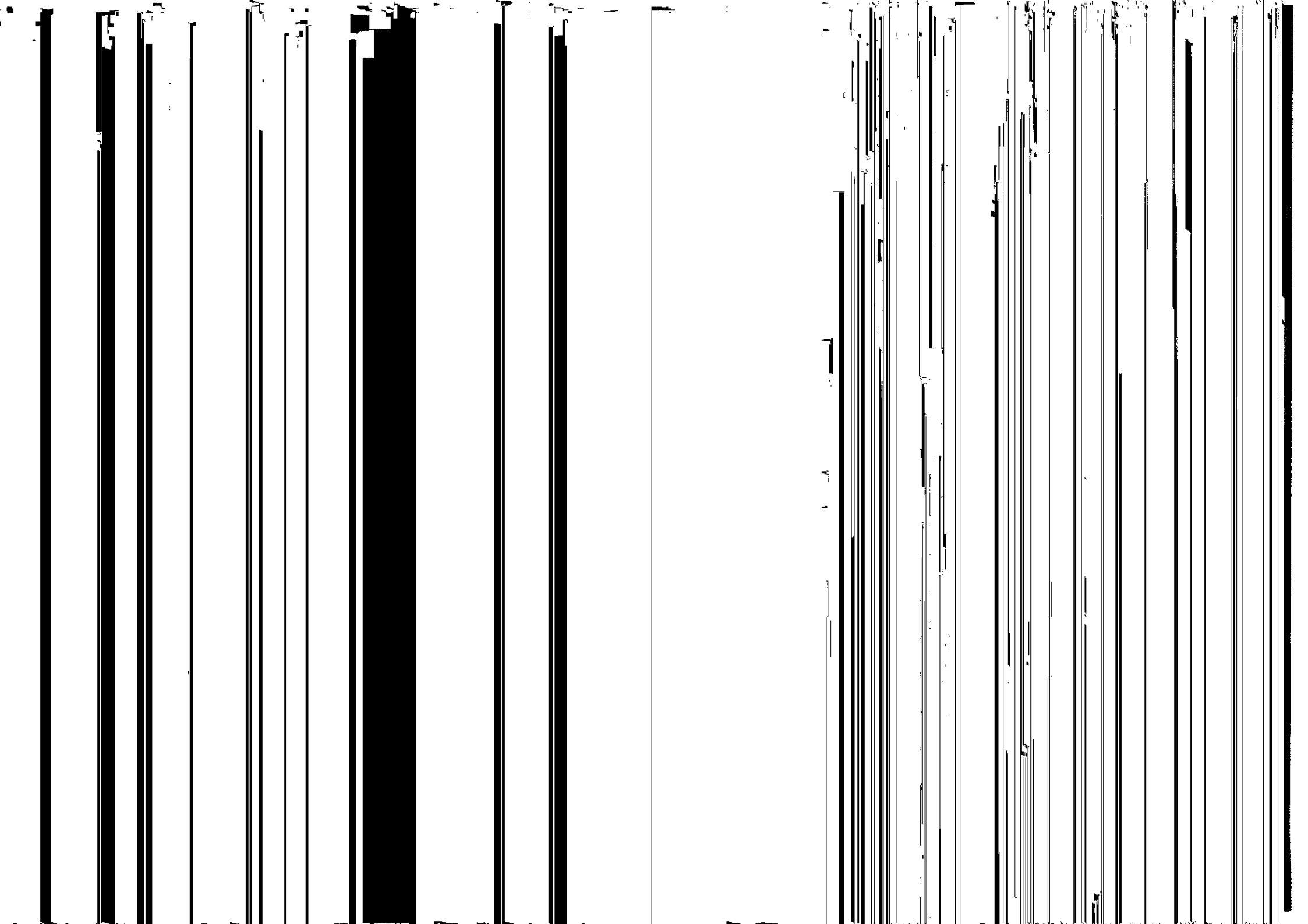

# MULTI-REMOTE CONTROL SYSTEM

## Trouble Diagnoses (Cont'd)

### DIAGNOSTIC PROCEDURE 3

SYMPTOM: Door lock or unlock on remote control does not function.

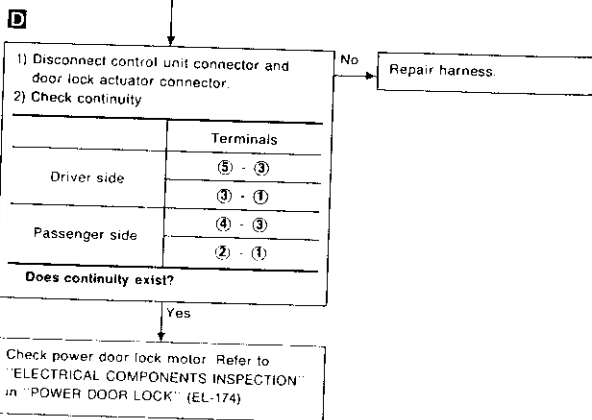
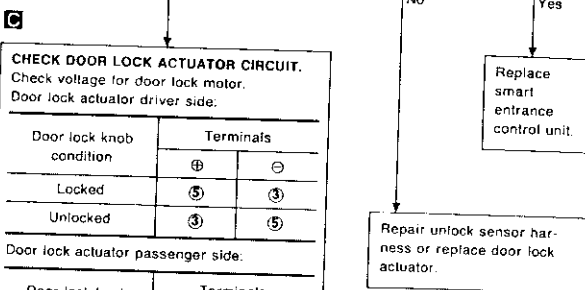
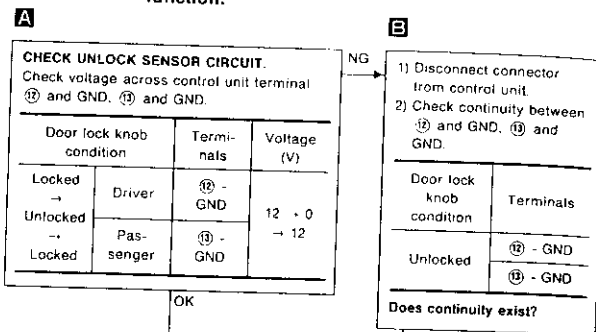
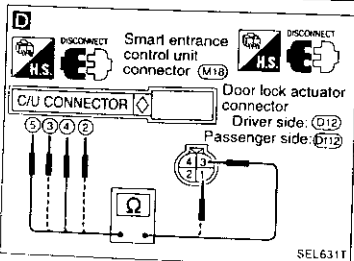
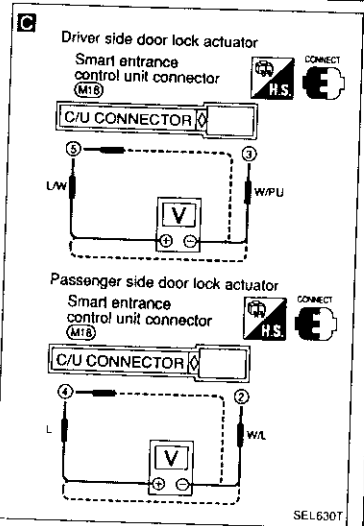
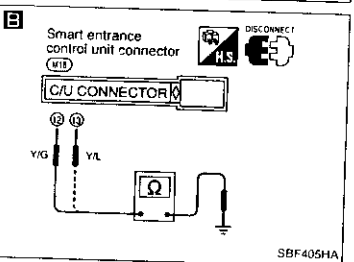
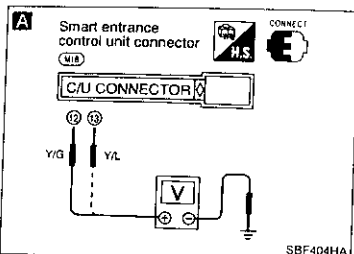

# MULTI-REMOTE CONTROL SYSTEM

## Trouble Diagnoses (Cont'd)

### DIAGNOSTIC PROCEDURE 4

SYMPTOM: Hazard warning lamps do not flash twice when pressing lock button of remote controller. Every-thing else functions.

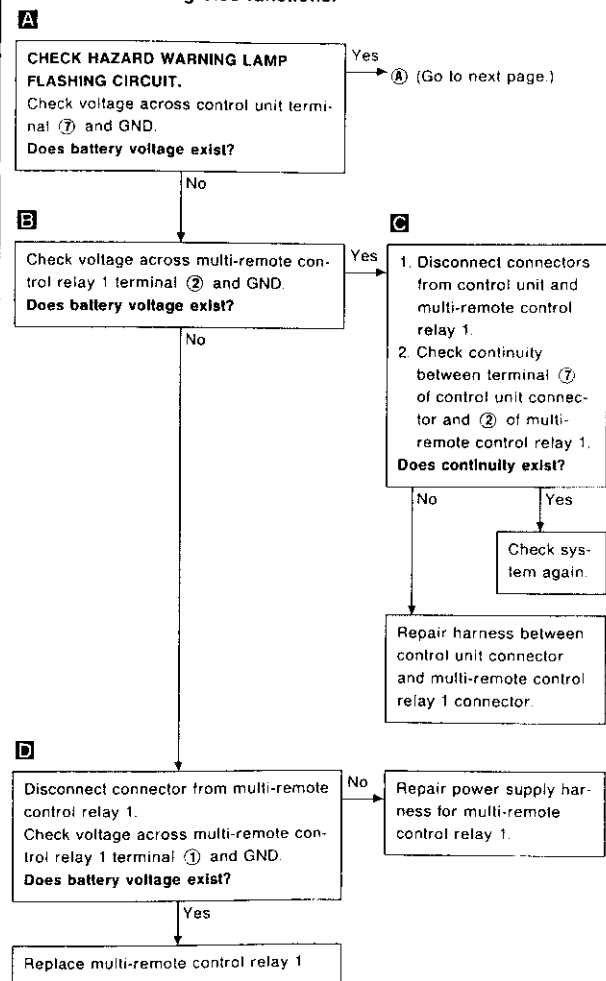
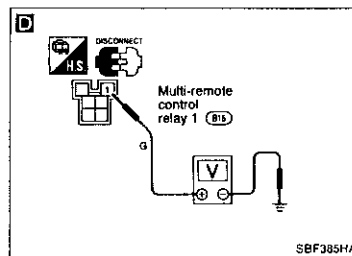
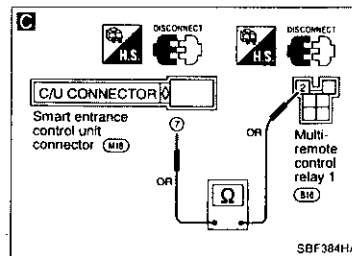
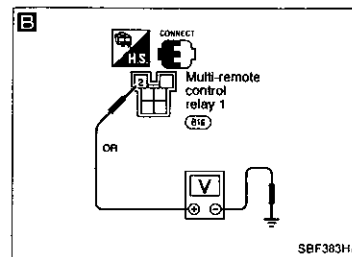
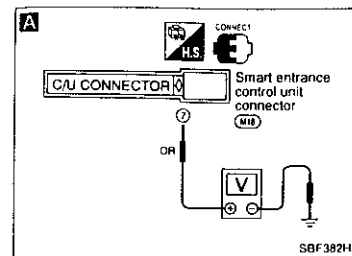

Trouble Diagnoses (Cont'd)

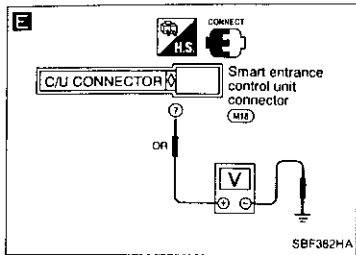

**E** Push lock button of remote controller and check voltage across control unit terminal ⑦ and GND.  
**is voltage approx. 0V?**

No → Replace smart entrance control unit.

Yes →

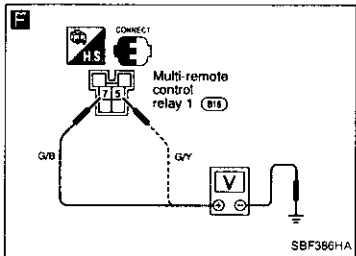

**F** Push lock button of remote controller and check voltage across multi-remote control relay 1 terminal ③ and GND.  
**Does battery voltage exist?**

Yes → Repair hazard switch circuit harness.

No →

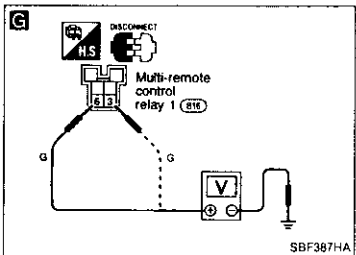

**G** Disconnect connector from multi-remote control relay 1. Check voltage across multi-remote control relay terminal ③ and GND, ⑥ and GND.  
**Does battery voltage exist?**

No → Repair power supply harness.

Yes → Replace multi-remote control relay 1.

DIAGNOSTIC PROCEDURE 5

**SYMPTOM:** Interior lamp does not turn on for 30 seconds when pressing unlock button of remote controller. Everything else functions.

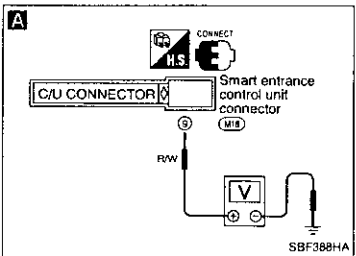

**A** CHECK INTERIOR LAMP CIRCUIT. When interior lamp switch is "DOOR" position, check voltage across control unit terminal ⑨ and GND.  
**Does battery voltage exist?**

No → Repair harness between control unit connector and interior lamp connector.

Yes →

**A** Push unlock button of remote controller and check voltage across control unit terminal ⑨ and GND.  
**Is voltage approx. 0V?**

No → Replace smart entrance control unit.

Yes → Check system again

Replacing Remote Controller or Control Unit

If the remote controller or the control unit needs to be replaced or if an additional remote controller needs to be set, enter the identity (ID) code manually.

ID Code Entry Procedure

To enter the ID code, follow this procedure.

"Setting mode":

Three steps must be followed to establish the "setting mode".

- (1) Close and lock all doors.
- (2) Insert and remove the key from the ignition more than six times within 10 seconds. (The hazard warning lamp will then flash twice.)

- At this time, the original ID codes are eliminated.

ID code entry:

- (3) Turn ignition key to "ACC" position.
- (4) Push lock button on the new remote controller once (for example, if door is locked using the remote controller during this ID code entry enable state, a new ID code can be entered).

- At this time, the new ID code is entered. (The hazard warning lamp will then flash twice.)

- (5) If you need to enter additional remote controllers (including the original), release the driver's door lock, then lock again with door lock knob.

- (6) Push lock button on the new additional remote controller once.
- (7) This ID code entry enable state and setting mode remain until the driver's door is opened.

NOTE

- If the same ID code that existing in the memory is input, the entry is canceled, and no ID code will be entered.

- Entry of maximum four ID codes is allowed and any attempt to enter more will be ignored.

- Any ID codes entered after termination of the "setting" mode will not be accepted. Additionally remote control signals will be inhibited when an ID code has not been entered during the "setting" mode.

## THEFT WARNING SYSTEM

### System Description (Cont'd)

#### OPERATION

Put using the key

the door.

When activated, if the smart entrance control unit receives a ground (described under THEFT WARNING SYSTEM ACTIVATION), the system is triggered. Also, when a door key tamper signal is received at the smart entrance control unit, the system is triggered. The hazard warning lamps flash and the horns sound intermittently.

When the door key cylinder switch is tampered with, smart entrance control unit terminal ②

receives a ground from the door key cylinder switch.

When the door key cylinder switch is tampered with, ground is supplied to smart entrance control unit terminal ②.

When the smart entrance control unit receives a ground to the inhibitor switch (A/T models) or starter motor (M/T models), the system is triggered. The engine will not crank and the engine will not start.

When the smart entrance control unit receives a ground in the fusible link and fuse box terminals ① and ⑥.

When the smart entrance control unit receives a ground in the fusible link and fuse box terminal ③.

When the smart entrance control unit receives a ground in the fuse block terminals ①, ③ and ⑥.

When the smart entrance control unit receives a ground, ground is supplied intermittently to smart entrance control unit terminal ②.

When the smart entrance control unit receives a ground in terminal ②.

The horns sound intermittently.

The system is triggered for approximately 30 seconds but will reactivate if the vehicle is

#### ACTIVATION

When a door or the trunk lid must be unlocked with the key or remote

transmitter, ground is supplied to smart entrance control unit terminal ④.

When the door key cylinder switch

is tampered with, ground is supplied to smart entrance control unit terminal ②.

When the door key cylinder switch is tampered with, ground is supplied to smart entrance control unit terminal ②.

When the door key cylinder switch is tampered with, ground is supplied to smart entrance control unit terminal ②.

When the door key cylinder switch is tampered with, ground is supplied to smart entrance control unit terminal ②.

When the door key cylinder switch is tampered with, ground is supplied to smart entrance control unit terminal ②.

When the door key cylinder switch is tampered with, ground is supplied to smart entrance control unit terminal ②.

When the door key cylinder switch is tampered with, ground is supplied to smart entrance control unit terminal ②.

When the door key cylinder switch is tampered with, ground is supplied to smart entrance control unit terminal ②.

When the door key cylinder switch is tampered with, ground is supplied to smart entrance control unit terminal ②.

When the door key cylinder switch is tampered with, ground is supplied to smart entrance control unit terminal ②.

When the door key cylinder switch is tampered with, ground is supplied to smart entrance control unit terminal ②.

# THEFT WARNING SYSTEM

## Component Parts and Harness Connector Location

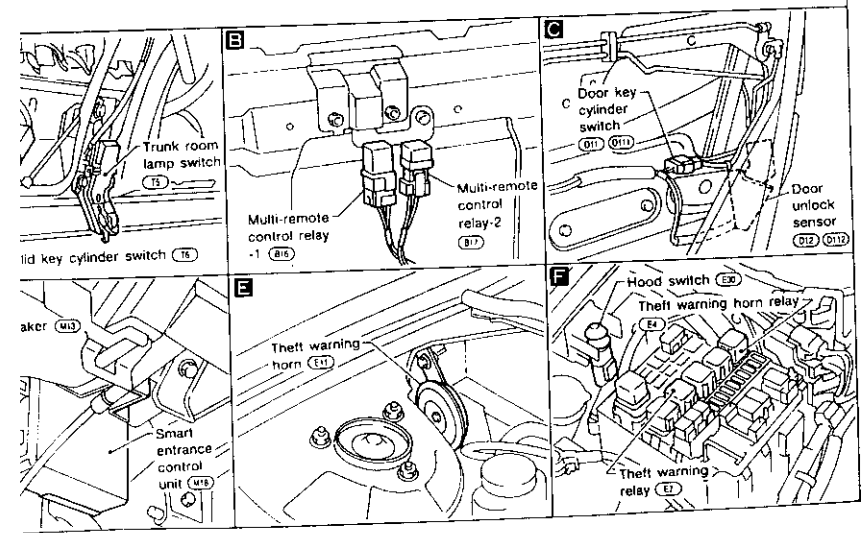
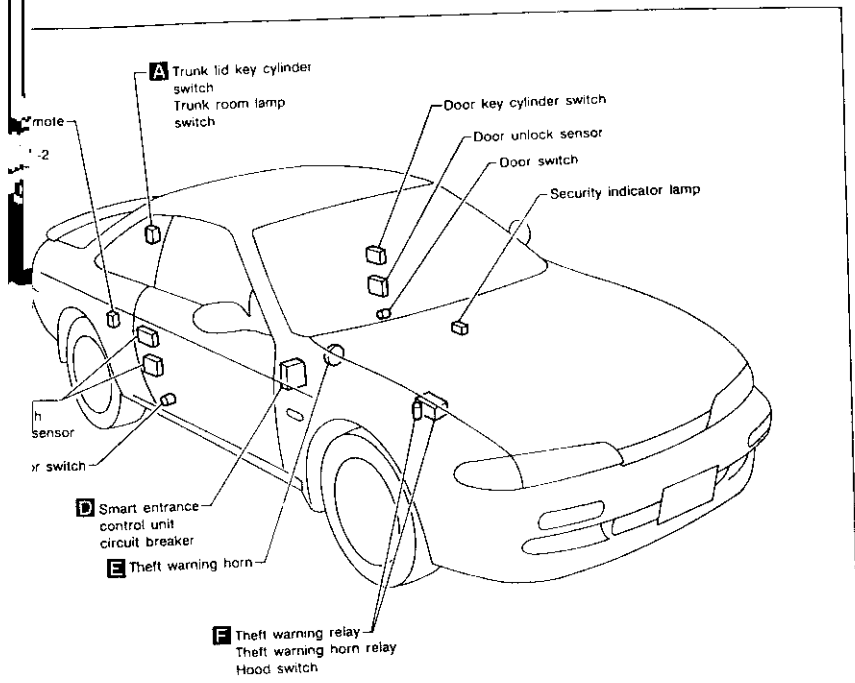

GI  
 MA  
 FM  
 LG  
 FC  
 TR  
 CI  
 MT  
 AT  
 PO  
 FA  
 BA  
 BR  
 ST  
 RS  
 BT  
 HA  
 EL  
 DX

SEL856T

# THEFT WARNING SYSTEM

## Wiring Diagram — THEFT —

EL-THEFT-01

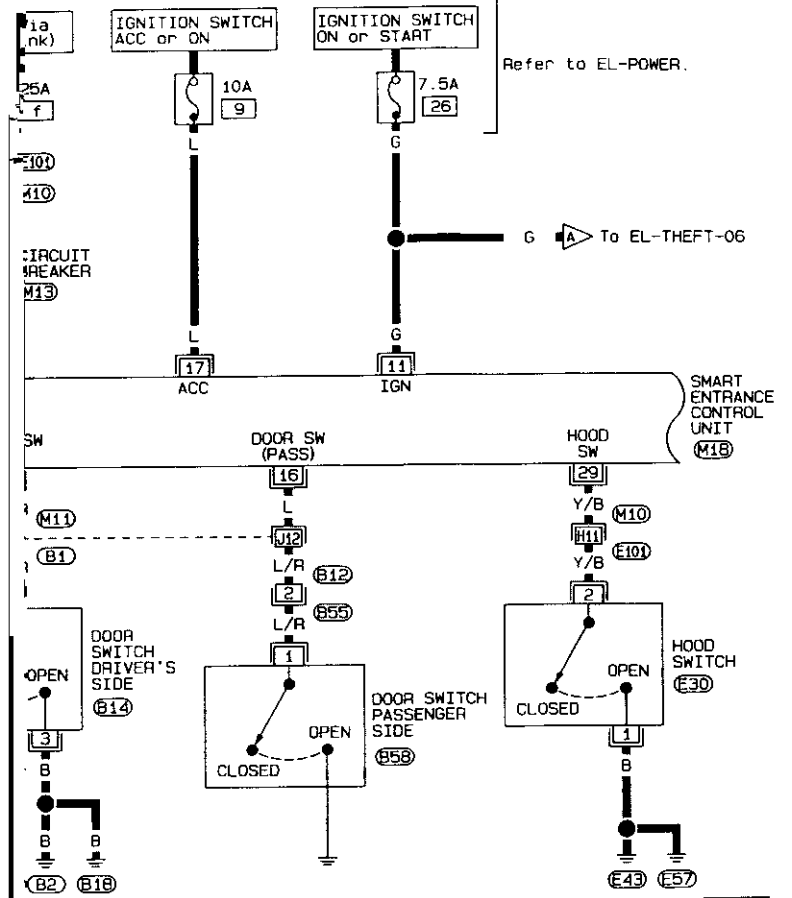

Refer to EL-POWER.

To EL-THEFT-06

Refer to last page (Foldout page).

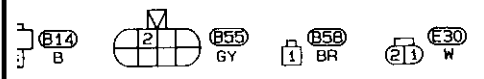

- M10, E101
- M11, B1
- M18

EL

10X

# THEFT WARNING SYSTEM

Wiring Diagram — THEFT — (Cont'd)

EL-THEFT-02

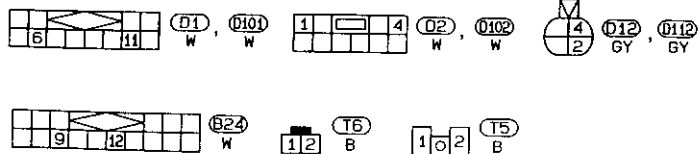
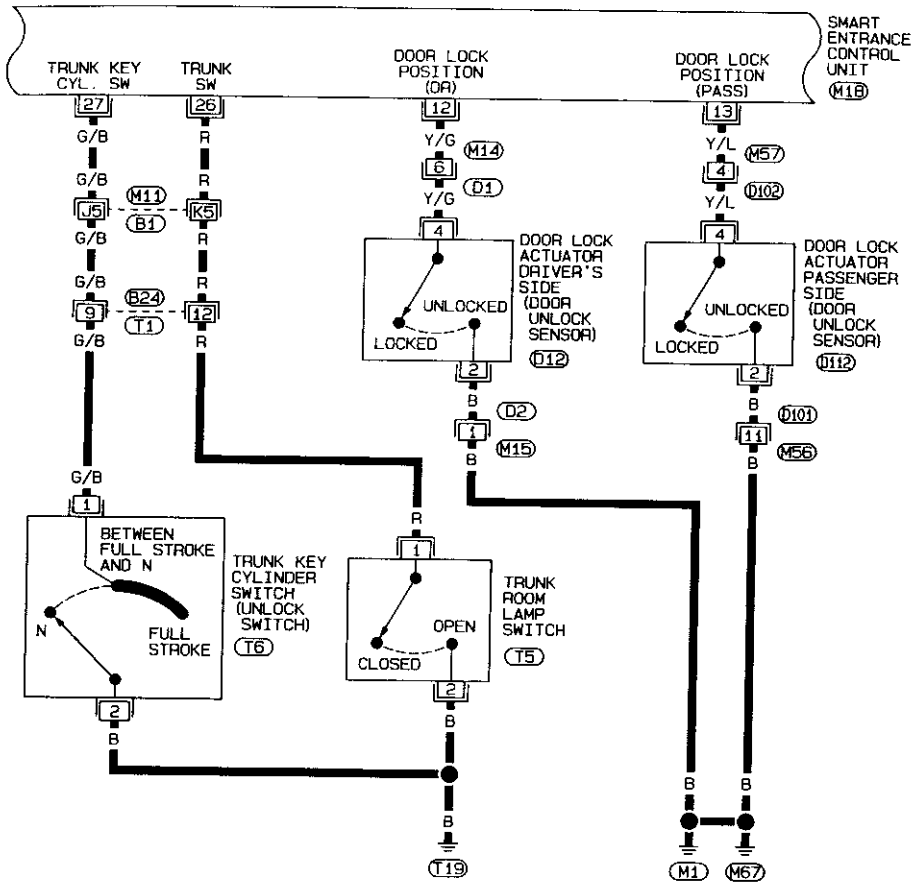

Refer to last page (Foldout page).

M11, B1  
M18

# THEFT WARNING SYSTEM

Wiring Diagram — THEFT — (Cont'd)

EL-THEFT-03

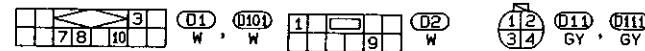
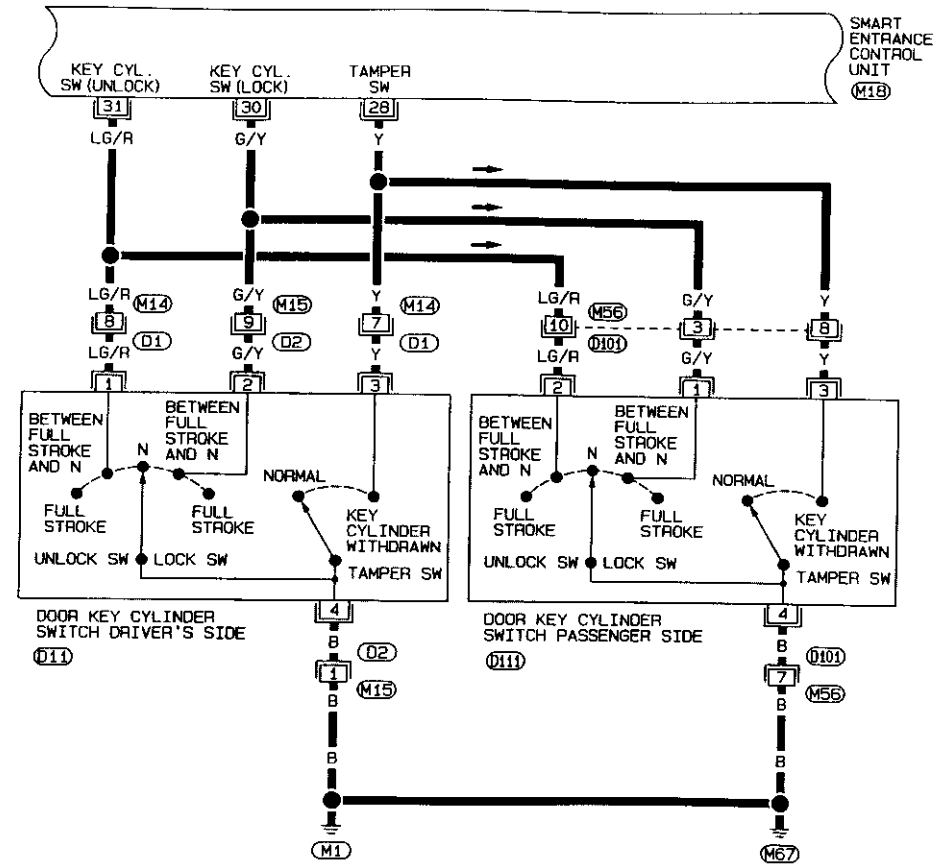

Refer to last page (Foldout page).

M18

**THEFT WARNING SYSTEM**  
Wiring Diagram — THEFT — (Cont'd)

EL-THEFT-04

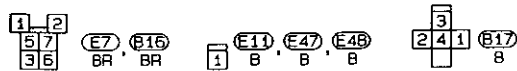
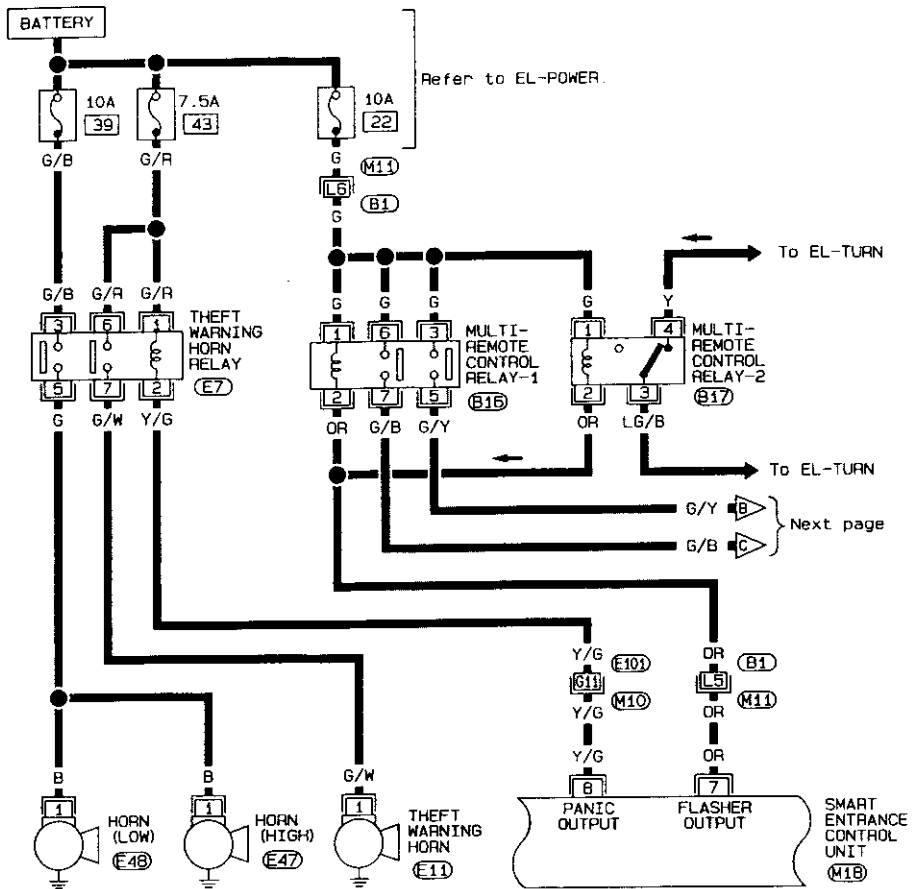

EL-226

SEL779T

**THEFT WARNING SYSTEM**  
Wiring Diagram — THEFT — (Cont'd)

EL-THEFT-05

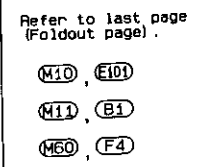
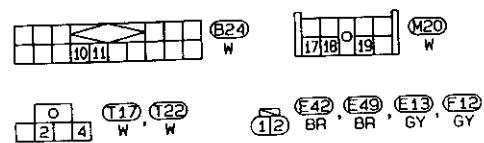
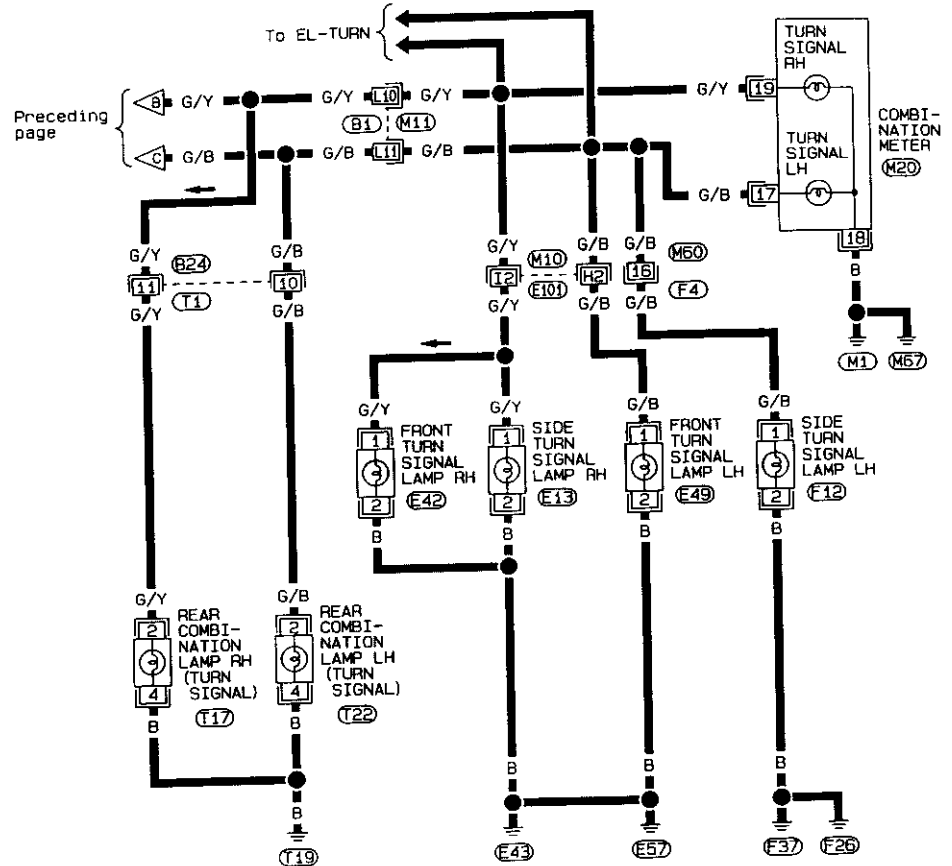

EL-227

SEL779T



# THEFT WARNING SYSTEM

## Input/Output Operation Signal

### SMART ENTRANCE CONTROL UNIT

Terminal No.	Connections	Operated condition	Voltage (V) (Approximate values)
1	Power source (C/B)	—	12V
7	Multi-remote control relays 1 and 2	When panic alarm is operated.	12V → 1V or less
8	Theft warning horn relay	When panic alarm is operated.	12V → 1V or less
10	Ground	—	—
11	Ignition switch (ON)	"ON" or "START" position	12V
12	Driver door unlock sensor	Driver door: Locked → Unlocked	12V → 4.5V or less
13	Passenger door unlock sensor	Passenger door: Locked → Unlocked	12V → 4.5V or less
15	Driver door switch	OFF (Closed) → ON (Open)	12V → 4.5V or less
16	Passenger door switch	OFF (Closed) → ON (Open)	12V → 1.5V or less
17	Ignition switch (ACC)	"ACC" or "ON" position	12V
26	Trunk room lamp switch	ON (Open) → OFF (Closed)	0V → 12V
27	Trunk key cylinder switch	OFF (Neutral) → ON (Unlocked)	4.5V or more → 0V
28	Door key cylinders tamper switch	OFF → ON	4.5V or more → 0V
29	Hood switch	ON (Open) → OFF (Closed)	0V → 4.5V or more
30	Door key cylinder lock switch	OFF (Neutral) → ON (Locked)	4.5V or more → 0V
31	Door key cylinder unlock switch	OFF (Neutral) → ON (Unlocked)	4.5V or more → 0V
32	Theft warning relay (Starter cut)	OFF → ON	12V → 0V
33	Security indicator	Goes off → Illuminates	12V → 0V

T'd)

THEFT-06

R.

Models  
Models  
R, (M) B/W

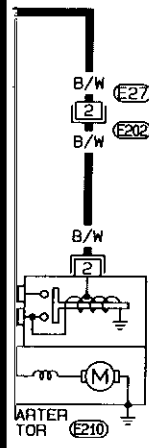

Refer to last page (out page).

(10), (E101)

(18)



## THEFT WARNING SYSTEM

### Trouble Diagnoses (Cont'd)

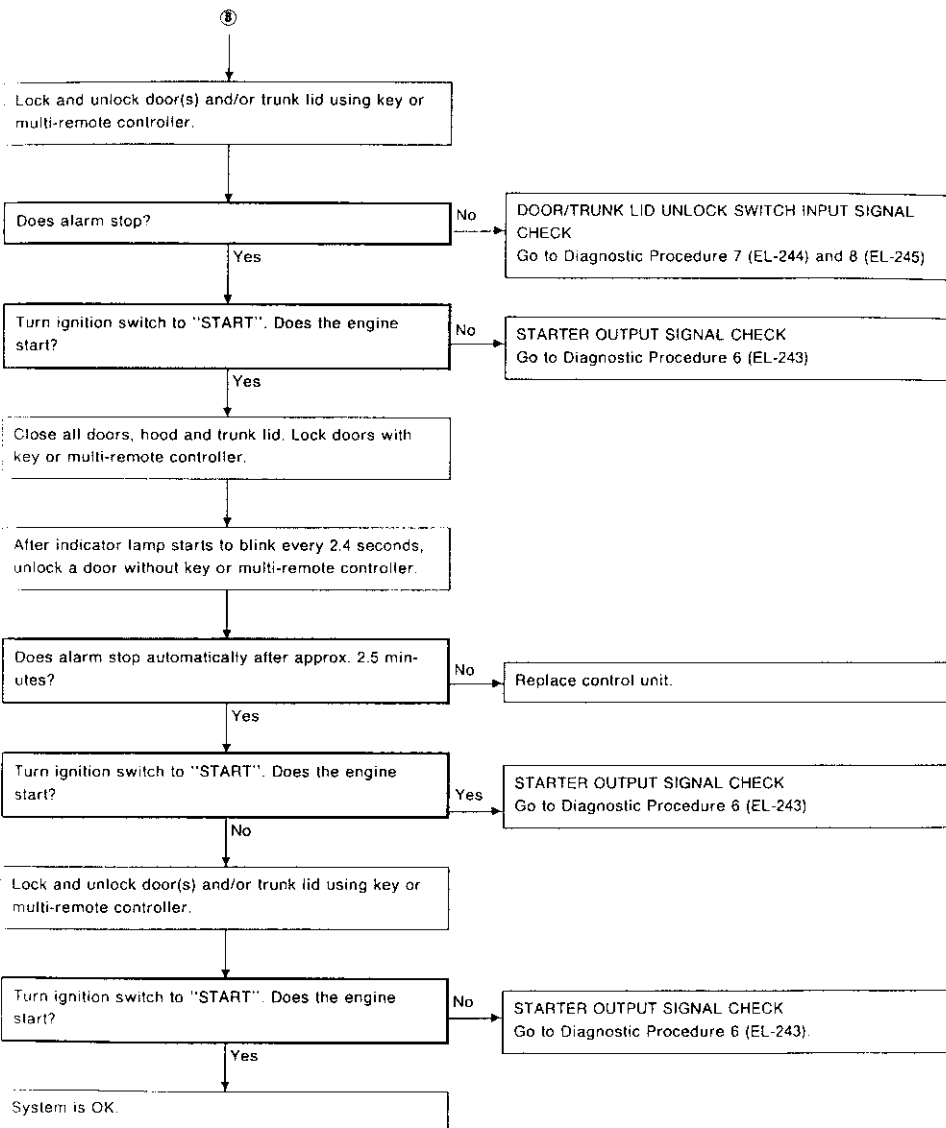

## THEFT WARNING SYSTEM

### Trouble Diagnoses (Cont'd)

#### POWER SUPPLY AND GROUND CIRCUIT CHECK

##### Main power supply circuit check

Terminals	Ignition switch position		
	OFF	ACC	ON
① - ⑩	Battery voltage	Battery voltage	Battery voltage

##### Power supply circuit check for system cancel

Terminals	Ignition switch position		
	OFF	ACC	ON
⑩ - ⑪	0V	Battery voltage	Battery voltage

##### Ground circuit check

Terminals	Continuity
⑩ - Ground	Yes

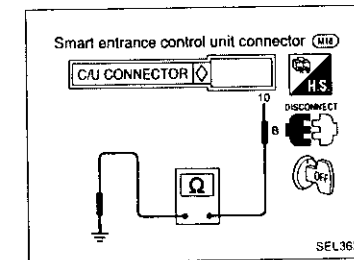
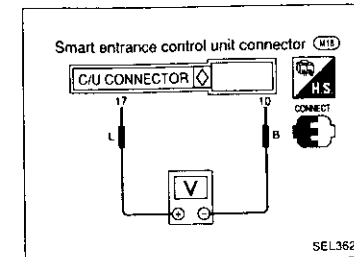
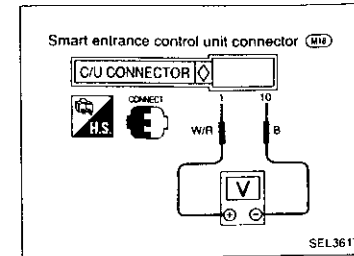

## THEFT WARNING SYSTEM

### Trouble Diagnoses (Cont'd)

#### DIAGNOSTIC PROCEDURE 1

**SYMPTOM:** ● Indicator lamp does not blink or  
● Indicator lamp remains blinking every second.  
**Diagnostic procedure 1-(1)**

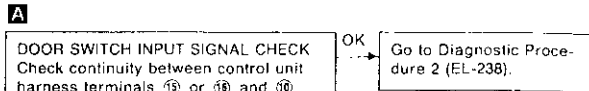
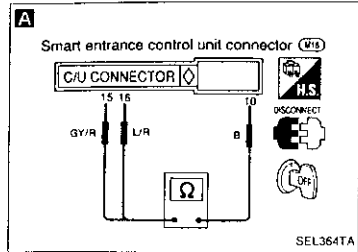

Condition	Continuity between 15 and 10
Driver side door is closed.	No
Driver side door is opened.	Yes

Condition	Continuity between 16 and 10
Passenger side door is closed.	No
Passenger side door is opened.	Yes

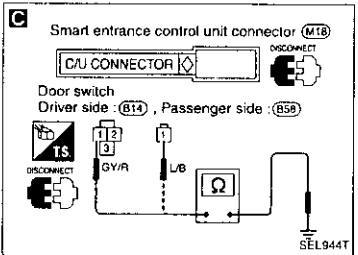
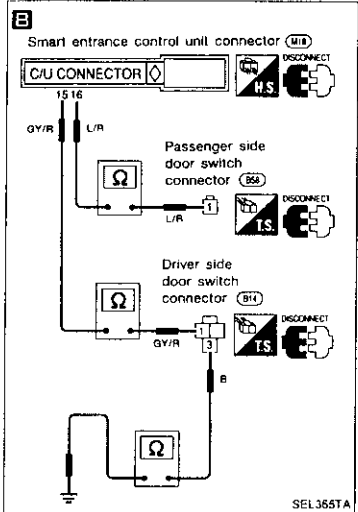
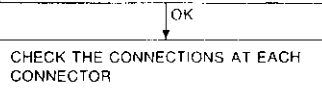
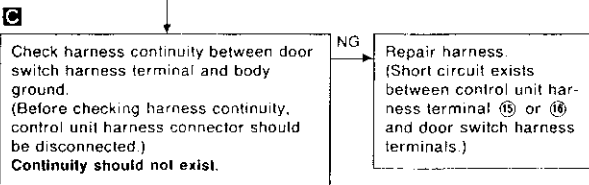
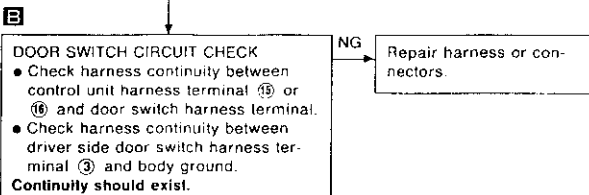
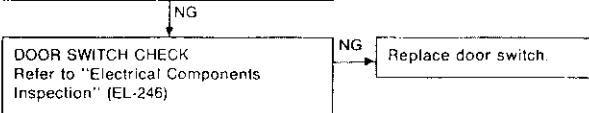

## THEFT WARNING SYSTEM

### Trouble Diagnoses (Cont'd)

#### Diagnostic procedure 1-(2)

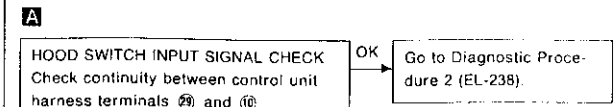
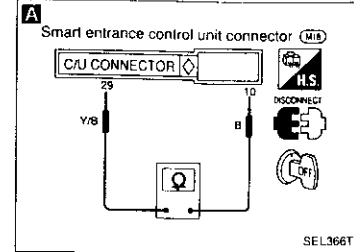

Condition	Continuity
Hood is open.	Yes
Hood is closed.	No

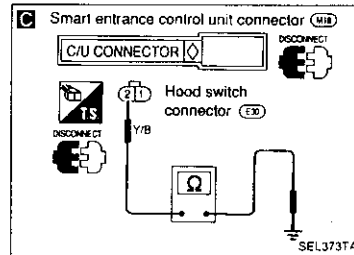
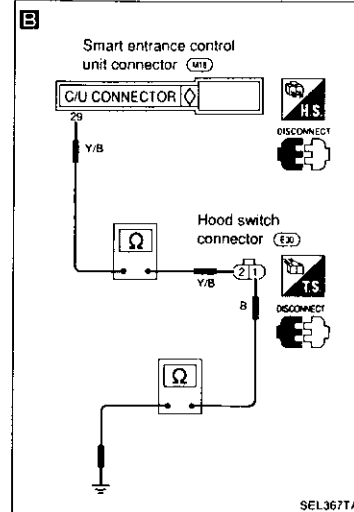
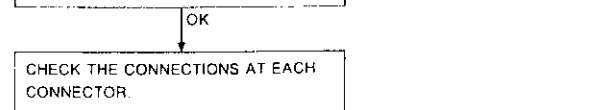
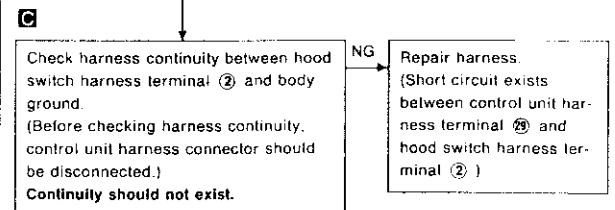
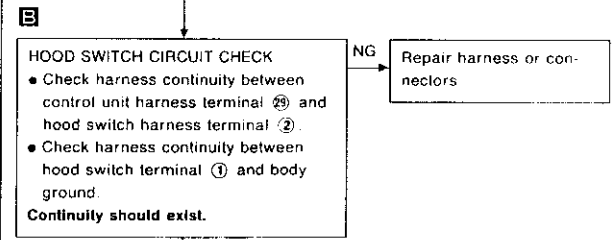
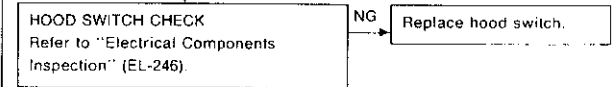
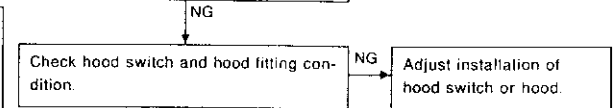

## THEFT WARNING SYSTEM

### Trouble Diagnoses (Cont'd)

#### Diagnostic procedure 1-(3)

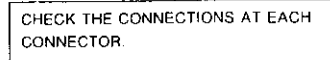
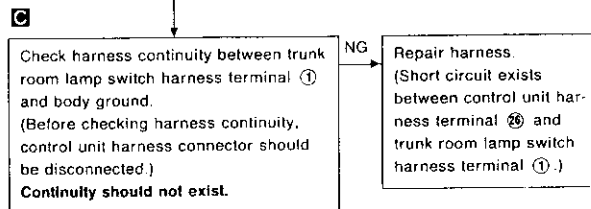
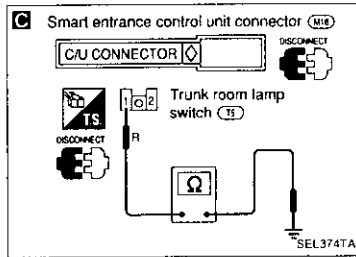
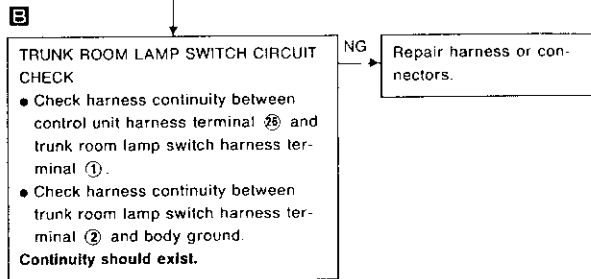
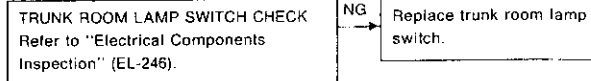
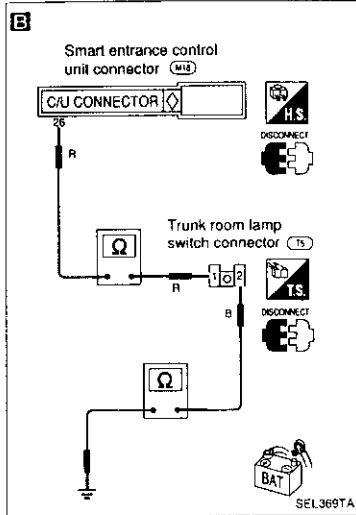
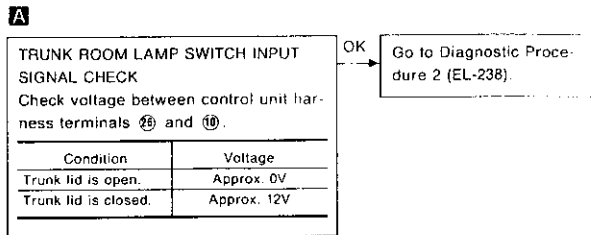
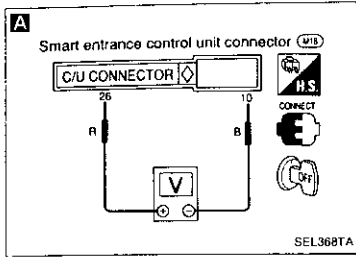

## THEFT WARNING SYSTEM

### Trouble Diagnoses (Cont'd)

#### Diagnostic procedure 1-(4)

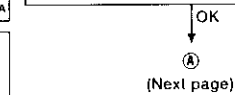
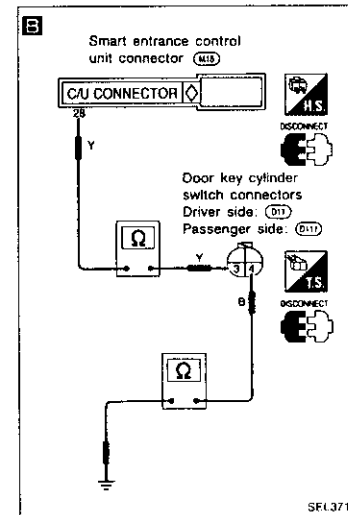
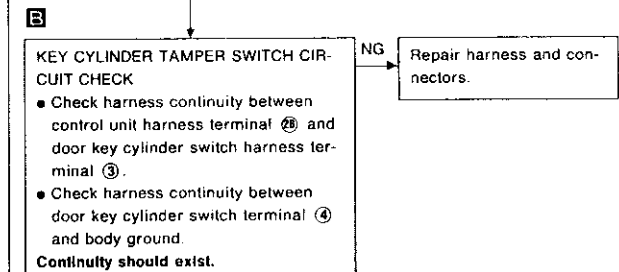
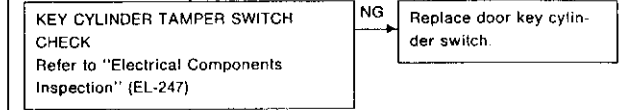
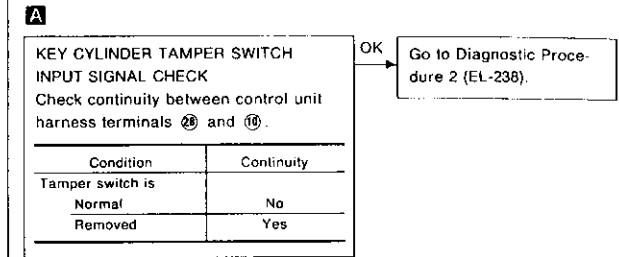
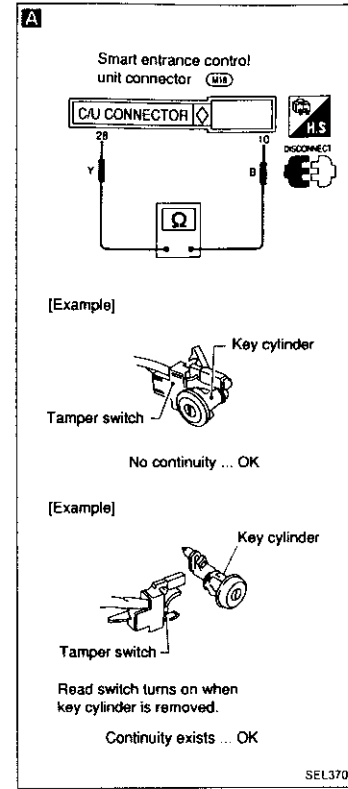

# THEFT WARNING SYSTEM

## Trouble Diagnoses (Cont'd) DIAGNOSTIC PROCEDURE 3

SYMPTOM: Indicator lamp does not come on.

d) NG Repair harness. (Short circuit exists between control unit harness terminal ② and door key cylinder switch terminal ③.)

s not blink or ains "ON". OK Replace control unit.

NG Replace indicator lamp.

NG Repair harness or connectors.

NG Repair harness or connectors.

NG Repair harness. (Short circuit exists between control unit harness terminal ② and indicator lamp harness terminal ①.)

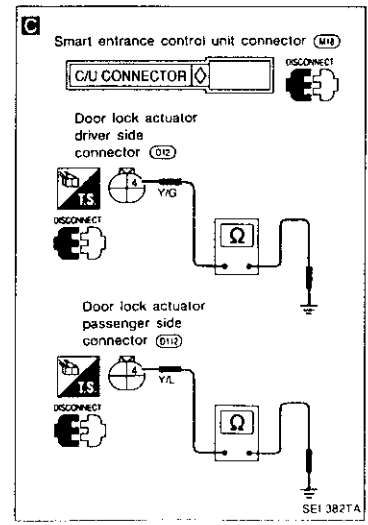
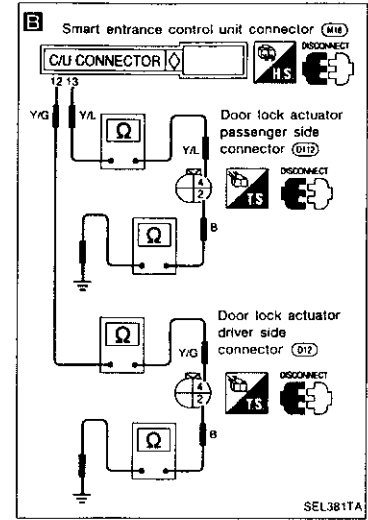
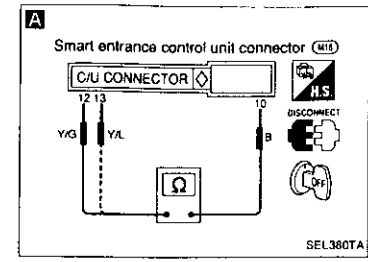

**A** DOOR UNLOCK SENSOR INPUT SIGNAL CHECK  
Check continuity between control unit harness terminals ⑫ or ⑬ and ⑩.

Condition	Continuity between ⑫ and ⑩
Driver side door is locked.	No
Driver side door is unlocked.	Yes

Condition	Continuity between ⑬ and ⑩
Passenger side door is locked.	No
Passenger side door is unlocked.	Yes

OK Go to Diagnostic Procedure 2 (EL-238).  
OK Replace control unit.

NG DOOR UNLOCK SENSOR CHECK Refer to "Electrical Components Inspection" (EL-247). NG Replace door lock actuator.

**B** DOOR UNLOCK SENSOR CIRCUIT CHECK  
• Check harness continuity between control unit harness terminal ⑫ or ⑬ and door actuator terminal ④  
• Check harness continuity between door lock actuator harness terminal ② and body ground. Continuity should exist. NG Repair harness or connectors.

**C** Check harness continuity between door lock actuator harness terminal ④ and body ground. (Before checking harness continuity, control unit harness connector should be disconnected.) Continuity should not exist. NG Repair harness. (Short circuit exists between control unit harness terminal ⑫ or ⑬ and door lock actuator harness terminal ④.)

OK CHECK THE CONNECTIONS AT EACH CONNECTOR

## THEFT WARNING SYSTEM

### Trouble Diagnoses (Cont'd)

#### DIAGNOSTIC PROCEDURE 4

SYMPTOM: Indicator lamp does not come on.

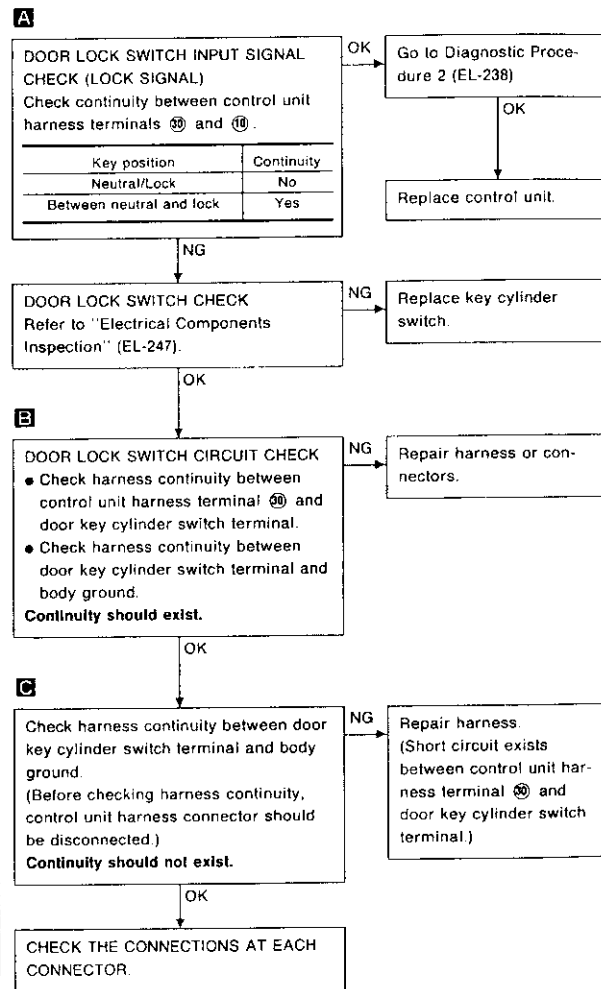

EL-240

## THEFT WARNING SYSTEM

### Trouble Diagnoses (Cont'd)

#### DIAGNOSTIC PROCEDURE 5

SYMPTOM: Alarm does not operate.

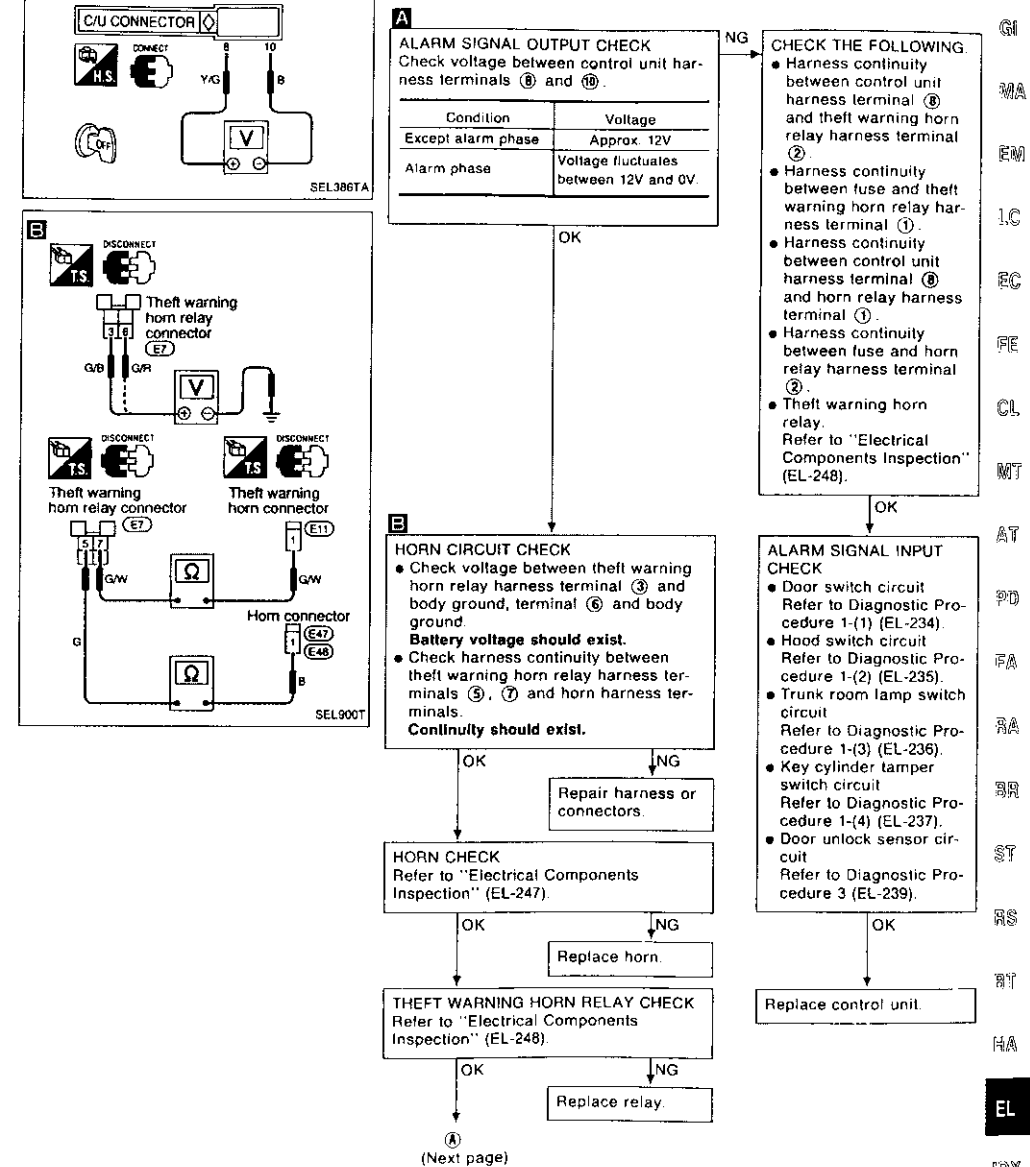

EL-241

## THEFT WARNING SYSTEM

### Trouble Diagnoses (Cont'd)

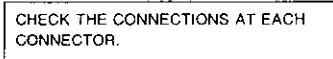
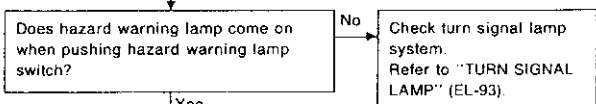
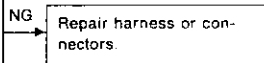
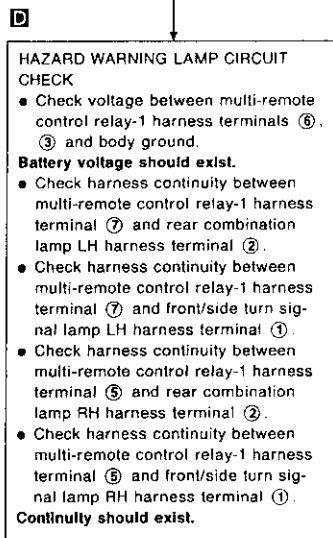
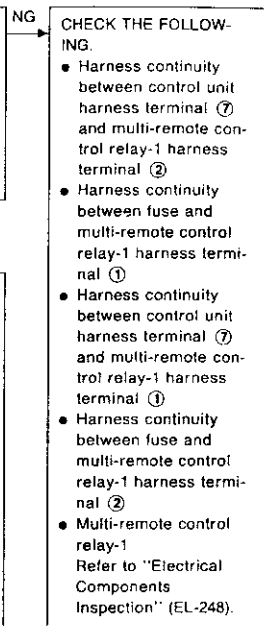
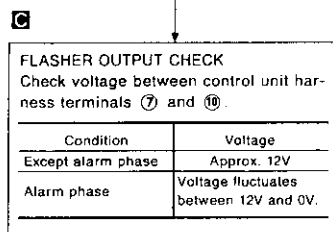
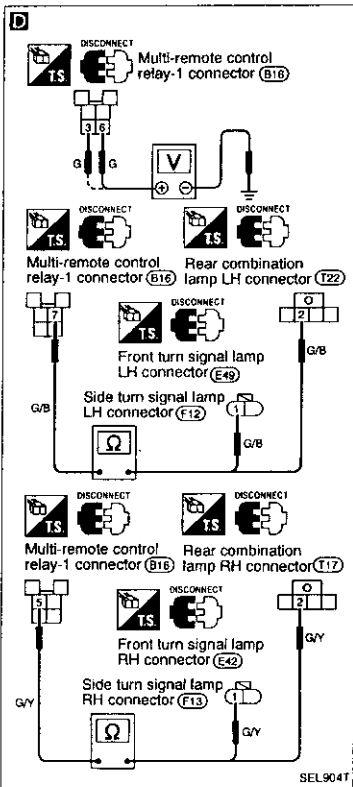
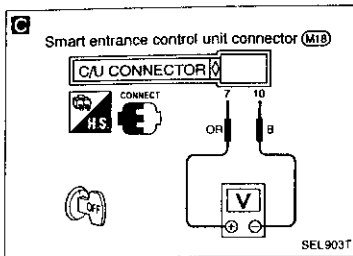

## THEFT WARNING SYSTEM

### Trouble Diagnoses (Cont'd)

#### DIAGNOSTIC PROCEDURE 6

**SYMPTOM:**

- **STARTER MOTOR** can be operated. (Starter killed phase) or
- **STARTER MOTOR** cannot be operated after the theft warning system is deactivated.

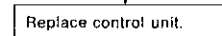
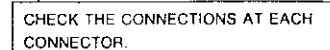
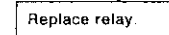
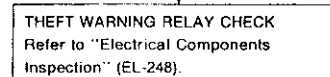
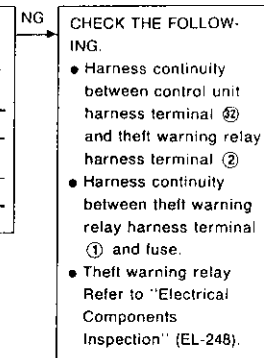
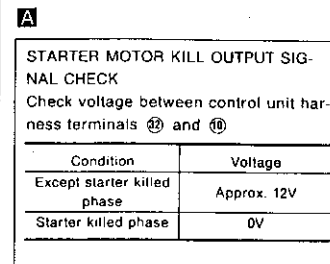
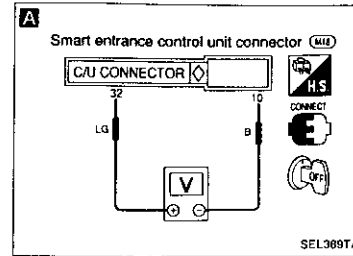



## THEFT WARNING SYSTEM

### Trouble Diagnoses (Cont'd) DIAGNOSTIC PROCEDURE 7

**SYMPTOM:** Alarm does not stop even if stop signal is given.

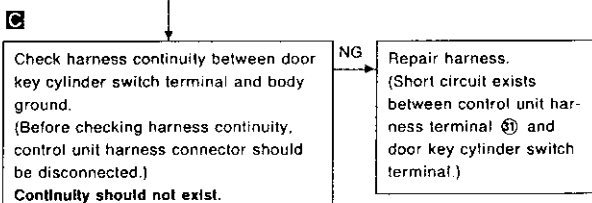
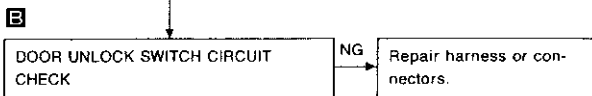
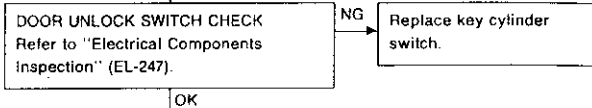
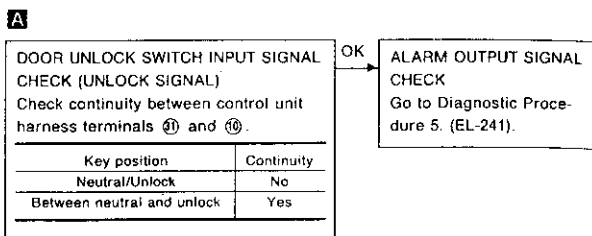
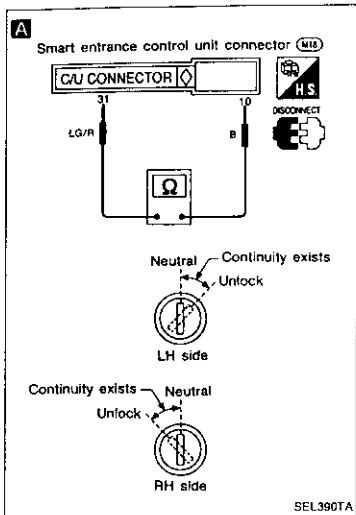

CHECK THE CONNECTIONS AT EACH CONNECTOR.

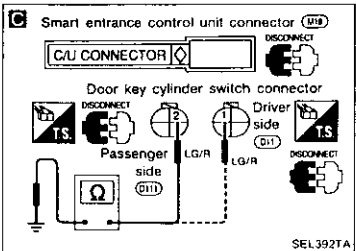
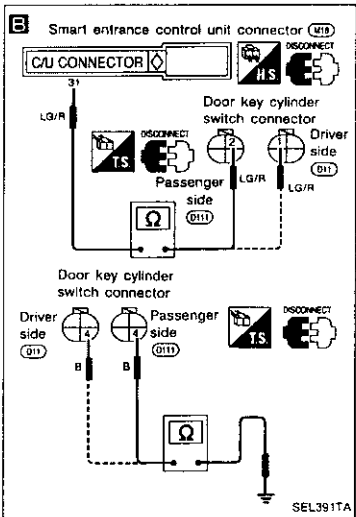

## THEFT WARNING SYSTEM

### Trouble Diagnoses (Cont'd) DIAGNOSTIC PROCEDURE 8

**SYMPTOM:** Alarm does not stop even if stop signal is given.

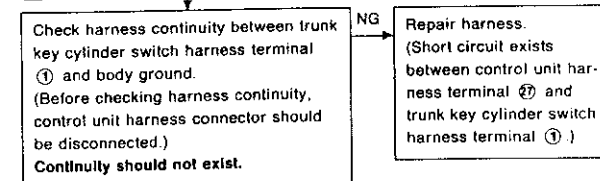
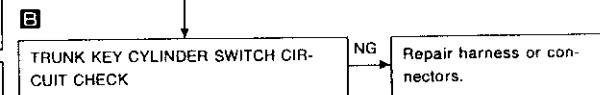
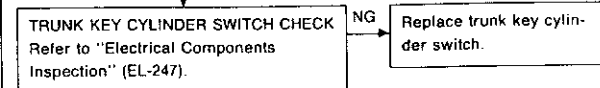
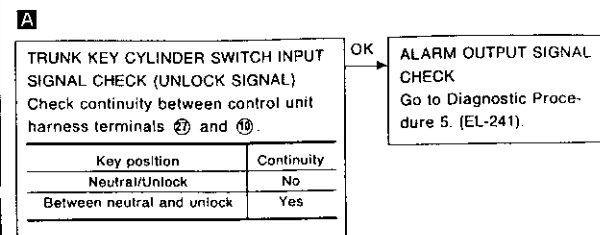
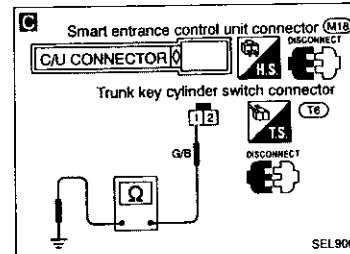
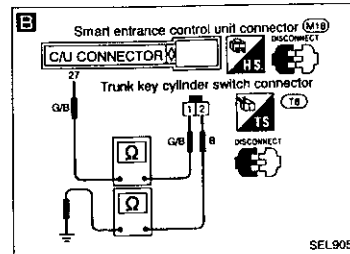
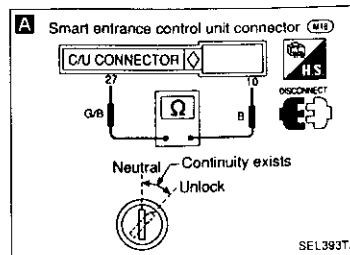

CHECK THE CONNECTIONS AT EACH CONNECTOR.

## THEFT WARNING SYSTEM

### Trouble Diagnoses (Cont'd) ELECTRICAL COMPONENTS INSPECTION

#### Door switches

Check continuity between terminals when door switch is pushed and released.

Terminal No.	Condition	Continuity
Driver side: ① - ③	Door switch is pushed.	No
Passenger side: ① - body ground	Door switch is released.	Yes

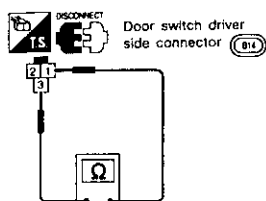

SEL396TA

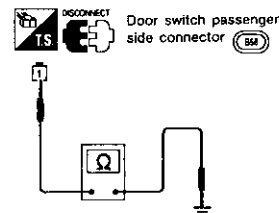

#### Hood switch

Check continuity between terminals when hood switch is pushed and released.

Terminal No.	Condition	Continuity
① - ②	Hood switch is pushed.	No
	Hood switch is released.	Yes

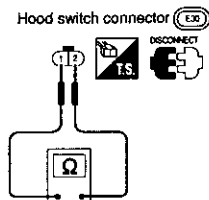

SEL397TA

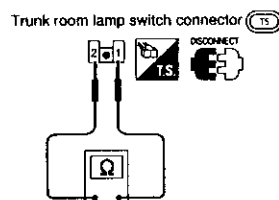

SEL398TA

#### Trunk room lamp switch

Check continuity between terminals when trunk lid is closed and opened.

Terminal No.	Condition	Continuity
① - ②	Trunk lid is closed.	No
	Trunk lid is opened.	Yes

## THEFT WARNING SYSTEM

### Trouble Diagnoses (Cont'd)

Key cylinder tamper switch, door lock switch and door unlock switch

#### • Door key cylinder switch

	Terminal No.	Condition	Continuity
Tamper switch	③ - ④	Key cylinder is installed.	No
		Key cylinder is removed.	Yes
Door lock switch	Driver side: ② - ④	Key position is neutral or lock.	No
	Passenger side: ① - ④	Key position is between neutral and lock.	Yes
Door unlock switch	Driver side: ① - ④	Key position is neutral or unlock.	No
	Passenger side: ② - ④	Key position is between neutral and unlock.	Yes

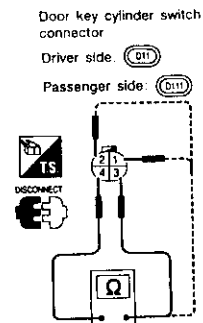

- ① Door lock switch terminal (Passenger side)
- ② Door unlock switch terminal (Driver side)
- ③ Door lock switch terminal (Passenger side)
- ④ Door lock switch terminal (Driver side)
- ⑤ Key cylinder tamper switch terminal
- ⑥ Ground terminal

SEL399TA

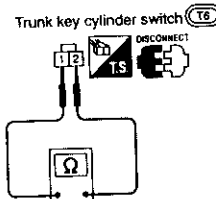

SEL907T

#### • Trunk key cylinder switch (unlock switch)

Terminal No.	Condition	Continuity
① - ②	Key position is neutral.	No
	Key position is unlock.	Yes

#### • Door lock actuator (Door unlock sensor)

Terminal No.	Condition	Continuity
④ - ②	Door is locked.	No
	Door is unlocked.	Yes

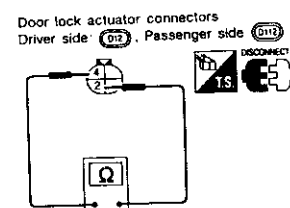

SEL401TA

Horn connectors  
E11, E17, E18

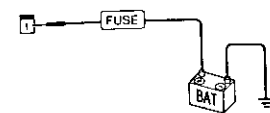

SEL402TA

#### Horns

Supply horn terminal with battery voltage and check horn operation.

GI  
MA  
EM  
LC  
EC  
FE  
CL  
MT  
AT  
PD  
FA  
RA  
BR  
ST  
RS  
BT  
HA  
EL  
DX

## THEFT WARNING SYSTEM

### Trouble Diagnoses (Cont'd)

#### Theft warning horn relay and multi-remote control relay-1

Check continuity between terminals ③ and ⑤, ⑥ and ⑦.

Condition	Continuity
12V direct current supply between terminals ① and ②	Yes
No current supply	No

#### Theft warning relay

Check continuity between terminals ③ and ④.

Condition	Continuity
12V direct current supply between terminals ① and ②	No
No current supply	Yes

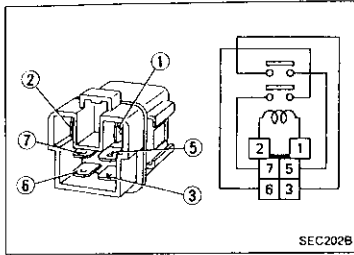

SEC202B

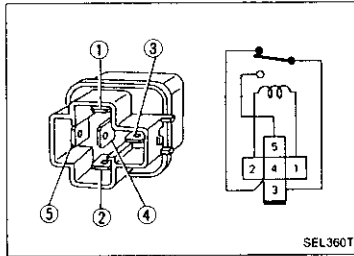

SEL360T

## LOCATION OF ELECTRICAL UNIT

### Engine Compartment

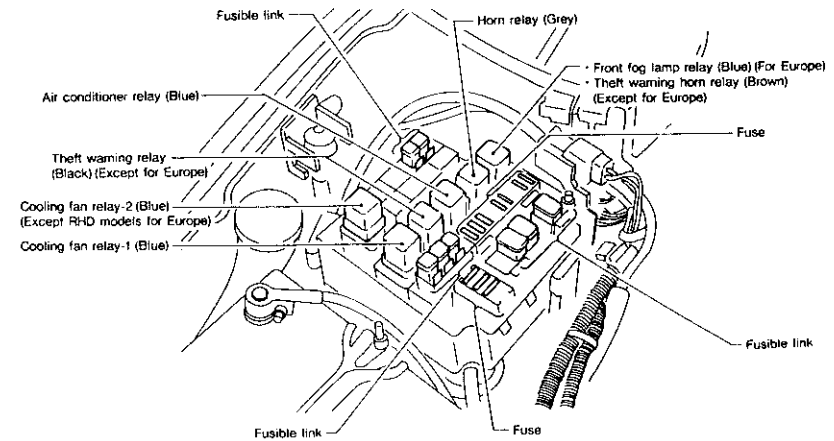
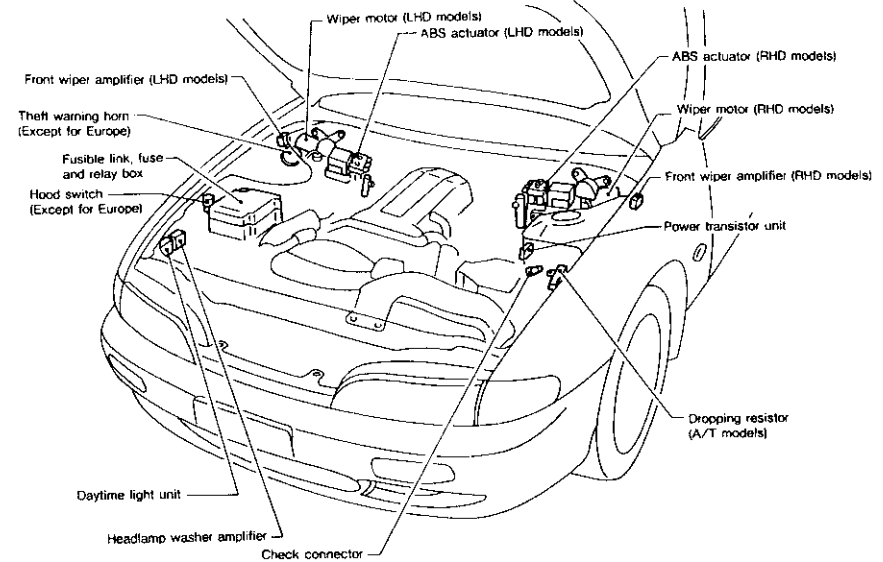

GI

MA

EM

LC

EC

PE

CL

MT

AT

PD

FA

BA

BR

ST

RS

BT

HA

EL

EX

LOCATION OF ELECTRICAL UNIT

Passenger Compartment

LHD MODELS

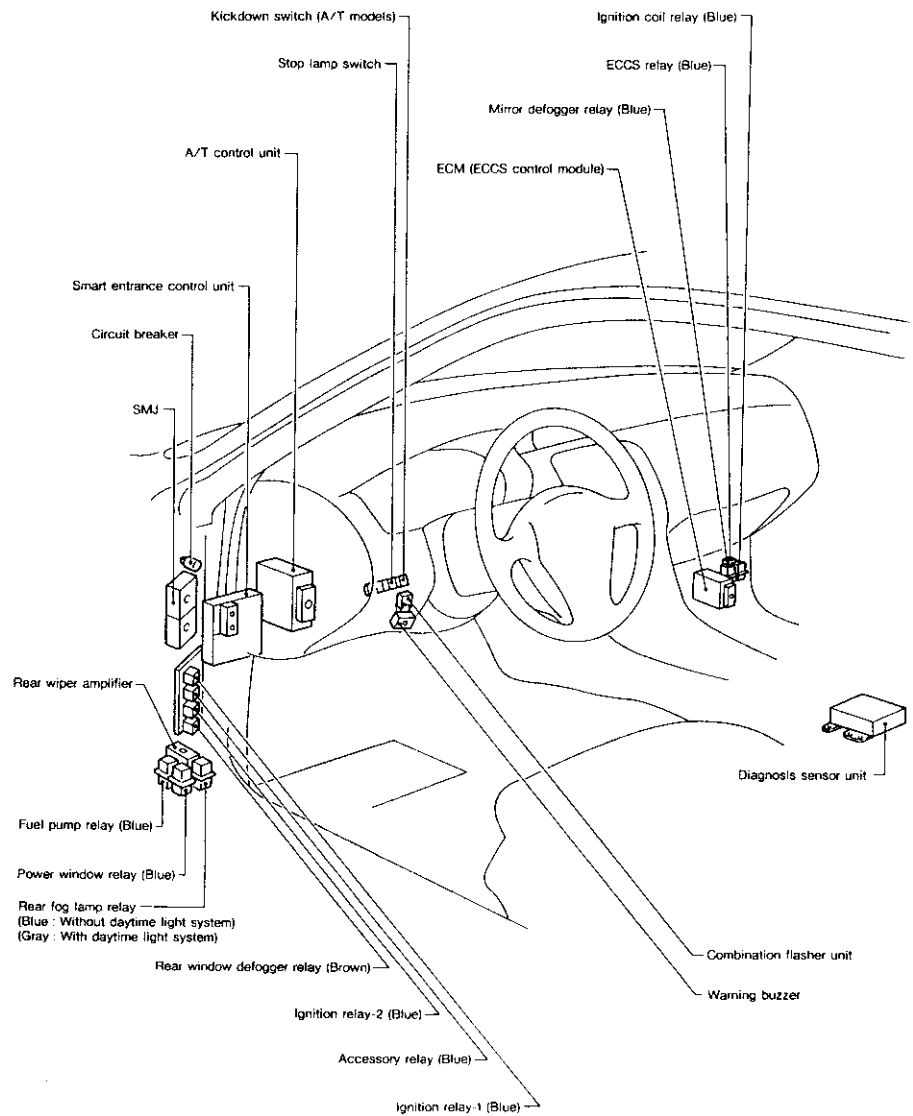

EL-250

SEL862T

LOCATION OF ELECTRICAL UNIT

Passenger Compartment (Cont'd)

RHD MODELS

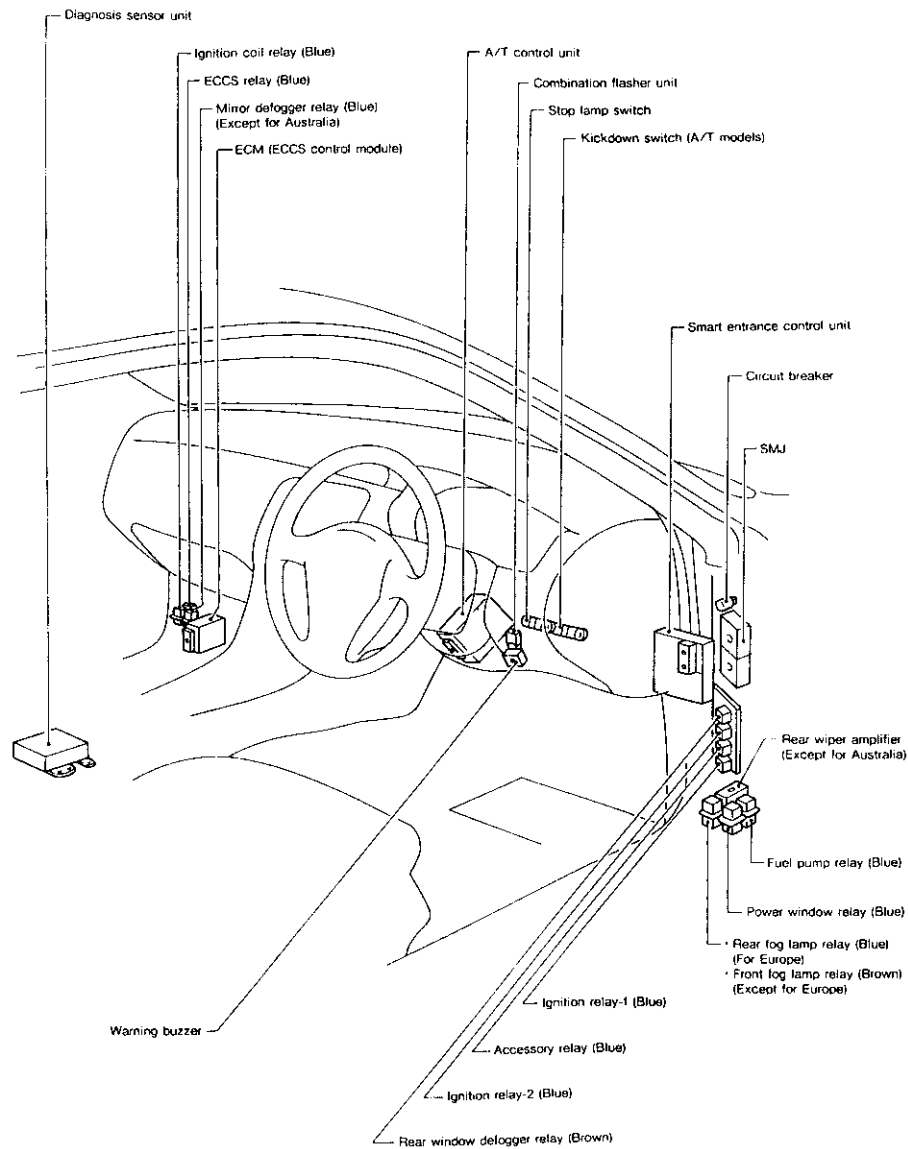

EL-251

SEL863T

CH  
 MA  
 EM  
 LC  
 EC  
 FE  
 CL  
 MT  
 AT  
 PD  
 SA  
 RA  
 BR  
 ST  
 RS  
 BT  
 HA  
 EL  
 BX

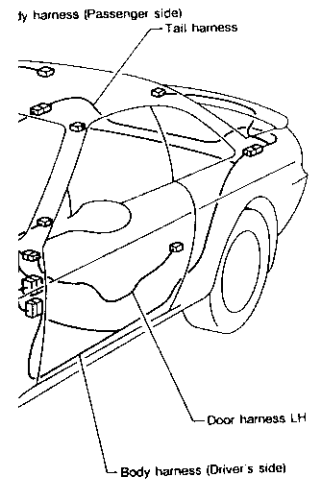

Air bag and pre-tensioner harness

SEL865T

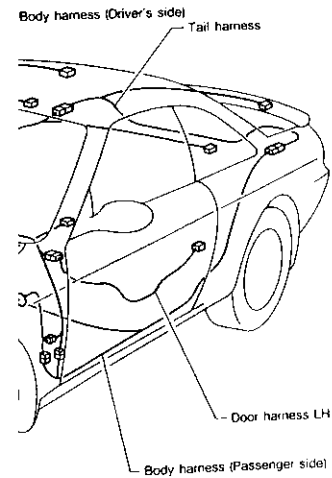

Air bag and pre-tensioner harness

SEL866T

GI  
MA  
EM  
LC  
EC  
FR  
CL  
WT  
AT  
PD  
FA  
RA  
BR  
ST  
RS  
BT  
HA  
EL  
DM

# HARNESS LAYOUT

## Main Harness

LHD MODELS

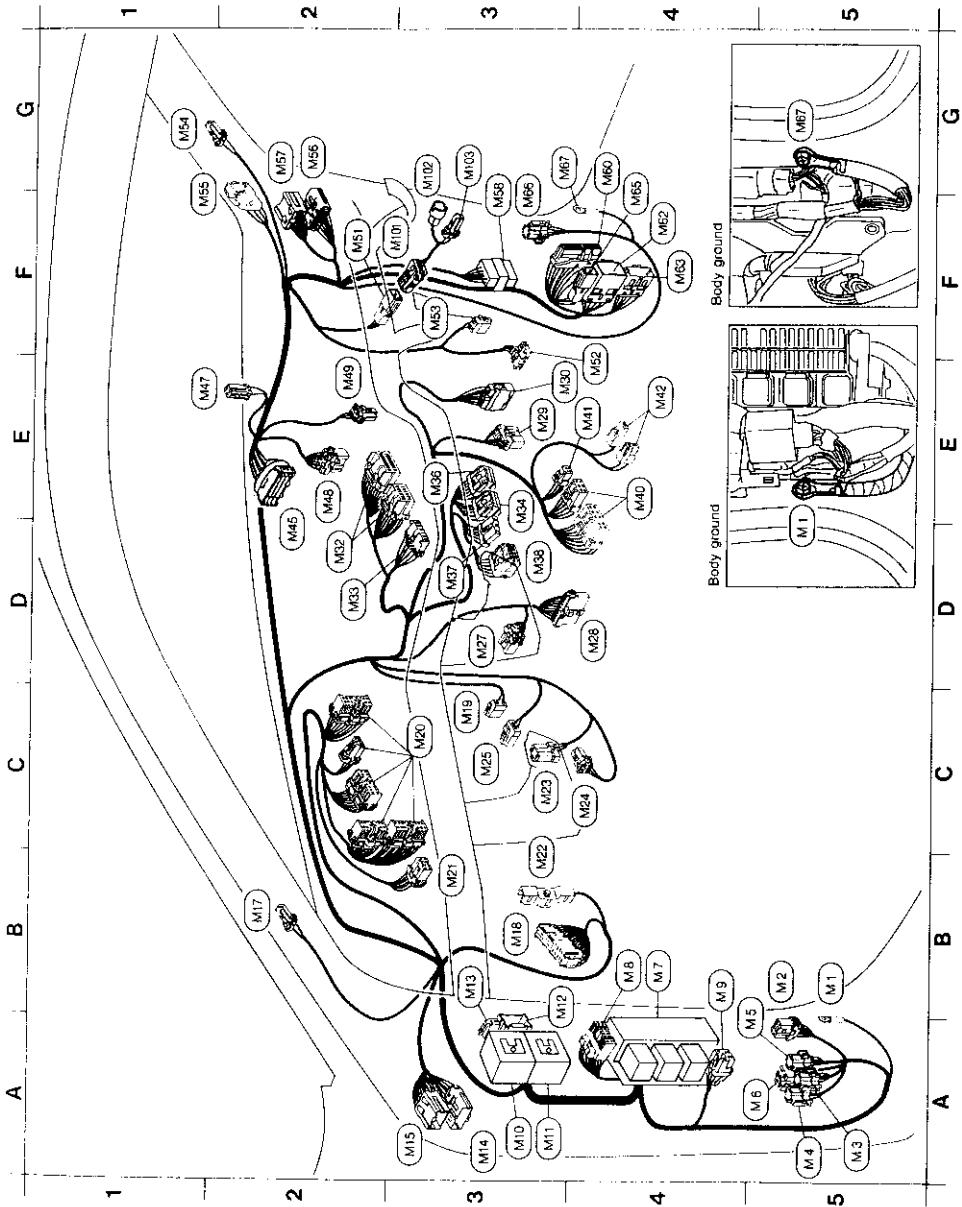

EL-254

# HARNESS LAYOUT

## Main Harness (Cont'd)

- B5 M1 : Body ground
- B5 M2 : Rear wiper amplifier
- A5 M3 : Fuel pump relay
- A5 M4 : Power window relay
- A5 M5 : Rear fog lamp relay (Models without daytime light system)
- A5 M6 : Rear fog lamp relay (Models with daytime light system)
- B4 M7 : Fuse block
- B4 M8 : Data link connector for CONSULT
- B4 M9 : Rear window defogger relay
- A3 M10 : To E30 (SMJ)
- A3 M11 : To E11 (SMJ)
- B3 M12 : To E09
- B3 M13 : Circuit breaker
- A3 M14 : To D1
- A3 M15 : To D2
- B2 M16 : Pillar speaker LH
- B3 M18 : Smart entrance control unit
- C3 M19 : Kickdown switch (A/T models)
- C3 M20 : Combination meter
- B3 M21 : Illumination control switch
- C3 M22 : A/T control unit (A/T models)
- C3 M23 : Combination flasher unit
- C4 M24 : Buzzer
- D3 M25 : Stop lamp switch
- D4 M26 : Air mix door motor
- E3 M28 : Mode door motor
- E3 M29 : Bi-level door motor
- E3 M30 : To Z5
- D2 M32 : Push control unit
- D2 M33 : Fan switch
- E3 M34 : Hazard switch
- E3 M36 : Headlamp washer switch
- D3 M37 : Rear window defogger switch
- D3 M38 : Rear fog lamp switch
- E4 M40 : Radio
- E4 M41 : Not used
- E4 M42 : Cigarette lighter
- D2 M45 : Joint connector
- E1 M47 : Not used
- E2 M48 : Intake door motor
- E2 M49 : Thermo control amplifier
- F2 M41 : To M40
- E4 M42 : Fan resistor
- F3 M43 : Blower motor
- G1 M44 : Pillar speaker RH
- F1 M45 : To R1
- G2 M49 : To D10
- G2 M47 : To D10
- F3 M48 : Joint connector
- G4 M49 : To F4
- F4 M42 : To F7 (A/T models)
- F4 M43 : To B51
- F4 M45 : To Z5 (M/T models)
- F3 M46 : Mirror defogger relay
- G3 M47 : Body ground
- F3 M40 : To M41
- G3 M42 : Glove box lamp
- G3 M43 : Glove box lamp switch

EL-255

## HARNESS LAYOUT Main Harness (Cont'd)

RHD MODELS

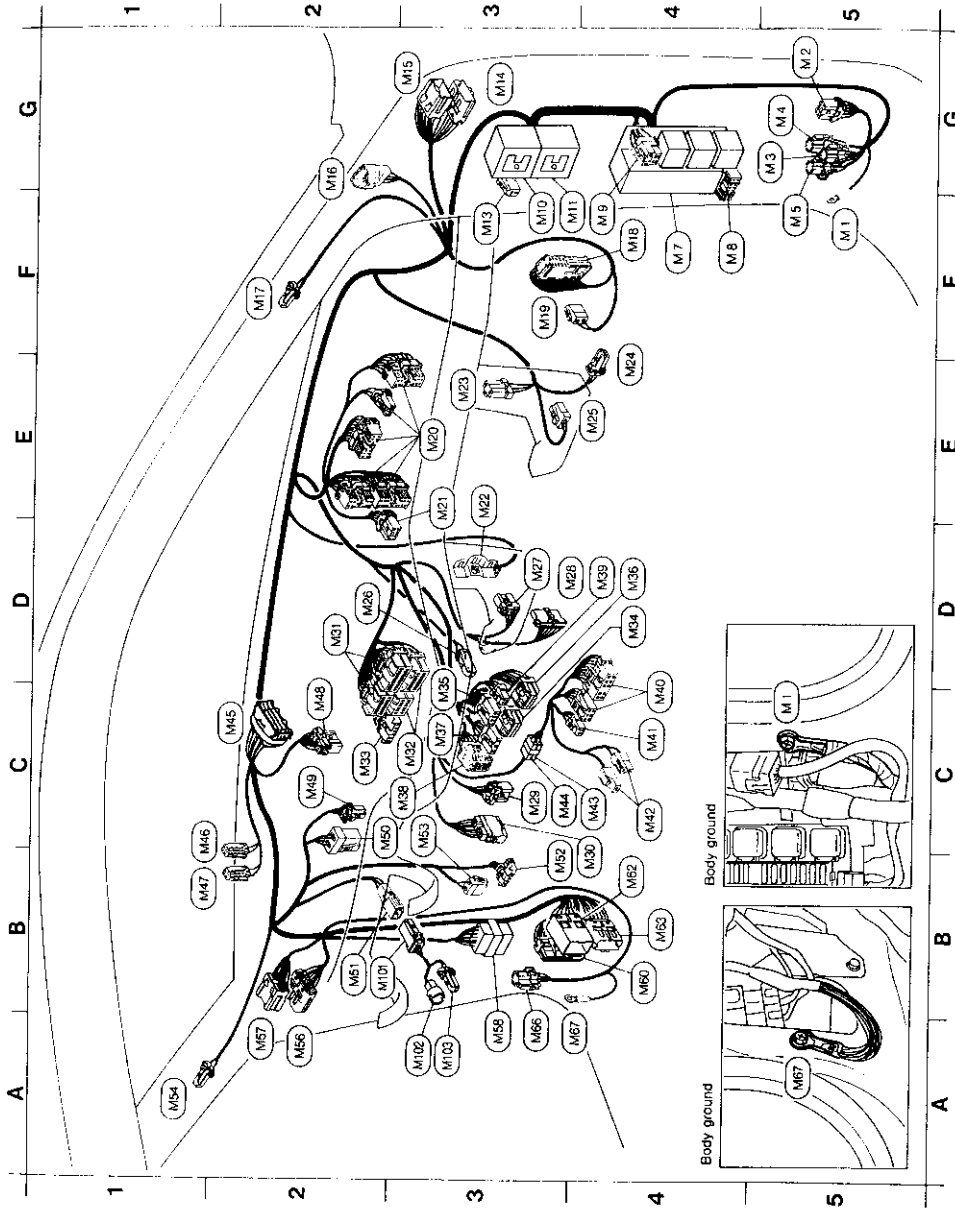

EL-256

## HARNESS LAYOUT Main Harness (Cont'd)

- F5 (M1) : Body ground
- G5 (M2) : Rear wiper amplifier (Except for Australia)
- G5 (M3) : Fuel pump relay
- G5 (M4) : Power window relay
- F5 (M5) : Rear fog lamp relay (For Europe)
- F4 (M7) : Fuse block
- F4 (M8) : Data link connector for CONSULT
- F4 (M9) : Rear window defogger relay
- F3 (M10) : To (E7) (SMJ)
- F3 (M13) : To (B1) (SMJ)
- G3 (M14) : To (D1)
- G3 (M15) : To (D2)
- G2 (M16) : To (E1)
- F2 (M17) : Pillar speaker RH
- F2 (M18) : Smart entrance control unit
- F3 (M19) : Kickdown switch (A/T models)
- E3 (M20) : Combination meter
- E3 (M21) : Illumination control switch
- E3 (M22) : A/T control unit (A/T models)
- E3 (M23) : Combination flasher unit
- E4 (M24) : Buzzer
- E4 (M25) : Stop lamp switch
- D3 (M26) : In-vehicle sensor (Auto A/C)
- D3 (M27) : Air mix door motor
- D3 (M28) : Mode door motor
- C3 (M29) : Bi-level door motor
- B4 (M30) : To (Z5)
- D2 (M31) : Auto A/C unit (Auto A/C)
- C2 (M32) : Push control unit (Except auto A/C)
- C2 (M33) : Fan switch (Except auto A/C)
- D4 (M34) : Hazard switch (For Europe)
- C3 (M35) : Hazard switch (Except for Europe)
- D4 (M36) : Headlamp washer switch (For Europe)
- C3 (M37) : Rear window defogger switch
- C3 (M38) : Rear fog lamp switch (For Europe)
- D4 (M39) : Security indicator (Except for Europe)
- C4 (M40) : Radio
- C4 (M41) : Not used
- C4 (M42) : Cigarette lighter

- C4 (M43) : Diode (Except for Europe)
- C3 (M44) : Diode (Except for Europe)
- C2 (M45) : Joint connector
- B1 (M46) : Sunload sensor (Auto A/C)
- B1 (M47) : Not used (For Europe)
- C2 (M48) : Intake door motor
- C2 (M49) : Thermo control amplifier
- C2 (M50) : Fan control amplifier (Auto A/C)
- B2 (M51) : To (M19) (Except for Australia)
- B3 (M52) : Fan resistor (Except auto A/C)
- C3 (M53) : Blower motor
- A1 (M54) : Pillar speaker LH
- A2 (M55) : To (M10)
- A2 (M57) : To (M19)
- A3 (M58) : Joint connector (For Europe)
- B4 (M59) : To (E4)
- B4 (M62) : To (E7) (A/T models)
- A3 (M63) : To (B5) (Models with ABS)
- A4 (M66) : Mirror defogger relay (Except for Australia)
- A4 (M67) : Body ground

- B2 (M40) : To (M51)
  - A3 (M102) : Glove box lamp
  - A3 (M103) : Glove box lamp switch
- (Except for Australia)

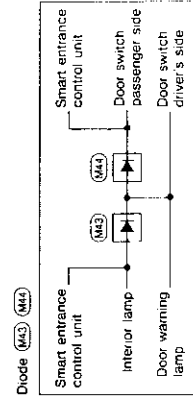

SE1.868T

EL-257

# HARNES LAYOUT

## Engine Room Harness

ENGINE COMPARTMENT (LHD models)

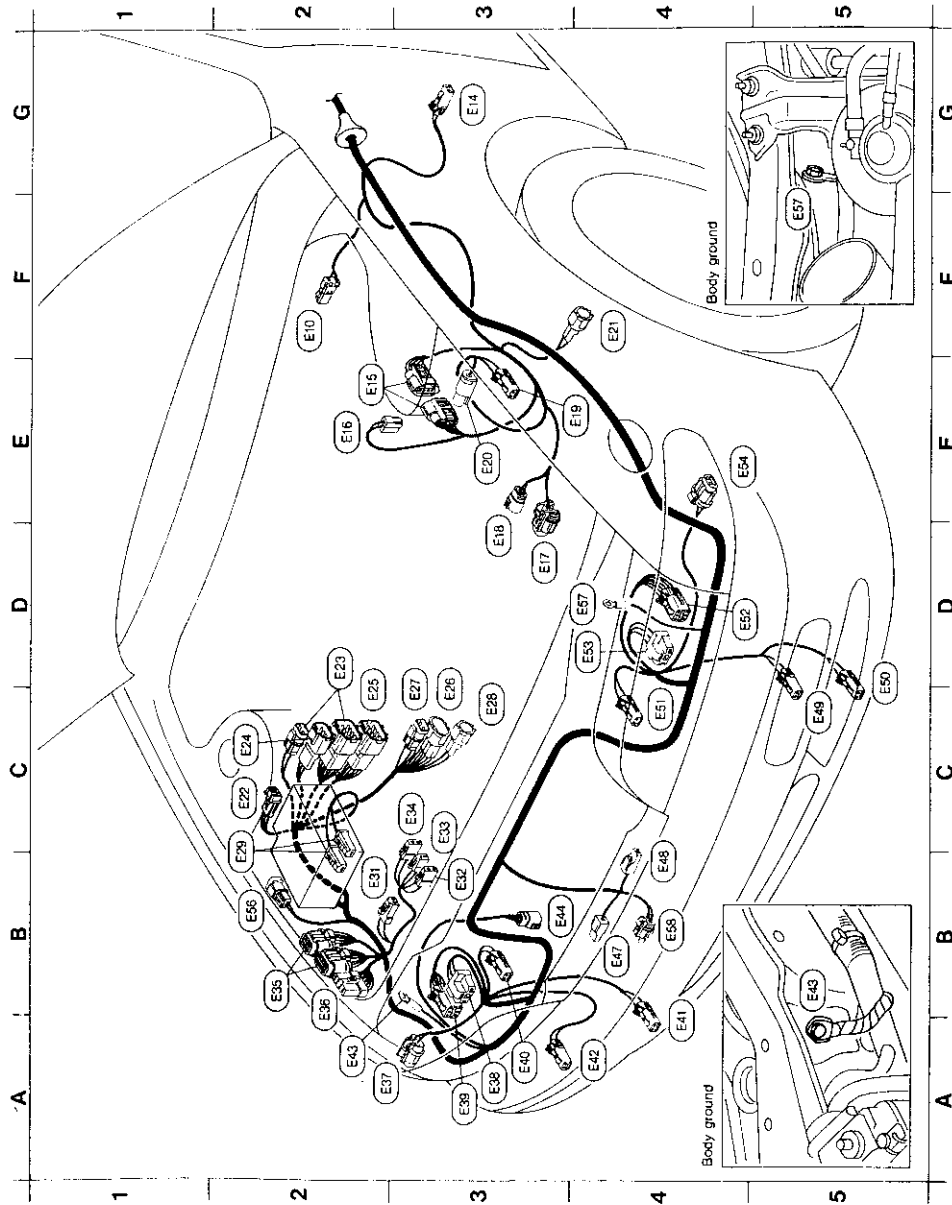

EL-258

# HARNES LAYOUT

## Engine Room Harness (Cont'd)

- B4 (E48) : Horn (Low)
- C5 (E49) : Front turn signal lamp LH
- C5 (E50) : Front fog lamp LH
- C4 (E51) : Headlamp LH inner
- D4 (E52) : Headlamp aiming motor LH
- E4 (E53) : Headlamp LH outer
- E4 (E54) : Clearance lamp LH
- B2 (E55) : To (E20)
- D4 (E56) : Body ground
- B4 (E57) : Ambient sensor (For outside temperature)

- E1 : Cooling fan relay-2
- E2 : Fusible link and fuse block-1
- E3 : Cooling fan relay-1
- E5 : Air conditioner relay
- E6 : Horn relay
- E7 : Front fog lamp relay
- E8 : Fusible link and fuse block-2
- E9 : Fusible link and fuse block-3
- E10 : Brake fluid level switch
- E11 : Side turn signal lamp LH
- E12 : Power transistor unit
- E2 : E16 : Waigate valve control solenoid valve
- E17 : Compressor
- D3 (E18) : Power steering oil pressure switch
- E3 (E19) : Dropping resistor (A/T models)
- E3 (E20) : Check connector
- F4 (E21) : Front wheel sensor LH (For ABS)
- C2 (E22) : Boost pressure sensor
- D2 (E23) : Inhibitor switch (A/T models)
- C2 (E24) : Revolution sensor (A/T models)
- C2 (E25) : To terminal code assembly (A/T models)
- C3 (E26) : To (E20)
- C3 (E27) : To (E20)
- C3 (E28) : To (E20)
- B2 (E29) : Battery
- B2 (E30) : Washer fluid level switch
- B3 (E31) : Headlamp washer motor
- C3 (E32) : Front washer motor
- C3 (E33) : Rear washer motor
- B2 (E34) : Daytime light unit
- B2 (E35) : Headlamp washer amplifier
- A2 (E36) : Clearance lamp RH
- A3 (E37) : Headlamp RH outer
- A3 (E38) : Headlamp aiming motor RH
- A3 (E39) : Headlamp RH inner
- A4 (E40) : Front fog lamp RH
- A4 (E41) : Front turn signal lamp RH
- A2 (E42) : Body ground
- B3 (E43) : Cooling fan motor
- B4 (E44) : Horn (High)

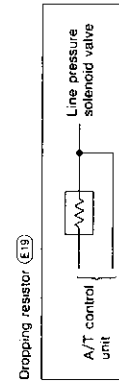
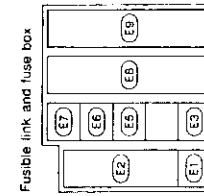

EL-259



# HARNES LAYOUT

## Engine Room Harness (Cont'd)

ENGINE COMPARTMENT (RHD models)

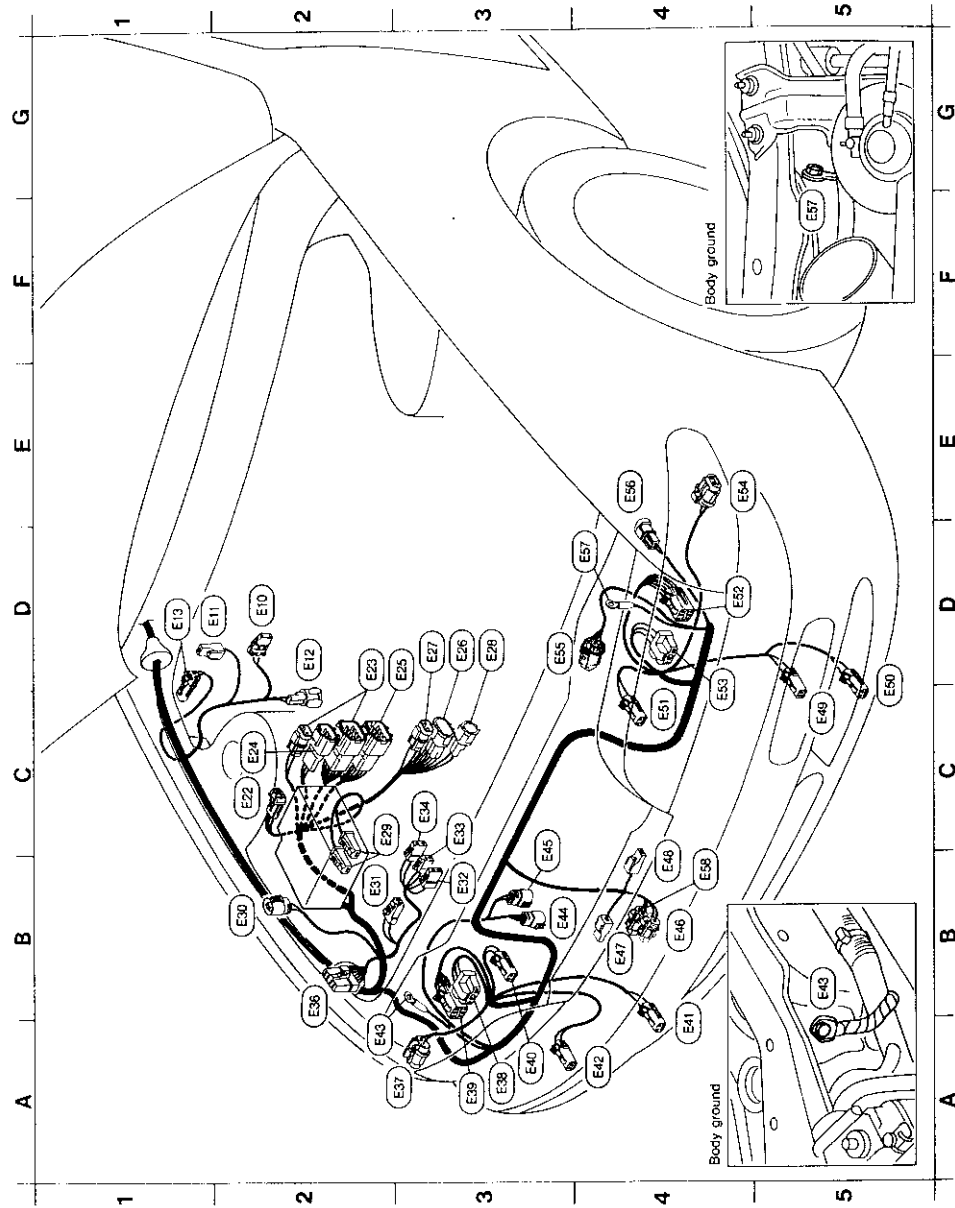

EL-260

# HARNES LAYOUT

## Engine Room Harness (Cont'd)

- C5 (E49) : Front turn signal lamp LH
- C5 (E50) : Front fog lamp LH
- C4 (E51) : Headlamp LH inner
- D4 (E52) : Headlamp aiming motor LH (For Europe)
- C4 (E53) : Headlamp LH outer
- E4 (E54) : Clearance lamp LH
- D3 (E55) : Triple-pressure switch
- E4 (E56) : To (E20)
- D4 (E57) : Body ground
- B4 (E58) : Ambient sensor (For outside temperature)

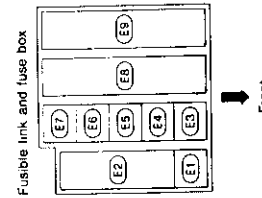

- (E1) : Cooling fan relay-2 (Except for Europe)
- (E2) : Fusible link and fuse block-1
- (E3) : Cooling fan relay-1
- (E4) : Theft warning relay (Except for Europe)
- (E5) : Air conditioner relay
- (E6) : Horn relay
- (E7) : Theft warning horn relay (Except for Europe)
- (E8) : Front fog lamp relay (For Europe)
- (E9) : Fusible link and fuse block-2
- (E10) : Brake fluid level switch
- (E11) : Theft warning horn (Except for Europe)
- (E12) : Front wheel sensor RH (For ABS)
- (E13) : Side turn signal lamp RH
- C1 (E14) : Boost pressure sensor
- D2 (E15) : Inhibitor switch (A/T models)
- C2 (E16) : Revolution sensor (A/T models)
- D3 (E17) : To terminal code assembly (A/T models)
- D3 (E18) : To (E23)
- D3 (E19) : To (E20)
- D3 (E20) : To (E23)
- C2 (E21) : Battery
- B2 (E22) : Hood switch (Except for Europe)
- B2 (E23) : Washer fluid level switch
- B3 (E24) : Headlamp washer motor (For Europe)
- C3 (E25) : Front washer motor
- C3 (E26) : Rear washer motor (Except for Australia)
- B2 (E27) : Headlamp washer amplifier (For Europe)
- A3 (E28) : Headlamp RH outer
- A3 (E29) : Headlamp aiming motor RH (For Europe)
- A3 (E30) : Headlamp RH inner
- A4 (E31) : Front fog lamp RH
- A4 (E32) : Body ground
- A2 (E33) : Body ground
- B3 (E34) : Cooling fan motor (Except for Europe)
- B3 (E35) : Cooling fan motor (For Europe)
- B4 (E36) : Ambient sensor (For auto A/C)
- B4 (E37) : Horn (High)
- B4 (E38) : Horn (Low)

(Fusible link and fuse box)

EL-261

SEL871T

GI  
WA  
EM  
LC  
EC  
FE  
CL  
MT  
AT  
PD  
FA  
RA  
BR  
ST  
TS  
ST  
FA  
EL  
IDX

# HARNESS LAYOUT

## Engine Room Harness (Cont'd)

PASSENGER COMPARTMENT (LHD models)

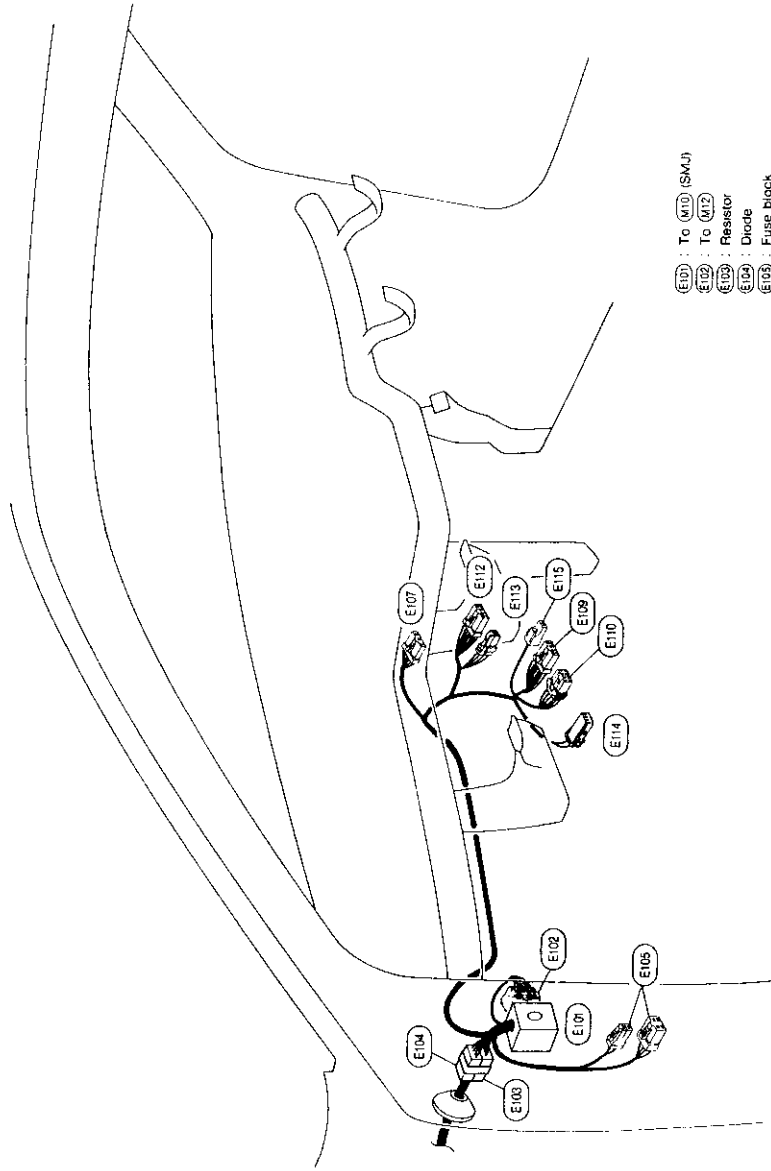

- E101 : To M10 (SMU)
- E102 : To M12
- E103 : Resistor
- E104 : Diode
- E105 : Fuse block
- E106 : Ignition switch
- E107 : Lighting switch
- E108 : Turn signal switch
- E109 : Front wiper and washer switch
- E110 : Rear wiper and washer switch
- E111 : Rear fog lamp switch
- E112 : Horn switch

Resistor (E103)

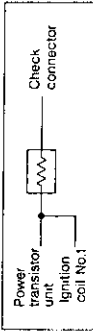

Diode (E108)

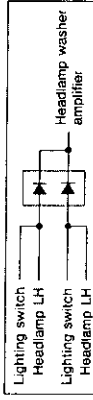

EL-262

SEL870T

# HARNESS LAYOUT

## Engine Room Harness (Cont'd)

PASSENGER COMPARTMENT (RHD models)

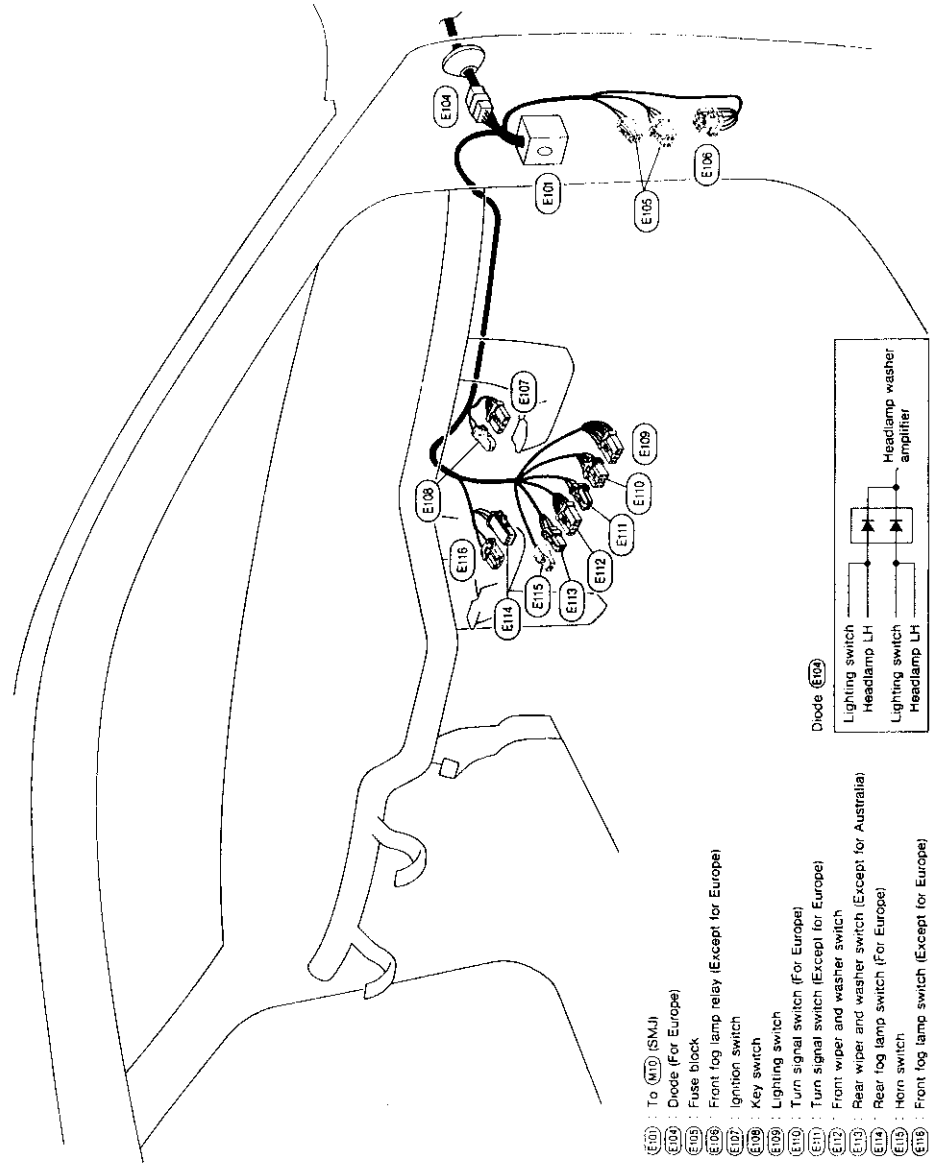

- E101 : To M10 (SMU)
- E102 : Diode (For Europe)
- E103 : Fuse block
- E104 : Front fog lamp relay (Except for Europe)
- E105 : Key switch
- E106 : Ignition switch
- E107 : Lighting switch
- E108 : Turn signal switch (For Europe)
- E109 : Turn signal switch (Except for Europe)
- E110 : Front wiper and washer switch
- E111 : Rear wiper and washer switch (Except for Australia)
- E112 : Rear fog lamp switch (For Europe)
- E113 : Horn switch
- E114 : Front fog lamp switch (Except for Europe)

Resistor (E103)

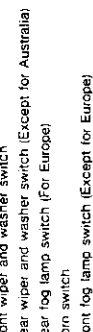

Diode (E108)

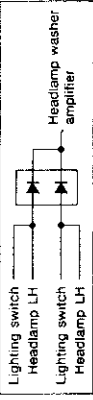

EL-263

SEL872T

EL  
FA  
EM  
LC  
AC  
WA  
CT  
MT  
AT  
PD  
FA  
DA  
DB  
DT  
DA  
SA  
HA  
EL  
FO

# HARNESS LAYOUT

## Engine Control Harness (Cont'd)

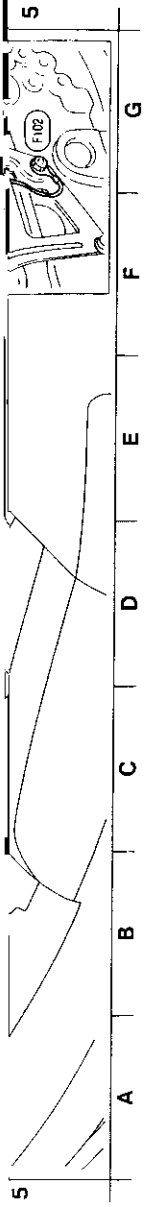

- E2 (E1) : ECM (ECES control module)
- D1 (F2) : ECCS relay
- D1 (F3) : Ignition coil relay
- D1 (F4) : To (M6)
- E1 (F5) : To (E6)
- D1 (F7) : To (M2) (A/T models)
- D1 (F8) : To (M5) (M/T models)
- C1 (F10) : Front wiper motor
- B2 (F11) : Front wiper amplifier
- C1 (F13) : Side turn signal lamp RH
- B1 (F14) : ABS actuator
- B3 (F20) : To (E5)
- D4 (F22) : Mass air flow sensor
- E3 (F24) : To (F10)
- F3 (F25) : Heated oxygen sensor
- E2 (F26) : Engine ground
- E2 (F27) : To (F11)
- D2 (F28) : To (F2)
- E2 (E28) : IACV-FICD solenoid valve
- D2 (F30) : IACV-AAC valve
- D3 (E31) : VTC solenoid valve
- D4 (E32) : Camshaft position sensor
- B3 (F33) : Throttle position sensor (Brown)
- B3 (F34) : Throttle position switch (Gray) (A/T models)
- B3 (F35) : Front wheel sensor RH (For ABS)
- C2 (E36) : Triple-pressure switch
- E2 (F37) : Engine ground

- Sub-harness**
- F3 (F10) : To (F2)
  - F3 (F10) : Engine ground
  - E3 (F10) : Ignition coil No.4
  - E3 (F10) : Ignition coil No.3
  - E3 (F10) : Ignition coil No.2
  - D3 (F10) : Ignition coil No.1
  - E2 (F11) : To (E2)
  - D3 (F12) : Injector No.4
  - C3 (F13) : Injector No.3
  - C3 (F14) : Injector No.2
  - C3 (F15) : Injector No.1
  - C4 (F16) : Engine coolant temperature sensor
  - C4 (F17) : Thermal transmitter
  - D2 (F18) : To (F2)
  - D3 (E22) : Knock sensor

GI  
WA  
EM  
LC  
EC  
EE  
GI  
MT  
AT  
PO  
FA  
BA  
BR  
ST  
ES  
ST  
HA  
EL  
IOX

# WSS LAYOUT

## Engine Control Harness (Cont'd)

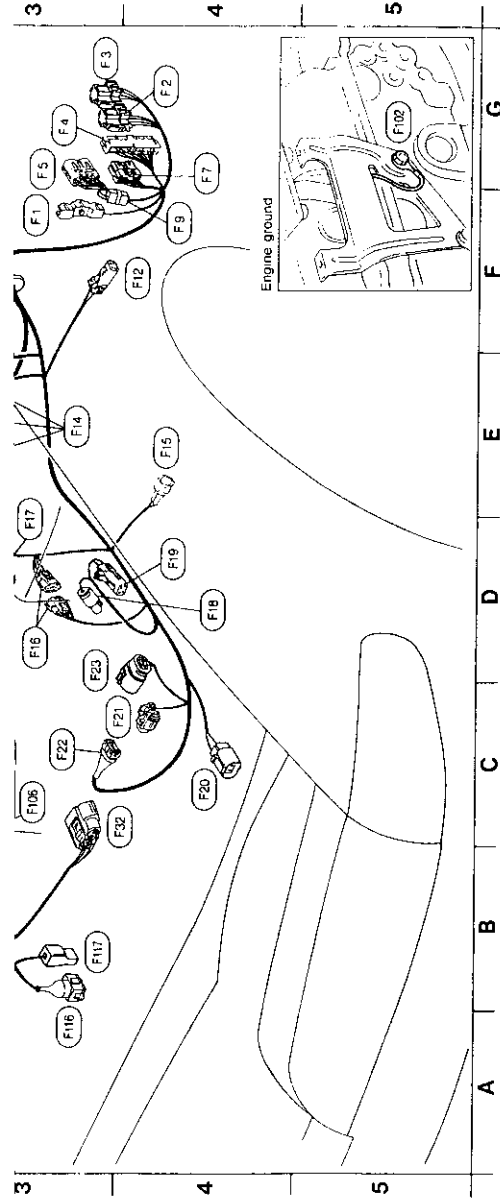

L-266

# HARNESS LAYOUT

## Engine Control Harness (Cont'd)

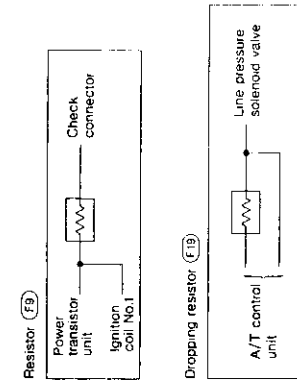

- Sub-harness**
- D2 (F1) : To (E24)
  - D2 (F2) : Engine ground
  - C3 (F3) : Ignition coil No.4
  - C3 (F4) : Ignition coil No.3
  - C3 (F5) : Ignition coil No.2
  - C3 (F6) : Ignition coil No.1
  - D2 (F7) : To (F7)
  - B2 (F8) : Injector No.4
  - B2 (F9) : Injector No.3
  - B2 (F10) : Injector No.2
  - A3 (F11) : Injector No.1
  - B3 (F12) : Engine coolant temperature sensor
  - B3 (F13) : Thermal transmitter
  - B3 (F14) : To (F28)
  - B3 (F15) : Knock sensor

- F3 (F1) : ECM (ECSS control module)
- G4 (F2) : ECCS relay
- G3 (F3) : Ignition coil relay
- G3 (F4) : To (A8)
- G3 (F5) : To (E5) (Model with ABS)
- G4 (F6) : To (A8) (A/T models)
- F4 (F7) : Resistor
- F2 (F8) : Front wiper motor
- F3 (F9) : Front wiper amplifier
- F4 (F10) : Side turn signal lamp LH
- E3 (F11) : ABS actuator (For ABS)
- E4 (F12) : Front wheel sensor LH (For ABS)
- D3 (F13) : Power transistor unit
- D3 (F14) : Wastegate valve control solenoid valve
- D4 (F15) : Check connector
- D4 (F16) : Dropping resistor (A/T models)
- C4 (F17) : To (E5)
- C3 (F18) : Compressor
- C3 (F19) : Mass air flow sensor
- D3 (F20) : Power steering oil pressure switch
- D3 (F21) : To (E1)
- D3 (F22) : Heated oxygen sensor
- C1 (F23) : Engine ground
- C1 (F24) : To (F1)
- B2 (F25) : To (E1)
- B2 (F26) : IACV-FICD solenoid valve
- B2 (F27) : IACV-AAC valve
- B3 (F28) : VTC solenoid valve
- C4 (F29) : Camshaft position sensor
- A2 (F30) : Throttle position sensor (Brown)
- A3 (F31) : Throttle position switch (Gray) (A/T models)
- C1 (F32) : Engine ground

EL-267

Engine Harness

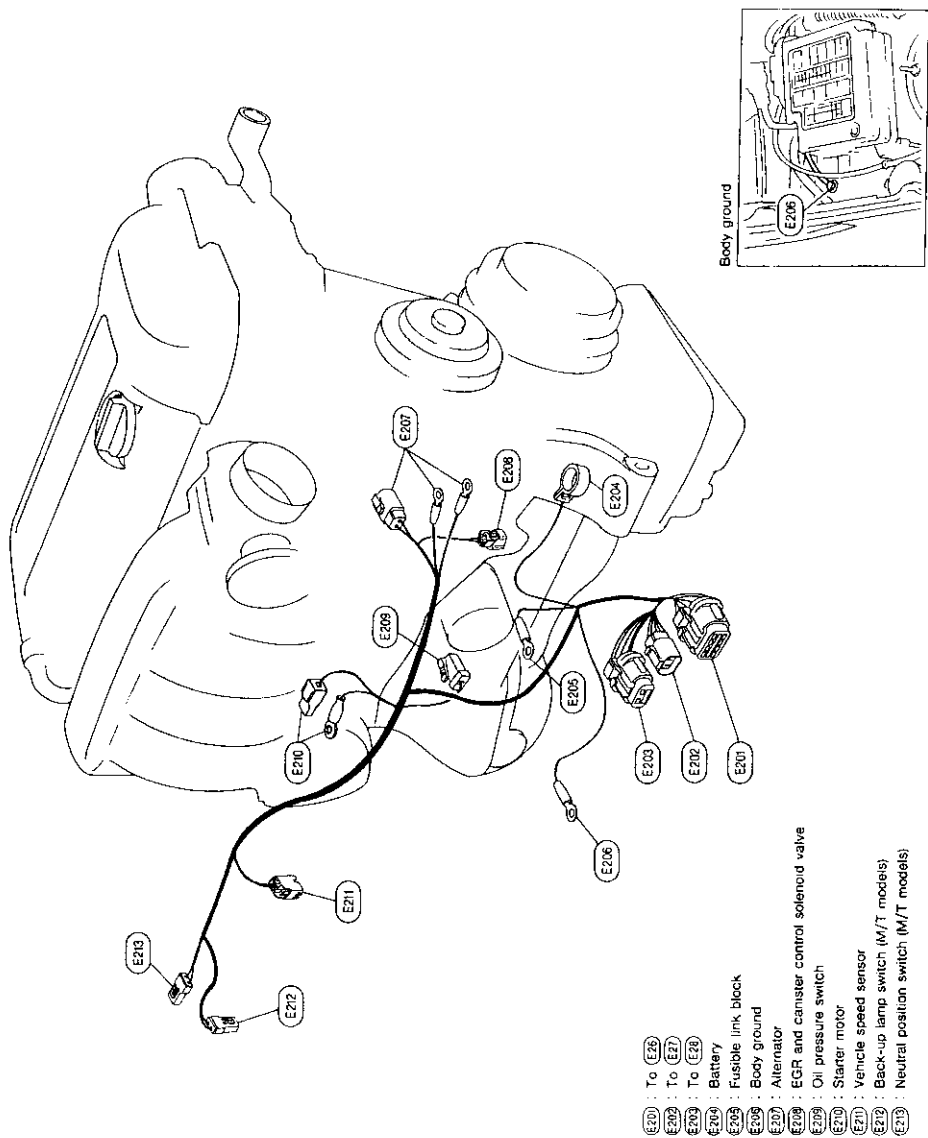

NOTE

GI  
MA  
EM  
LS  
FC  
FE  
OL  
MT  
AT  
PD  
FD  
BA  
BT  
BT  
BA  
EL  
CX

# HARNES LAYOUT

## Body Harness

LHD MODELS

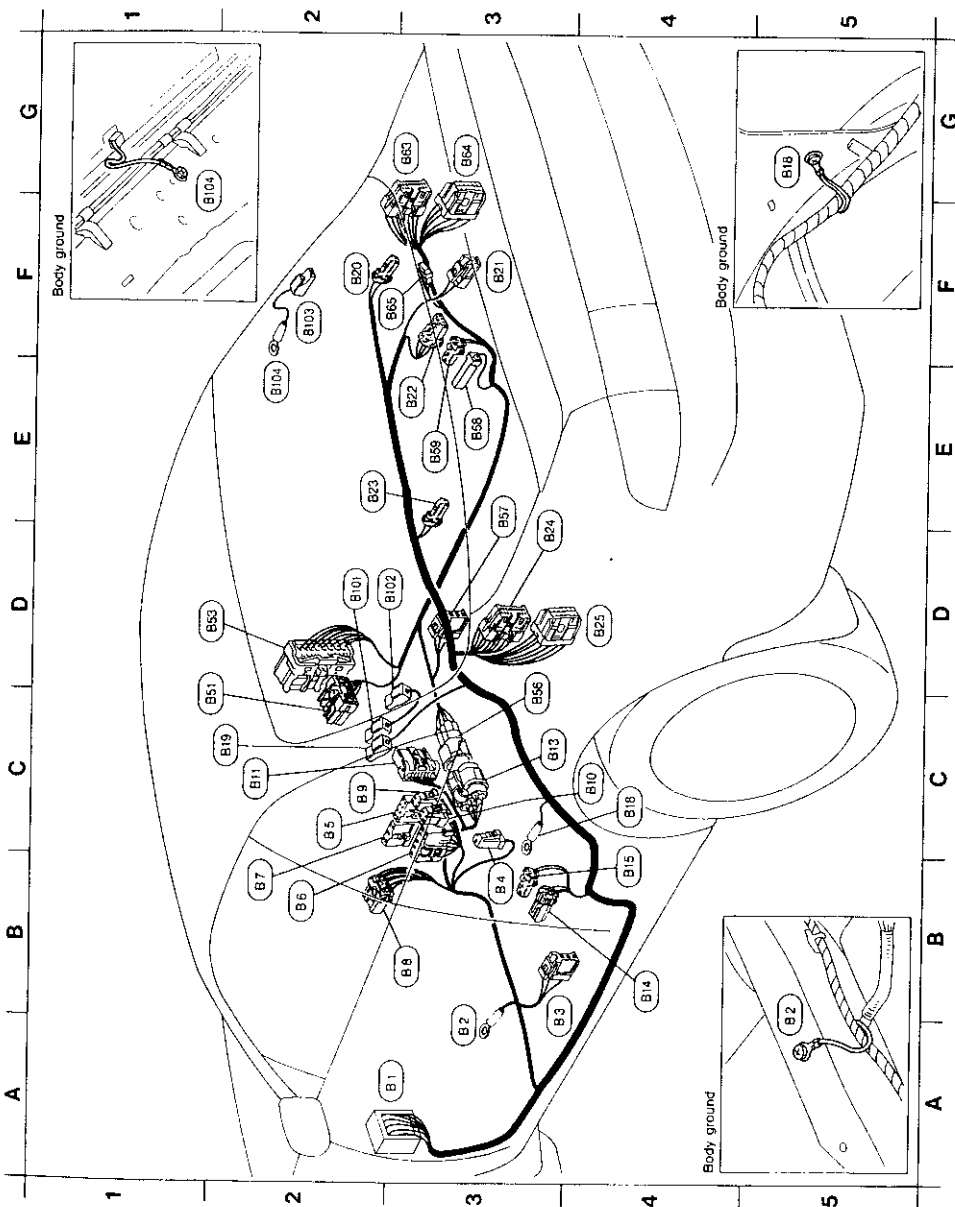

EL-270

# HARNES LAYOUT

## Body Harness (Cont'd)

- Sub-harness**
- D2 (B10) : Condenser (for rear window defogger)
  - F2 (B102) : Rear window defogger (+)
  - E2 (B103) : Rear window defogger (-)
  - (B1) : To (M1)
  - A3 (B2) : Body ground
  - B3 (B3) : Heated seat LH
  - B3 (B4) : Parking brake switch
  - C2 (B5) : Headlamp aiming switch
  - B2 (B6) : Door mirror control switch
  - B2 (B7) : Front fog lamp switch
  - B3 (B8) : Overdrive switch - A/T illumination
  - C2 (B9) : Heated seat switch RH
  - C4 (B10) : Heated seat switch LH
  - C2 (B11) : To (Z2)
  - C3 (B13) : To (G58)
  - B4 (B14) : Door switch (Driver's side)
  - B4 (B15) : Seat belt pre-tensioner (Driver's side)
  - C4 (B16) : Body ground
  - C2 (B19) : Condenser (for rear window defogger)
  - F2 (B20) : Rear speaker RH
  - F3 (B21) : Trunk room lamp
  - E3 (B22) : Rear wiper motor
  - E2 (B23) : Rear speaker LH
  - D3 (B24) : To (T1)
  - D4 (B25) : To (Z2)
  - C2 (B31) : To (M53)
  - D2 (B32) : To (V5)
  - C3 (B36) : To (B13)
  - E3 (B37) : Heated seat RH
  - E3 (B39) : Door switch (Passenger side)
  - E3 (B39) : Seat belt pre-tensioner (Passenger side)
  - G3 (B64) : To (Z6)
  - G3 (B64) : To (Z7)
  - F2 (B85) : Not used

EL-271

# HARNES LAYOUT

## Body Harness (Cont'd)

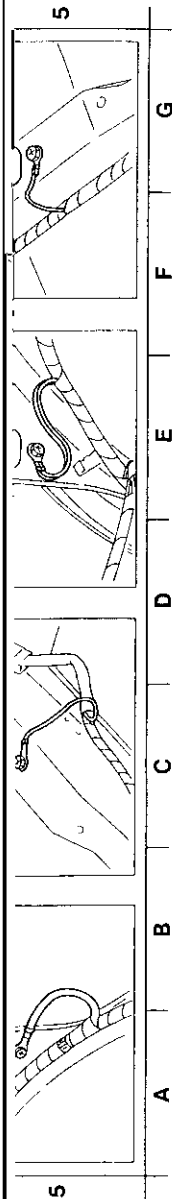

- G3 (81) : To (M1)
- G3 (92) : Body ground
- F3 (84) : Parking brake switch
- F2 (85) : Headlamp aiming switch (For Europe)
- F2 (86) : Door mirror control switch
- F2 (87) : Front fog lamp switch (For Europe)
- E2 (81) : To (Z2)
- E2 (81) : To (825)
- F4 (81) : Door switch (Driver's side)
- F3 (81) : Seat belt pre-tensioner (Driver's side) (For Europe)
- F3 (81) : Multi-remote control relay-1 (Except for Europe)
- E4 (81) : Multi-remote control relay-2 (Except for Europe)
- E3 (81) : Body ground
- E2 (81) : Condenser (For rear window defogger)
- C2 (82) : Rear speaker RH
- B3 (87) : Trunk room lamp
- B3 (87) : Rear wiper motor (Except for Australia)
- B2 (82) : Rear speaker LH
- D3 (82) : To (T1)
- D4 (81) : To (T2)
- E2 (85) : To (M3) (Models with ABS)
- D2 (85) : To (F5) (Models with ABS)
- D3 (84) : Body ground
- E3 (85) : To (812)
- C3 (83) : Door switch (Passenger side)
- C3 (88) : Seat belt pre-tensioner (Passenger side) (For Europe)
- B2 (86) : Body ground (Models with ABS)
- B3 (86) : To (T2) (Models with ABS)
- B3 (86) : ABS control unit (For ABS)
- B2 (85) : Not used (For Europe)

- Sub-harness**
- E2 (810) : Condenser (For rear window defogger)
  - D2 (809) : Rear window defogger (+)
  - C2 (809) : Rear window defogger (-)
  - C2 (804) : Body ground

GI  
MA  
EM  
LC  
EC  
FE  
CL  
MT  
AT  
PD  
FA  
BA  
BR  
BT  
BS  
BT  
BR  
EL  
BOX

# HARNESS LAYOUT

## Tail Harness

### LHD MODELS

- (19) : Fuel tank gauge unit
- (10) : Fuel pump
- (11) : Rear skid sensor (For ABS)
- (12) : Differential oil warning lamp switch
- (13) : Differential oil temperature switch
- (14) : Differential oil cooler relay-1
- (15) : Differential oil cooler relay-2
- (16) : Speed control amplifier
- (17) : Rear combination lamp RH
- (18) : Rear wiper relay
- (19) : Body ground
- (20) : Rear fog lamp
- (21) : License plate lamp
- (22) : Rear combination lamp LH
- (23) : Power antenna timer
- (24) : ABS control unit
- (25) : To (85)
- (26) : To (86)

- (1) : To (824)
- (2) : To (825)
- (3) : High-mounted stop lamp
- (4) : Back-up lamp RH
- (5) : Trunk room lamp switch
- (6) : Back-up lamp LH
- (8) : Differential oil pump

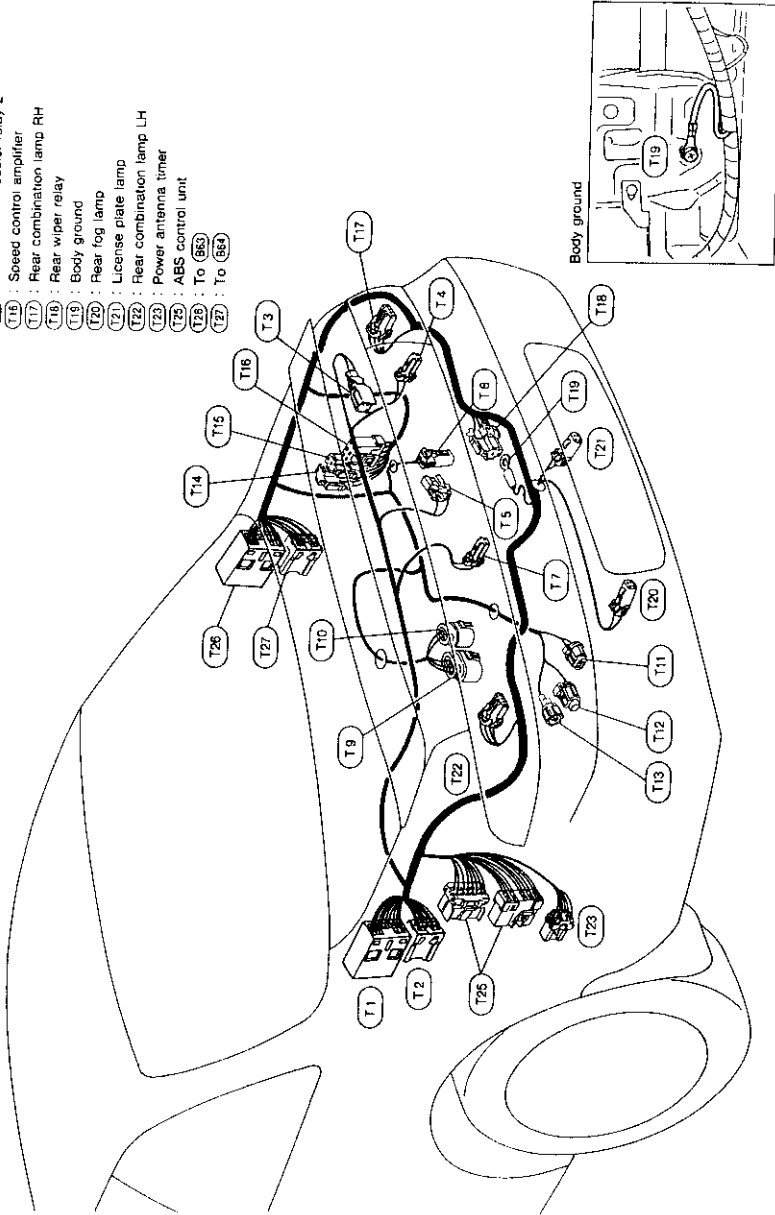

Body ground

EL-274

SEL878T

# HARNESS LAYOUT

## Tail Harness (Cont'd)

### RHD MODELS

- (1) : To (824)
- (2) : To (825)
- (3) : High-mounted stop lamp
- (4) : Back-up lamp RH
- (5) : Trunk room lamp switch
- (6) : Trunk key cylinder switch (Except for Europe)
- (7) : Back-up lamp LH
- (8) : Differential oil pump (For Europe)
- (9) : Fuel tank gauge unit
- (10) : Fuel pump
- (11) : Rear skid sensor (For ABS)
- (12) : Differential oil warning lamp switch (For Europe)
- (13) : Differential oil temperature switch (For Europe)
- (14) : Differential oil cooler relay-1 (For Europe)
- (15) : Differential oil cooler relay-2 (For Europe)
- (16) : Speed control amplifier (For Europe)
- (17) : Rear combination lamp RH
- (18) : Rear wiper relay (Except for Australia)
- (19) : Body ground
- (20) : Rear fog lamp (For Europe)
- (21) : License plate lamp
- (22) : Rear combination lamp LH
- (23) : Power antenna timer
- (24) : To (861) (Models with ABS)

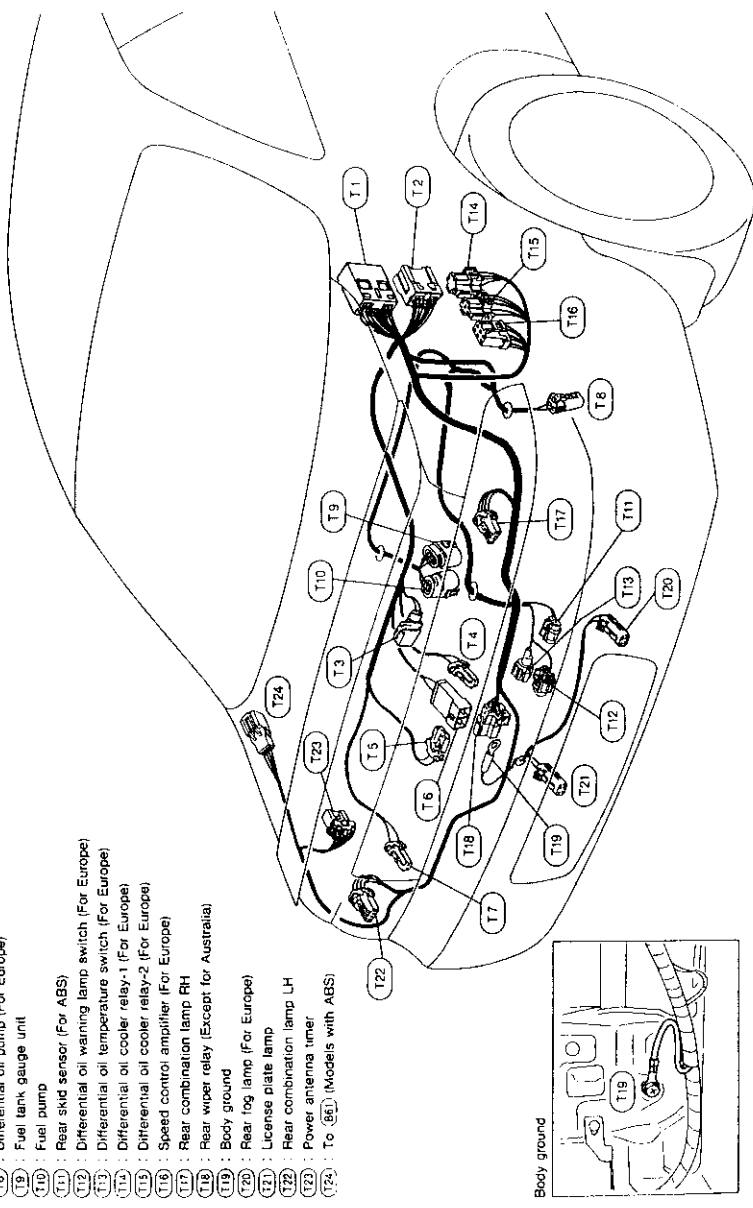

Body ground

EL-275

SEL879T

82 83 84 85 86 87 88 89 90 91 92 93 94 95 96 97 98 99 100

EL



## HARNES LAYOUT

### Room Lamp Harness

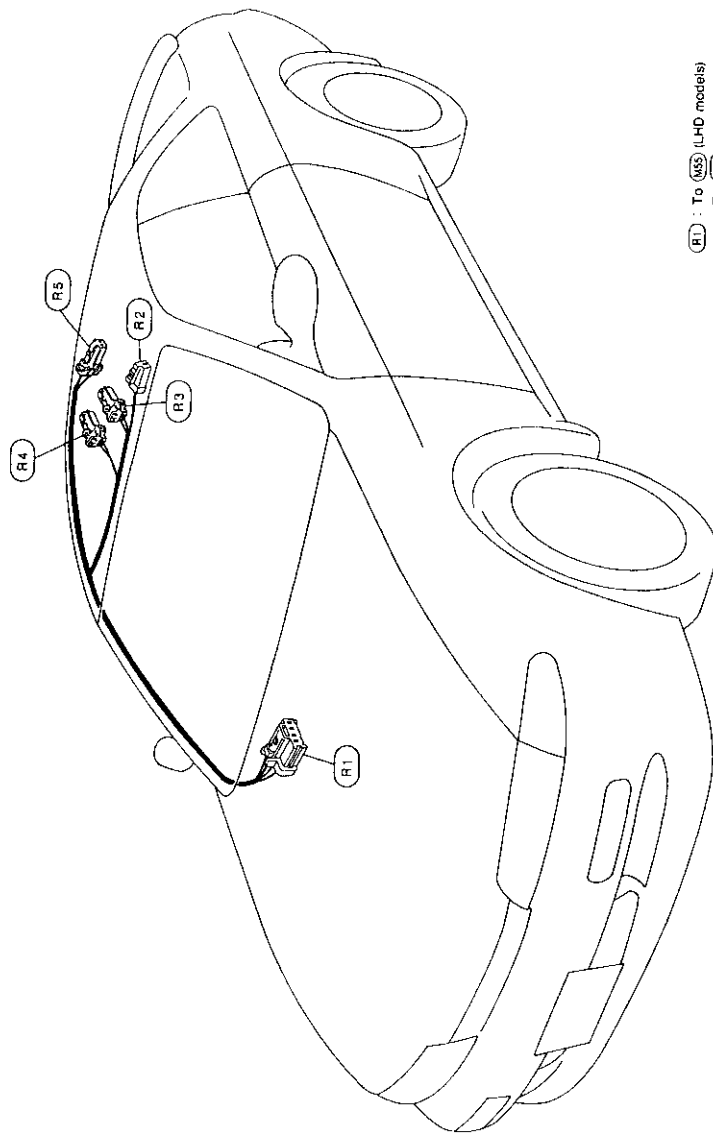

- (R1) : To (M35) (LHD models)  
To (M16) (RHD models)
- (R2) : To sun roof motor assembly
- (R3) : Spot lamp
- (R4) : Interior lamp (Without sun roof)
- (R5) : Interior lamp (With sun roof)

EL-276

SEL880T

## HARNES LAYOUT

### Air Bag and Seat Belt Pre-tensioner Harness

#### LHD MODELS

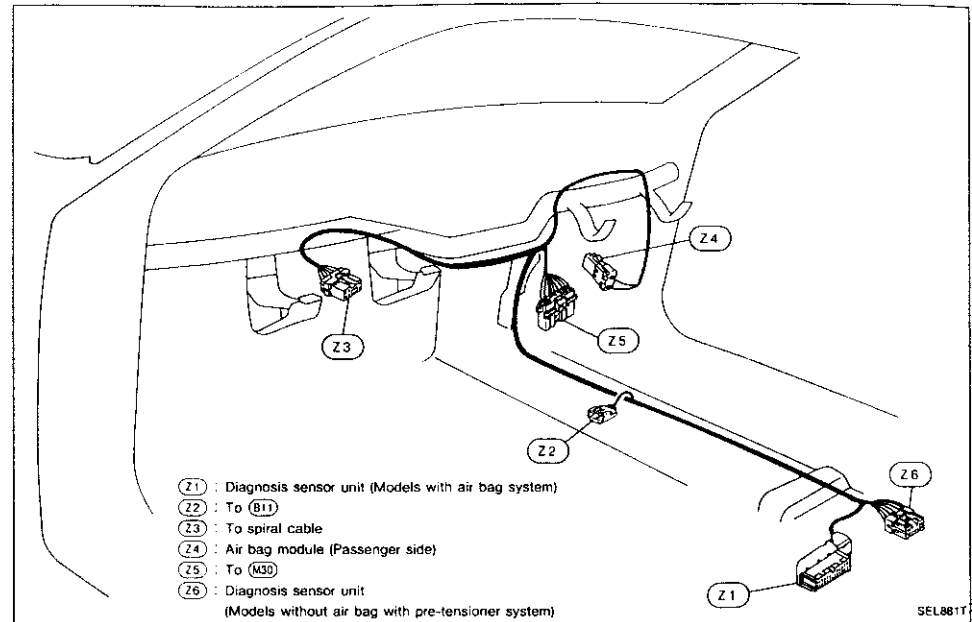

- (Z1) : Diagnosis sensor unit (Models with air bag system)
- (Z2) : To (B11)
- (Z3) : To spiral cable
- (Z4) : Air bag module (Passenger side)
- (Z5) : To (M30)
- (Z6) : Diagnosis sensor unit  
(Models without air bag with pre-tensioner system)

SEL881T

#### RHD MODELS

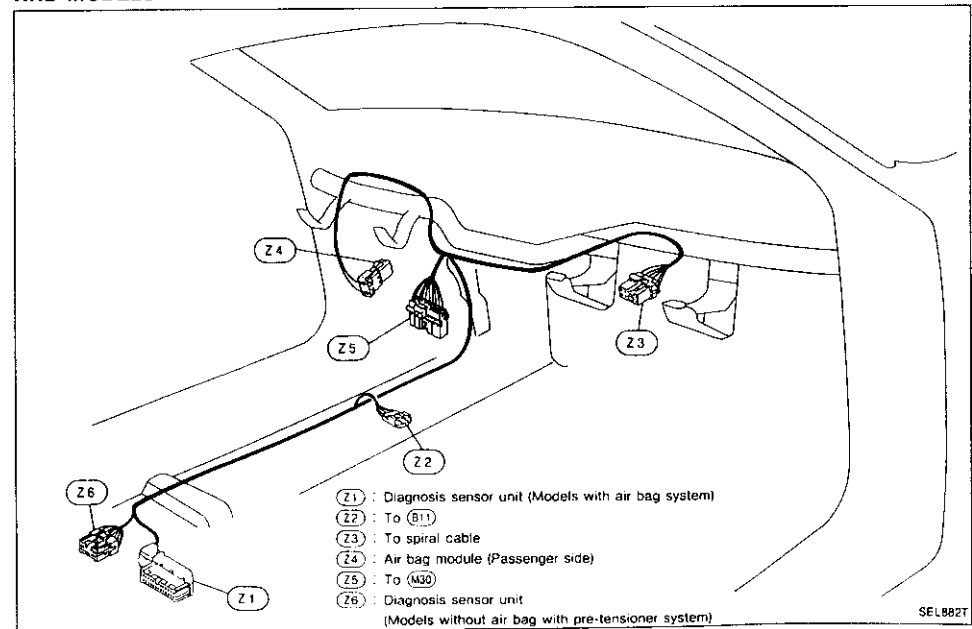

- (Z1) : Diagnosis sensor unit (Models with air bag system)
- (Z2) : To (B11)
- (Z3) : To spiral cable
- (Z4) : Air bag module (Passenger side)
- (Z5) : To (M30)
- (Z6) : Diagnosis sensor unit  
(Models without air bag with pre-tensioner system)

SEL882T

EL-277

GA  
MA  
EM  
LC  
EC  
FE  
CL  
MT  
AT  
PD  
FA  
NA  
BR  
ST  
RS  
BT  
HA  
EL  
DX

## HARNESS LAYOUT

### Door Harness (LHD models)

FRONT LH

- (D1) : To (M14)
- (D2) : To (M15)
- (D3) : Door speaker
- (D4) : Power window regulator
- (D5) : Door mirror defogger
- (D6) : Door mirror
- (D8) : Power window amplifier
- (D9) : Power window main switch
- (D13) : Lock knob switch

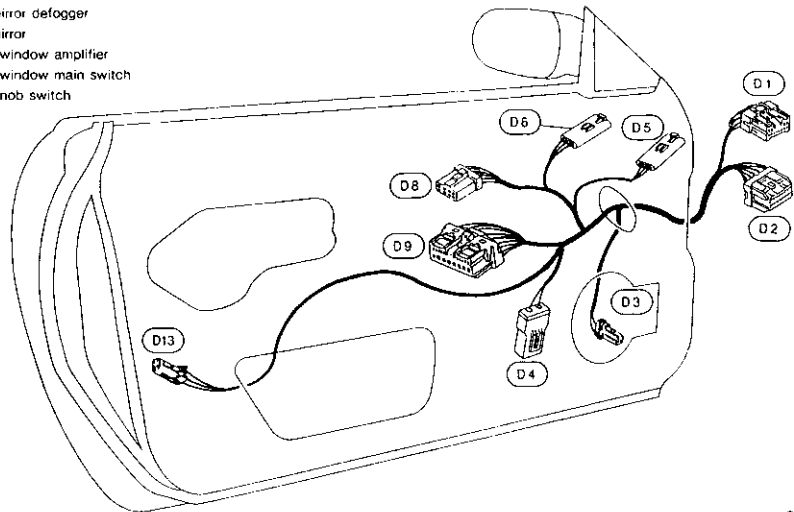

SEL883T

## HARNESS LAYOUT

### Door Harness (RHD models)

FRONT LH

- (D10) : To (M56)
- (D102) : To (M57)
- (D103) : Door speaker
- (D104) : Power window regulator
- (D105) : Door mirror defogger
- (D107) : Door mirror
- (D110) : Power window sub-switch
- (D111) : Key cylinder switch (Except for Europe)
- (D112) : Door lock actuator

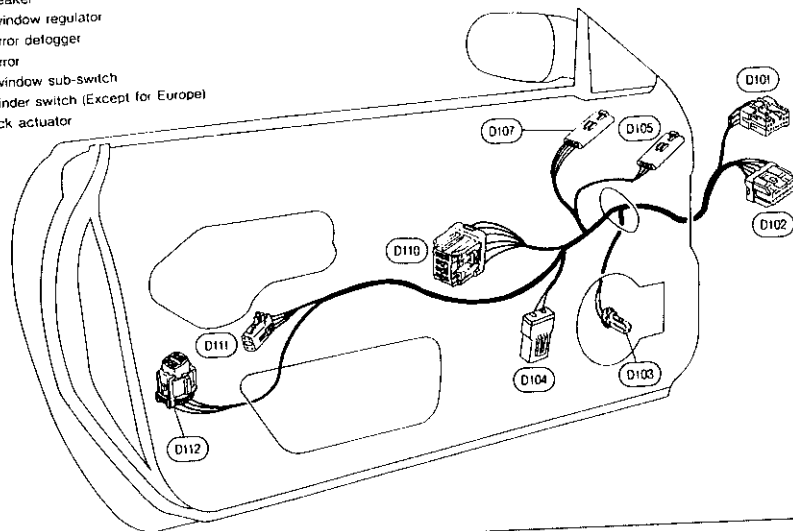

SEL885T

FRONT RH

- (D101) : To (M55)
- (D102) : To (M57)
- (D103) : Door speaker

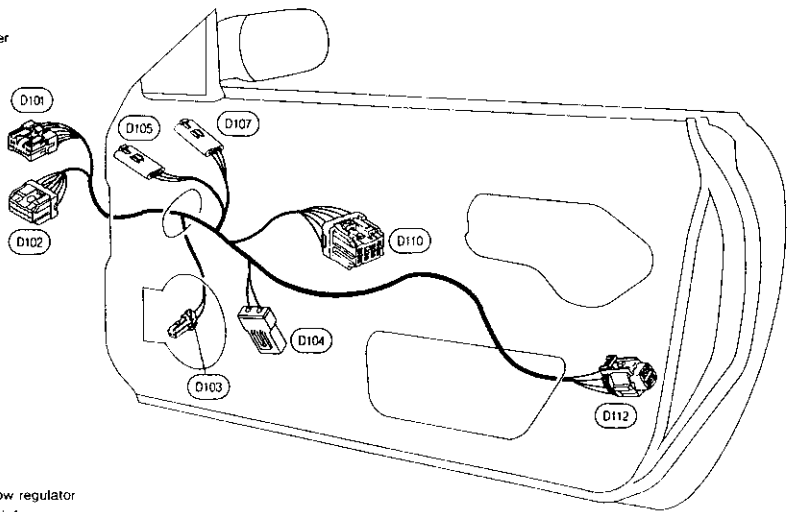

SEL884T

FRONT RH

- (D1) : To (M14)
- (D2) : To (M15)
- (D3) : Door speaker
- (D4) : Power window regulator
- (D5) : Door mirror defogger
- (D7) : Door mirror
- (D8) : Power window amplifier
- (D9) : Power window main switch
- (D11) : Key cylinder switch (Except for Europe)
- (D12) : Door lock actuator (Except for Europe)
- (D13) : Lock knob switch (For Europe)

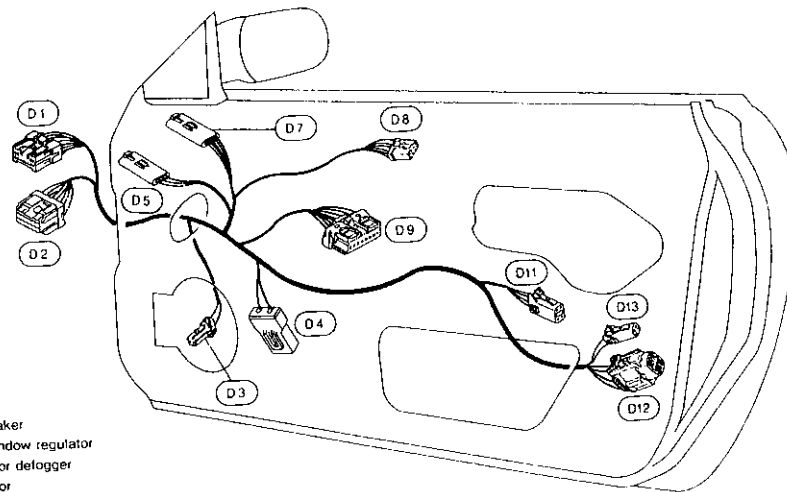

SEL886T

GI  
WA  
EW  
LC  
EC  
FE  
CL  
MT  
AT  
PD  
FA  
RA  
BR  
ST  
RS  
BT  
WA  
EL  
NOX

clutch removal and	
mounting .....	HA-146
precaution .....	HA-144
special service tool .....	HA-5
rod .....	EM-60
rod bearing clearance .....	EM-65
rod bushing clearance .....	EM-66
- See Instrument panel .....	BT-14
ECCS .....	EC-53
eral information .....	GI-33
r (MT) .....	MT-10
e (AT) .....	AT-117
ousing installation .....	AT-96
acement .....	MA-12
uit (engine) .....	LC-10
.....	LC-14
ontrol .....	EC-29
ontrol system .....	LC-14
motor inspection .....	EC-176, 206
relay inspection .....	EC-176, 206
ir (MT) .....	MT-9
eeve (MT) .....	MT-9
emission control system .....	EC-212
assembly .....	EM-68
bearing clearance .....	EM-63
inspection .....	EM-62
ck .....	EM-57
ck boring .....	EM-62
ad .....	EM-38
ad bolt tightening .....	EM-26

D

lnnector for Consult .....	EC-53, 195
ht system .....	EL-56
carrier assembly .....	PD-24
carrier disassembly .....	PD-13
gear oil .....	MA-10
gear oil replacement .....	MA-21
oil cooler system .....	PD-29
.....	GI-38
on system .....	EC-33
.....	BT-11
.....	BT-37
.....	BT-19
- See Front door .....	BT-10
n diff. inspection .....	PD-16
n height .....	PD-17
runout .....	EM-67
(rear) .....	RA-11
esistor (AT) .....	AT-83

E

inspection .....	EC-63
------------------	-------

## ALPHABETICAL INDEX

nsor heater ..... EC-152, 203  
 nsor monitor ..... EC-52  
 ..... BT-29, EL-200  
 ..... EL-185  
 ram ..... HA-37  
 (s) ..... GI-38  
 system precaution ..... HA-3  
 system service ..... HA-138  
 system service ..... HA-6  
 service equipment ..... HA-8  
 ..... AT-134  
 ..... BT-6  
 ..... EL-181  
 chart in trouble ..... GI-30, 37  
 fficient diagnosis ..... GI-19  
 incident ..... GI-9  
 g diagrams ..... GI-7  
 manual ..... EM-45  
 Juster inspection ..... EM-45

oid valve ..... EC-172, 205  
 nspection ..... EC-169, 204  
 ..... GI-37  
 (A/C) system ..... EC-24  
 lve (IACV) ..... EC-15  
 nspection ..... EC-35  
 tion ..... EC-35  
 ction ..... EC-120, 202  
 nspection ..... EC-206  
 ystem ..... EC-120  
 nspection ..... EC-35  
 ..... EL-103  
 ..... HA-128  
 ..... AT-82  
 n ..... EC-156, 205  
 and installation ..... EC-209  
 ..... BT-14  
 ol linkage adjust-  
 ) ..... HA-126  
 ol linkage adjust-  
 A/C) ..... HA-71  
 r ..... HA-135  
 ..... EM-35  
 ..... BT-17  
 ..... EL-103, 110

### K

Knock sensor (KS) ..... EC-16  
 Knock sensor inspection ..... EC-132, 205  
 Knuckle spindle ..... FA-8

### L

Length (Dimensions) ..... GI-38  
 License lamp ..... EL-72  
 Line pressure solenoid valve ..... AT-81  
 Line pressure test (AT) ..... AT-87  
 Liquid gasket application ..... EM-2  
 Location of electrical units ..... EL-249  
 Low and reverse brake ..... AT-140  
 Lower ball joint (rear susp.) ..... RA-20  
 Lubricant (R134a) A/C ..... HA-140  
 Lubricants ..... MA-10  
 Lubrication circuit (engine) ..... LC-4  
 Lubrication-locks, hinges and hood  
 latches ..... MA-24

### M

Magnet clutch ..... HA-146  
 Main drive gear (MT) ..... MT-9  
 Mainshaft (MT) ..... MT-9  
 Maintenance (engine) ..... MA-12  
 Maintenance ..... MA-1  
 Maintenance general ..... MA-4  
 Maintenance periodic ..... MA-5  
 Malfunction indicator lamp (MIL) ..... EC-195  
 Manual transmission number ..... GI-37  
 Manual transmission oil ..... MA-10  
 Manual transmission oil replacement ..... MA-19  
 Mass air flow sensor (MAFS) ..... EC-12  
 Mass air flow sensor inspection ..... EC-113, 201  
 Master cylinder (brake) ..... BR-8  
 Master cylinder (clutch) ..... CL-6  
 Meter and gauges ..... EL-113  
 MIL & Data link connectors circuit ..... EC-195  
 Mirror, door - See Door mirror ..... BT-37  
 Mode door control linkage adjust-  
 ment (auto A/C) ..... HA-125  
 Mode door control linkage adjust-  
 ment (manual A/C) ..... HA-70  
 Mode door motor ..... HA-133  
 Model variation ..... GI-34  
 Molding - See Exterior ..... BT-22  
 MT overhaul ..... MT-8  
 MT removal and installation ..... MT-6  
 Multi link/lower ball joint (rear) ..... RA-20  
 Multi purpose grease ..... MA-10  
 Multi-remote control system ..... EL-202

## ALPHABETICAL INDEX

ear - See Rear seat.....	BT-30	Timing chain .....	EM-19
agnostic results .....	EC-50	Tire rotation.....	MA-21
ontrol (MT) .....	MT-10	Tire size .....	GI-38
ork (MT) .....	MT-10	Tooth contact diff.....	PD-23
chedule.....	AT-32	Torque converter clutch solenoid valve .....	AT-81
lenoid valve (AT).....	AT-81	Torque converter installation.....	AT-96
bsorber (rear) .....	RA-19	Towing points .....	GI-41
earing preload diff.....	PD-19	Transmission case (MT).....	MT-8
im .....	BT-17	Transverse link (front).....	FA-14
indow - See Rear side window .....	BT-36	Tread-FR&RR (Dimensions).....	GI-38
uper multiple junction).....	Foldout page	Trim.....	BT-17
l-filled exhaust valve disposal.....	EM-3	Triple pressure switch.....	HA-69
plug replacement.....	MA-16	Trunk lid.....	BT-8
rometer.....	EL-115	Trunk room lamp .....	EL-110
mp .....	EL-110	Trunk room trim .....	BT-21
ouble diagnoses .....	RS-17	Turbocharger .....	EM-49
er bar (front) .....	FA-13	Turbocharger precautions .....	GI-4
er bar (rear) .....	RA-21	Turn signal lamp.....	EL-93
st (AT).....	AT-84	Two-pole lift.....	GI-40
rdized relay .....	EL-6		
.....	EL-32	V	
g system.....	EL-28	Vacuum hose (brake system).....	BR-11
g gear and linkage inspection .....	MA-23	Vacuum hose drawing (ECCS).....	EC-10
g linkage .....	ST-14	Valve guide inspection .....	EM-42
g wheel and column.....	ST-9	Valve seat inspection .....	EM-43
g wheel play .....	ST-5	Valve spring inspection.....	EM-45
g wheel turning force .....	ST-7	Valve timing control (VTC).....	EC-27
mp.....	EL-80	Valve timing control solenoid valve.....	EC-17
g rod (MT).....	MT-10	Vapor lines inspection .....	MA-17
ront).....	FA-12	Vehicle identification number .....	GI-35
of .....	BT-31	Vehicle speed sensor (VSS).....	EC-16
of, electric - See Electric sun		Vehicle speed sensor inspection.....	EC-145, 202
.....	EL-179	Viscosity number (SAE) .....	MA-11
d sensor .....	HA-129	VTC solenoid valve inspection .....	EC-166, 205
mental Restraint System .....	RS-5		
onizer (MT) .....	MT-9	W	

T	
meter .....	EL-115
mp .....	EL-72
n rod (front).....	FA-13
arning system .....	EL-218
al protector .....	HA-70
o control amp .....	HA-68
ostat .....	LC-12
way catalyst precautions .....	GI-4
e position sensor (TPS).....	EC-13
e position sensor	
ection .....	EC-135, 204
e position switch inspection.....	EC-203
out bearing - See Clutch	
ase bearing .....	CL-8
washer selection diff.....	PD-24
l.....	ST-18
l ball joints .....	ST-18
ring torque of standard bolts.....	GI-42

W	
Warning buzzer.....	EL-130
Warning lamps .....	EL-122
Washer, front.....	EL-138
Washer, rear .....	EL-147
Wastegate valve control solenoid valve .....	EC-17, 163, 205
Water pump .....	LC-11
Water temperature gauge .....	EL-115
Weatherstrip - See Exterior .....	BT-22
Wheel alignment (front).....	FA-5
Wheel alignment (rear).....	RA-5
Wheel balance.....	MA-21
Wheel bearing (front axle).....	FA-5
Wheel bearing (rear) .....	RA-5
Wheel hub (front).....	FA-8
Wheel hub (rear).....	RA-7
Wheel hub and steering knuckle .....	FA-8

## ALPHABETICAL INDEX

Wheel sensors (ABS).....	BR-27	Windshield .....	BT-35
Wheelbase (Dimensions).....	GI-38	Wiper, front .....	EL-138
Width (Dimensions).....	GI-38	Wiper, rear .....	EL-147
Window, rear - See Rear window .....	BT-35	Withdrawal lever (clutch).....	CL-8
Window, side - See Rear side window .....	BT-36		

## SUPER MULTIPLE JUNCTION (SMJ)

### Disconnecting and Connecting

- SMJ is located on left side of dash.
- To disconnect SMJ, loosen fixing bolt.

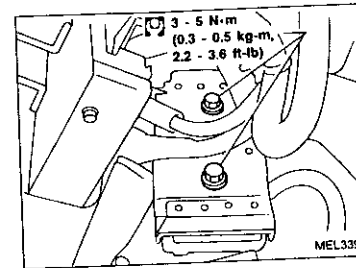

- To install SMJ, tighten bolts until orange "full-tight" mark appears and then retighten to specified torque as required.

3 - 5 N·m  
(0.3 - 0.5 kg-m, 2.2 - 3.6 ft-lb)

**CAUTION:**  
Do not overtighten bolts, otherwise, they may be damaged.

# SUPER MULTIPLE JUNCTION (SMJ)

## Terminal Arrangement

LHD MODELS

MAIN HARNESS

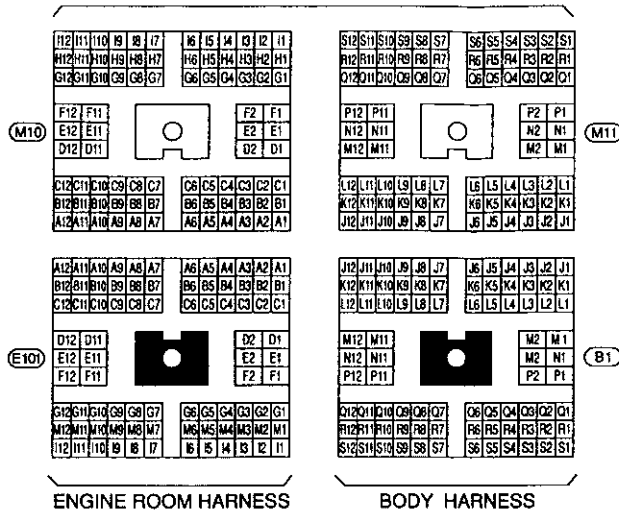

RHD MODELS

MAIN HARNESS

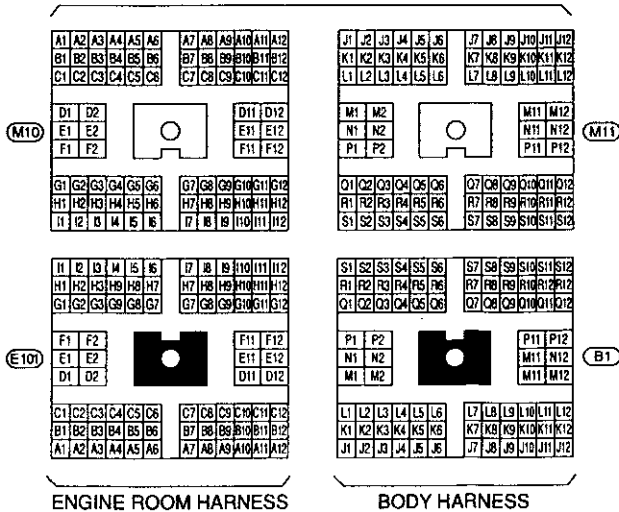

# SUPER MULTIPLE JUNCTION (SMJ)

## Terminal Arrangement (Cont'd)

ENGINE CONTROL HARNESS

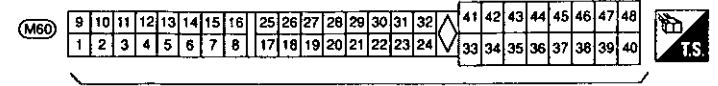
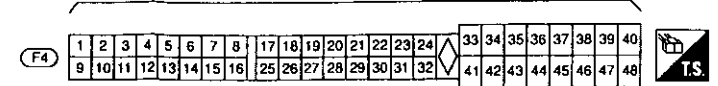

MAIN HARNESS

ECM (ECCS CONTROL MODULE)

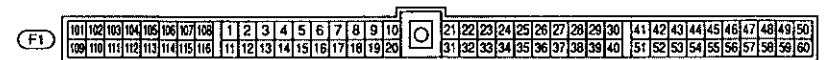

View from harness side

A/T CONTROL UNIT

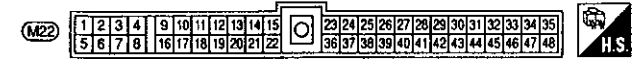

View from harness side

SMART ENTRANCE CONTROL UNIT

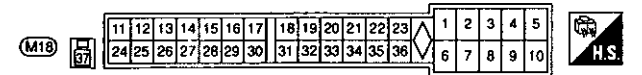

View from harness side

## Engine Control

System utilizing timers with enhanced real-time processing functions, high-precision A-D converter, and high-speed processing.

Memory with large internal ROM and RAM (M6M72561J) is used.

