

ABS

ANTI-LOCK BRAKE SYSTEM (ABS)

ABS

1. Anti-lock Brake System (ABS)

A: FEATURES

- To reduce the size and weight, this ABS has a hydraulic control unit, an ABS control module, a valve relay and a motor relay integrated into a single unit (called ABSCM & H/U).
- The ABS electrically controls the brake fluid pressure to each wheel to prevent the wheel from locking during braking on slippery road surfaces, thereby enabling the driver to maintain the directional control.
- If the ABS becomes inoperative, a fail-safe system is activated to ensure same level of braking performance as with a conventional brake system. In that case, the warning light comes on to indicate that the ABS is malfunctioning.
- The ABS is a 4-sensor, 4-channel system. The system is a four-wheel independent control type, which controls each of the wheel brakes individually.

ANTI-LOCK BRAKE SYSTEM (ABS)

ABS

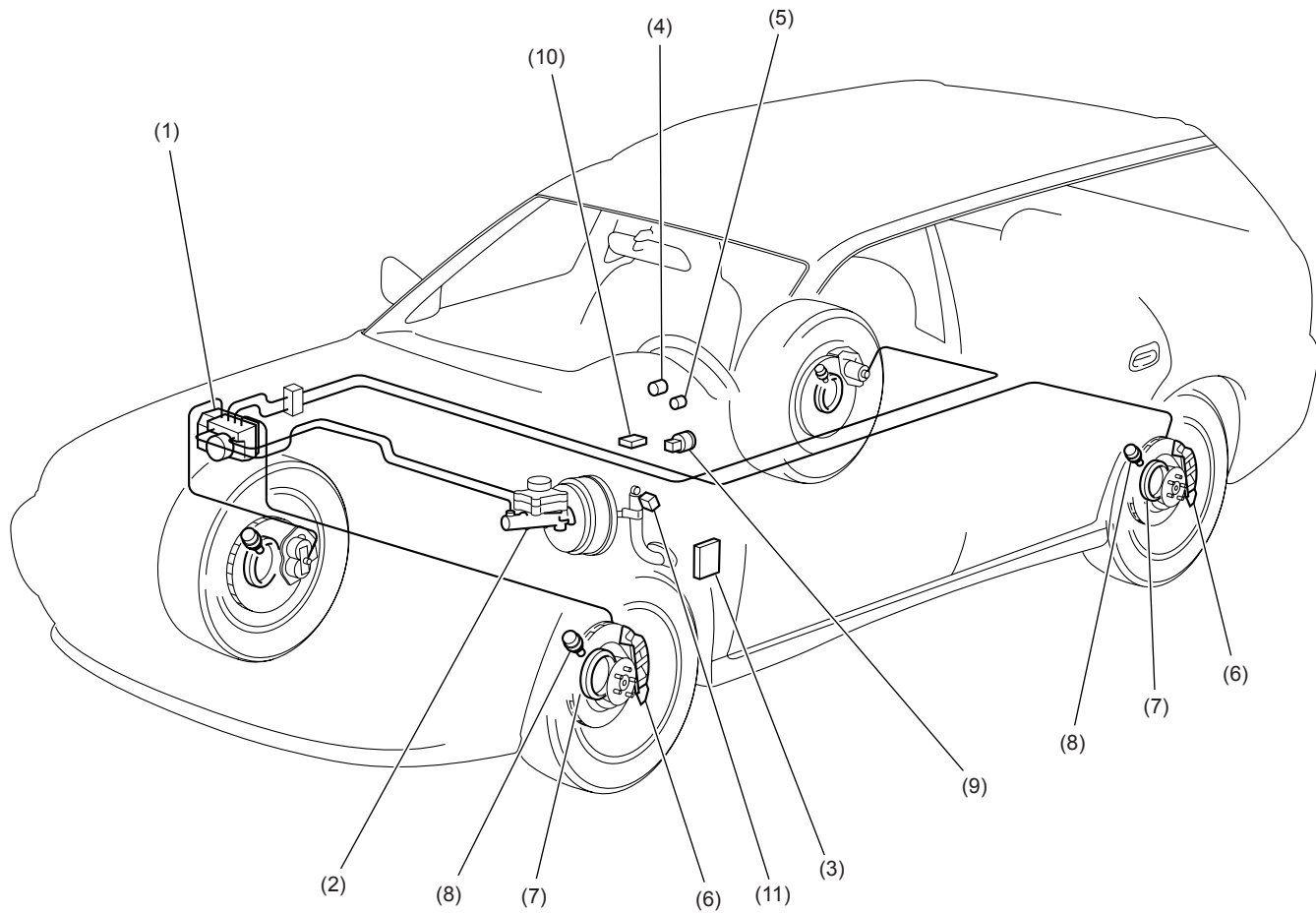

ABS00575

- | | | |
|---|-------------------------------|--|
| (1) ABS control module and hydraulic control unit (ABSCM & H/U) | (5) Brake & EBD warning light | (9) G sensor |
| (2) Master cylinder | (6) Wheel cylinder | (10) Data link connector (for SUBARU select monitor) |
| (3) Transmission control module (AT models only) | (7) Magnetic encoder | (11) Stop light switch |
| (4) ABS warning light | (8) ABS wheel speed sensor | |

ANTI-LOCK BRAKE SYSTEM (ABS)

ABS

B: FUNCTIONS OF SENSORS AND ACTUATORS

Name		Function
ABS control module and hydraulic control unit (ABSCM & H/U)	ABSCM section	<ul style="list-style-type: none"> ● It determines the conditions of the wheels and the vehicle body from the wheel speed data and controls the hydraulic unit depending on the result. ● When the ABS is active, the ABSCM provides the automatic transmission control module with control signals which are used by the module for cooperative control of the vehicle with the ABSCM. ● Whenever the ignition switch is placed at ON, the module performs a self diagnosis sequence. If anything wrong is detected, the module cuts off the system. ● It communicates with the SUBARU select monitor.
	H/U section	<ul style="list-style-type: none"> ● When the ABS is active, the H/U changes fluid passages to the wheel cylinders in response to commands from the ABSCM. ● It constitutes the brake fluid passage from the master cylinder to the wheel cylinders together with the piping.
	Valve relay section	It serves as a power switch for the solenoid valves. It operates in response to a command from the ABSCM.
	Motor relay section	It serves as a power switch for the pump motor. It operates in response to a command from the ABSCM.
ABS wheel speed sensor		Detects speed of each wheel and sends to the ABSCM.
Magnetic encoder		Incorporated with the hub unit bearing and causes the ABS wheel speed sensor to generate electrical signals.
G sensor		It detects a change in acceleration in the longitudinal direction of the vehicle and outputs it to the ABSCM as a voltage signal.
Stop light signal		Detects ON-OFF status of the brake pedal and sends to the ABSCM. The ABSCM uses it to determine ABS operation.
ABS warning light		It alerts the driver to an ABS fault.
Automatic transmission control module		It provides gear controls and changing power transmission to front and rear wheels in response to control signals from the ABSCM.
Brake warning light		It alerts the driver to an EBD fault. This warning light is also used for parking brake warning and brake fluid level warning.

ANTI-LOCK BRAKE SYSTEM (ABS)

ABS

MEMO

ANTI-LOCK BRAKE SYSTEM (ABS)

ABS

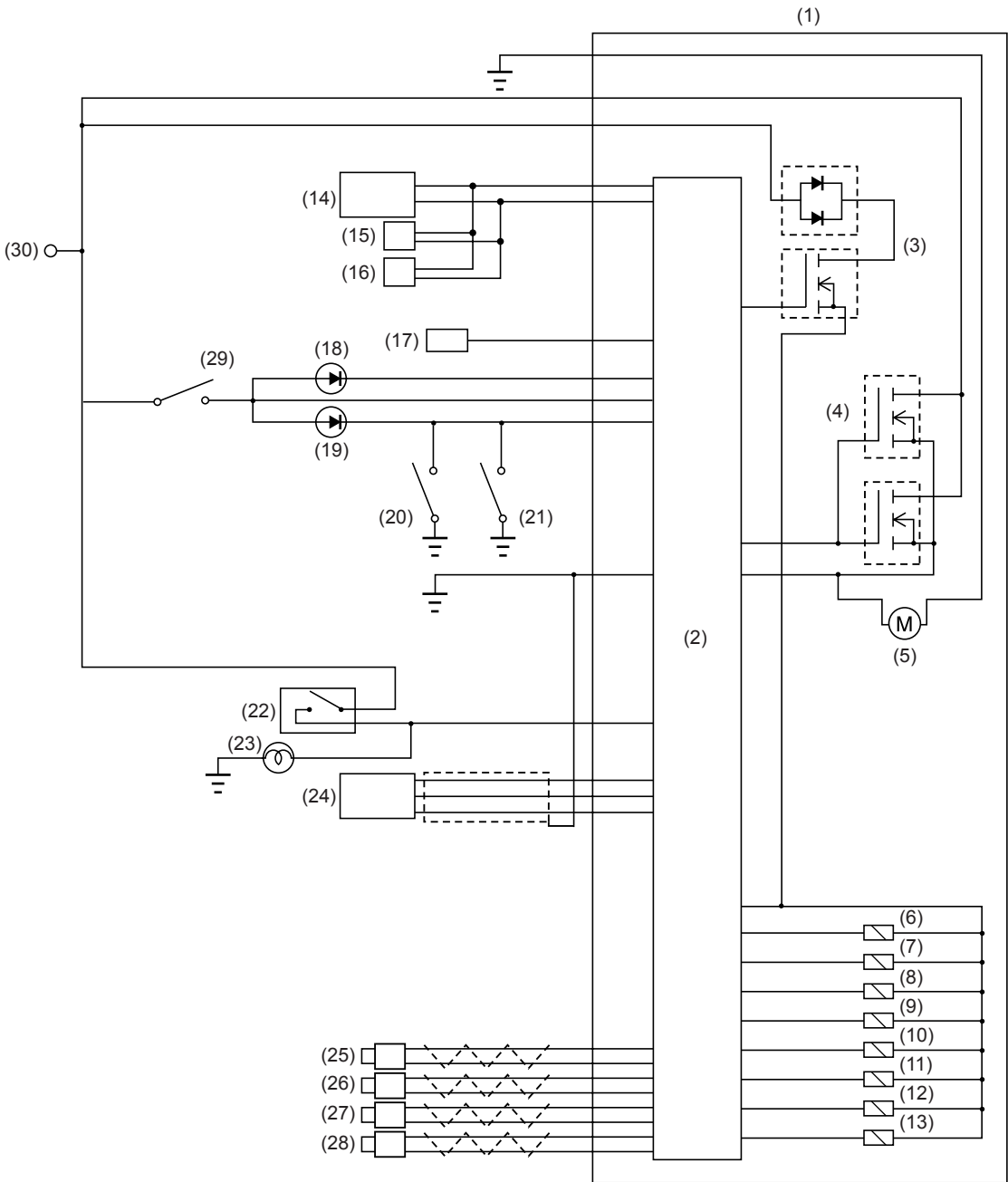

ABS00576

ANTI-LOCK BRAKE SYSTEM (ABS)

ABS

- | | | |
|---|--|---|
| (1) ABS control module and hydraulic control unit | (11) Rear left outlet solenoid valve | (21) Brake fluid level switch |
| (2) ABS control module section | (12) Rear right inlet solenoid valve | (22) Stop light switch |
| (3) Valve relay | (13) Rear right outlet solenoid valve | (23) Stop light |
| (4) Motor relay | (14) Automatic transmission control module | (24) G sensor |
| (5) Motor | (15) Body integrated unit | (25) Front left ABS wheel speed sensor |
| (6) Front left inlet solenoid valve | (16) Engine control module | (26) Front right ABS wheel speed sensor |
| (7) Front left outlet solenoid valve | (17) Data link connector | (27) Rear left ABS wheel speed sensor |
| (8) Front right inlet solenoid valve | (18) ABS warning light | (28) Rear right ABS wheel speed sensor |
| (9) Front right outlet solenoid valve | (19) Brake warning light | (29) IGN |
| (10) Rear left inlet solenoid valve | (20) Parking brake warning light switch | (30) Battery |

ANTI-LOCK BRAKE SYSTEM (ABS)

ABS

C: PRINCIPLE OF ABS CONTROL

When the brake pedal is depressed during driving, the wheel speed decreases and the vehicle speed does as well. The decrease in the vehicle speed, however, is not always proportional to the decrease in the wheel speed. The non-correspondence between the wheel speed and vehicle speed is called “slip” and the magnitude of the slip is expressed by the “slip ratio” which is defined as follows:

$$\text{Slip ratio} = (\text{Vehicle speed} - \text{Wheel speed}) / \text{Vehicle speed} \times 100\%$$

When the slip ratio is 0%, the vehicle speed corresponds exactly to the wheel speed. When it is 100%, the wheels are completely locking while the vehicle is moving.

The braking effectiveness is represented by the “coefficient of friction” between the tire and road surface. The larger the coefficient, the higher the braking effectiveness. The diagram below shows the relationship between the coefficient of friction and the slip ratio for two different road surface conditions (asphalt-paved road and icy road), assuming that the same tires are used for both the conditions and the vehicles are moving forward. Although the braking effectiveness (coefficient of friction) depends on the road surface condition as shown and also on the type of the tire, its peak range generally corresponds to the 8 — 30% range of the slip ratio.

The ABS controls the fluid pressure to each wheel to maintain the slip ratio within this range.

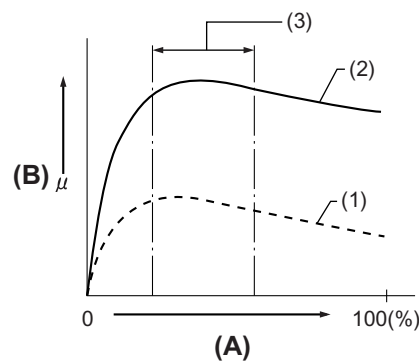

ABS00007

(A) Slip ratio

(B) Coefficient of friction between tire and road surface

(1) Icy road

(2) Asphalt-paved road

(3) Control range by ABS

D: ABS WHEEL SPEED SENSOR

Each of the ABS wheel speed sensors detects the speed of the corresponding wheel. The sensor consists of a sensor body and a magnetic encoder. The magnetic encoder is a permanent magnet with N poles and S poles arranged alternately, and when this turns together with the wheel the magnetic field at the sensing area of the sensor body changes. The sensor body has a hall element and outputs signals at a frequency proportional to the wheel speed.

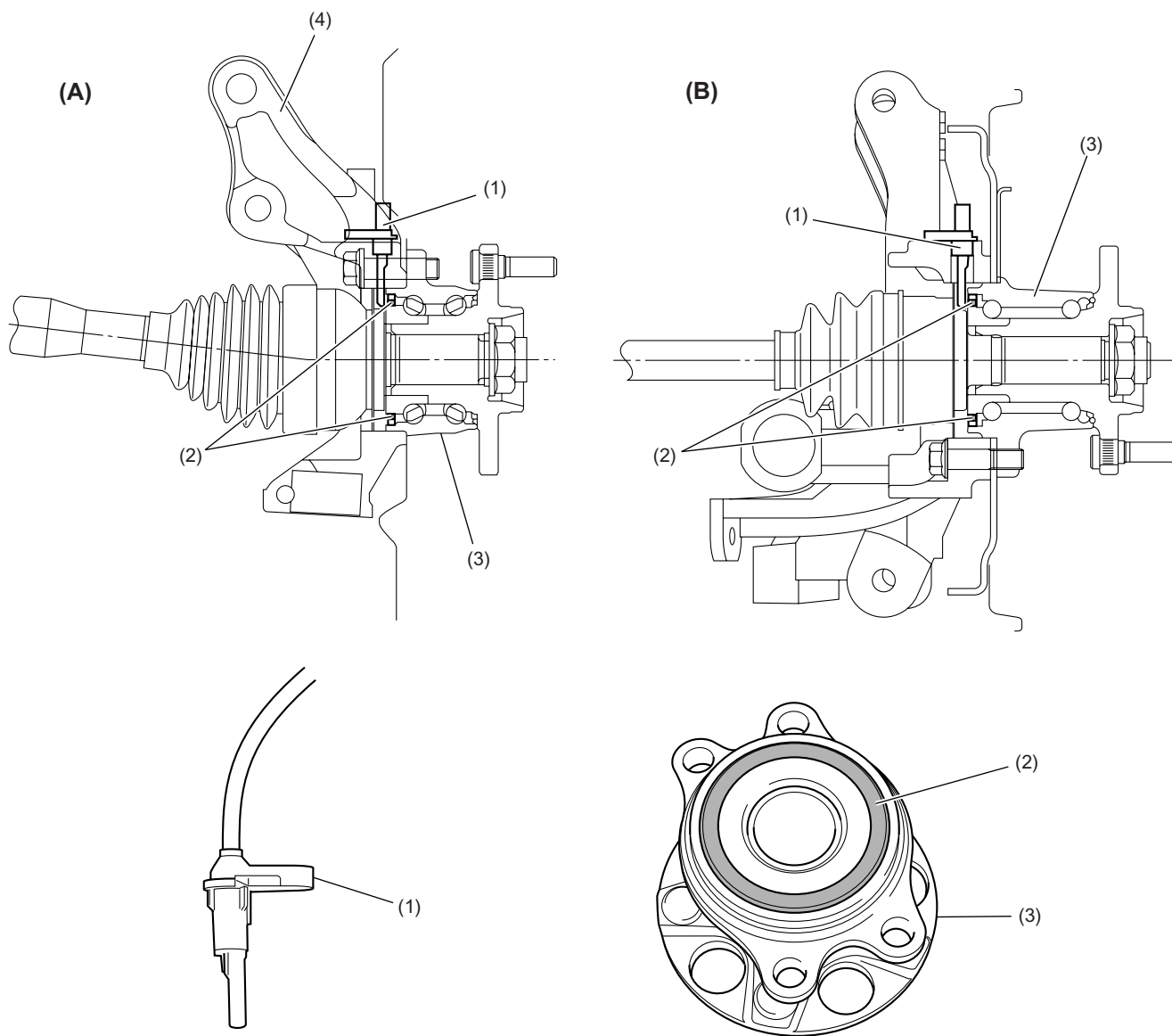

ABS00423

(A) Front
(B) Rear

(1) Sensor body
(2) Magnetic encoder

(3) Hub unit bearing
(4) Housing

ANTI-LOCK BRAKE SYSTEM (ABS)

ABS

E: EBD (ELECTRONIC BRAKE FORCE DISTRIBUTION)

The EBD system utilizes the function of the conventional ABS. This system prevents premature locking of the rear wheels by using electronic control instead of a proportioning valve. The system provides a feature to optimize the brake force distribution to the front and rear wheels according to change in loading conditions or displacement of the center of gravity during deceleration.

The ABSCM calculates the optimum brake force distribution from the difference in speed between the front and rear wheels. Based on the results, the ABSCM controls the rear wheel brake pressure through the ABS hydraulic unit (H/U) to achieve the optimum brake force distribution suitable for the driving condition.

The proportioning valve is disused on EBD equipped vehicles.

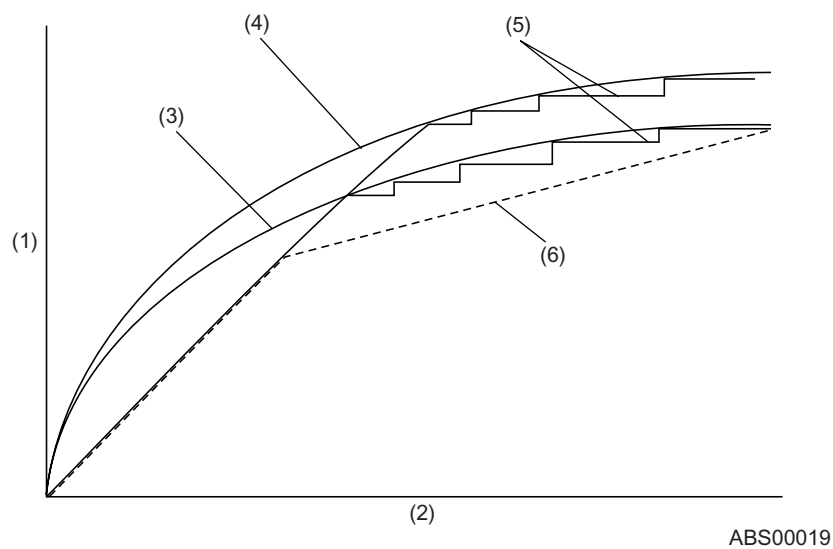

- (1) Brake force to rear wheels
- (2) Brake force to front wheels
- (3) Optimum brake force distribution for light loaded conditions
- (4) Optimum brake force distribution for heavy loaded conditions
- (5) EBD controlled brake force distribution
- (6) PCV controlled brake force distribution (reference)

F: ABS CONTROL MODULE AND HYDRAULIC CONTROL UNIT (ABSCM & H/U)

- **ABS control module section (ABSCM)**

The ABSCM contains two micro control modules (MCMs) which communicate with each other. Both the MCMs process the same program and each MCM monitors the other's outputs. If a mismatch occurs between their outputs, the ABSCM cuts off the system and activate the fail-safe function.

The ABSCM can store a maximum of 3 diagnostic trouble codes (DTC) in a ROM. If more than 3 faults have occurred, only the 3 most recent failures are stored and others are erased. Trouble diagnostic trouble codes remain stored until they are internally or externally erased.

The ABSCM has a test routine (sequence control pattern) which facilitates checking of the hydraulic control unit.

- **ABS control**

Using primarily the wheel speed data from each ABS wheel speed sensor and secondarily the vehicle deceleration rate data from the G sensor as parameters, the ABSCM generates a simulated vehicle speed when there is a risk of wheel lock-up. Using the simulated vehicle speed (called "dummy" vehicle speed) as a reference, the ABSCM determines the state of the wheel in terms of the tendency toward lock-up. If the result shows that the wheels are about to lock, the ABSCM issues commands to energize or de-energize the solenoid valves and activate the motor pump of the H/U to modulate the brake fluid pressures that act on the wheel cylinders, thereby preventing the wheels from locking.

The ABSCM controls the fluid pressure to each of the four wheels independently.

- **Functions available using SUBARU select monitor**

When the SUBARU select monitor is connected, the ABSCM allows it:

- To read out analog data
- To read out ON/OFF data
- To read out or erase diagnostic trouble codes
- To read out data showing conditions under which a trouble code has been stored (freeze frame data)
- To initiate ABS sequence control pattern

- **Indication functions**

Under the control of the ABSCM, the ABS warning light provides the following two indication functions:

- ABS fault alerting
- Valve ON/OFF indication (when sequence control pattern is initiated)

ANTI-LOCK BRAKE SYSTEM (ABS)

ABS

- **Hydraulic control unit section (H/U)**

The H/U is a fluid pressure controller consisting of, among others, a motor, solenoid valves, a housing and relays. It also constitutes passage of the two diagonally split brake circuits.

- The pump motor drives an eccentric cam which in turn moves the plunger pump to generate hydraulic pressure.
- The housing accommodates the pump motor, solenoid valve and reservoir. It also constitutes a brake fluid passage.
- The plunger pump, when operated, draws the brake fluid from the reservoir, lets the fluid in a wheel cylinder drain into the reservoir, and/or forces the fluid into the master cylinder.
- The outlet solenoid valve is a 2-position type. It opens or closes the brake fluid passage between a wheel cylinder and the reservoir according to commands from the ABSCM.
- The inlet solenoid valve is duty-controlled to reduce brake fluid pulsation for minimum ABS operation noise.
- The reservoir temporarily stores the brake fluid drained from a wheel cylinder when pressure “decrease” control is performed.
- The valve relay controls power supply to the solenoid valves in response to a command from the ABSCM. In normal (IG ON) condition, the relay is closed to supply power to the solenoid valves. When an error occurs in the system, the valve relay is turned OFF to keep the fluid pressure circuit in the normal mode (non-ABS mode).
- The motor relay closes and supplies power to the pump motor in response to a command from the ABSCM during the ABS drive mode operations.
- The H/U has four operating modes; normal mode (non-ABS mode), and three ABS active modes, i.e., “increase”, “hold” and “decrease” modes.

ANTI-LOCK BRAKE SYSTEM (ABS)

ABS

1. DURING NORMAL BRAKING (ABS NOT ACTIVE)

Both the inlet and outlet solenoid valves are not energized.

This means that the inlet port of the inlet solenoid valve is open, whereas the outlet port of the outlet solenoid valve is closed. So the fluid pressure generated in the master cylinder is transmitted to the wheel cylinder, producing a brake force.

NOTE:

For simplicity of explanation, operation of the hydraulic control unit is represented by operation of a single wheel circuit.

ANTI-LOCK BRAKE SYSTEM (ABS)

ABS

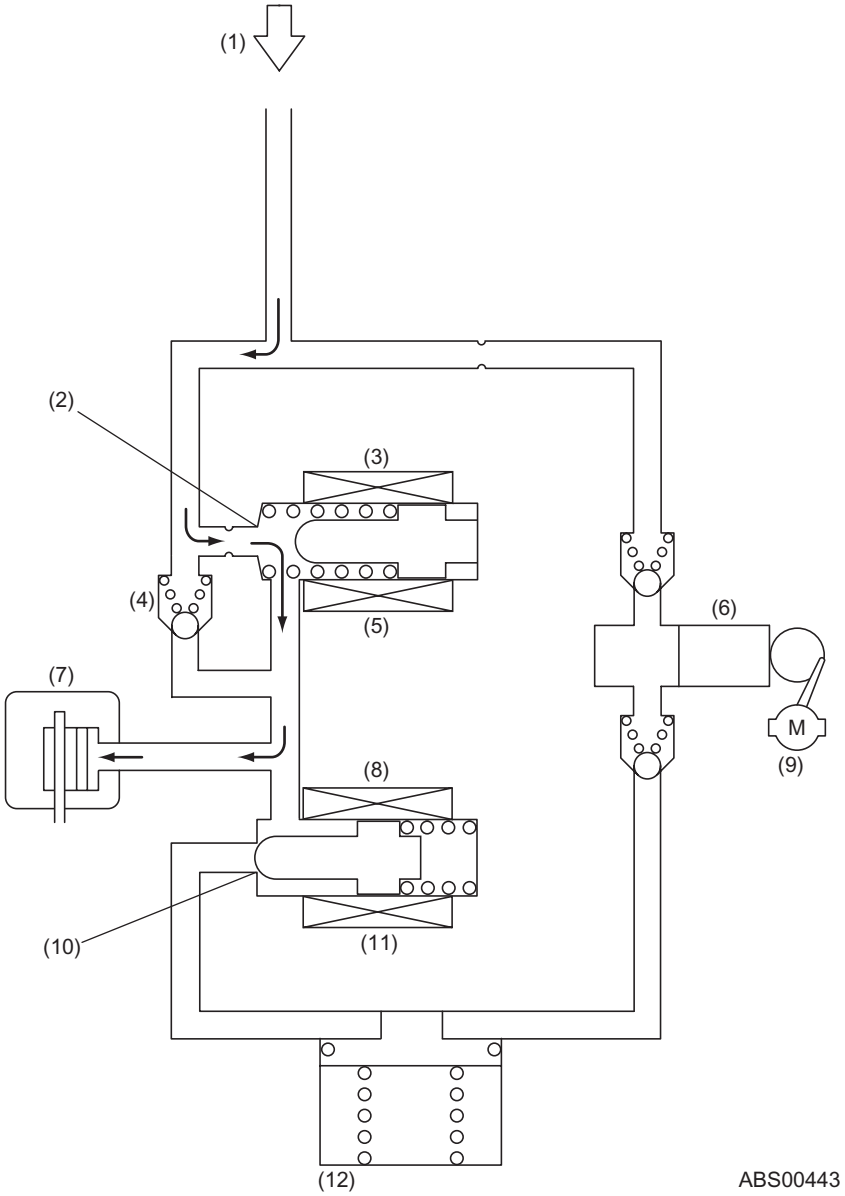

ABS00443

- | | |
|--------------------------|---------------------------|
| (1) From master cylinder | (7) Wheel cylinder |
| (2) Inlet port open | (8) Outlet solenoid valve |
| (3) Inlet solenoid valve | (9) Motor |
| (4) Check valve | (10) Outlet port closed |
| (5) Deenergized | (11) Deenergized |
| (6) Pump | (12) Reservoir |

ANTI-LOCK BRAKE SYSTEM (ABS)

ABS

2. PRESSURE “DECREASE” CONTROL (ABS ACTIVE)

Both the inlet and outlet solenoid valves are energized, which means that the inlet port is closed and the outlet port is open.

In this state, the wheel cylinder is isolated from the master cylinder but open to the reservoir, so the brake fluid in it can be drained into the reservoir, decreasing its pressure and reducing the braking force of the wheel.

The brake fluid collected in the reservoir is forced into the master cylinder by the pump.

During this phase of ABS operation, the pump motor continues operating.

NOTE:

For simplicity of explanation, operation of the H/U is represented by operation of a single wheel circuit.

ANTI-LOCK BRAKE SYSTEM (ABS)

ABS

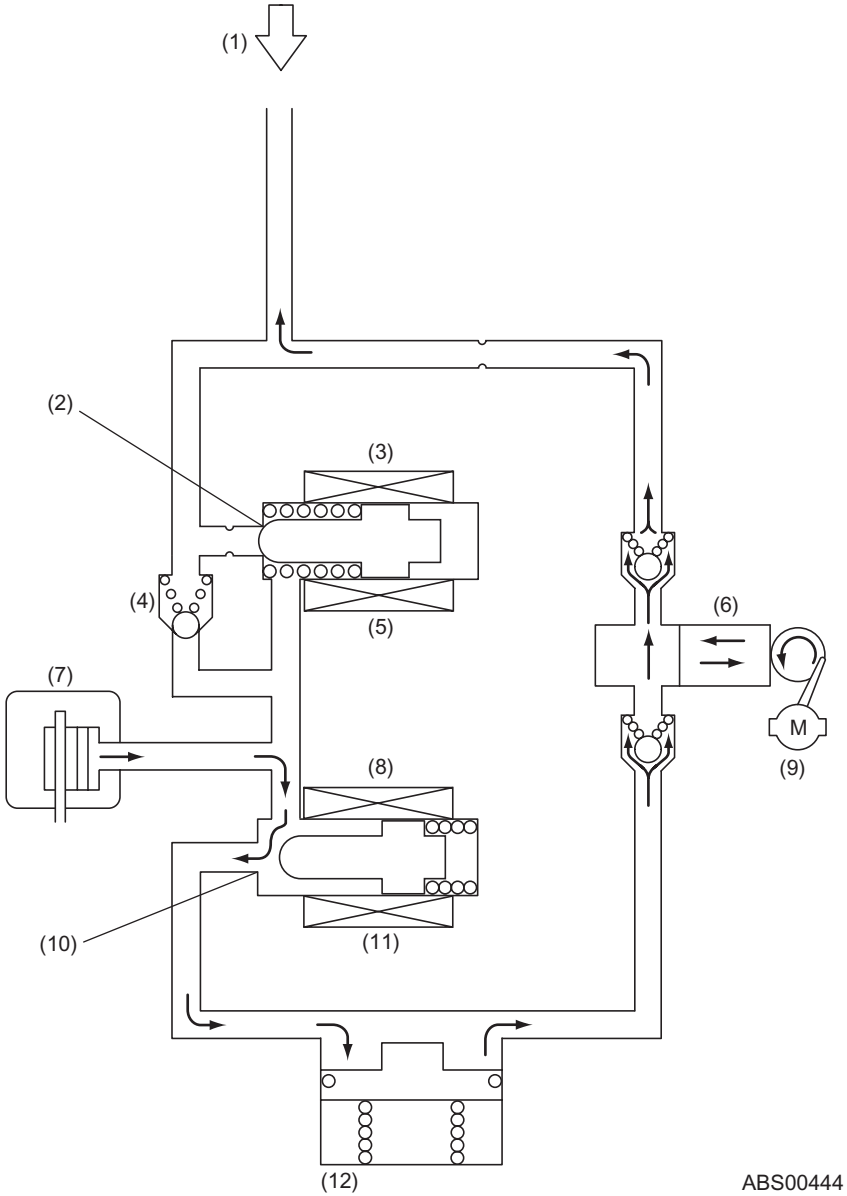

ABS00444

- | | |
|--------------------------|---------------------------|
| (1) From master cylinder | (7) Wheel cylinder |
| (2) Inlet port closed | (8) Outlet solenoid valve |
| (3) Inlet solenoid valve | (9) Motor |
| (4) Check valve | (10) Outlet port open |
| (5) Energized | (11) Energized |
| (6) Pump | (12) Reservoir |

ANTI-LOCK BRAKE SYSTEM (ABS)

ABS

3. PRESSURE “HOLD” CONTROL (ABS ACTIVE)

The inlet solenoid valve is energized, so the inlet port is closed.

On the other hand, the outlet solenoid valve is de-energized, so the output port is also closed. In this state, all the passages connecting the wheel cylinder, master cylinder and reservoir are blocked. As a result, the fluid pressure in the wheel cylinder is held unchanged.

During this phase of ABS operation, the pump motor continues operating.

NOTE:

For simplicity of explanation, operation of the H/U is represented by operation of a single wheel circuit.

ANTI-LOCK BRAKE SYSTEM (ABS)

ABS

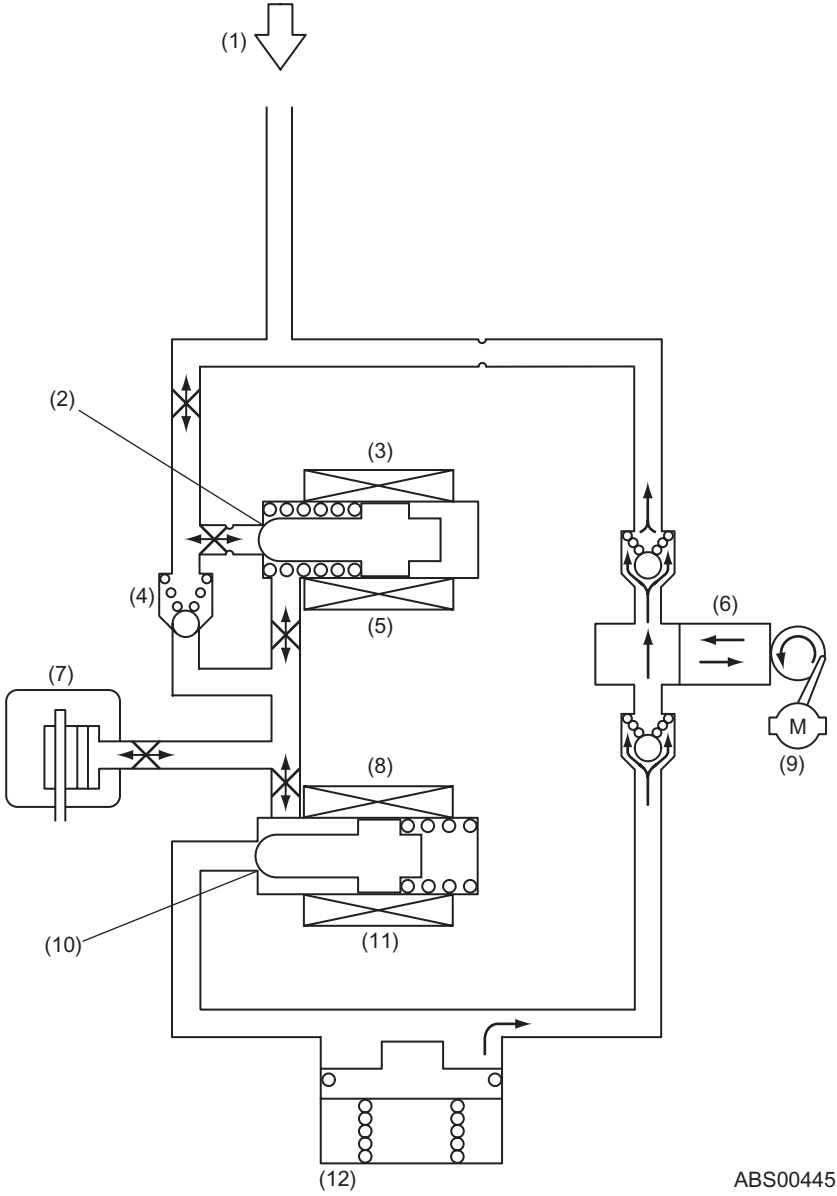

ABS00445

- | | |
|--------------------------|---------------------------|
| (1) From master cylinder | (7) Wheel cylinder |
| (2) Inlet port closed | (8) Outlet solenoid valve |
| (3) Inlet solenoid valve | (9) Motor |
| (4) Check valve | (10) Outlet port closed |
| (5) Energized | (11) Deenergized |
| (6) Pump | (12) Reservoir |

ANTI-LOCK BRAKE SYSTEM (ABS)

ABS

4. PRESSURE “INCREASE” CONTROL (ABS ACTIVE)

Both the inlet and outlet solenoid valves are de-energized, which means that the inlet port of the inlet solenoid valve is open, whereas the outlet port of the outlet solenoid valve is closed. So the fluid pressure generated in the master cylinder is transmitted to the wheel cylinder and increased fluid pressure in the wheel cylinder applies the brake with a larger force.

During this phase of ABS operation, the pump motor continues operating.

NOTE:

For simplicity of explanation, operation of the H/U is represented by operation of a single wheel circuit.

ANTI-LOCK BRAKE SYSTEM (ABS)

ABS

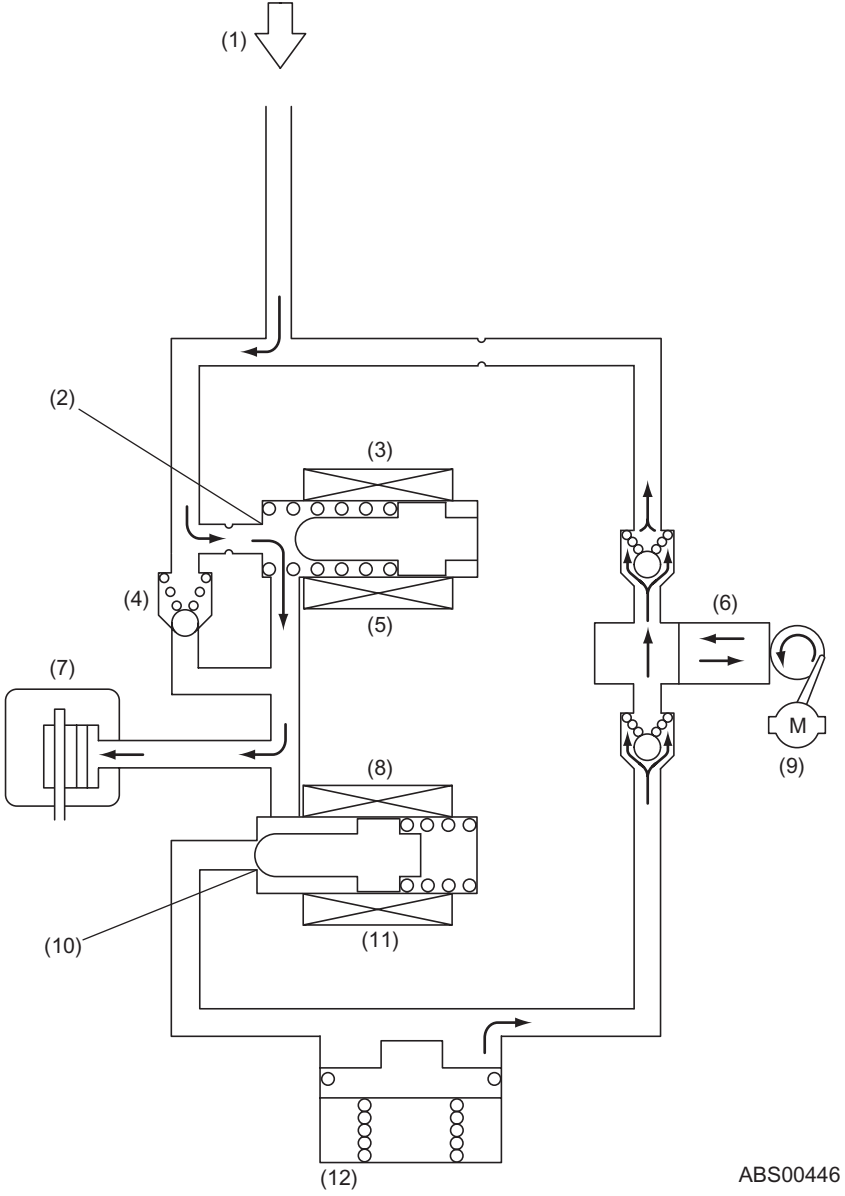

ABS00446

- | | |
|--------------------------|---------------------------|
| (1) From master cylinder | (7) Wheel cylinder |
| (2) Inlet port open | (8) Outlet solenoid valve |
| (3) Inlet solenoid valve | (9) Motor |
| (4) Check valve | (10) Outlet port closed |
| (5) Deenergized | (11) Deenergized |
| (6) Pump | (12) Reservoir |

G: ABS CONTROL CYCLE CURVES

Depressing the brake pedal increases the brake fluid pressure in each wheel cylinder, which in turn decreases the wheel speed (or increases the wheel deceleration rate). When the brake fluid pressure is increased to a level of point "A" of the brake fluid pressure curve in the diagram (at which the wheel deceleration rate exceeds threshold " $-b_0$ "), the ABSCM makes a pressure "hold" control. At the same time, the ABSCM calculates a "dummy" vehicle speed which is a reference speed it uses in the next stage of control.

When the wheel speed then drops below the slip ratio setting, i.e., a speed lower than the "dummy" vehicle speed by the predetermined value (at point "B" of the pressure curve), the ABSCM makes a control to prevent the wheel from locking, or a pressure "decrease" control.

As the wheel cylinder pressure decreases, the wheel speed starts increasing (or the wheel acceleration rate starts rising). When the wheel acceleration rate exceeds threshold " $+b_{10}$ " (at point "C" of the pressure curve), the ABSCM makes a pressure "hold" control. When the wheel acceleration rate exceeds threshold " $+b_{20}$ " (at point "D" of the pressure curve), the ABSCM recognizes that wheel lock-up will not occur and then makes a pressure "increase" control.

When the wheel acceleration rate drops below threshold " $+b_{20}$ ", (at point "E" of the pressure curve), the ABSCM starts pressure "hold" and "increase" control cycles at a given interval.

When the wheel deceleration rate then exceeds threshold " $-b_0$ " (at point "F" of the pressure curve), the ABSCM immediately makes a pressure "decrease" control.

ANTI-LOCK BRAKE SYSTEM (ABS)

ABS

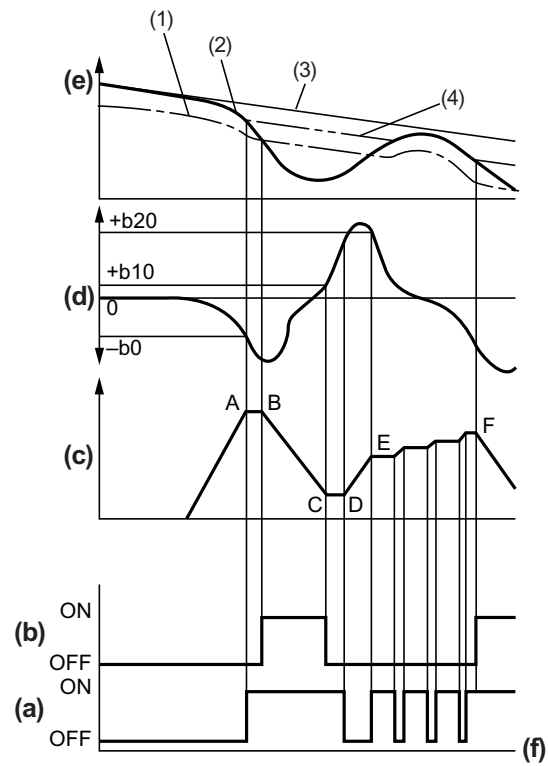

ABS00033

- | | |
|--|--|
| <p>(a) Inlet solenoid valve</p> <p>(b) Outlet solenoid valve</p> <p>(c) Brake fluid pressure</p> <p>(d) Wheel acceleration/deceleration</p> <p>(e) Speed</p> <p>(f) Time</p> | <p>(1) Slip ratio setting</p> <p>(2) Wheel speed</p> <p>(3) Vehicle speed</p> <p>(4) Dummy vehicle speed</p> |
|--|--|

Brake fluid pressure	Inlet solenoid valve	Outlet solenoid valve
Increase	OFF	OFF
Hold	ON	OFF
Decrease	ON	ON

ANTI-LOCK BRAKE SYSTEM (ABS)

ABS

H: ABS WARNING LIGHT AND BRAKE WARNING LIGHT (ALSO FUNCTIONS AS EBD WARNING LIGHT)

When a fault occurs in the signal transmission system or the ABSCM, the ABS warning light and brake warning light in the combination meter come on. At the same time, the current to the hydraulic control unit is interrupted. The brake system then functions in the same manner as a system without ABS.

If the warning light comes on, one or more diagnostic trouble codes should be stored in the ABSCM. To identify these codes, use a Subaru select monitor.

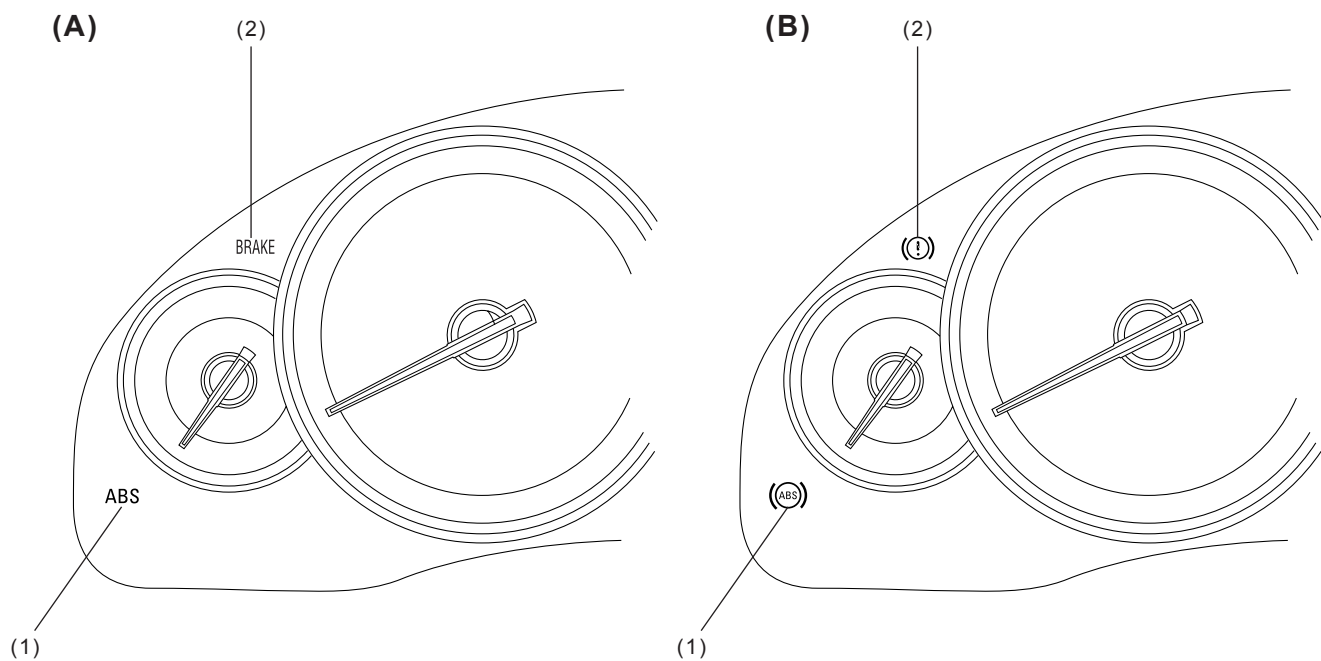

ABS00577

- (A) U.S. spec. vehicle
- (B) Canada spec. vehicle
- (1) ABS warning light
- (2) Brake warning light (also functions as EBD warning light)

ANTI-LOCK BRAKE SYSTEM (ABS)

ABS

I: G SENSOR

The G sensor detects changes in the vehicle's acceleration/deceleration rate in the longitudinal direction.

A piezo-resistor is formed on the beam. When the mass area moves during acceleration and deceleration, the beam distorts causing the resistance of the piezo-resistor to change. This change is converted into change in voltage and sent to the ABSCM.

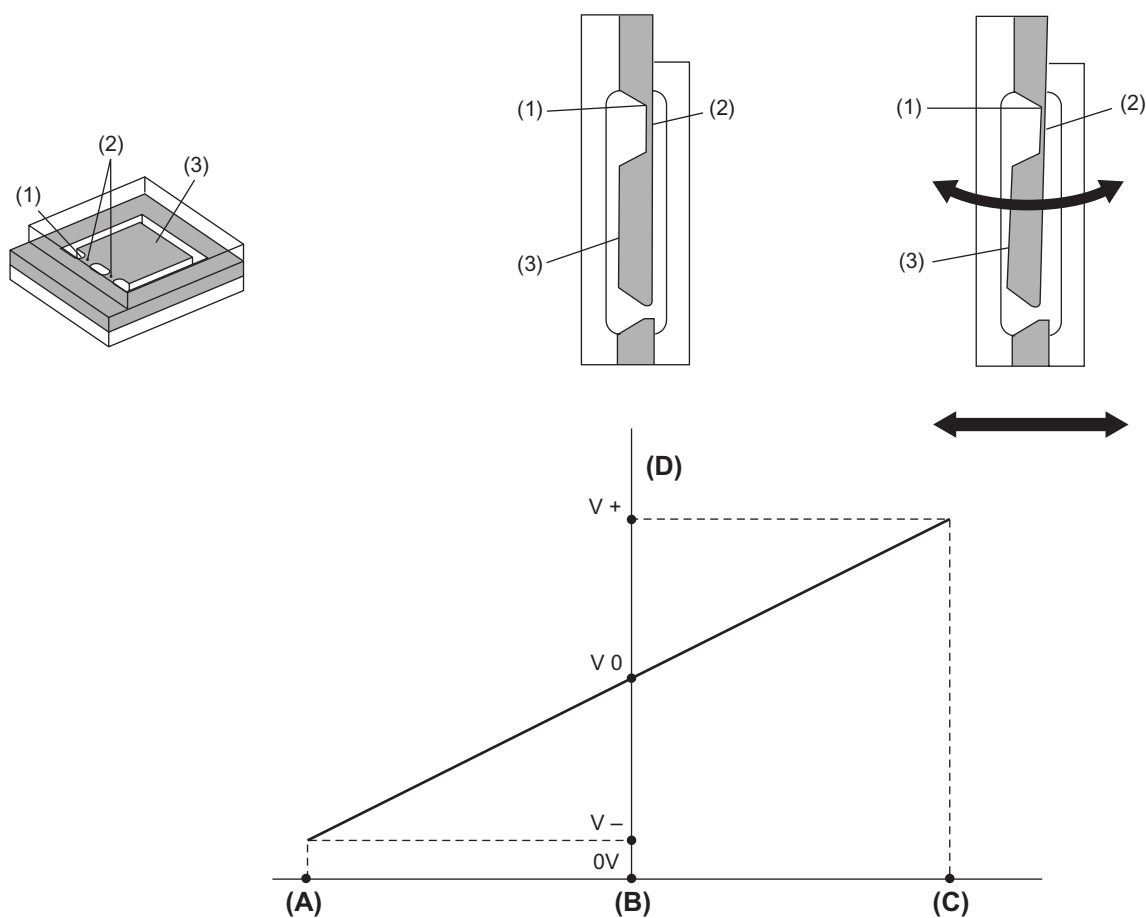

ABS00322

- | | | |
|-----------------------------|--------------------|------------------|
| (1) Beam | (2) Piezo-resistor | (3) Mass area |
| (A) Accelerating | (B) Cruising | (C) Decelerating |
| (D) G sensor output voltage | | |