

EXTERIOR BODY PANELS

FRONT HOOD

EXTERIOR BODY PANELS

1. Front Hood

An aluminum hood is used on all models to reduce weight.

REAR GATE PANEL

EXTERIOR BODY PANELS

2. Rear Gate Panel

An aluminum rear gate panel is used on all models.

By changing the material to aluminum, the weight is reduced and the opening and closing of the rear gate is facilitated.

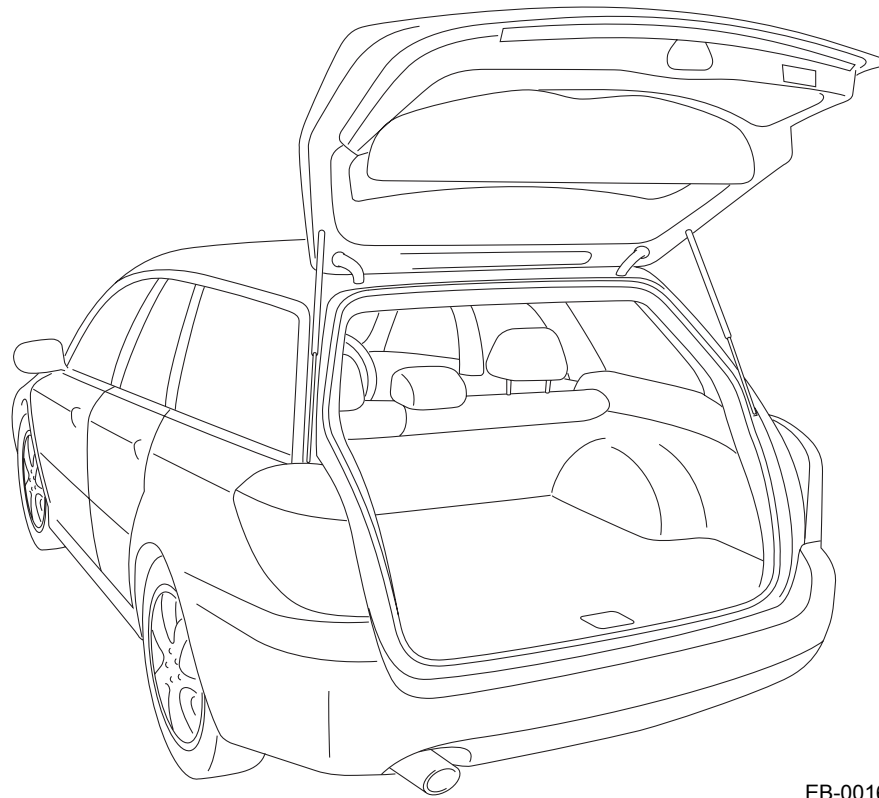

EB-00166

TRUNK LID

EXTERIOR BODY PANELS

3. Trunk Lid

A: TRUNK LID ARM

By minimizing the size of the trunk lid arm, the traveling radius of the arm is made smaller to acquire a wider cargo space.

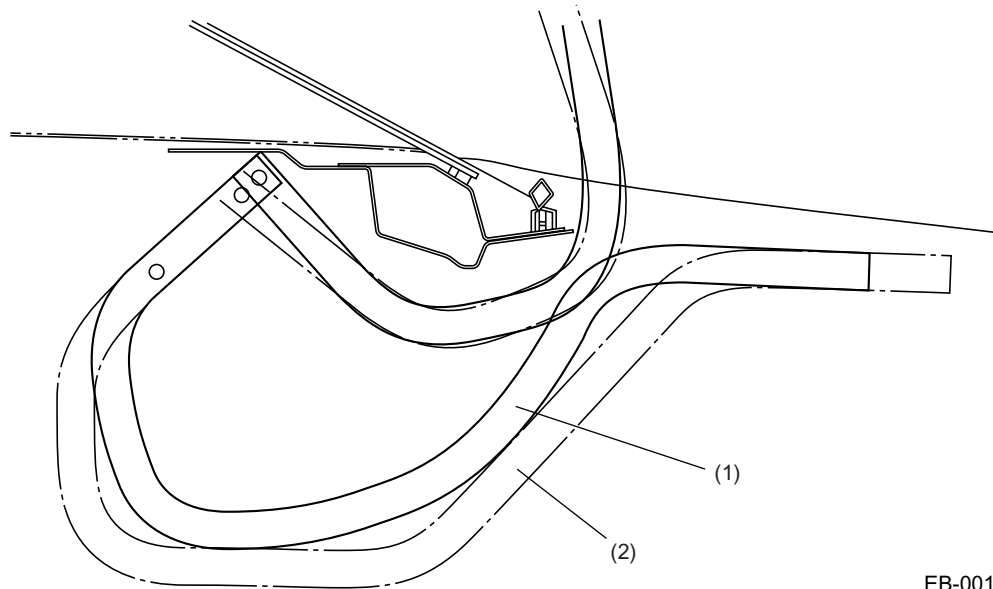

EB-00167

(1) New type

(2) Former type

The trunk lid arm is stored inside the trunk trim when the trunk lid is closed. This prevents the luggage from interfering with the arm when closing the trunk.

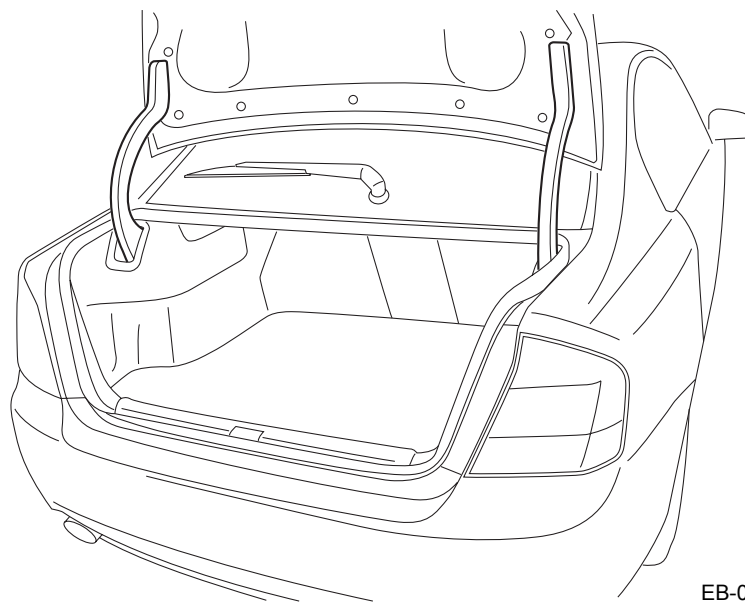

EB-00168

FRONT FENDER PANEL

EXTERIOR BODY PANELS

4. Front Fender Panel

By providing a clearance (A) between the wheel apron upper area and the fender upper area, the impact absorbing capacity and pedestrian protection is enhanced.

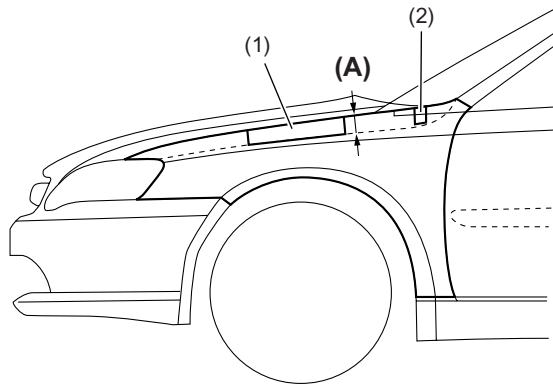

(1) Fender extension, front

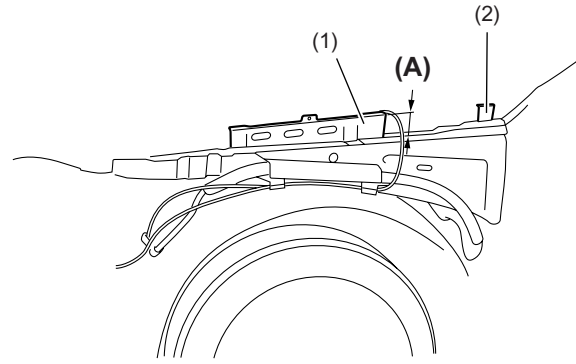

(2) Fender extension, rear

EB-00172

DOOR

EXTERIOR BODY PANELS

5. Door

A: DOOR CONSTRUCTION

- The front and rear doors have in their inside a side door beam and a window shoulder area reinforcement.

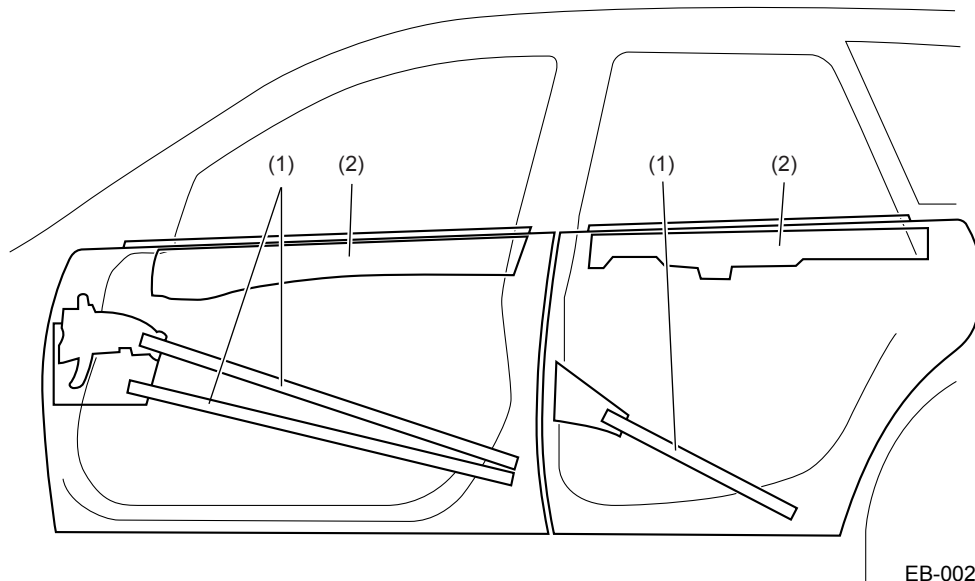

EB-00229

(1) Side door beam

(2) Window shoulder area reinforcement

DOOR

EXTERIOR BODY PANELS

- Tight closure of each door is ensured by the double weather strip at the bottom which also reduces intruding noise.

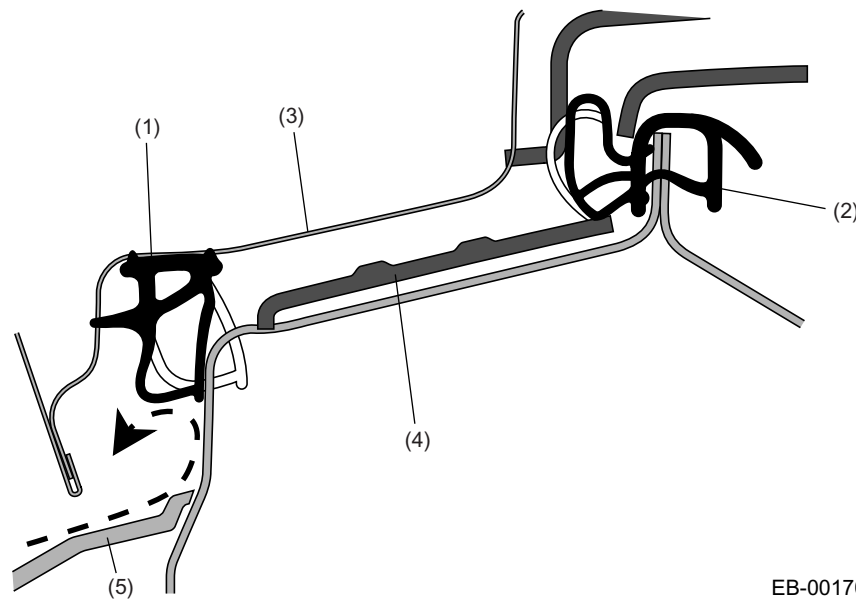

EB-00170

- | | |
|-------------------------|-----------------------|
| (1) Outer weather strip | (4) Scuff plate |
| (2) Inner weather strip | (5) Side sill spoiler |
| (3) Door panel | |

B: REAR DOOR CATCHER

This prevents the rear door from deflecting into the cabin in case of a side collision.

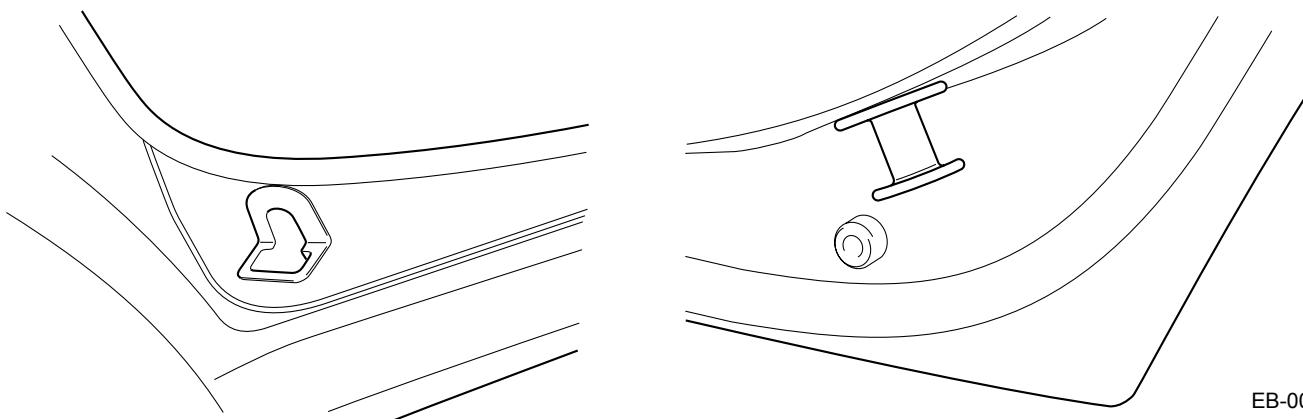

EB-00171