

INTAKE (INDUCTION) (H4DOTC)

INTAKE SYSTEM

INTAKE (INDUCTION)

1. Intake System

A: GENERAL

The intake system consists of an intake duct, a resonator integrated with the air cleaner case, and an air cleaner element housed in the air cleaner case. The resonator, located upstream of the air cleaner case, effectively reduces the intake noise level.

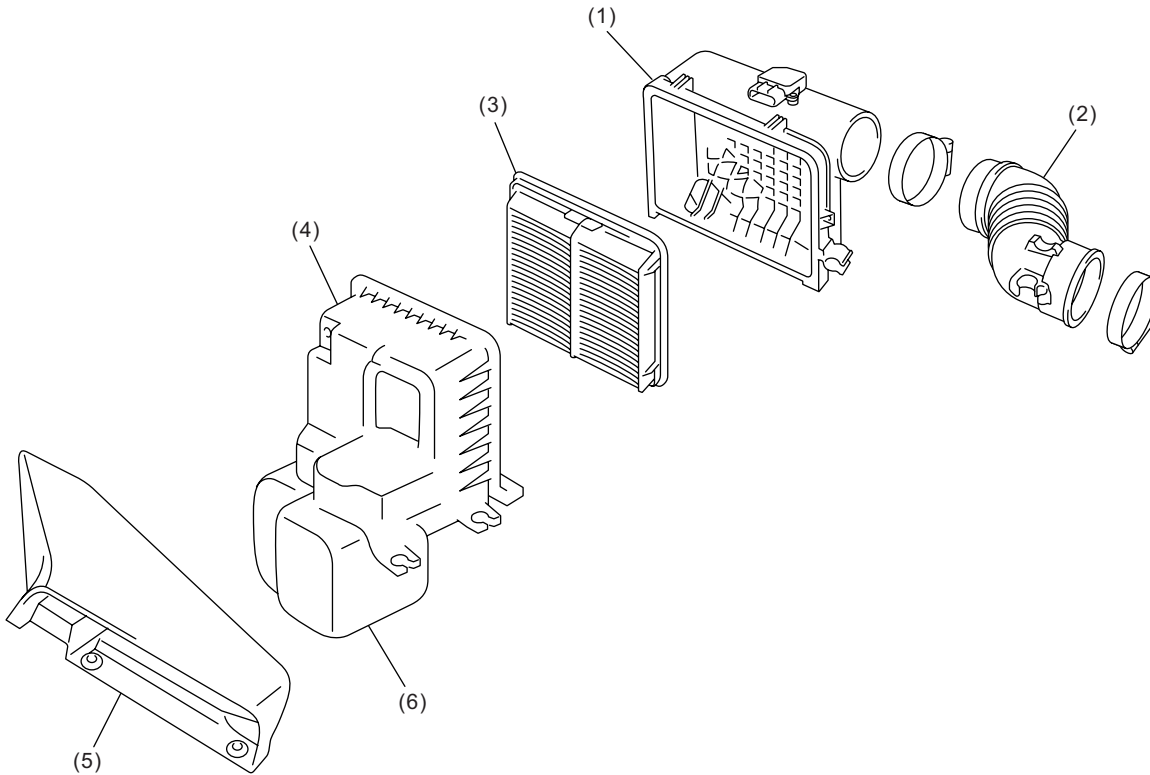

IN-02098

- (1) Air cleaner rear case
- (2) Air intake boot
- (3) Air cleaner element

- (4) Air cleaner front case
- (5) Air intake duct
- (6) Resonator chamber

2. Turbocharger System

A: GENERAL

- The turbocharger system consists of a water-cooled turbocharger, air-cooled intercooler, wastegate control solenoid valve, etc.
- The turbine rotated by exhaust gas pressure rotates the compressor.
- As a result, the intake air is compressed by the compressor before it is delivered to the intake manifold.
- This turbocharger system controls the supercharging pressure according to changes in the atmospheric pressure. Even at a high altitude, therefore, the system offers stable performance without being affected by variations in atmospheric pressure.

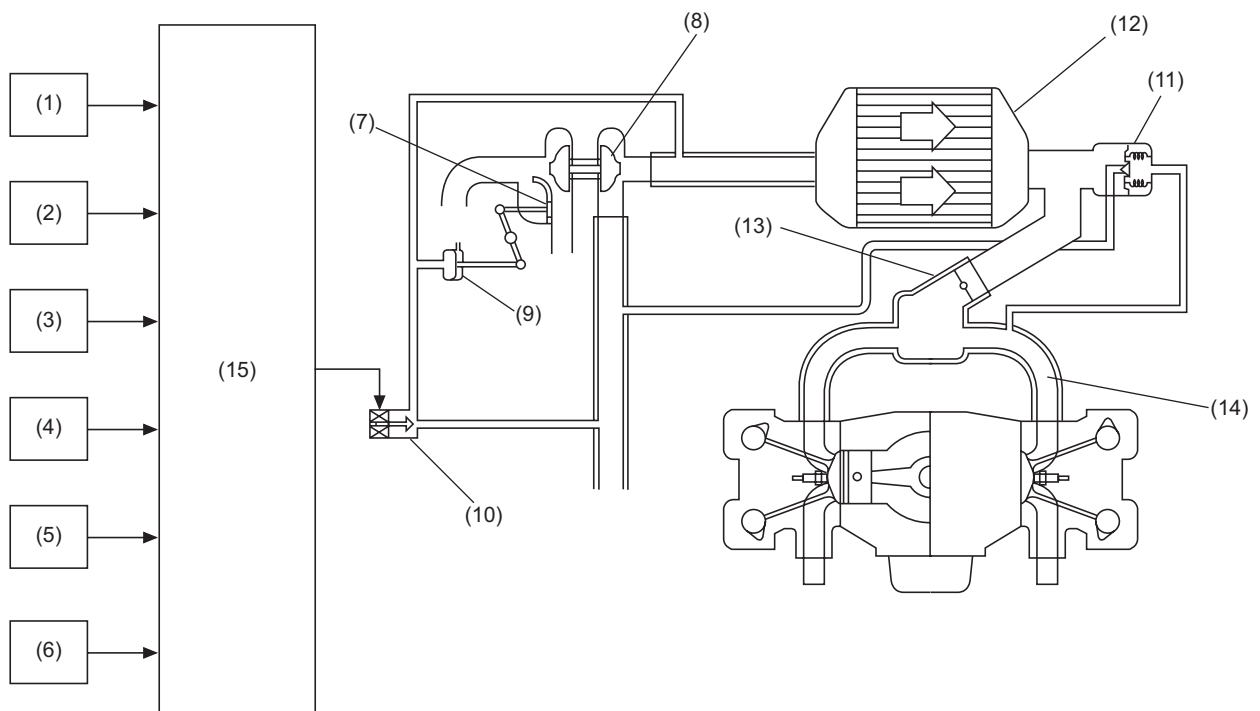

IN-00234

- | | |
|---|--|
| (1) Manifold absolute pressure sensor | (9) Wastegate controller |
| (2) Crankshaft position sensor | (10) Wastegate control solenoid valve |
| (3) Camshaft position sensor | (11) Air bypass valve |
| (4) Throttle position sensor | (12) Intercooler |
| (5) Engine coolant temperature sensor | (13) Throttle body |
| (6) Mass air flow and intake air temperature sensor | (14) Intake manifold |
| (7) Wastegate valve | (15) ECM (with built-in atmospheric pressure sensor) |
| (8) Turbocharger unit | |

TURBOCHARGER SYSTEM

INTAKE (INDUCTION)

B: TURBOCHARGER UNIT

The turbocharger is water-cooled. It utilizes a wastegate valve to adjust its supercharging pressure to an optimum level. The turbine is housed in a lightweight, thin-wall, heat-resistant casting. The compressor housing is made of thin-wall, aluminum alloy casting. The shaft for turbine and compressor is supported by a full-floating metal bearing system.

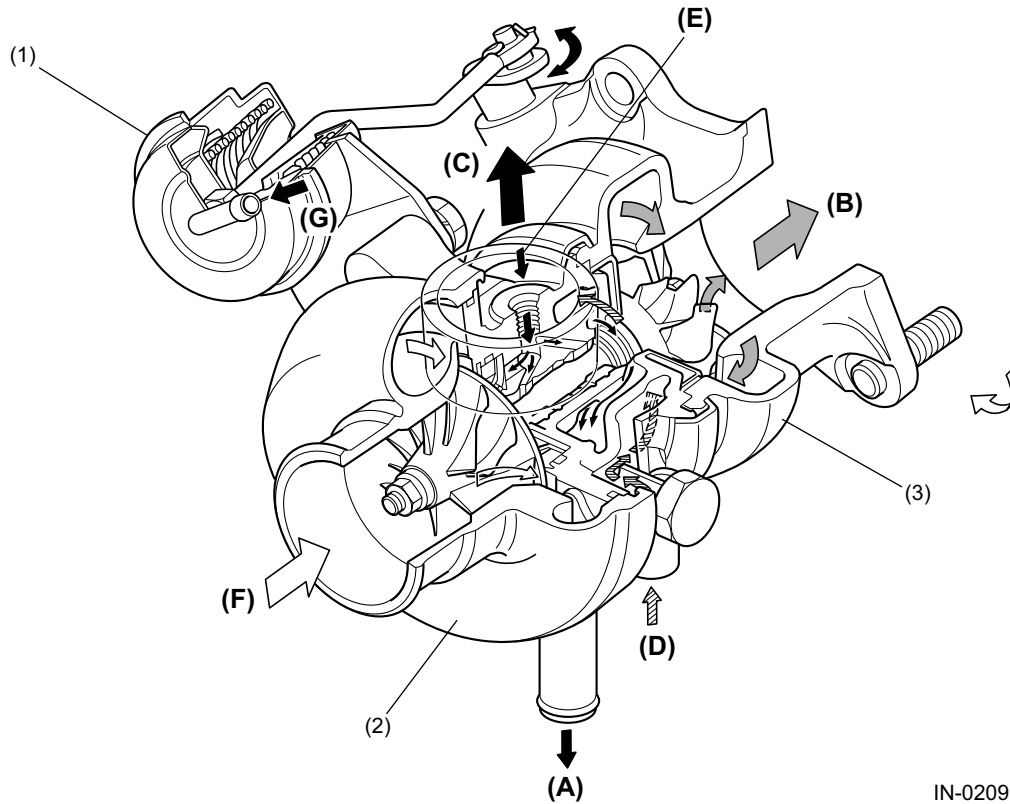

IN-02099

- (1) Wastegate controller
- (2) Compressor housing
- (3) Turbine housing

- (A) Lubricating oil outlet
- (B) Exhaust gas outlet
- (C) Air outlet port
- (D) Coolant inlet

- (E) Lubricating oil inlet
- (F) Air inlet
- (G) Wastegate valve operation pressure

C: LUBRICATION OF TURBOCHARGER

The turbocharger is lubricated by engine oil branched out from the oil pump. To cope with very high speed of the turbocharger turbine and the compressor shaft which may reach a maximum of several hundred thousands of rpm, full-floating type bearings are used which can form adequate oil films on their inside and outside during running.

Further the oil supplied to the turbocharger also plays a role of cooling the turbine so that heat from exhaust gas does not transmitted to the bearings.

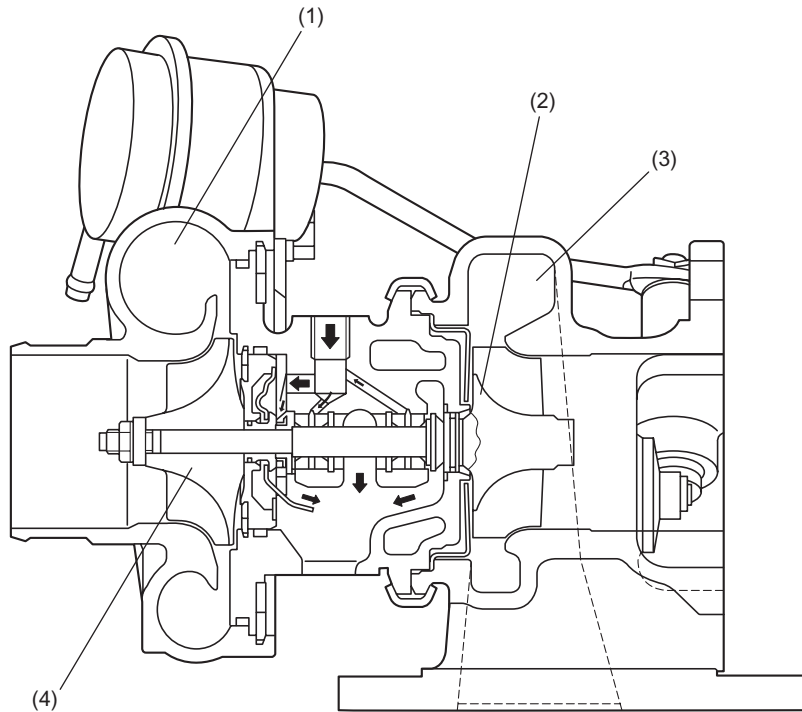

IN-00048

(1) Compressor housing

(2) Turbine wheel

(3) Turbine housing

(4) Compressor impeller

D: COOLING OF TURBOCHARGER

The turbocharger unit is cooled by engine coolant, which enhances the reliability and durability of the unit. The engine coolant from the coolant drain hose located under the cylinder head is led by a pipe to the coolant passage provided in the turbocharger bearing housing. After cooling the bearing housing, the engine coolant is led into the coolant filler tank through a pipe.

TURBOCHARGER SYSTEM

INTAKE (INDUCTION)

E: WASTEGATE CONTROL SOLENOID VALVE

The wastegate control solenoid valve switches the intake air pressure passages to the wastegate controller in response to signals from the ECM. When the solenoid valve opens, the intake air pressure upstream of the turbocharger unit is applied to the wastegate controller. When the solenoid valve closes, the intake air pressure downstream of the turbocharger unit (supercharged air pressure) is applied to the wastegate controller.

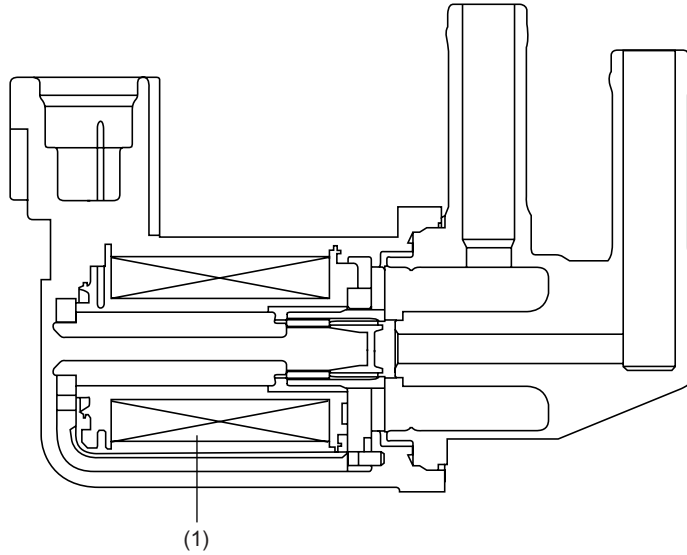

IN-02001

(1) Coil

TURBOCHARGER SYSTEM

INTAKE (INDUCTION)

F: REGULATION OF SUPERCHARGING PRESSURE

1. BASIC FUNCTION OF THE WASTEGATE VALVE

When the engine speed increases as the throttle valve opens, the amount of exhaust gas increases. This increases the speed of the turbine (approx. 20,000 to 150,000 rpm), the supercharging pressure and the engine output.

If the resultant supercharging pressure is extremely high, however, it may cause knocking and an excessively high thermal load on such engine components as pistons. In the worst case, the engine may be damaged or broken. To prevent this, the waste gate valve and its controller are provided. By sensing the supercharging pressure, the waste gate valve controller controls the operation of the waste gate valve to maintain the supercharging pressure at a predetermined level.

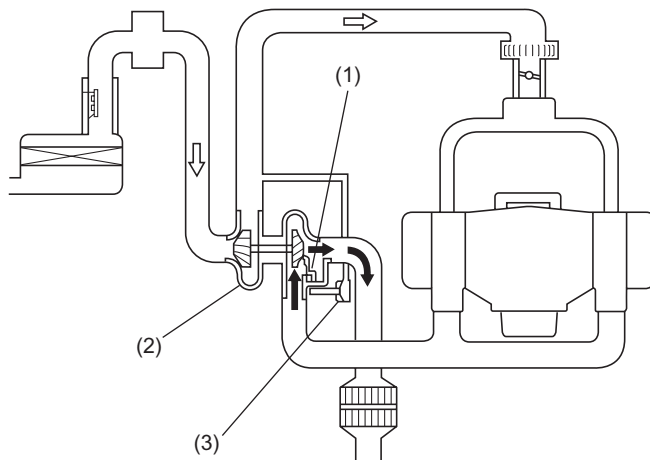

IN-00049

- (1) Wastegate valve
- (2) Turbocharger
- (3) Wastegate valve controller

TURBOCHARGER SYSTEM

INTAKE (INDUCTION)

While the supercharging pressure is lower than the predetermined level, the wastegate valve is closed so that entire exhaust gas is directed to the turbine.

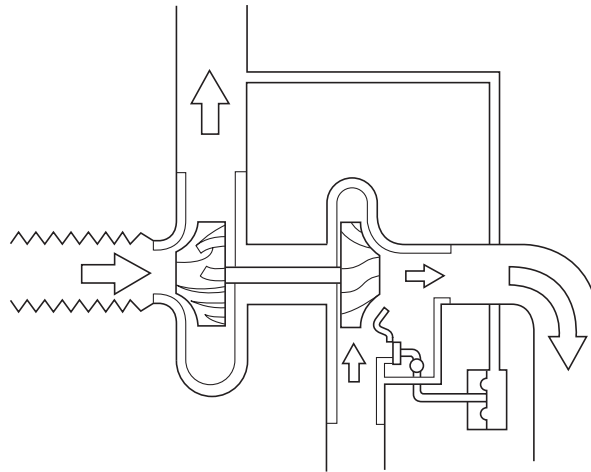

IN-00050

When the supercharging pressure reaches the predetermined level, the wastegate controller lets the supercharging pressure press the diaphragm. This causes the wastegate valve to open through a linkage. With the wastegate valve open, part of the exhaust gas is allowed to flow into the exhaust gas pipe that bypasses the passage to the turbine.

This decreases the exhaust gas pressure that rotates the turbine and keeps the supercharging pressure constant.

- It means $P_2 - P_1 = \text{constant}$.

P_1 : Atmospheric pressure

P_2 : Supercharging pressure

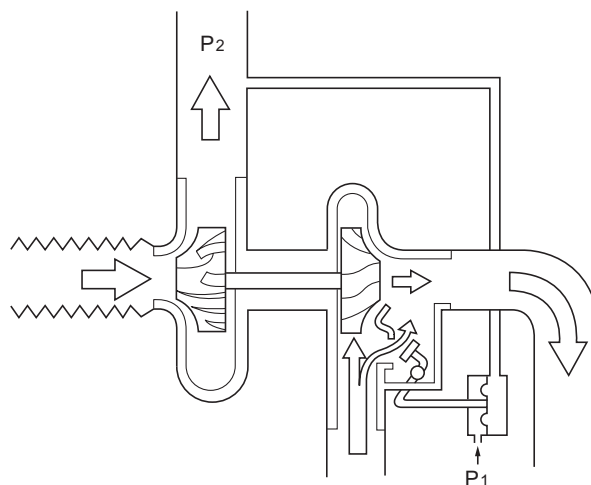

IN-00051

TURBOCHARGER SYSTEM

INTAKE (INDUCTION)

2. CONCEPT OF THE WASTEGATE VALVE CONTROL

At high altitudes, the atmospheric pressure (P_1) is low, so that the supercharging pressure (P_2) is also low in a conventional system. The wastegate solenoid valve operates in such a way that a constant supercharging pressure (P_2) is maintained by acting in response to change in the atmospheric pressure.

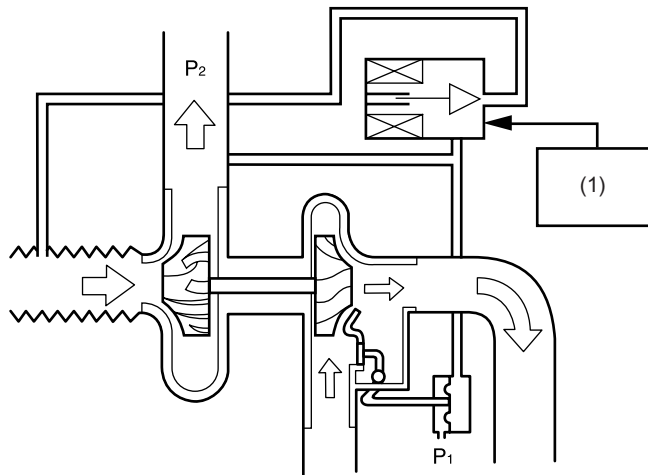

IN-02002

(1) ECU

G: INTERCOOLER

- Since the intake air having passed through the turbocharger unit is heated to a very high temperature, the air itself expands, resulting in a lower supercharging efficiency. The intercooler is provided just before the throttle body to cool down the intake air and improve the boosting efficiency.
- The intercooler is an air cooled type. The air delivered from the air intake duct provided at the engine hood flows through the core and cools the intake air passing through the intercooler.

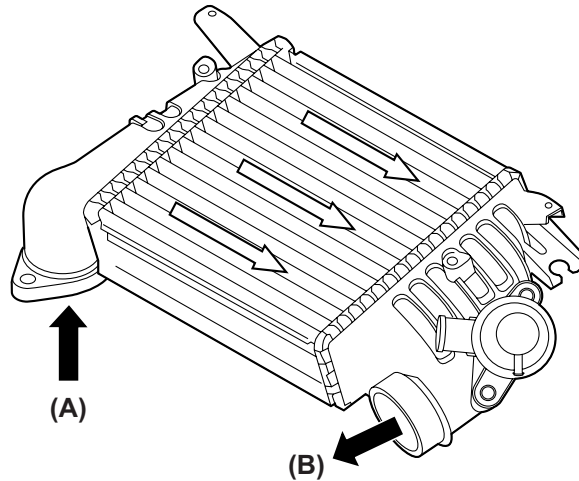

IN-02100

- (A) From turbocharger
- (B) To throttle body

TURBOCHARGER SYSTEM

INTAKE (INDUCTION)

H: AIR BYPASS VALVE

When a throttle valve is suddenly closed, a surge may occur due to a sudden rise of the air pressure in the passage between the turbocharger and throttle body. To prevent this, an air bypass valve and air passage are provided. The air bypass valve, actuated by the vacuum created by a sudden closure of the throttle valve, allows the suction air to bypass the turbocharger and flow directly upstream, thus lowering the pressure in the air passage.

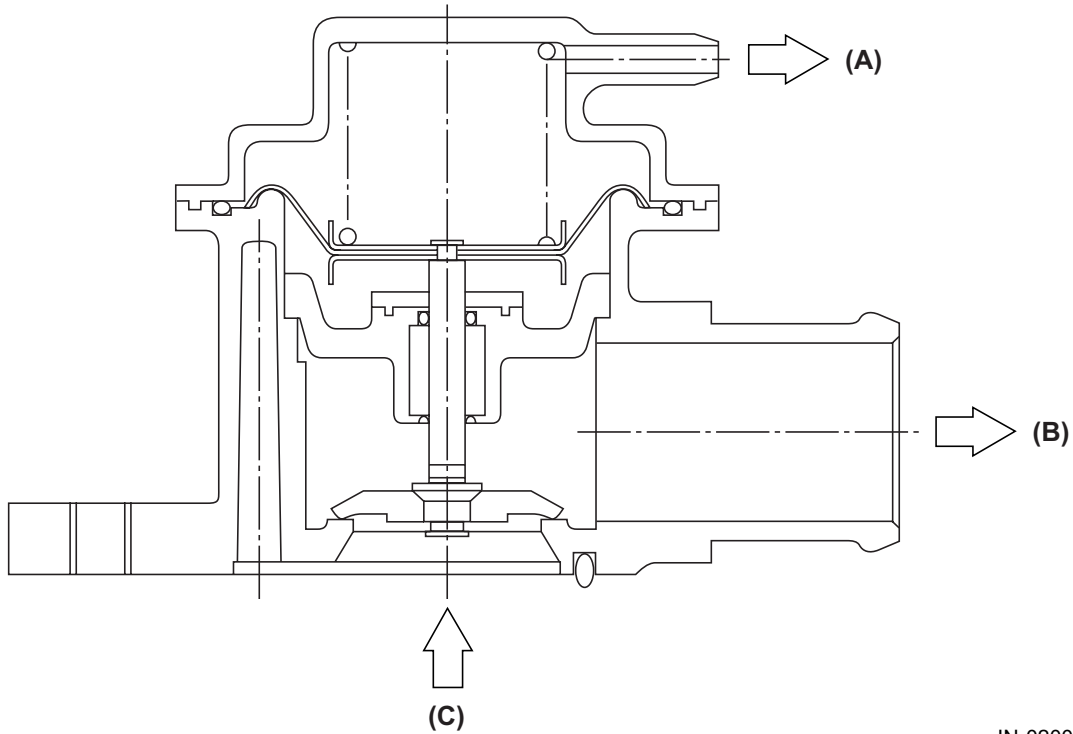

IN-02003

- (A) To intake manifold
- (B) To turbocharger inlet duct
- (C) From intercooler