

**SUNROOF T-TOP
CONVERTIBLE TOP
(SUNROOF)**

SUNROOF

SUNROOF/T-TOP/CONVERTIBLE TOP

1. Sunroof

A: SEDAN MODELS

1. DESCRIPTION

The sunroof operates on an automatic opening/closing system including tilt and slide mechanisms.

- A motor with a built-in microprocessor is used for the sunroof motor, which provides one-touch automatic opening and closing functions with a jamming prevention feature. (The system operates in auto mode when the switch is pushed for more than 0.3 seconds.)
- Reduced thickness of the sunroof provides extra overhead clearance in the passenger compartment.
- The frame, glass lid and mechanism parts are refined to reduce considerable amount of weight.

2. FUNCTION

● Sunroof tilting and sliding operation

- With the glass lid fully closed, pushing the rear side of the tilt switch causes the rear end of the glass lid to rise by 30 mm (1.18 in). Pushing then the front side of the switch causes the lid to lower to the original position.

- Pushing the OPEN/CLOSE switch rearward causes the glass lid to slide rearward and open. Pushing the switch forward causes the glass lid to move forward and stop at a point 150 mm (5.91 in) before the fully closed position. Pushing the switch again closes the lid completely.

● Sunshade operation

- The sunshade can be opened or closed manually when the glass lid is closed.
- The sunshade moves rearward together with the glass lid when the OPEN side of the OPEN/CLOSE switch is pushed. (When closed, only the glass lid moves.)

SUNROOF

SUNROOF/T-TOP/CONVERTIBLE TOP

B: WAGON MODELS

1. DESCRIPTION

The sunroof operates on an automatic opening/closing system, and the joined opening area consists of a tilting front glass lid and a sliding rear glass lid.

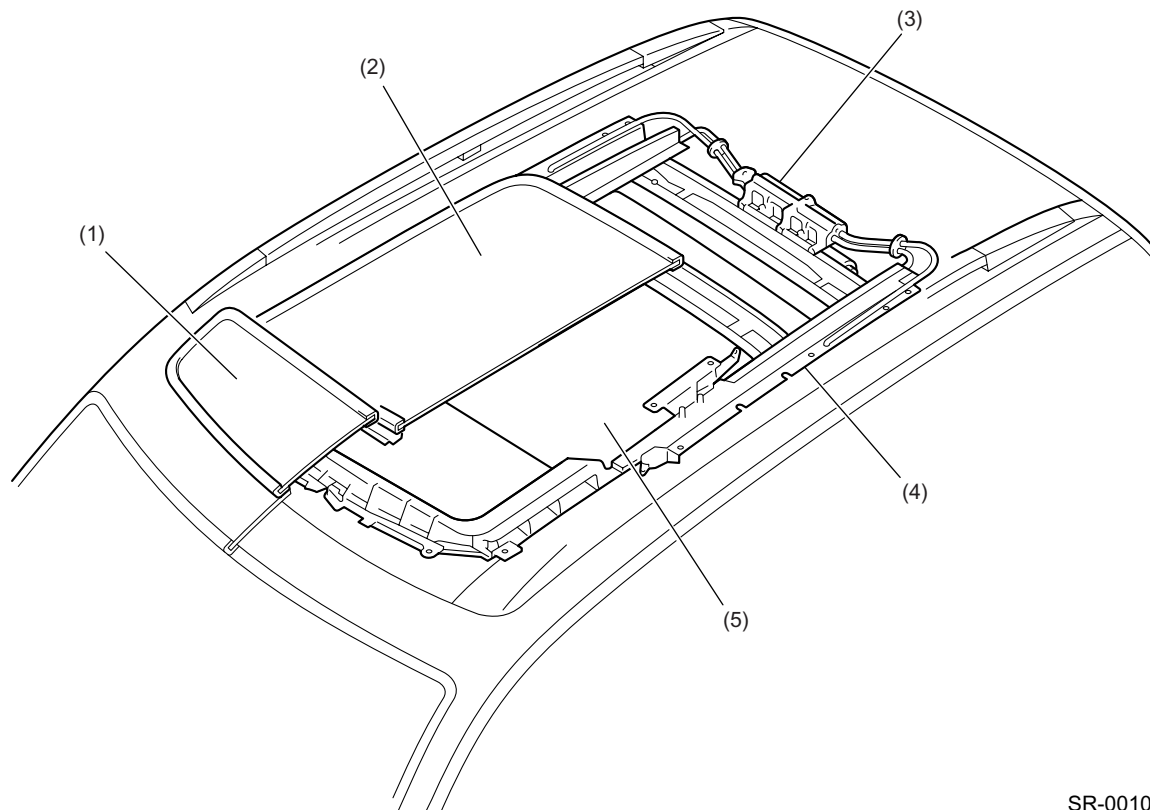

SR-00105

- (1) Front glass lid
- (2) Rear glass lid
- (3) Motor
- (4) Frame
- (5) Sunshade

- The sunroof openings are joined to form a single, wide opening (720 mm (28.35 in) long and 600 mm (23.62 in) wide), aiming to improve the “open and free” feeling to a great extent.
- A motor with a built-in microprocessor is used for the sunroof motor, which provides one-touch automatic opening and closing functions with a jamming prevention feature. (The system operates in auto mode when the switch is pushed.)
- The frame, glass lid and mechanism parts are refined to reduce considerable amount of weight.
- The contour and tilt-up angle of the front glass lid are refined to enhance the effect as a deflector and reduce the wind blowing into the cabin when the sunroof is open. Also, the edge shape of the front glass lid is optimized to minimize unpleasant wind shearing noise.

SUNROOF

SUNROOF/T-TOP/CONVERTIBLE TOP

2. FUNCTION

● **Open and close operations**

- When the switch is pushed rearwards, the rear edge of the front glass lid tilts up by 45 mm (1.77 in).
- When the switch is pushed forwards, the front glass lid tilts down to the fully closed position and then stops.
- When the sunroof switch is pushed rearwards while the front glass lid is fully closed, the rear end of the front glass lid stops at a position ready for tilting up. When the switch is pushed again, the rear end of the front glass lid further tilts up to a position of 70 mm (2.76 in), and the rear glass lid slides and opens to a position 410 mm (16.14 in) from the rear end of the front glass lid and stops. When the sunroof switch is pushed again, the rear glass lid opens to the wide-open position [550 mm (21.65 in) from the front glass lid rear end].
- When the sunroof switch is pushed forwards while the rear glass lid is at its wide-open position, the rear glass lid moves forward, and then comes to a stop when its front end reaches a position 150 mm (5.91 in) from the rear end of the front glass lid. When the sunroof switch is pushed again, the rear glass lid moves to the fully closed position, and the front glass lid closes until it reaches its tilted up position. When the sunroof switch is pushed once more, the front glass lid tilts down to the fully closed position.

● **Sunshade operation**

- When the front glass lid tilts up, the shade opens at its front edge by 20 mm (0.79 in) in connection with the lid, to improve ventilation. However, when tilting down the shade will not move in connection with the front glass lid so the shade must be manually closed.
- The sunshade automatically opens or closes together with the rear glass lid. However, when completely closing the sunroof, the sunshade will come to a stop at a position 170 mm (6.69 in) before the fully closed position even when the front glass lid is completely tilted down. Close the shade manually after the glass lid is completely closed.